

SIGN POST AND STUB POST BASE CONNECTION DETAIL ELEVATION VIEW

(FOR SQUARE TUBE SUPPORT POSTS)

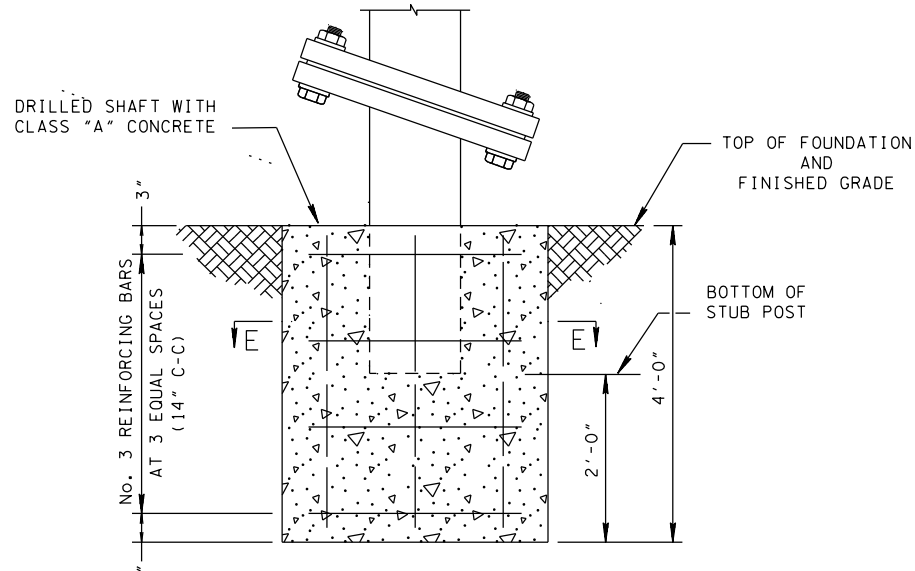

FOUNDATION AND FOOTING ELEVATION DETAIL FOR SQUARE TUBES

TYPE 4 FOOTING

POST AND FOOTING

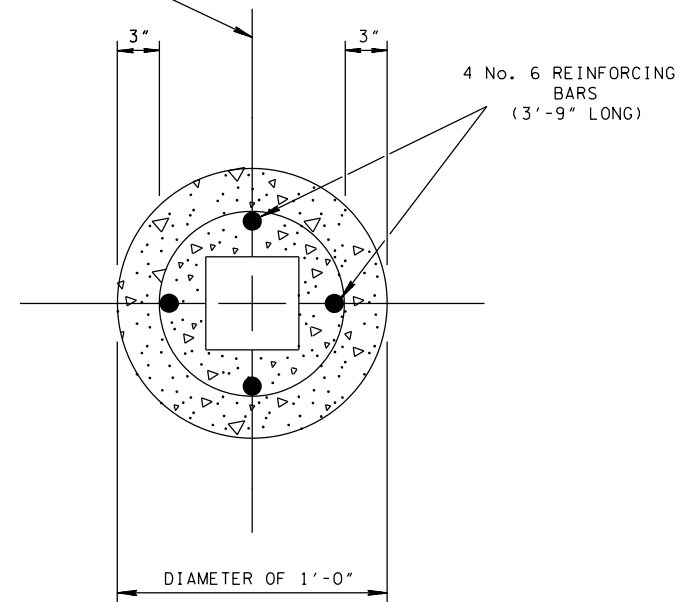

SECTION E-E TYPE 4 FOOTING

PROCEDURE FOR ASSEMBLY OF BASE CONNECTION

- ① ASSEMBLE POST TO STUB WITH BOLTS AND ONE BOLT KEEPER PLATE BETWEEN THEM.
- ② SHIM AS REQUIRED TO PLUMB POST.
- ③ TIGHTEN ALL BOLTS THE MAXIMUM POSSIBLE WITH 12" TO 15" WRENCH TO BED WASHERS AND SHIMS AND TO CLEAN BOLT THREADS, THEN LOOSEN.
- ④ RETIGHTEN BOLTS IN A SYSTEMATIC ORDER TO THE PRESCRIBED TORQUE (SEE TABLE).
- ⑤ BURR THREADS AT JUNCTION WITH NUT USING A CENTER PUNCH TO PREVENT NUT LOOSENING.

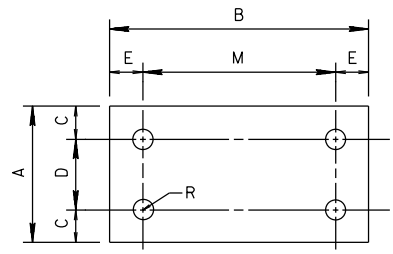

BOLT KEEPER PLATE (28 GAUGE GALVANIZED STEEL)

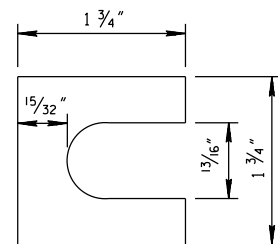

SHIM DETAIL

THE THICKNESS OF SHIMS SHALL NOT BE MORE THAN 0.032" NOR LESS THAN 0.012" AT ANY SINGLE BOLT. SHIMS SHALL BE FABRICATED FROM BRASS SHIM STOCK OR STRIP CONFORMING TO ASTM-B36.

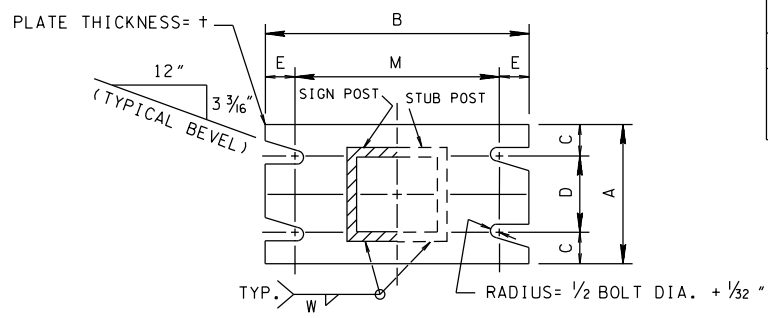

SECTION A-A SECTION B-B SEE TABLE FOR DIMENSIONS

SECTIONS SHOWN ARE FOR INSTALLATIONS ON RIGHT SHOULDER AND IN GORE AREAS. PLATE SLOT LEVELS ARE OPPOSITE DIRECTION FROM THAT SHOWN FOR INSTALLATIONS ON LEFT SHOULDER.

GENERAL NOTES

- (A) THE DESIGN CONFORMS WITH THE AASHTO STANDARD SPECIFICATIONS FOR STRUCTURAL SUPPORTS FOR HIGHWAY SIGNS, LUMINAIRES AND TRAFFIC SIGNALS (CURRENT EDITION).
- (B) THE MATERIALS AND FABRICATION SHALL CONFORM TO THE STANDARD SPECIFICATIONS OF THE TENNESSEE DEPARTMENT OF TRANSPORTATION.
- (C) ALL STEEL SHALL BE GALVANIZED AFTER FABRICATION IN ACCORDANCE WITH STANDARD SPECIFICATION ASTM-A123 FOR SIGN SUPPORTS.
- (D) ALL HIGH STRENGTH BOLTS AND WASHERS SHALL CONFORM TO STANDARD SPECIFICATION ASTM-A325 OR SAE GRADE 5.
- (E) ALL HIGH STRENGTH NUTS SHALL BE OF SUCH CAPACITY AS TO DEVELOP THE BOLT STRENGTH.
- (F) TIGHTEN THE HIGH STRENGTH BOLTS IN THE BASE CONNECTION ONLY TO THE TORQUE SHOWN. CAUTION - DO NOT OVERTIGHTEN.
- (G) ALL BOLT, NUTS AND WASHERS OTHER THAN LABELED HIGH STRENGTH SHALL CONFORM TO STANDARD SPECIFICATION ASTM-A307, CLASS A.
- (H) THE WELDING SHALL BE DONE IN ACCORDANCE WITH THE AASHTO STANDARD SPECIFICATIONS FOR STRUCTURAL SUPPORTS FOR HIGHWAY SIGNS, LUMINAIRES AND TRAFFIC SIGNALS (CURRENT EDITION).
- (I) ALL BOLTS AND NUTS SHALL BE COATED WITH A SUITABLE LUBRICANT.
- (J) THE MATERIAL USED FOR STRUCTURAL SHAPES AND PLATES SHALL BE ASTM-A36 GRADE STEEL.
- (K) ALL HIGH STRENGTH BOLTS, NUTS AND WASHERS MAY BE CADMIUM PLATED IN ACCORDANCE WITH STANDARD SPECIFICATION ASTM-A165 OR GALVANIZED IN ACCORDANCE WITH STANDARD SPECIFICATION ASTM-A153.
- (L) CLASS "A" CONCRETE CONSTRUCTION AND MATERIALS SHALL MEET THE REQUIREMENTS OF THE "STANDARD SPECIFICATIONS FOR ROAD AND BRIDGE CONSTRUCTION OF THE TENNESSEE DEPARTMENT OF TRANSPORTATION, SECTION 604".
- (M) CLASS "A" CONCRETE AND REINFORCING STEEL USED IN CONJUNCTION WITH INSTALLATION OF THE SIGN SUPPORT POSTS TO BE PAID FOR UNDER ITEM NOS. 713-01.01, CLASS "A" CONCRETE (FOUNDATION FOR SIGN SUPPORTS) PER CUBIC YARD, AND 713-01.02, STEEL BAR REINFORCEMENT (FOUNDATION FOR SIGN SUPPORTS) PER POUND.
- (N) CLASS "A" CONCRETE FOOTING SHALL BE PLACED ONLY ON UNDISTURBED MATERIAL OR IN FILL MATERIAL PLACED BY CONTROLLED COMPACTION AT DEPTHS UNAFFECTED BY FROST.
- (O) MATERIALS SURROUNDING FOOTING SHALL BE CAPABLE OF CARRYING A MINIMUM BEARING OF 2,500 POUNDS PER SQUARE FOOT. WHERE SOLID ROCK IS ENCOUNTERED, FOOTING SHALL BE LENGTH SHOWN ON THE SIGN SCHEDULE SHEET OR EXTEND A MINIMUM OF TWO FEET INTO THE ROCK.
- (P) TO BE PAID FOR UNDER ITEM NO. 713-11.21 - P POST SLIP BASE  
713-11.22 - U POST SLIP BASE  
713-11.23 - ROUND POST SLIP BASE

- REV. 10-6-66: BOLT LENGTH AND NOTE.
- REV. 10-27-66: FOUNDATION BEARING REVISED.
- REV. 10-30-66: 3 1/2", 4" & 5" TUBES ELIMINATED.
- REV. 1-19-72: TORQUE FOR DETAIL "A".
- REV. 7-1-72: CHANGED DEPARTMENT NAME.
- REV. 5-1-73: REVISED SHIM NOTE.
- REV. 3-12-74: REVISED GENERAL NOTES.
- REV. 10-3-75: TORQUE ON BOLT AND POST SIZE.
- REV. 1-1-76: CHANGED DWG. NO. FROM RD-S-13 TO T-S-13.
- REV. 7-29-76: NEW AASHTO SPECIFICATION.
- REV. 4-12-77: BOLTS AT FUSE PLATES & ADDED BOLT KEEPER PLATES.
- REV. 6-30-88: ADDED HINGE PLATE.
- REV. 3-14-90: CHANGE SLIP BASE TORQUE IN TABLE.
- REV. 12-7-90: DREW NEW SHEET INCLUDING INFORMATION PREVIOUSLY ON DRAWING NUMBER T-S-13 REGARDING STANDARD STEEL GROUND MOUNTED SIGNS WITH BREAK-AWAY TYPE FOOTINGS USING SQUARE TUBE SUPPORTS.
- REV. 10-26-96: CHANGED PAY ITEM NO. IN GENERAL NOTE (M).
- REV. 5-27-01: CHANGED NOTE UNDER SHIM DETAIL.
- REV. 5-27-03: CORRECTED GENERAL NOTE (B).
- REV. 7-2-15: REVISED TUBE SIZE. ADDED GENERAL NOTE (P).
- REV. 7-10-2017: CHANGED PAY ITEM NO. IN GENERAL NOTE (P).

TUBE SIZE	BOLT SIZE AND TORQUE	BASE CONNECTION DIMENSIONS								FOUNDATION
		A	B	C	D	E	M	t	W	DIAMETER OF TYPE 4 FOOTING
2" Ø @ 3.12 #/FT	1/2" Ø x 2" TORQUE = 95 in. lbs.	4 1/2"	6 1/4"	1"	2 1/2"	3/4"	4 3/4"	1/2"	1/4"	1'-0"
2 1/2" Ø @ 3.98 #/FT	1/2" Ø x 2 1/2" TORQUE = 95 in. lbs.	4 1/2"	7 1/4"	1"	2 1/2"	3/4"	5 3/4"	1/2"	5/16"	
3" Ø @ 4.83 #/FT	1/2" Ø x 2 1/2" TORQUE = 95 in. lbs.	4 1/2"	8"	1"	2 1/2"	3/4"	6 1/2"	3/4"	5/16"	

MINOR REVISION -- FHWA APPROVAL NOT REQUIRED.