

8/22/2017 8:44 AM P:\Traffic Operations Division\Traffic\DESIGN\Standard Drawings\Signals (SG)\IN PROGRESS\Group started 7-11-17\TSG7A-S-Jordan.dgn

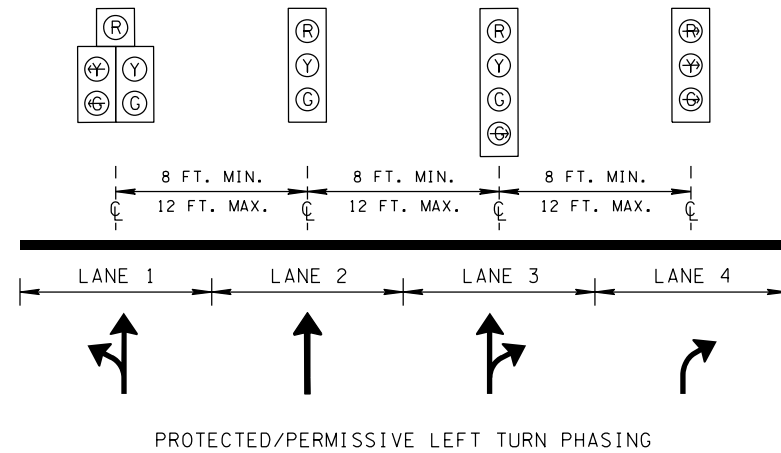
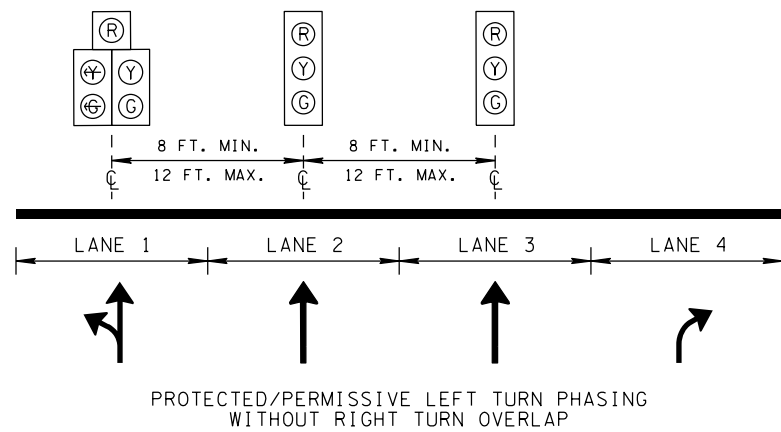
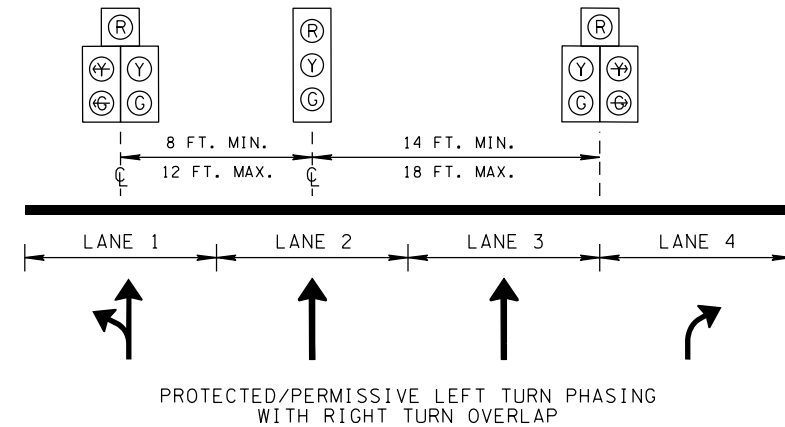
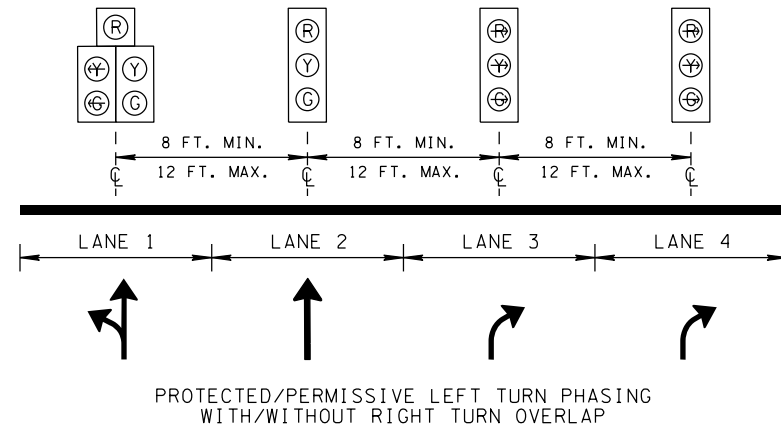
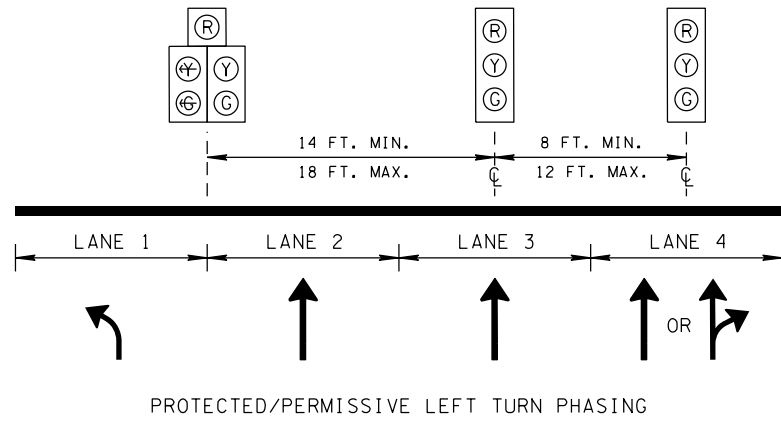
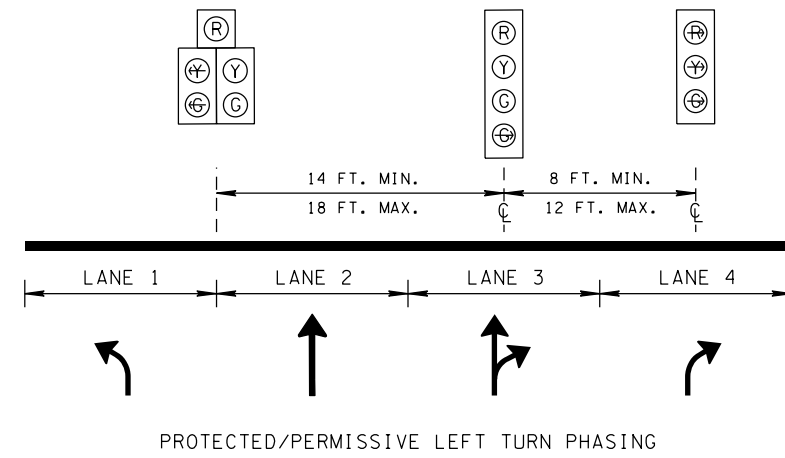
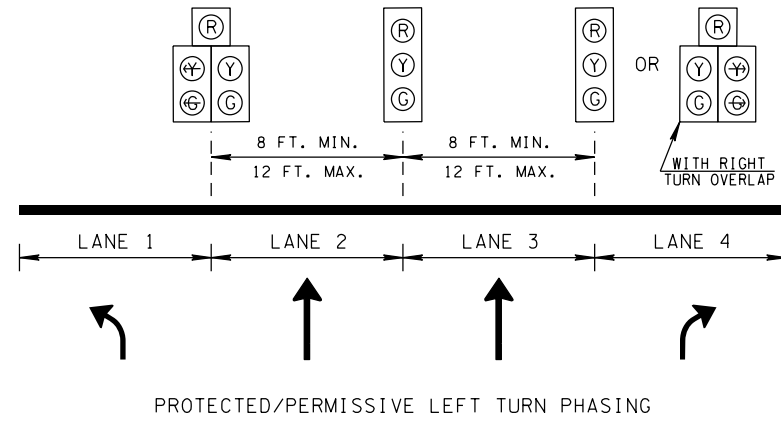
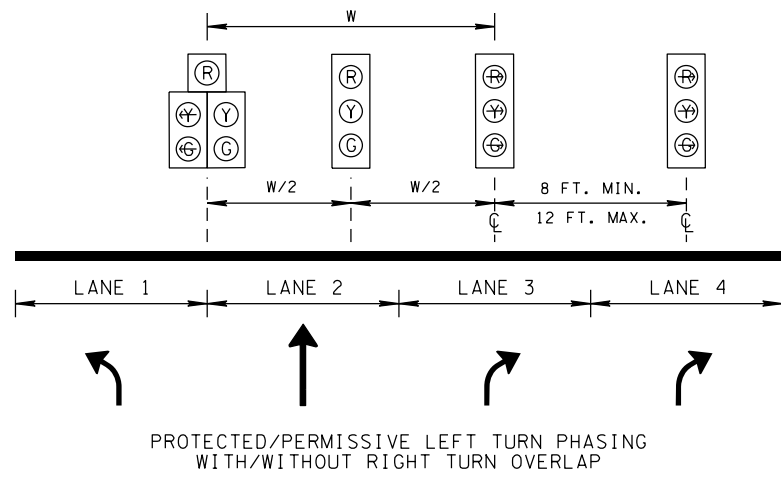

REV. 7-13-17: RENAMED SHEET TO T-SG-7HH. REMOVED ARROWS FROM LANE 3 SIGNAL HEAD ON PROTECTED/PERMISSIVE LEFT TURN PHASING WITHOUT RIGHT TURN OVERLAP.

NOTE 1: WHERE THERE IS AN OPPOSITE LEFT TURN LANE APPROACH IN THE SAME ALIGNMENT AS THE LEFT TURN LANE, THE LEFT TURN SIGNAL HEAD IS OFFSET TWO FEET (MIN.) CLOSER TO THE THROUGH LANE IN ORDER TO INCREASE THE APPROACH'S SIGNAL HEAD VISIBILITY.

NOTE 2: SEE THE CURRENT EDITION OF THE MUTCD FOR ADDITIONAL INFORMATION REGARDING SIGNAL HEAD PLACEMENTS.

STATE OF TENNESSEE  
DEPARTMENT OF TRANSPORTATION

TYPICAL SIGNAL  
HEAD PLACEMENT

FOUR-LANE APPROACHES

6-27-16 T-SG-7HH