

TYPICAL HIGH SPEED APPROACH*

* REQUIRES PHASE RECALL OR PHASE DETECTOR UNIT SETTING LOCKED

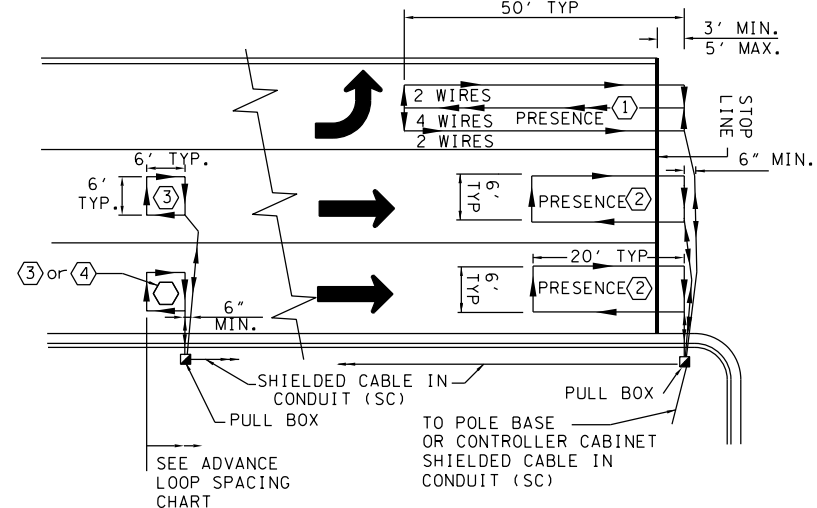

ALTERNATE HIGH SPEED APPROACH**

** FOR USE WHEN PRESENCE DETECTION IS REQUIRED

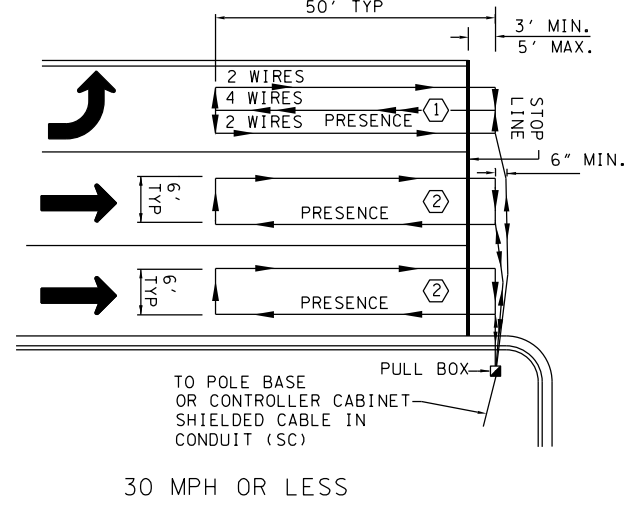

30 MPH OR LESS

(2) = DETECTOR NO. (LOOPS WITH SAME NUMBER INDICATES WIRED IN SERIES)
ALL LOOPS TO BE CENTERED IN TRAVEL LANE
ALL DISTANCES ARE FROM THE STOP LINE

TYPICAL LOOP DETECTOR INSTALLATION LAYOUT

*** REFER TO T-SG-2 FOR PULL BOX CONDUIT DETAILS

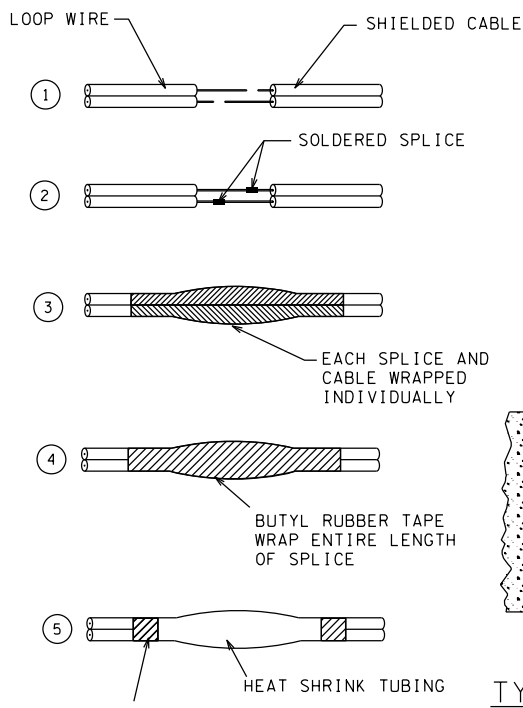

SPLICE DETAILS

NOTE: FINISHED SPLICE MUST BE WATERPROOF.

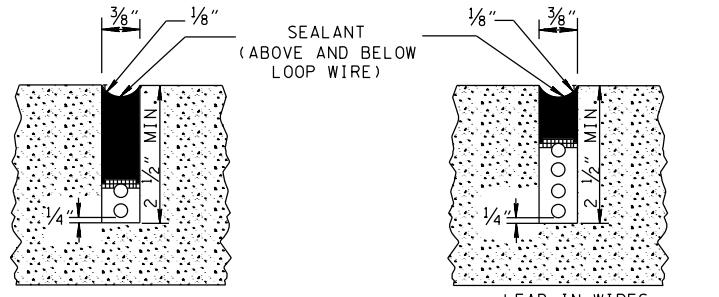
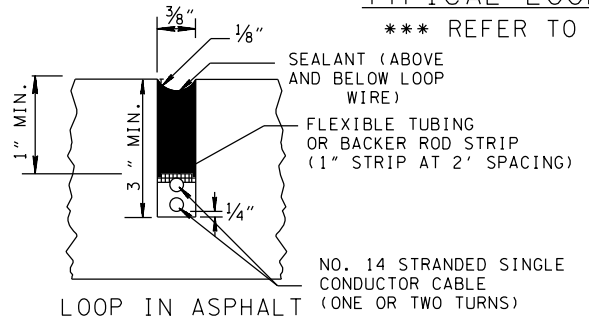

LOOP IN ASPHALT
LOOP IN CONCRETE
TYPICAL SAW SLOT & LOOP WIRE DETAIL

ADVANCE LOOP SPACING			
APPROACH VEHICULAR SPEED (MPH)	BEGIN OF INDECISION ZONE (5.5 SECONDS FROM STOP LINE) (FEET)	END OF INDECISION ZONE (2.5 SECONDS FROM STOP LINE) (FEET)	SETBACK DETECTION PLACEMENT DISTANCE FROM STOP LINE (FEET)
35	285	125	285
40	325	145	325
45	365	165	365
50	405	180	405
55	445	200	445
60	485	220	485

LOOP TURNS		
LOOP LENGTH	NO. TURNS IN ASPHALT	NO. TURNS IN CONCRETE
6-24	3	4
24-50	2	3
QUADRAPOLE	2-4-2	3-6-3

INDUCTION DETECTION LOOP NOTES

- (A) THE DETECTION LOOPS SHALL BE OF THE SIZE AND LOCATION DETAILED IN THE PLANS UNLESS OTHERWISE DIRECTED BY THE ENGINEER.
- (B) THE CONTRACTOR SHALL INSTALL LOOPS BY WET CUTTING A NARROW SLOT (3/8 INCH WIDE) IN THE ROADWAY SURFACE WITH A DIAMOND SAW, INSTALLING THE WIRE AND BACKFILLING WITH A SUITABLE SEALER. SAW SLOTS SHALL BE A MINIMUM OF 3" IN DEPTH IN BITUMINOUS PAVEMENT, AND A MINIMUM OF 2 1/2" IN DEPTH IN CONCRETE PAVEMENT.
- (C) THE CONTRACTOR SHALL EXERCISE CARE IN PLACING THE DETECTION LOOPS AND LEAD-INS IN THE PAVEMENT SLOTS. PRESSURE CLEAN WITH WATER, THEN FILTERED COMPRESSED AIR SHALL BE USED TO REMOVE ALL DUST AND MOISTURE FROM THE SLOT. THE LOOP WIRE WILL THEN BE PUSHED INTO THE SLOTS WITHOUT THE USE OF SHARP OBJECTS WHICH MIGHT DAMAGE THE WIRE INSULATION. USE OF METAL TOOLS IS NOT PERMITTED.
- (D) THE DETECTION LOOPS IN ANY GIVEN TRAFFIC LANE SHALL BE WIRED TOGETHER IN SERIES TO ENTER ONE DETECTOR SENSOR UNIT UNLESS OTHERWISE NOTED ON THE PLANS. IF THE MANUFACTURER OF THE RELATED DETECTOR SENSOR UNIT RECOMMENDS ANOTHER WIRING SCHEME, APPROVAL SHALL BE OBTAINED FROM THE ENGINEER BEFORE CHANGING THE WIRING.
- (E) BEFORE THE SLOTS ARE SEALED, THE RESISTANCE OF THE DETECTION LOOPS AND LEAD-INS (INCLUDING SPLICES) SHALL BE CHECKED AGAINST GROUND WITH A MEGGAR. A RESISTANCE OF LESS THAN TEN MEGAOHMS WILL INDICATE A FAULT REQUIRING CORRECTION BEFORE THE SLOT IS SEALED.
- (F) ALSO BEFORE THE SLOTS ARE SEALED, THE INDUCTANCE OF THE DETECTION LOOP AND LEAD-INS SHALL BE CHECKED AT THE LOCATION OF THE DETECTOR SENSOR UNIT. THE INDUCTANCE SHALL BE NO LESS THAN 50 MICROHENRIES AND NO MORE THAN 300 MICROHENRIES. IF IT MEASURES OUT OF THIS RANGE ADDITIONAL TURNS SHALL BE ADDED OR SPLICING OF THE LOOPS (SERIES AND/OR PARALLEL) SHALL BE CHANGED TO PROVIDE AN INDUCTANCE READING BETWEEN 50 AND 300 MICROHENRIES.
- (G) AFTER THE LOOP WIRES ARE INSTALLED AND ALL CHECKS SATISFACTORILY COMPLETED, A ONE INCH STRIP OF BACKER ROD OR FLEXIBLE TUBING SHALL BE INSERTED AT APPROXIMATE TWO FOOT INTERVALS TO HOLD THE LOOP IN PLACE. THESE HOLD DOWN STRIPS SHALL BE A MINIMUM OF 1/2" INCH FROM THE PAVEMENT SURFACE. THE SLOT SHALL THEN BE BACKFILLED AND SEALED WITH AN APPROVED LOOP SEALANT TO WITHIN 1/8" OF THE PAVEMENT SURFACE. SURPLUS SEALANT SHALL BE REMOVED FROM THE ADJACENT ROAD SURFACE WITHOUT THE USE OF SOLVENTS. ASPHALTIC BASED SEALERS ARE NOT ACCEPTABLE.
- (H) LOOPS AND HOME RUNS TO PULL BOXES SHALL BE ONE CONTINUOUS LENGTH OF NO. 14 AWG STRANDED CROSS-LINK POLYETHYLENE SINGLE CONDUCTOR WIRE, WHICH MEET THE REQUIREMENTS OF I.M.S.A. SPECIFICATION NO. 51-3. THE HOME RUN TO THE PULL BOX SHALL BE TWISTED 3 TIMES PER FOOT.
- (I) SPLICES SHALL BE PERMITTED ONLY IN PULL BOXES, POLE BASES, CONDULETS, OR CABINETS AND SHALL BE SOLDERED AND WATERPROOF.
- (J) ALL CABLE FROM PULL BOX TO CONTROLLER SHALL CONSIST OF A TWISTED PAIR OF SHIELDED CABLES, NO. 14 AWG STRANDED, WHICH MEET THE REQUIREMENTS OF I.M.S.A. SPECIFICATION NO. 50-2.
- (K) ALL CABLES ARE TO BE COLOR-CODED. ALL LOOP LEAD-INS ARE TO BE LABELED IN PULL BOXES, SHIELDED CABLE TO BE LABELED IN CONTROLLER CABINETS.
- (L) NO LOOPS ARE TO BE INSTALLED THROUGH, OVER, OR UNDER TRANSVERSE CONCRETE JOINTS IN CONCRETE PAVEMENT, AND NO MANHOLES, INLETS, ETC. MAY BE LOCATED WITHIN A LOOP. IF ANY OF THE ABOVE ARE ENCOUNTERED THE LOCATION OF THE LOOP MAY BE VARIED SLIGHTLY AS DIRECTED BY THE ENGINEER. IF THE ABOVE ITEMS ARE UNAVOIDABLE, SMALLER LOOPS IN SERIES MAY BE USED. SMALLER LOOPS USED TO REPLACE ONE LARGE LOOP MAY BE CONNECTED TO ONE CHANNEL.

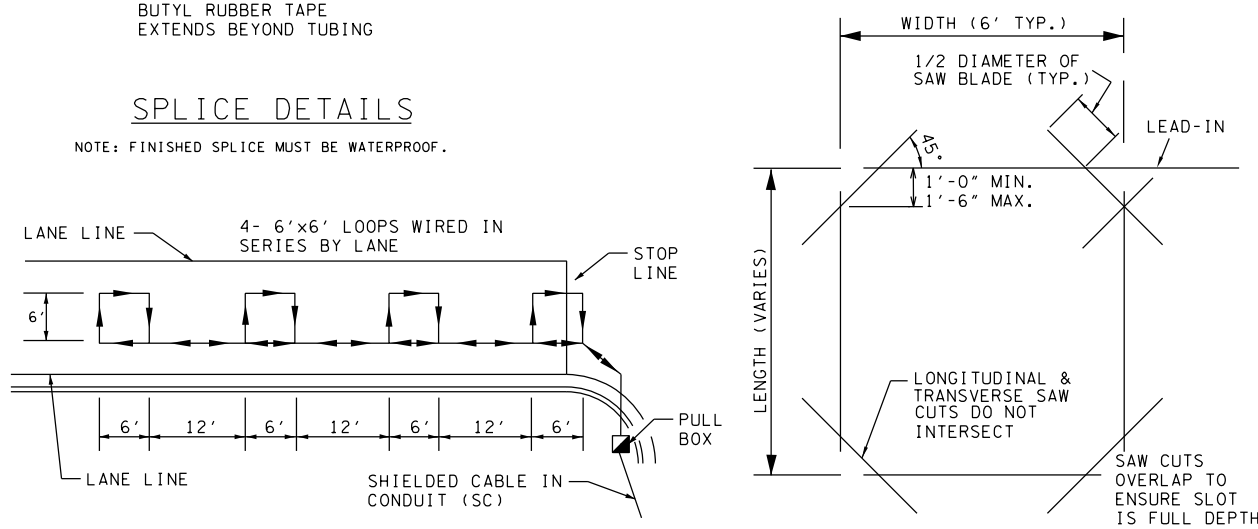

ALT. LAYOUT OF LOOP DETECTORS (FOR PRESENCE DETECTION)

SAW SLOT CONSTRUCTION DETAIL

- REV. 7-1-72: CHANGED DEPARTMENT NAME.
- REV. 4-17-75: RELOCATED STOP LINE ON TYPICAL LAYOUT OF DETECTION LOOPS.
- REV. 11-4-75: CHANGED SAW SLOT DEPTH ON TYPICAL DETAIL FOR ASPHALT. REMOVED NOTE CONCERNING A STABLE ENVIRONMENT FOR THE LOOP.
- REV. 1-1-76: CHANGED DWG. NO. FROM TR-S-3 TO T-SG-3.
- REV. 4-4-77: CHANGED DEPTH OF CUT FOR LOOP WIRE IN ASPHALT FROM 4" TO 2".
- REV. 9-27-77: CORRECTED DEPTH OF CUT FROM 4" TO 2" IN GENERAL NOTE NO. (B).
- REV. 4-12-85: GENERAL REVISIONS TO NOTES AND DETAILS.
- REV. 8-3-87: CHANGED LOOP LEAD-INS ON LAYOUT OF DETECTOR LOOPS DETAIL, ADDED DETAILS FOR #14 GAUGE CABLE IN LOOP AND SPLICING, ADDED NOTE FOR 3/8" SAW SLOT FOR LEAD-INS AND DIMENSIONED DIAGONAL CUTS FOR LOOPS, ADDED NOTE NO. (N), CHANGED NOTE NOS. (C) & (H) TO DELETE "OR EQUIVALENT" AND ADDED "BACKER ROD". CHANGED DIMENSIONS ON SAW SLOT DETAIL.
- REV. 10-27-89: DELETED ALL REFERENCES OF 1/4" SAW SLOT. ADDED QUADRAPOLE LOOP DIAGRAM. DELETED NOTE NO. (N).
- REV. 8-22-91: CHANGED NOTES (B), (C) AND (H). INCREASED DEPTH OF SAW CUT TO 3" FOR ASPHALT AND TO 2 1/2" FOR CONCRETE. CHANGED SAWCUT CORNER DETAIL.
- REV. 4-15-96: REDREW SHEET, REORGANIZED SHEET, AND UPDATED TO 1996 STANDARDS.
- REV. 12-16-13: REVISED LOOP LAYOUTS. REMOVED BACKER RODS FROM BOTTOM OF SAW SLOT, ADDED SAW SLOT DETAIL, ADDED DETAIL FOR LOOPS AT JOINTS, REVISED NOTES, ADDED DETAIL FOR ALT. LAYOUT OF PRESENCE LOOPS.
- REV. 7-29-04: REDREW, RENAMED AND REDESIGNED SHEET.
- REV. 11-11-04: ADDED PATTERN TO SEALANT FOR LOOP IN ASPHALT DETAILS.
- REV. 6-27-16: ADDED SEALANT DIMENSION TO LOOP IN CONCRETE DETAIL. CORRECTED SPELLING ERROR IN INDUCTION DETECTION LOOP NOTES.
- REV. 7-11-17: ADDED BEGIN AND END OF INDECISION ZONE COLUMNS TO THE ADVANCE LOOP SPACING TABLE AND UPDATED VALUES.

MINOR REVISION -- FHWA APPROVAL NOT REQUIRED.

STATE OF TENNESSEE
DEPARTMENT OF TRANSPORTATION

STANDARD NOTES AND DETAILS OF INDUCTIVE LOOPS

JUNE 1972 T-SG-3

7/13/2017 10:03 PM P:\Traffic Operations Division\Traffic\DESIGN\Standard Drawings\Signals (SG)\IN PROGRESS\Group started 7-11-17\TSG3_Jordan-F.dgn