

PROTECTED/PERMISSIVE LEFT TURN PHASING

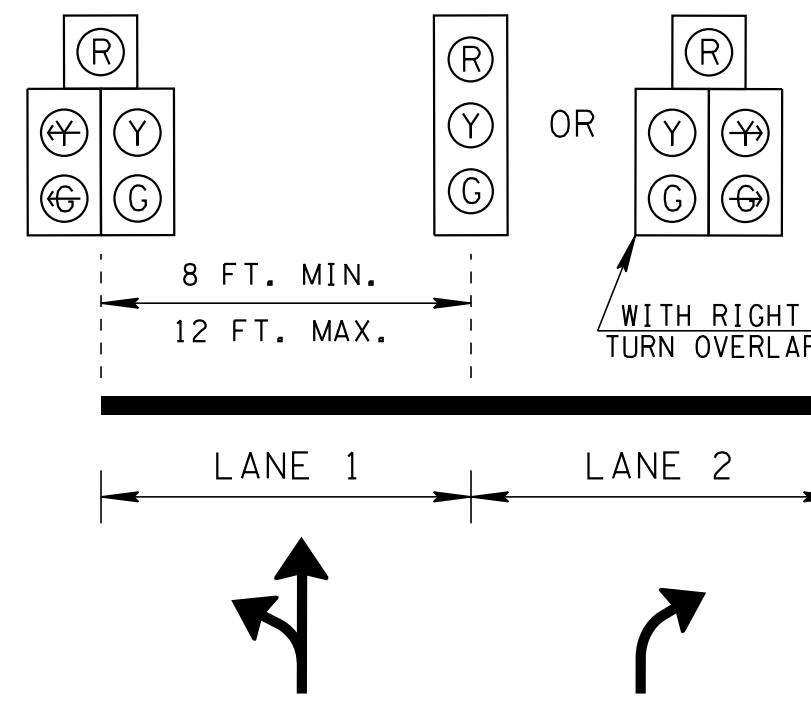

PROTECTED/PERMISSIVE LEFT TURN PHASING

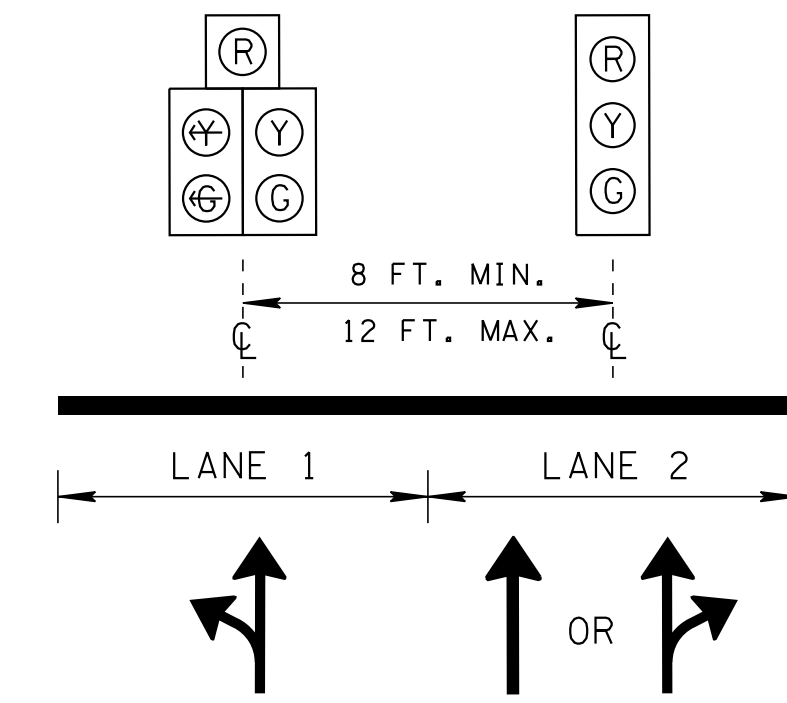

PROTECTED/PERMISSIVE LEFT TURN PHASING

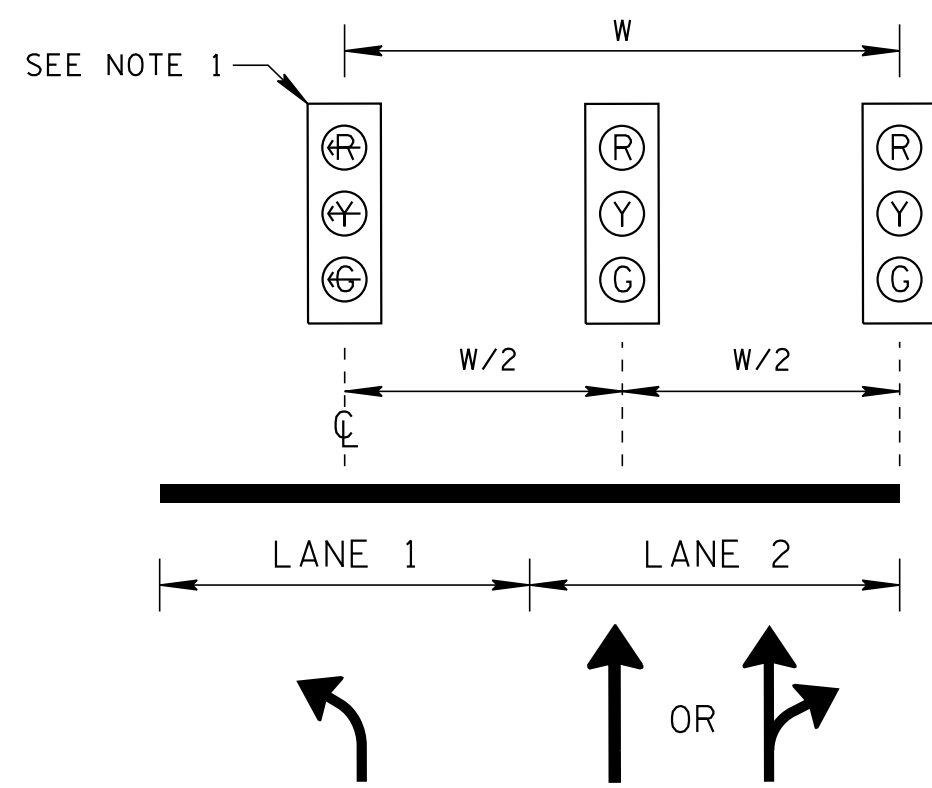

PROTECTED LEFT TURN OR SPLIT PHASING

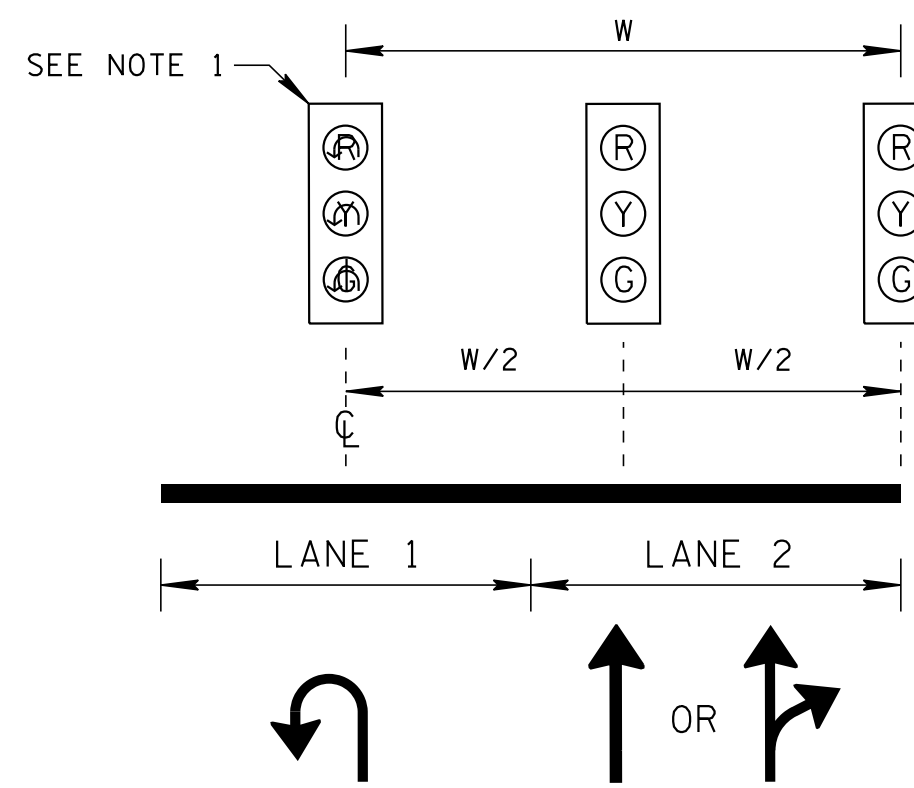

PROTECTED U-TURN OR SPLIT PHASING

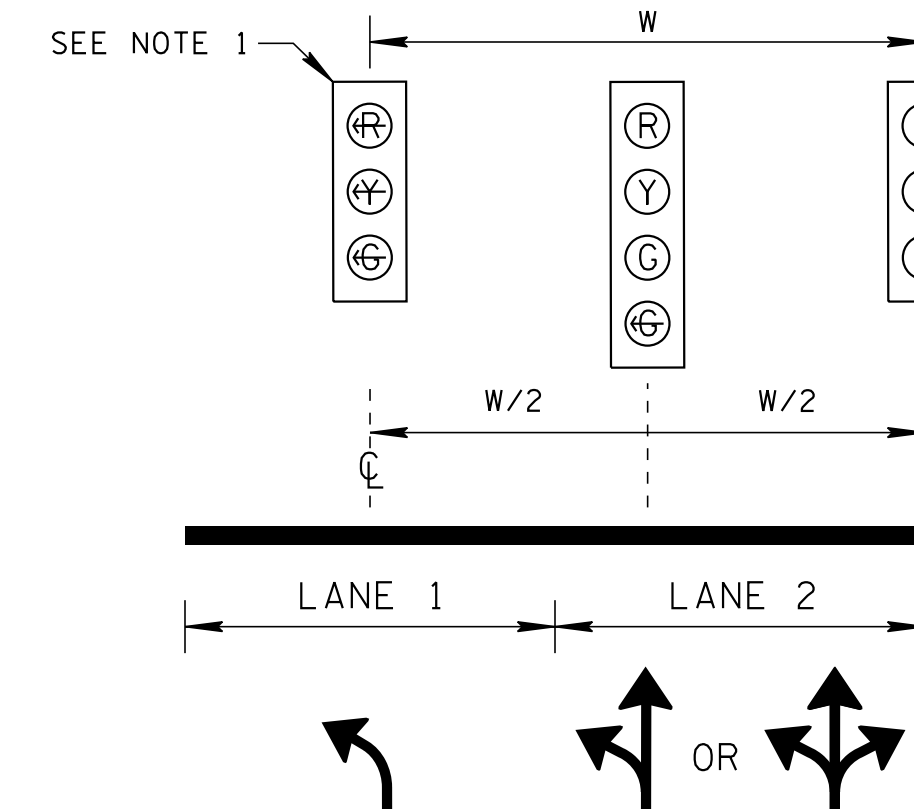

PROTECTED LEFT TURN OR SPLIT PHASING

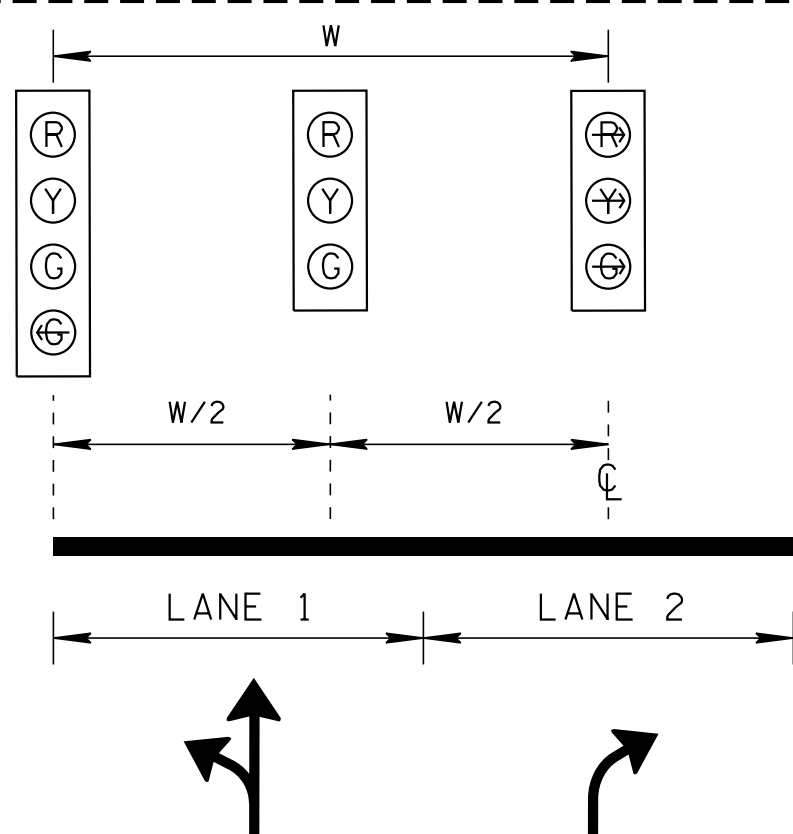

PROTECTED LEFT TURN OR SPLIT PHASING

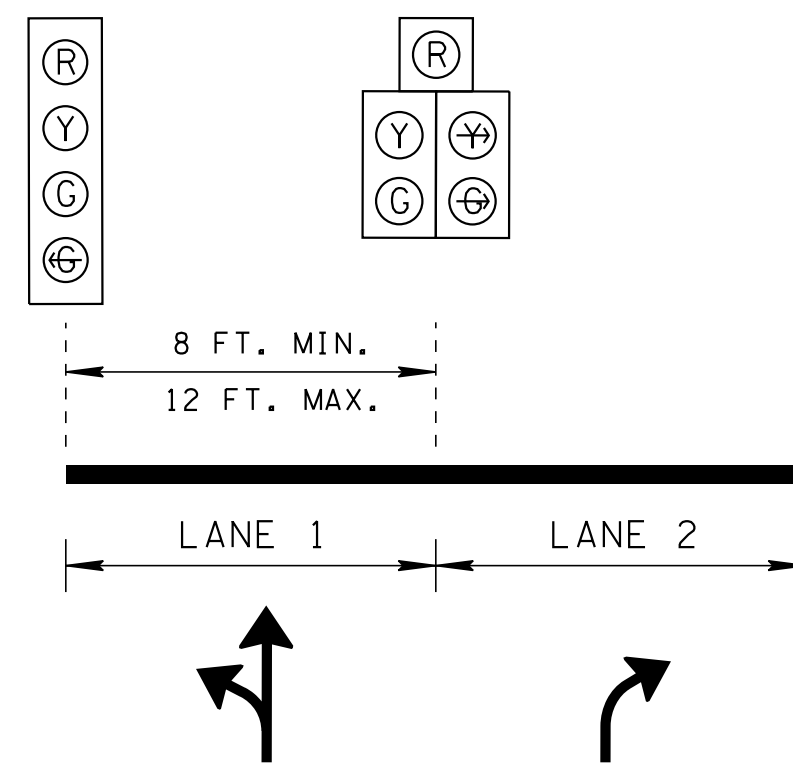

PROTECTED LEFT TURN OR SPLIT PHASING WITH RIGHT TURN OVERLAP

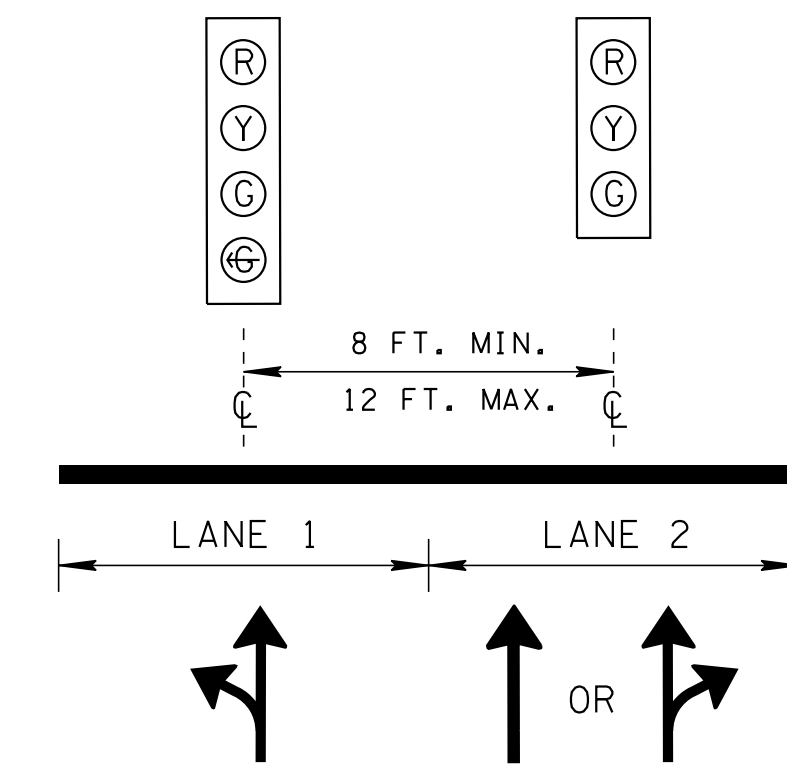

PROTECTED LEFT TURN OR SPLIT PHASING

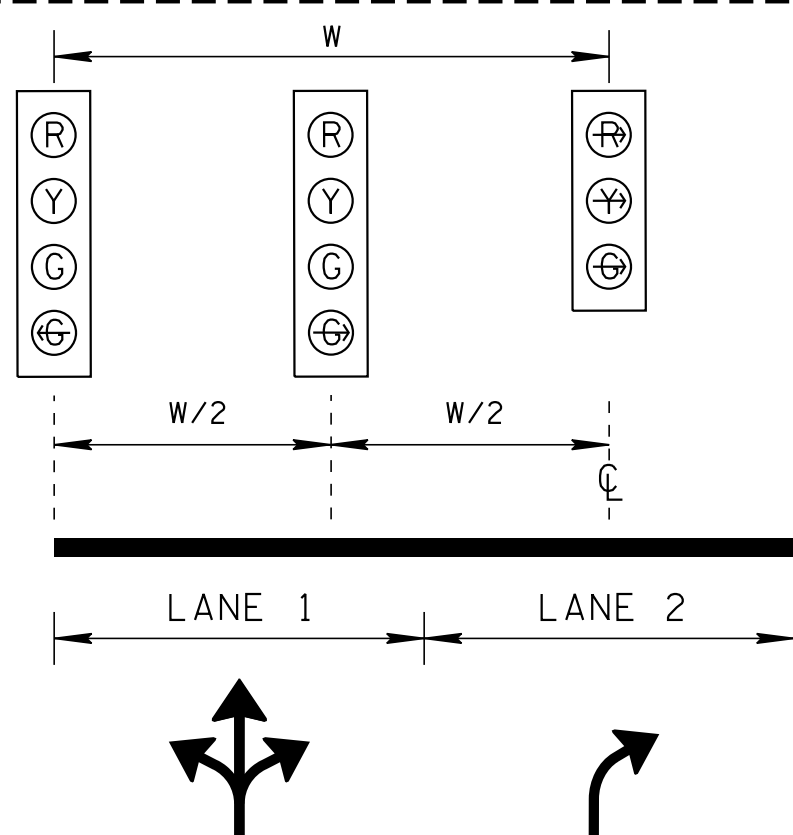

PROTECTED LEFT TURN OR SPLIT PHASING

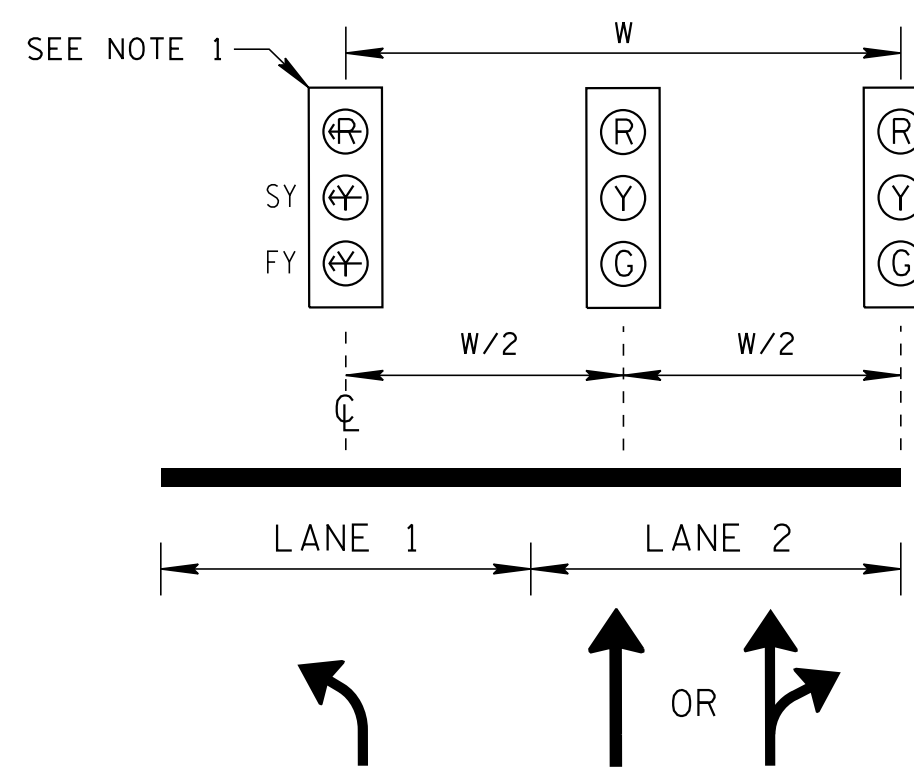

FLASHING YELLOW ARROW PERMISSIVE LEFT TURN PHASING

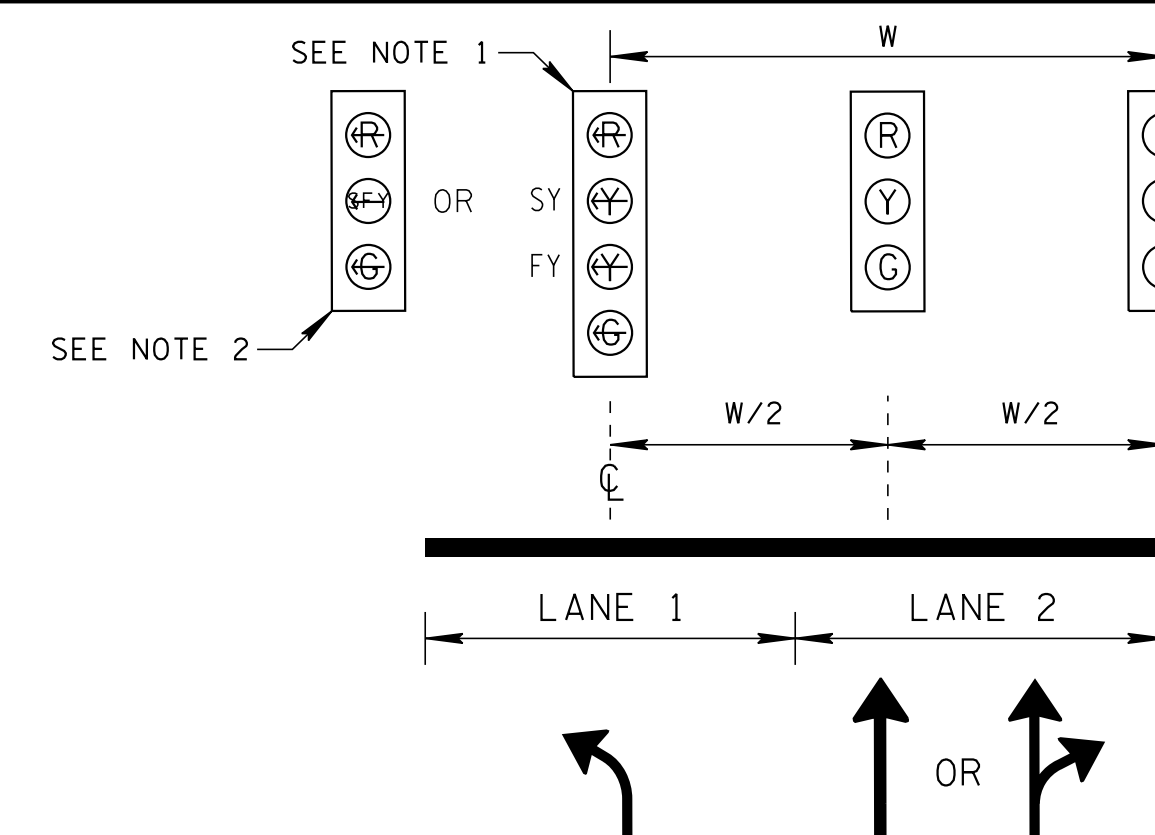

FLASHING YELLOW ARROW PROTECTIVE/PERMISSIVE LEFT TURN PHASING

- REV. 10-21-19: RENAMED NOTE 2 TO NOTE 3. ADDED NOTE 2 AND "SEE NOTE 2" LABELS.
- REV. 09-12-23: ADDED A SIGNAL HEAD AND ADJUSTED LAYOUT FOR SIGNAL PLACEMENT ON ROW 2 COLUMN 3.

| LEGEND | |
|--------|------------------------------------|
| SY | = STEADY YELLOW ARROW |
| FY | = FLASHING YELLOW ARROW |
| SFY | = STEADY AND FLASHING YELLOW ARROW |

□ MINOR REVISION -- FHWA APPROVAL NOT REQUIRED.

NOTE 1: WHERE THERE IS AN OPPOSITE LEFT TURN LANE APPROACH IN THE SAME ALIGNMENT AS THE LEFT TURN LANE, THE LEFT TURN SIGNAL HEAD IS OFFSET TWO FEET (MIN.) CLOSER TO THE THROUGH LANE IN ORDER TO INCREASE THE APPROACH'S SIGNAL HEAD VISIBILITY.

NOTE 2: THIS TRAFFIC SIGNAL HEAD CAN ONLY BE USED THROUGH INTERIM APPROVAL 17 (IA-17) OPTIONAL USE OF THREE SECTION FLASHING YELLOW ARROW SIGNAL FACE. CONTACT TDOT'S STATE TRAFFIC ENGINEER TO REQUEST PERMISSION AND OBTAIN APPROVAL TO UTILIZE THIS TRAFFIC SIGNAL HEAD.

NOTE 3: SEE THE CURRENT EDITION OF THE MUTCD FOR ADDITIONAL INFORMATION REGARDING SIGNAL HEAD PLACEMENTS.

STATE OF TENNESSEE
DEPARTMENT OF TRANSPORTATION

TYPICAL SIGNAL HEAD PLACEMENT

TWO-LANE APPROACHES

9/12/2023 4:23:05 PM C:\Users\jij0223\Documents\STD DWG\Drawings\TSG7A-S-09122023.dgn