



HSAM Volume 3: GEOMETRIC DESIGN CRITERIA

Tennessee Department of Transportation | April 2026

VOLUME 3: GEOMETRIC DESIGN CRITERIA

A graphic in the bottom right corner consisting of three grey stars arranged in a triangular pattern, enclosed within a grey circular border.

Table of Contents

Introduction	3-1
Principles of Access Management	3-1
Functional and Contextual Classification	3-1
Intersection Functional Area.....	3-3
Full and Restricted Access Movements	3-4
Access Spacing.....	3-6
General Spacing Requirements.....	3-7
Spacing of Traffic Signals.....	3-9
Spacing of Unsignalized Intersections.....	3-10
Spacing of Driveways	3-10
Number of Entrances per Property	3-15
Access Spacing – Opposite Side of the Roadway	3-16
Spacing of Median Openings.....	3-18
Spacing near Interchange Ramps	3-20
Spacing near Signalized Interchange Ramp Terminals	3-20
Spacing near Free-Flow Interchange Ramp Terminals.....	3-20
Access Geometrics	3-23
Intersection Geometrics	3-23
Intersection Design Vehicle.....	3-23
Turning Lanes	3-24
Left-Turn Lanes.....	3-24
Right-Turn Lane	3-27
Decelerations and Storage Lengths.....	3-29
Turn Lane Taper Rates.....	3-31
Lane Drop After Intersections	3-32
Corner Island Designs.....	3-36
Intersection Grading and Tie-ins	3-38
Intersections Located near the Limits of Construction.....	3-38

Driveway Geometrics.....	3-38
Types of Roadway Access Driveways.....	3-38
Driveway Horizontal Geometry	3-41
Driveway Radius of Curvature (R).....	3-42
Driveway Width (W).....	3-43
Driveway Throat Length (T).....	3-44
Driveway Edge Clearance (E).....	3-46
Driveway Angle (Y).....	3-47
Driveway Corner Clearance (C).....	3-47
Additional Commercial Driveway Requirements	3-49
Driveway Grading & Profile.....	3-50
Grading for Residential Driveways and Field Entrances on Roads Without Curb & Gutter ...	3-51
Grading for All Other Driveways Without Curb & Gutter	3-51
Grading for Driveways on Roads with Curb & Gutter	3-51
Vertical Curves for Driveway Profiles.....	3-53
Driveway Cross Slope	3-53
Driveway Edge	3-53
Driveway Sight Distance	3-53
Multimodal Roadway Design in Driveways.....	3-55
Pedestrian Safety in Driveways	3-56
Medians	3-56
Median Widths.....	3-57
Left Turn Lanes in Medians.....	3-58
Two-Way Left-Turn Lanes.....	3-61
U-Turn Guidance	3-62
U-Turn Geometrics.....	3-62
Large Vehicle Accommodation For U-Turns	3-63
U-turn at Signalized Intersections	3-64
U-turns in Advance of a Signal.....	3-65

U-turns After a Signal.....	3-66
Deviations from Access Manual Criteria	3-67
Deviation Application for Residential and Commercial Driveway Permits.....	3-67
Deviation Application for Highway Design Projects	3-68
Mitigation	3-68
Approval	3-68
Considerations for Private Development.....	3-69
Traffic Impact Studies	3-69
Highway Entrance Permits.....	3-69
References.....	3-70
Appendix	
Appendix A – Driveway Horizontal Geometry Example Figures	
Appendix B – Turn Lane Warrants	

Table of Tables

Table 3-1: Functional and Context Classification Matrix.....	3-3
Table 3-2: Relative Crash Rates for Unsignalized Access Spacing	3-7
Table 3-3: Progression Speed as a Function of Signal Spacing:	3-9
Table 3-4: Required Minimum Spacing of Unsignalized Intersections.....	3-10
Table 3-5: Required Minimum Spacing of Driveways (Urban, Urban Core & Suburban)	3-12
Table 3-6: Required Minimum Spacing of Driveways (Rural & Rural Town).....	3-14
Table 3-7: Required Minimum Spacing of Offset Access Points	3-18
Table 3-8: Required Minimum Spacing of Median Openings.....	3-19
Table 3-9: Required Minimum Access Spacing at Signalized Interchange Ramp Terminals.....	3-21
Table 3-10: Required Minimum Access Spacing at Free-Flow Interchange Ramp Terminals	3-22
Table 3-11: Lane Change and Deceleration Distance.....	3-30
Table 3-12: Queue Storage Length for Exclusive Left-Turn Lanes at Unsignalized Intersections	3-30
Table 3-13: Guidelines for Advance Placement of Warning Signs	3-34
Table 3-14: Typical Driveway Radius of Curvature (R)	3-42
Table 3-15: Required Intersection or Street Type Driveways Radius of Curvature (R).....	3-43
Table 3-16: Required Driveway Width	3-44

Table 3-17: Minimum Driveway Throat Length Requirements	3-45
Table 3-18: Required Edge Clearance (E) for Driveways	3-46
Table 3-19: Required Minimum Corner Clearance	3-49
Table 3-20: Minimum Median Widths for Specific Median Functions.....	3-58
Table 3-21: Future Traffic Signal Warrants.....	3-60
Table 3-22: Minimum Required Median Widths of U-Turn Maneuvers.....	3-62

Table of Figures

Figure 3-1: Intersection Functional Area	3-4
Figure 3-2: Full Access Intersections & Driveways	3-5
Figure 3-3: Restricted Access Driveways (Right in / Right Out).....	3-5
Figure 3-4: Restricted Access Driveway (Right In / Right Out / limited Left-Turns / J-Turns)	3-6
Figure 3-5: Typical Access Point Spacing	3-8
Figure 3-6: Driveway Spacing Upstream of Median Opening (Partial and Full Access)	3-15
Figure 3-7: Adverse Jog Maneuver	3-16
Figure 3-8: Distinct Turning Movements	3-16
Figure 3-9: Conflicting Left-Turn movements	3-16
Figure 3-10: Overlapping Left-Turn Movements with Two-Way Left-Turn Lane.....	3-16
Figure 3-11: Access Configuration to Avoid Overlapping Left-Turn Movements.....	3-17
Figure 3-12: Minimum Spacing of Offset Access Points.....	3-17
Figure 3-13: Access Spacing at Signalized Interchange Ramp Terminals	3-21
Figure 3-14: Access Spacing at Free-Flow Interchange Ramp Terminals.....	3-22
Figure 3-15: Left-Turn Lane Warrant for Urban and Suburban Arterials (Unsignalized).....	3-25
Figure 3-16: Left-Turn Lane Warrant for Two-Lane Rural Roadways (Unsignalized)	3-25
Figure 3-17: Left-Turn Lane Warrant for Four-Lane Rural Roadways (Unsignalized).....	3-26
Figure 3-18: Right-Turn Lane Warrant along Two-Lane Roadway (Unsignalized Intersection with Two-Way Stop-Control)	3-28
Figure 3-19: Right-Turn Lane Warrant along Four-Lane Roadway (Unsignalized Intersection with Two-Way Stop-Control)	3-28
Figure 3-20: Functional Area, for an Exclusive Turn Lane.....	3-30
Figure 3-21: Turning Lane Taper Terminology	3-31
Figure 3-22 Minimum Length (X) for Lane Extensions through an Intersection Width	3-33
Figure 3-23: Right-Turn Corner Island Designs	3-37
Figure 3-24: Horizontal Driveway Geometrics.....	3-41
Figure 3-25: Driveway Throat Length Accommodation for Parking Conflicts	3-46
Figure 3-26: Corner Clearance "C" for Driveways.....	3-48

Figure 3-27: Example of Ground Clearance Issues Related to Driveway Profile. 3-50

Figure 3-28: Driveway Profile Schematic..... 3-52

Figure 3-29: Driveway Sight Distance and Sight Triangles..... 3-54

Figure 3-30: Driveway Sight Distance at Divided Roadways..... 3-55

Figure 3-31: Median Width Measurement 3-57

Figure 3-32: Left-Turn Lane Alignment..... 3-60

Figure 3-33: Jug Handle Designs for Large Vehicle U-Turns 3-64

Figure 3-34: U-Turns at Dual Left-Turn Lanes 3-65

Figure 3-35: U-Turn in Advance of an Intersection. 3-66

Figure 3-36: Schematic of a Median U-Turn Intersection 3-67

Introduction

Access regulations are necessary to preserve the functional integrity of Tennessee's State Routes and to promote the safe and efficient movement of people and goods while providing reasonable access to adjoining property owners. By definition, an access connection is any driveway, public roadway / street, or other means of providing for the movement of vehicles and pedestrians to or from the public roadway system. Reasonable access means that a property owner will have access to the public roadway system, but it does not mean that potential patrons are guaranteed the most direct or convenient access from a specific roadway to the owner's property.

Every access point constructed on a roadway increases the crash risk and deteriorates traffic operations. The cumulative impact of closely spaced access points over time is one of the largest contributors to high crash rates and congestion on State Routes. An effective access management program can reduce crashes by 50 percent, increase roadway capacity by up to 45 percent and reduce travel time and delay by up to 60 percent¹.

The design guidance provided in subsequent pages utilizes national best practices to better preserve the safe and efficient movement of people and goods while also helping property owners make better decisions regarding access needs. Each property is entitled to reasonable access and as such it will not always be practical to provide the desirable access separation distances. When spacing requirements cannot be met, follow the guidance in the section on *Deviations from Access Manual Criteria* for the procedures that must be followed.

Principles of Access Management

Functional and Contextual Classification

Functional classification defines the role of each roadway in serving motor-vehicle movements within the overall transportation system. The functional classification of a roadway suggests its position within the transportation network and its general role in serving automobile, truck, and transit vehicles. For the purposes of access management, these categories include freeways, principal arterials, minor arterials, major collectors, minor collectors, and local roads. Refer to the American Association of State Highway and Transportation Officials (AASHTO) *A Policy on Geometric Design of*

¹ Transportation Research Board (TRB), Access Management Manual 2nd Edition (2014) pg. 5.

Highways and Streets, 7th Edition (also known as the “Green Book”), Section 1.4, for further explanation of functional classification.

Context classification characterizes roadways by their surrounding environment and how the roadway fits into the community. This system considers five context classes: rural, rural town, suburban, urban, and urban core. AASHTO Green Book, 7th Edition, Section 1.5, provides additional details regarding the characteristics of each contextual classification.

Within each classification are intended levels of access and mobility. Access refers to the frequency of driveways or intersections along the corridor while mobility is defined as a function of congestion level. High levels of access correlate to closely spaced driveways and intersections while low access roadways should have little to no access points along the corridor. Freeways and arterials provide high mobility with very low access. Low mobility is associated with congested conditions while high mobility refers to free flowing traffic conditions. Table 3-1 from the National Cooperative Highway Research Program (NCHRP) Report 855 *An Expanded Functional Classification System for Highways and Streets* shows the anticipated levels (H-High / M-Medium / L-Low) of speed, access, and mobility for each corridor classification. Note the Freeway classification has been omitted from this table because it should always be high mobility with restricted access.

Table 3-1: Functional and Context Classification Matrix²

Context Roadway	Rural	Rural Town	Suburban	Urban	Urban Core
Principal Arterial	H speed H mobility- L access	L/M speed M mobility- H access	M/H speed M mobility- M access	L/M speed M mobility- M access	L speed M mobility- M access
Minor Arterial	H speed H mobility- M access	L/M speed M mobility- H access	M speed M mobility- M access	L/M speed M mobility- M/H access	L speed M mobility- M/H access
Collector	M speed M mobility- M access	L speed M mobility- H access	M speed M mobility- H access	L speed M mobility- H access	L speed M mobility- H access
Local	M speed M mobility- M access	L speed M mobility- H access	L speed L mobility- H access	L speed L mobility- H access	L speed L mobility- H access

H = high, M = medium, L = low

Intersection Functional Area

Intersections are comprised of physical and functional areas, as shown in Figure 3-1. The physical extent of an intersection is the area bounded by the intersection legs. The functional area extends upstream and downstream of the intersection and includes the roadway length required for vehicle storage and maneuvering. The upstream functional area of an intersection depends on the vehicle queuing (storage length), driver perception-reaction time, and the distance required for decelerating or stopping. The downstream functional area of an intersection depends on the distance required by the driver to clear the intersection and the distance to perceive and react to a conflict downstream of the intersection.

² TRB, NCHRP Report 855, *An Expanded Functional Classification System for Highways and Streets* (2018)

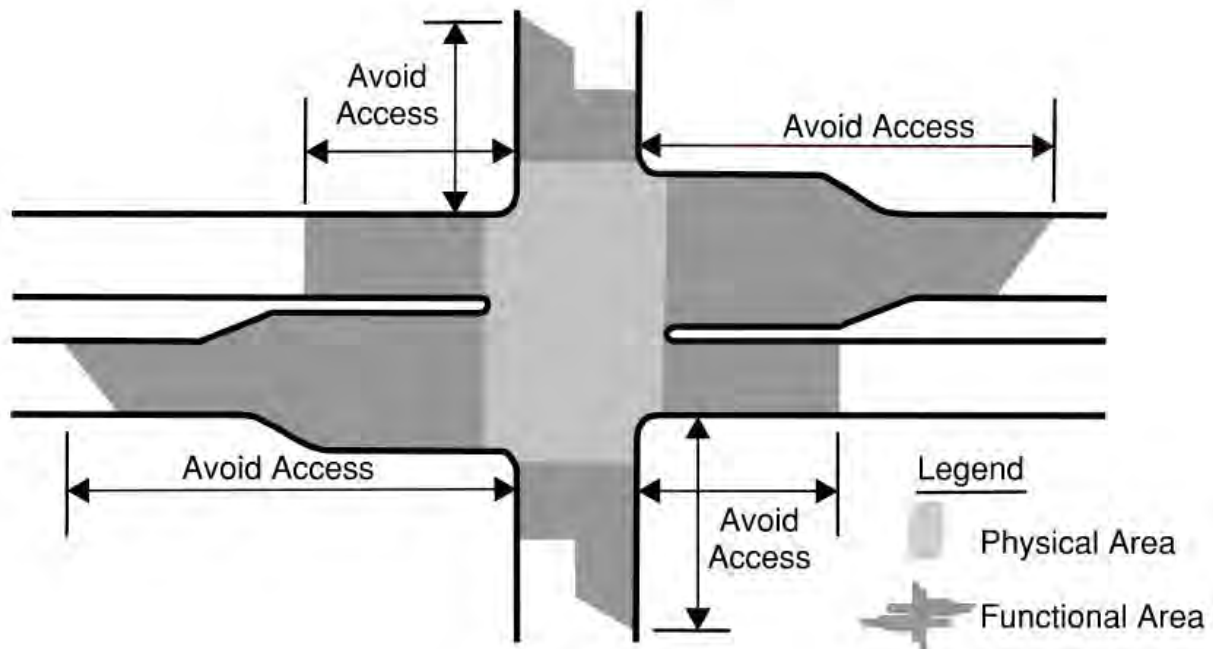

Figure 3-1: Intersection Functional Area [TRB, Access Management Manual, 2014]^{3, 4}

Access connections are not recommended in the intersection functional area. Driveways or median openings within the functional area create conflict points, which the driver approaching or exiting an intersection may not be able to negotiate safely. The functional area of an intersection should be considered when evaluating potential driveway locations. Ideally, the functional areas of adjacent intersections should not overlap. The integrity of the intersection functional area is maintained by intersection spacing, median spacing, driveway spacing, and corner clearance. It is also necessary to understand that calculated values for functional areas are ideal values that may not be feasible for implementation, especially in consolidated urban areas.

Full and Restricted Access Movements

A full access movement refers to an access point in which all left-turning, right-turning, and through movements are allowed and accommodated. Most, though not necessarily all, signalized and unsignalized intersections are designed as a full access median opening. Additionally, entrances with full access median openings or no median are also considered full access. Figure 3-2 provides example

³ TRB, Access Management Manual 2nd Edition (2014)

⁴ University of Tennessee Knoxville (UTK), Center for Transportation Research, Access Management Report (2017)

schematics for full access driveways and intersections. These driveways and intersections will be subject to the spacing requirements of Full Access Driveways and Medians as detailed in the sections of this manual.

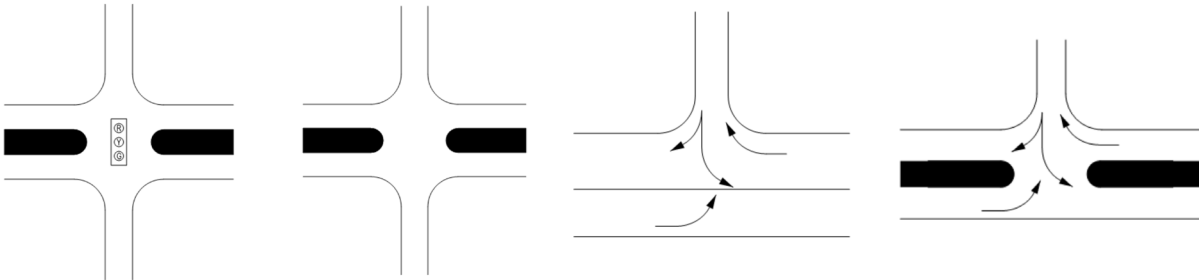

Figure 3-2: Full Access Intersections & Driveways

Restricted access entrances work by preventing certain movements, often higher conflict left-turn maneuvers or through traffic between sideroads across an arterial. By limiting an entrance or driveway to right-in and right-out movements only, or restricting other movements, the reduced number of conflict points creates a more operationally efficient corridor with less anticipated crashes. Right-in / right-out entrances are most commonly established by use of non-traversable median or channelizing island in the entrance, such as those represented in Figure 3-3. These entrances can be spaced closer together and are subject to the Restricted Access Driveway Spacing requirements shown in the *Spacing of Driveways* section of this document. Restricted access driveways are an effective access management strategy that improves roadway safety and has less impact to vehicular operation when compared to a full access driveway at the same location. Restricted access entrances can also be used to mitigate conflicts in areas with limited or restricted sight distance.

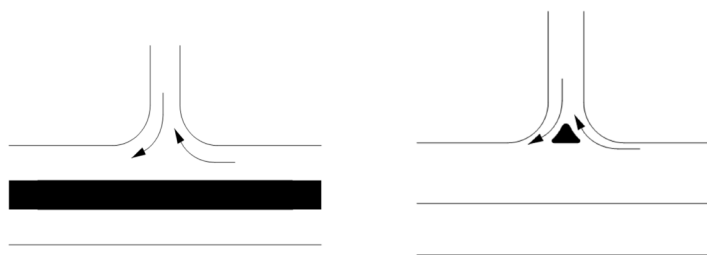

Figure 3-3: Restricted Access Driveways (Right in / Right Out)

Entrances or medians that restrict some, but not all left-turn or through movements are also classified as restricted access, such as those shown in Figure 3-4. These entrances and median openings may utilize the restricted access spacing requirements indicated in the *Spacing of Driveways* and *Spacing of*

Median Openings sections of this document. For private developers seeking a driveway permit, a Traffic Impact Study may be required to determine impacts to corridor and entrance operation to justify use of these entrance types. Refer to the manual section on *Traffic Impact Studies* for further guidance.

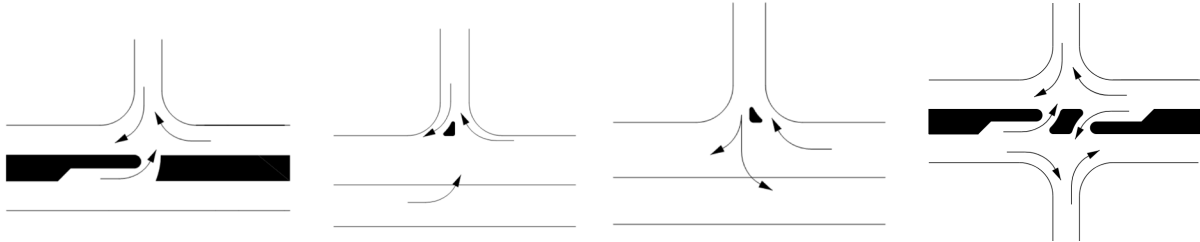

Figure 3-4: Restricted Access Driveway (Right In / Right Out / limited Left-Turns / J-Turns)

Access Spacing

An access connection is any driveway, public roadway / street, or other means of providing for the movement of vehicles and pedestrians to or from the public roadway system. Each access connection introduces conflicts and friction. This interaction increases the chance for crashes and reduces the operational efficiency of the roadway system. To address these issues, the following minimum access spacing standards have been established consistent with the intended function of the roadways. Access management spacing standards also involve compromise between engineering principles and the access needs of the surrounding land use. Each property is entitled to reasonable access, and as such it will not always be practical to provide the desirable access separation distances. When spacing requirements cannot be met, follow the guidance in the section on *Deviations from Access Manual Criteria* for the procedures that must be followed.

Separation of conflict areas has long been recognized as an effective way of improving vehicular safety, as well as pedestrian and bicycle safety. Table 3-2 shows that crashes can be expected to increase as access connections increase. For example, increasing the number of unsignalized access points from 30 per mile to 50 per mile would have an expected result of increasing the crash rate for the corridor by 33 percent.



Table 3-2: Relative Crash Rates for Unsignalized Access Spacing⁵

Unsignalized Access Points per Mile ^a	Average Spacing ^b (ft)	Relative Crash Rate
10	1,056	1.0
20	528	1.4
30	352	1.8
40	264	2.1
50	211	2.4
60	176	3.0
70	151	3.6

^a Total access connections on both sides of the roadway.

^b Average spacing between access connections on the same side of the roadway.

General Spacing Requirements

Access points have been classified as signalized intersections, unsignalized intersections, driveways, and median openings. Driveways and median openings have further been classified as full access or restricted access. The type and characteristic of the access point will impact its relationship to the corridor and requires different spacing considerations. While each access point is considered independently, many of these are directly related and dependent on each other. For example, a full access median opening is required at most signalized intersections, unsignalized intersections, or full access driveways. Figure 3-5 indicates where specific spacing criteria are to be used.

Refer to the section for *Full and Restricted Access Movements* for additional details on the classification of each.

⁵ TRB, Access Management Manual 2nd Edition (2014)

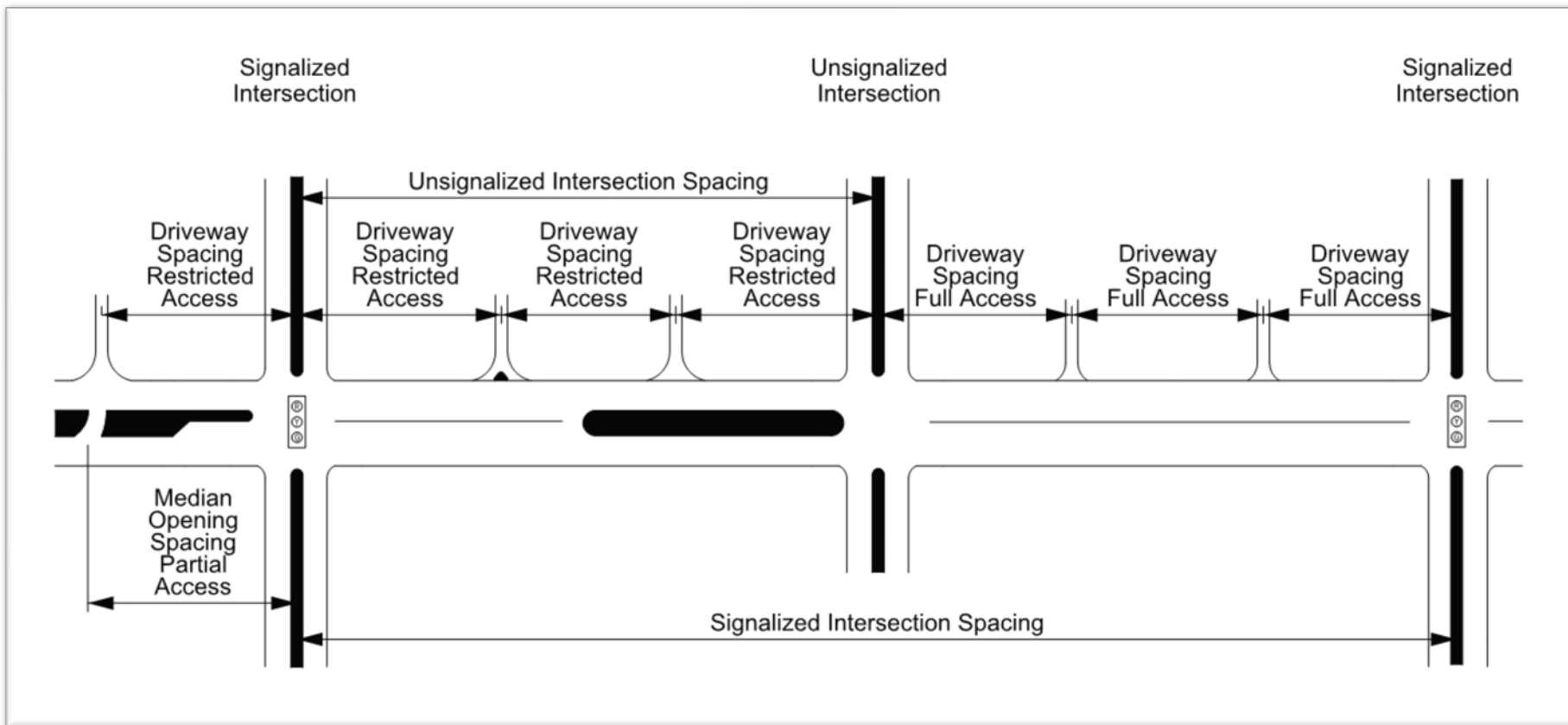

Figure 3-5: Typical Access Point Spacing

Spacing of Traffic Signals

Signalization of any access point along a corridor will have impacts to the function and progression speed of traffic. This guidance is applicable to all signalized access points, including intersections and driveways. Ideally, traffic signals should be uniformly spaced resulting in a system that when signalized, allows timing plans to efficiently accommodate two-way vehicular progression and encourage safe pedestrian crossing at reasonable intervals. Moreover, the actual spacing (distance) between traffic signals dictates the ability of the signal system to accommodate varying traffic conditions during peak and off-peak periods (different times of the day). Longer signalized intersection spacing provides more signal timing flexibility increasing the range of cycle lengths that can produce efficient traffic progression for different speeds. Closely spaced signalized intersections restrict signal timing flexibility and typically results in more frequent stops, unnecessary delay, and higher potential for crashes. See Table 3-3 for anticipated traffic progression speeds based on the distance between intersections and the signal cycle length.

Table 3-3: Progression Speed as a Function of Signal Spacing^{6, 7}

Cycle Length (s)	Progression Speed (MPH), by Signal Spacing			
	0.125 mile (660 ft.)	0.25 mile (1,320 ft.)	0.33 mile (1,760 ft.)	0.5 mile (2,640 ft.)
60	15	30	40	60
70	13	26	34	51
80	11	22	30	45
90	10	20	27	40
100	9	18	24	36
110	8	16	22	33
120	7.5	15	20	30

⁶ TRB, Access Management Manual 2nd Edition (2014)

⁷ UTK, Center for Transportation Research, Access Management Report (2017)

Spacing of Unsignalized Intersections

Unsignalized intersection spacing is referred to as the distance between two successive access connections identified as roads. Ideally, the spacing between unsignalized streets should complement those for signalized access connections, looking to preserve the ability of traffic progression and safe pedestrian access. Refer to Table 3-4 for required minimum spacing for an unsignalized intersection. When spacing requirements cannot be met, follow the guidance in the section on *Deviations from Access Manual Criteria* for the procedures that must be followed.

Table 3-4: Required Minimum Spacing of Unsignalized Intersections⁸

Intersections Spacing (Unsignalized) **					
Functional Classification of Road	Rural	Rural Town	Suburban	Urban	Urban Core
Freeway	N/A				
Principal Arterial	2,640 ft.	660 ft.	1,320 ft.	1,320 ft.	1,320 ft.
Minor Arterial	1,320 ft.	660 ft.	1,320 ft.	1,320 ft.	660 ft.
Major Collector	1,320 ft.	660 ft.	660 ft.	660 ft.	660 ft.
Minor Collector	330 ft.	330 ft.	660 ft.	660 ft.	330 ft.
Local Road or Street	*				

* Refer to Local zoning and ordinances for desired spacing, in lieu of additional guidance use 330 feet.

** Spacing to be measured from centerline to centerline of successive roads.

Spacing of Driveways

Intersections are a major control of the roadway system, so it is important to consider the placement and design of driveways, especially in proximity to intersections. Driveways close to an intersection create a situation where the road user must negotiate conflicts too close to an area that has been designed to manage large volumes of traffic and its own inherent conflicts. Proper driveway placement can also benefit the property owner by minimizing the time an intersection's traffic queue blocks ingress and egress to the owner's driveway. This may be especially beneficial for commercial properties.

Table 3-5 and Table 3-6 provide required minimum driveway spacing based on the functional and contextual classification of the corridor and the median type. If the property is located on a corner lot, the criteria in *Driveway Corner Clearance (C)* should also be reviewed. Each property is entitled to reasonable access. It is understood that limitations in property frontages or other constraints may not

⁸ UTK, Center for Transportation Research, Access Management Report (2017)

always make it practical to achieve the required minimum spacing for driveways. When spacing requirements cannot be met, follow the guidance in the section on *Deviations from Access Manual Criteria* for the procedures that must be followed. Application for a deviation will be required for all driveways except single-family residential, two-family residential, and field entrance driveways to justify and document not meeting the designated criteria. While single-family residential, two-family residential, and field entrance driveways do not require a formal application for deviation, every effort should be made to meet the driveway spacing criteria and the driveway spacing must still be reviewed and approved by the Regional TSMO Manager. On roadway design projects the Regional TSMO Manager review would occur as part of the standard TDOT review process. For private development projects, this would occur as part of the Traffic Impact Study or Highway Entrance Permit Request (see *Considerations for Private Development.*)

Double driveways typically serve commercial properties and have two one-way directional access points. Double driveways are considered a single driveway when applying the spacing criteria in Table 3-5 and Table 3-6. Spacing from these tables shall be applied and measurement from the centerline of the adjacent driveway to the centerline of whichever of the double driveways is closest. Refer to *Additional Commercial Driveway Requirements* for additional geometric requirements of Double Driveways.

Table 3-5: Required Minimum Spacing of Driveways (Urban, Urban Core & Suburban)

Driveway Spacing – (Urban, Urban Core & Suburban) ***									
Functional Classification	Suburban			Urban			Urban Core		
	Non-Traversable Median		Traversable Median	Non-Traversable Median		Traversable Median	Non-Traversable Median		Traversable Median
	Full Access	Restricted Access		Full Access	Restricted Access		Full Access	Restricted Access	
Freeway	N/A								
Principal Arterial*	1,320 ft.	330 ft.	880 ft.	880 ft.	330 ft.	880 ft.	880 ft.	330 ft.	660 ft.
Minor Arterial	660 ft.	330 ft.	660 ft.	660 ft.	330 ft.	660 ft.	440 ft.	330 ft.	330 ft.
Major Collector	660 ft.	330 ft.	330 ft.	660 ft.	330 ft.	330 ft.	440 ft.	330 ft.	330 ft.
Minor Collector	440 ft.	330 ft.	330 ft.	440 ft.	330 ft.	330 ft.	440 ft.	330 ft.	330 ft.
Local Road or Street	**								

* Direct driveway connections along Principal Arterials is discouraged whenever practical.

** Refer to Local zoning and ordinances for desired spacing, in lieu of additional guidance use 330 feet.

*** Spacing to be measured from the centerline of a driveway to the centerline of the next successive access point.

Table 3-6: Required Minimum Spacing of Driveways (Rural & Rural Town)

Driveway Spacing (Rural & Rural Town) ***						
Functional Classification	Rural			Rural Town		
	Non-Traversable Median		Traversable Median	Non-Traversable Median		Traversable Median
	Full Access	Restricted Access		Full Access	Restricted Access	
Freeway	N/A					
Principal Arterial*	1,320 ft.	660 ft.	880 ft.	880 ft.	330 ft.	660 ft.
Minor Arterial	880 ft.	660 ft.	880 ft.	440 ft.	330 ft.	660 ft.
Major Collector	880 ft.	660 ft.	660 ft.	440 ft.	330 ft.	330 ft.
Minor Collector	440 ft.	330 ft.	330 ft.	440 ft.	330 ft.	330 ft.
Local Road or Street	**					

* Direct driveway connections along Principal Arterials is discouraged whenever practical.

** Refer to Local zoning and ordinances for desired spacing, in lieu of additional guidance use 330 feet.

*** Spacing to be measured from the centerline of a driveway to the centerline of a successive access point.

Where possible, driveways should be located so that they are aligned with pre-existing median openings. When this is not possible, driveways should be located a minimum of 100 feet from the nearest full access or partial access median opening to minimize wrong-way movement and conflicts with traffic using the median opening as shown in Figure 3-6.

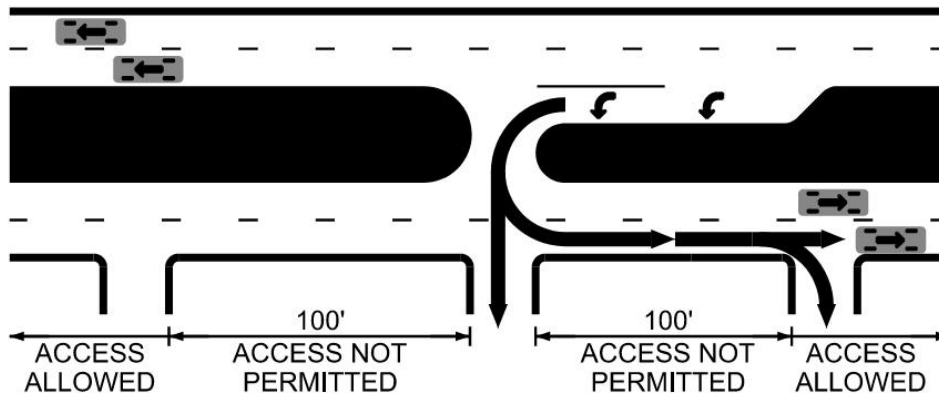

Figure 3-6: Driveway Spacing Upstream of Median Opening (Partial and Full Access)

Number of Entrances per Property

Generally, the number of entrances to a single property shall be kept to the minimum necessary to provide adequate and reasonable service without compromising safety. Additionally, all driveways will be subject to the required minimum spacing in Table 3-5 and Table 3-6. For single-family residential properties, only one driveway shall be allowed unless the frontage is 330 feet or greater, then a second driveway may be allowed. For all other uses, please consult the following:

- Typically, only one entrance shall be permitted.
- For frontages of 330 feet to 660 feet, an additional entrance may be permitted based on need. Private developers should be required to justify need with a Traffic Impact Study. Refer to the manual section on *Traffic Impact Studies* for additional guidance.
- For frontages in excess of 660 feet, more than two entrances may be permitted. Private developers should be required to justify need with a Traffic Impact Study. The additional entrances will still be subject to minimum spacing requirements for driveways.
- Where corner lots are involved, the regulations described above shall apply separately to each roadway. Driveways will typically be preferred on the lower classified roadway of a corner lot.
- Double driveways typically serve commercial properties and have two one-way directions. Double driveways are considered a single driveway when applying the spacing criteria in Table 3-5 and Table 3-6. Spacing from these tables shall be applied and measurement from the centerline of the adjacent driveway to the centerline of whichever of the double driveways is

closest. Refer to *Additional Commercial Driveway Requirements* for additional geometric requirements of Double Driveways.

For private developers, a deviation from the criteria for the number of entrances may be applied for if the need is justified in a Traffic Impact Study. The Traffic Impact Study must show that the adverse impacts of additional driveways will be outweighed by the improvement of circulation and safety. Refer to manual section on *Traffic Impact Studies* for additional guidance.

Access Spacing – Opposite Side of the Roadway

An access connection is any driveway, public road, or other means of providing for the movement of vehicles and pedestrians to or from the public roadway system. Access connections on opposite sides of a roadway present specific access location and management issues. These connections should be directly across from each other with their centerlines aligned. Closely spaced offset connections on opposite sides of an undivided roadway or on a roadway with a Two-Way Left-Turn Lane (TWLTL) result in adverse jog maneuvers, as demonstrated in Figure 3-7. Distinct and separate turning movements, as shown in Figure 3-8 are preferred to jog maneuvers.

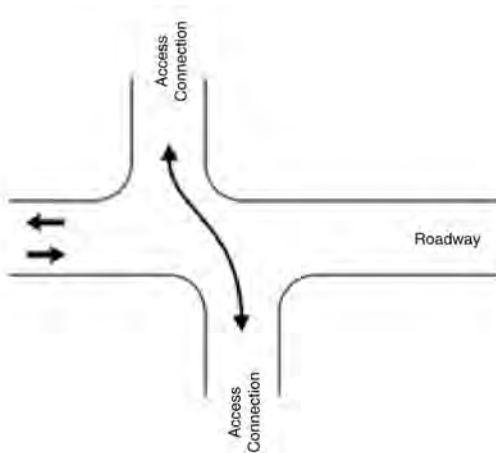

Figure 3-7: Adverse Jog Maneuver^{9, 10}

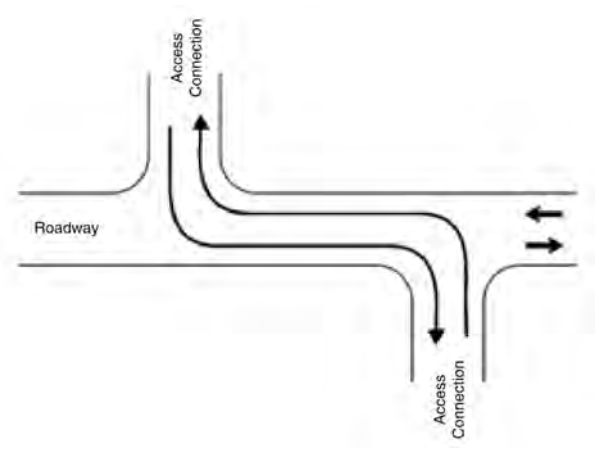

Figure 3-8: Distinct Turning Movements^{9, 10}

Additionally, closely spaced access connections can lead to unwanted conflicting left-turning movements, as shown in Figure 3-9. Figure 3-10 demonstrates the potential for overlapping left-turn movements, also known as left-turn lockup, when a two-way left-turn lane is present. An access

⁹ UTK, Center for Transportation Research, Access Management Report (2017) ¹⁰ TRB, Access Management Manual 2nd Edition (2014)

connection should be configured to avoid the potential for left-turn lockup or any conflicting left-turn movements as shown in Figure 3-11.

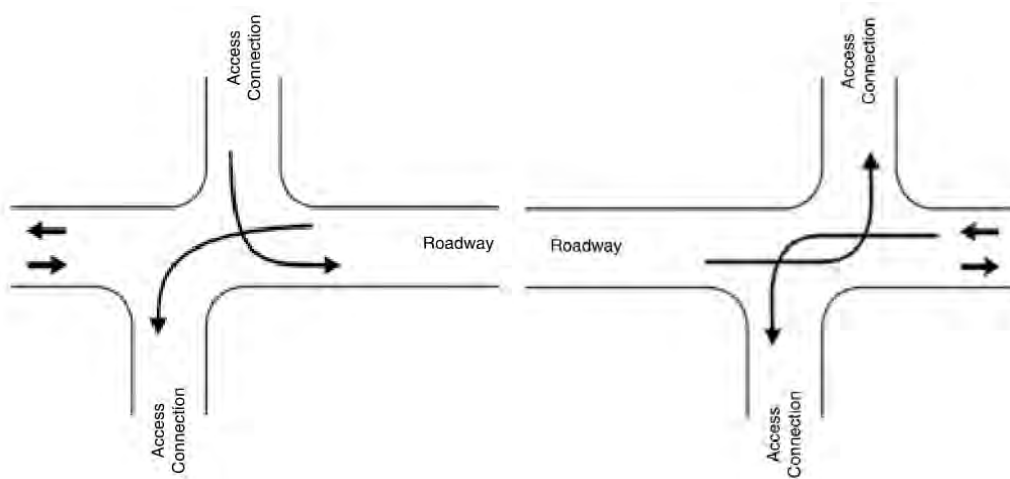

Figure 3-9: Conflicting Left-Turn movements.^{11, 12}

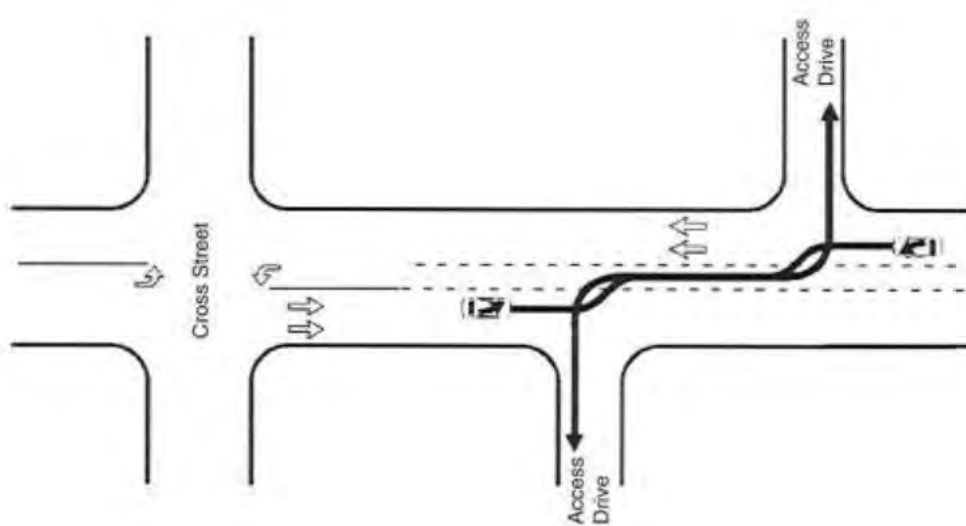

Figure 3-10: Overlapping Left-Turn Movements with Two-Way Left-Turn Lane^{11, 12}

¹¹ UTK, Center for Transportation Research, Access Management Report (2017)

¹² TRB, Access Management Manual 2nd Edition (2014)

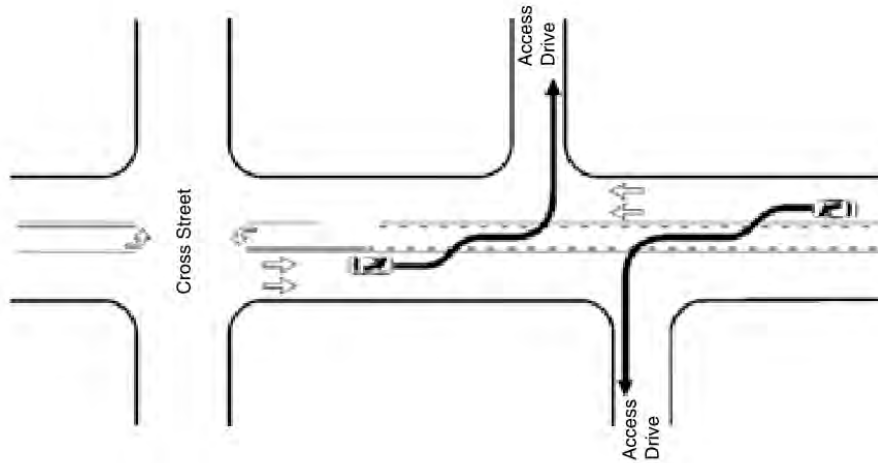

Figure 3-11: Access Configuration to Avoid Overlapping Left-Turn Movements^{13, 14}

When offset access connections are required on opposite sides of the road, Table 3-7 provides required minimum spacing. Offset is measured from centerline-to-centerline of each access connection as shown in Figure 3-12. When spacing requirements cannot be met, follow the guidance in the section on *Deviations from Access Manual Criteria* for the procedures that must be followed.

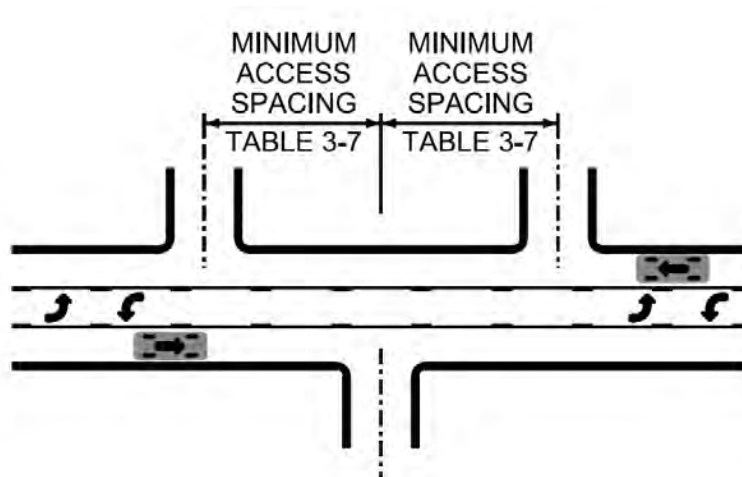

Figure 3-12: Minimum Spacing of Offset Access Points

¹³ UTK, Center for Transportation Research, Access Management Report (2017)

¹⁴ TRB, Access Management Manual 2nd Edition (2014)

Table 3-7: Required Minimum Spacing of Offset Access Points¹⁵

Minimum Spacing of Driveway on Opposite Sides of a Roadway **					
Functional Classification of Road	Rural	Rural Town	Suburban	Urban	Urban Core
Freeway	N/A				
Principal Arterial	880 ft.	330 ft.	880 ft.	330 ft.	330 ft.
Minor Arterial	880 ft.	330 ft.	660 ft.	330 ft.	330 ft.
Major Collector	660 ft.	175 ft.	330 ft.	175 ft.	175 ft.
Minor Collector	330 ft.	175 ft.	330 ft.	175 ft.	175 ft.
Local Road or Street	*				

* Refer to local zoning and ordinances for desired spacing, in lieu of additional guidance use 175 feet.

** Spacing to be measured from the centerline of one access point to the centerline of the access point on the opposite side of the road

Spacing of Median Openings

Median opening spacing is dependent on the type of median (restricted vs. full access, see *Full and Restricted Access Movements* for descriptions) and the roadway's functional and context classifications. Minimum median opening spacing requirements help to reduce operational impacts and safety problems that arise from closely spaced connections. Table 3-8 provides minimum spacing for both full access and restricted access median openings that shall be met. When spacing requirements cannot be met, follow the guidance in the section on *Deviations from Access Manual Criteria* for the procedures that must be followed.

¹⁵ Developed with recommendations from UTK, Center for Transportation Research, Access Management Report (2017) and minimum spacing of driveways at traversable median openings.

Table 3-8: Required Minimum Spacing of Median Openings

Median Opening Spacing **										
Functional Classification	Rural		Rural Town		Suburban		Urban		Urban Core	
	Full Access	Restricted Access	Full Access	Restricted Access	Full Access	Restricted Access	Full Access	Restricted Access	Full Access	Restricted Access
Freeway	N/A									
Principal Arterial	1,320 ft.	660 ft.	880 ft.	330 ft.	1,320 ft.	330 ft.	880 ft.	330 ft.	880 ft.	330 ft.
Minor Arterial	880 ft.	660 ft.	440 ft.	330 ft.	660 ft.	330 ft.	660 ft.	330 ft.	440 ft.	330 ft.
Major Collector	880 ft.	660 ft.	440 ft.	330 ft.	660 ft.	330 ft.	660 ft.	330 ft.	440 ft.	330 ft.
Minor Collector	440 ft.	330 ft.	440 ft.	330 ft.	440 ft.	330 ft.	440 ft.	330 ft.	330 ft.	330 ft.
Local Road or Street	*									

* Refer to Local zoning and ordinances for desired spacing, in lieu of additional guidance use 330 feet.

** Spacing to be measured from centerline to centerline of successive median openings.

Spacing near Interchange Ramps

Spacing near Signalized Interchange Ramp Terminals

The operation of a signalized ramp terminal intersection is essentially the same as that of other signalized roadway intersections. See Figure 3-13 and Table 3-9 for required minimum spacing for two-lane and four-lane cross roads adjacent to a signalized interchange ramp. All spacing to be measured from centerline to centerline of the applicable access points.

Spacing near Free-Flow Interchange Ramp Terminals

On a free-flow ramp terminal, traffic on the crossroad does not stop for the ramp traffic. The ramp traffic must merge and weave with the through traffic. See Figure 3-14 and Table 3-10 for required minimum spacing for two-lane and four-lane cross roads adjacent to a free-flow ramp terminal. All spacing to be measured from the beginning or end of ramp taper to the centerline of the applicable access points.

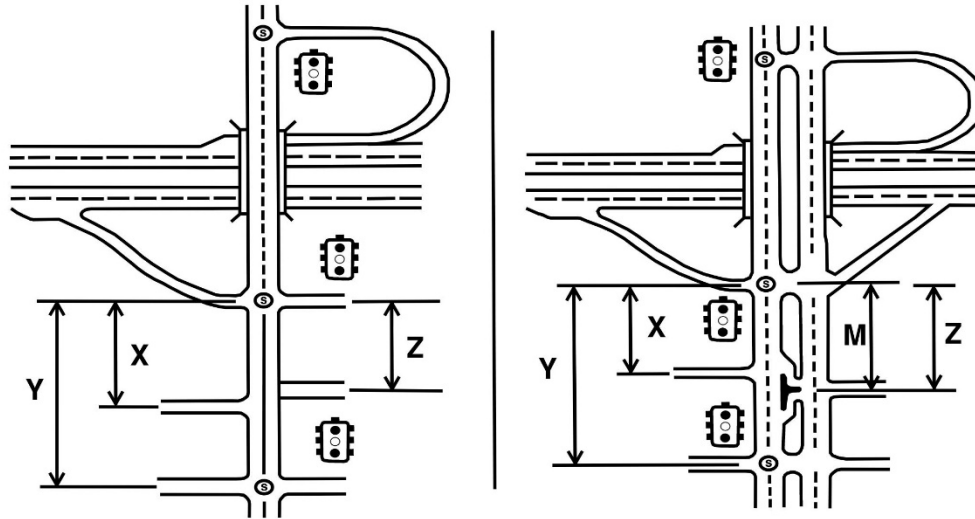

Figure 3-13: Access Spacing at Signalized Interchange Ramp Terminals^{16, 17}

Table 3-9: Required Minimum Access Spacing at Signalized Interchange Ramp Terminals^{16, 17}

Spacing Requirements at Signalized Interchange Ramps				
Arterial Width (no. of Lanes)	Spacing Dimension			
	X	Y	Z	M
Urban Area (35 mph)				
2	590 ft.	1,320 ft.	660 ft.	-
4	590 ft.	1,320 ft.	750 ft.	660 ft.
Suburban Area (45 mph)				
2	590 ft.	1,320 ft.	660 ft.	-
4	590 ft.	1,320 ft.	800 ft.	660 ft.
Rural Area (55 mph)				
2	535 ft.	1,320 ft.	560 ft.	-
4	535 ft.	2,640 ft.	865 ft.	550 ft.

X - Distance from ramp terminal to first restricted access driveway.
Y - Distance to first major intersection from end of ramp terminal.
Z - Distance from last driveway to the start of freeway entrance ramp.
M - Distance to first directional restricted access median opening after the exit ramp or before the entrance ramp.

¹⁶ UTK, Center for Transportation Research, Access Management Report (2017)

¹⁷ TRB, Access Management Manual 2nd Edition (2014)

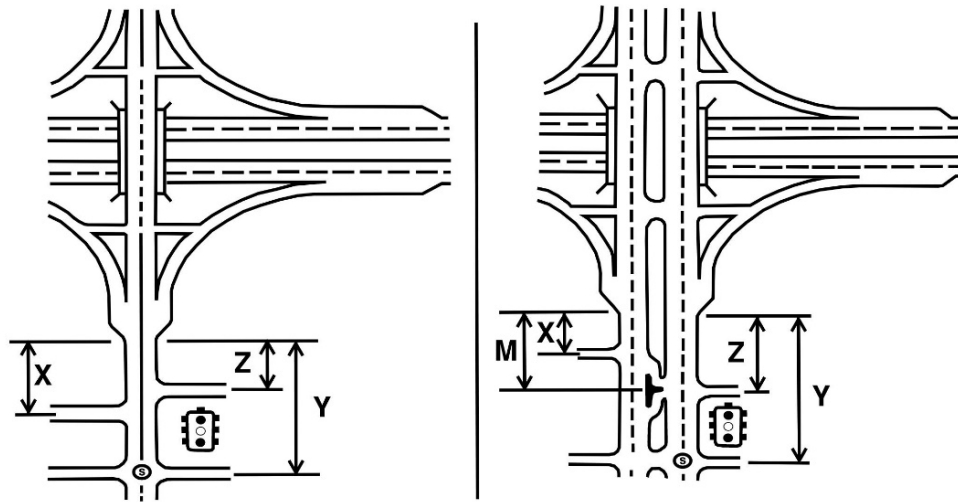

Figure 3-14: Access Spacing at Free-Flow Interchange Ramp Terminals^{18, 19}

Table 3-10: Required Minimum Access Spacing at Free-Flow Interchange Ramp Terminals^{18, 19}

Spacing Requirements at Free-Flow Interchange Ramps				
Arterial Width (no. of Lanes)	Spacing Dimension			
	X	Y	Z	M
Urban Area (35mph)				
2	590 ft.	1,320 ft.	1,100 ft.	-
4	590 ft.	1,320 ft.	1,100 ft.	660 ft.
Suburban Area (45 mph)				
2	590 ft.	1,320 ft.	1,100 ft.	-
4	590 ft.	1,320 ft.	1,100 ft.	660 ft.
Rural Area (55 mph)				
2	535 ft.	1,320 ft.	800 ft.	-
4	535 ft.	2,640 ft.	800 ft.	550 ft.

X - Distance from ramp terminal to first restricted access driveway.
Y - Distance to first major intersection from end of ramp terminal.
Z - Distance from last driveway to the start of freeway entrance ramp.
M - Distance to first directional restricted access median opening after the exit ramp or before the entrance ramp.

¹⁸ UTK, Center for Transportation Research, Access Management Report (2017)

¹⁹ TRB, Access Management Manual 2nd Edition (2014)

When the criteria shown cannot be met, follow the guidance in the section on *Deviations from Access Manual Criteria* for the procedures that must be followed. When a deviation is required, as an absolute minimum, driveways along a rural corridor shall be 300 feet from the ramp terminal, treating each side of the crossroad independently. Similarly, for Urban, Urban-core, Suburban, and Rural Town roadways, driveways shall be an absolute minimum of 100 feet from the ramp terminal.

Access Geometrics

Access design criteria is an important component of access management as they help to preserve the public investment by limiting the conflict points and the interference between through and turning vehicles. Improper access design elements can negatively impact the traffic flow at intersections. Providing proper access design helps:

- Improve safety by providing adequate sight distance at intersections;
- Reduce the speed difference between through traffic and turning vehicles;
- Minimize the number of conflict points at an intersection;
- Provide adequate storage for turning vehicles;
- Facilitate the entry and exit of vehicles at a driveway; and
- Improve accessibility and safety for non-motorized users.

Intersection Geometrics

Intersection Design Vehicle

Designers should consider the largest design vehicle that is likely to frequently use the intersection or access point. For guidance on design vehicle selection, refer to The Tennessee Department of Transportation (TDOT) *Design Guidelines Chapter 2-200.05*. *TDOT Design Guidelines Chapter 3-802.00 Multi-Modal Design* provides additional guidance on design vehicle selection and considerations for accommodating larger vehicles that are infrequent users of a facility (identified as control vehicles).

Turning Lanes

Turning lanes (left or right) improve traffic operations by increasing intersection capacity and decreasing delay. A turning vehicle must decrease speed to make a turn safely. If a turn lane is absent, drivers of through vehicles who are following the turning vehicle may also need to decelerate to a very slow speed or stop completely. The deceleration within the travel lane can cause conflicts, reduce safety and capacity, and increase delay.

Turn lane warrants are volume-based guidance to help designers decided if an exclusive turn lane is appropriate at a given access point. The decision to include or exclude an exclusive turn lane should not be based on these warrants alone and should be made in the context of the surrounding area. Many factors should be considered, such as:

- Speeds
- Traffic volumes
- Percentage of trucks
- Capacity
- Type of roadway
- Effects on pedestrians and bicyclists
- Availability of right-of-way
- Service provided
- The arrangement and frequency of intersections
- Available sight distance
- Presence of median opening

Left-Turn Lanes

A left-turn lane is a separate, full-width lane provided for vehicles that are making a left turn from a roadway. These lanes eliminate delay to vehicles in the adjacent through lane, which otherwise would have to stop behind the vehicle that was waiting to turn. Left-turn lanes also enhance vehicular safety by providing left-turning vehicles with a safe area in which to decelerate, to stop if necessary, and then to make the turn. In addition to the warrants below, refer to the section on [Left Turn Lanes in Medians](#) for additional guidance.

Left-Turn Lane Warrants – Unsignalized Intersections

Left-turn lanes are an effective way of mitigating the speed differential between a left-turning vehicle and the following through vehicle. The AASHTO Green Book 7th Edition, Section 9.7.3 provides volume-based warrants and guidelines for left-turn lanes at unsignalized intersections. The AASHTO warrants are replicated in Figure 3-15, Figure 3-16, and Figure 3-17. These figures are applicable at unsignalized intersections with roads and driveways where the major road is uncontrolled and the minor road approaches are stop or yield controlled. The volume-based warrants that follow indicate situations where a left-turn lane would help mitigate traffic conflicts, not necessarily situations where a left-turn lane is required or must be constructed.

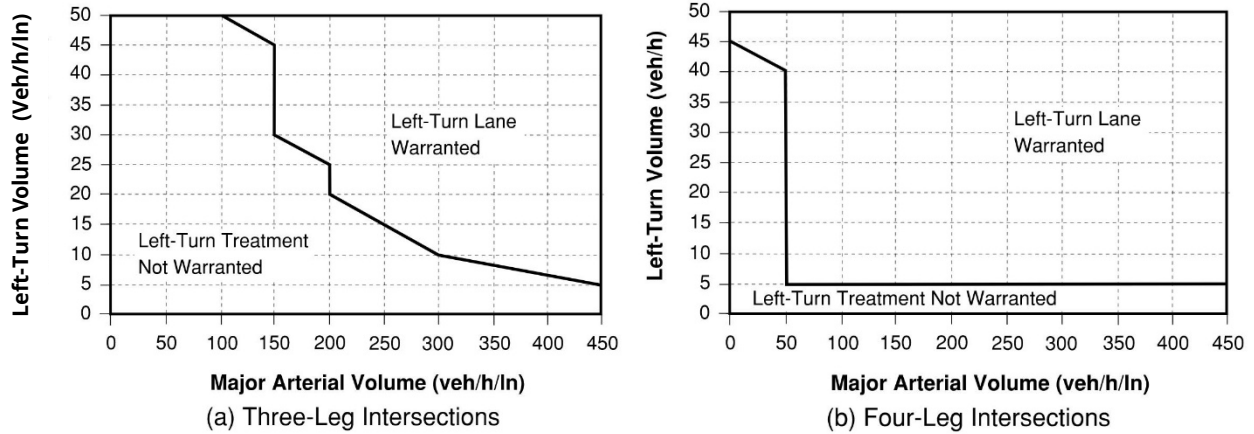

Figure 3-15: Left-Turn Lane Warrant for Urban and Suburban Arterials (Unsignalized)^{20, 21}

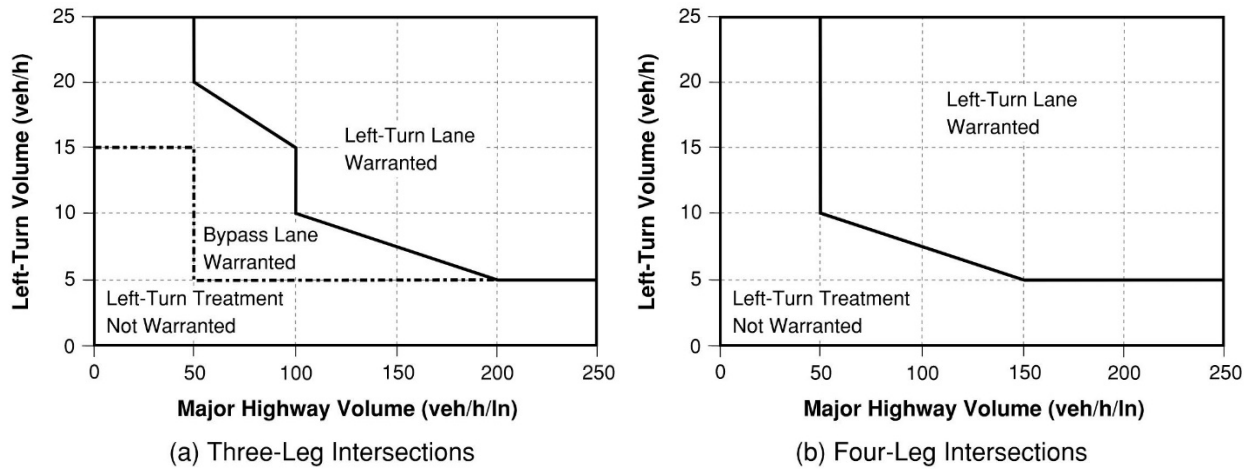

Figure 3-16: Left-Turn Lane Warrant for Two-Lane Rural Roadways (Unsignalized)^{20, 21}

²⁰ TRB, NCHRP Report 745, Left-Turn Accommodations at Unsignalized Intersections (2013)

²¹ AASHTO, A Policy on Geometric Design of Highways and Streets 7th Edition (2018)

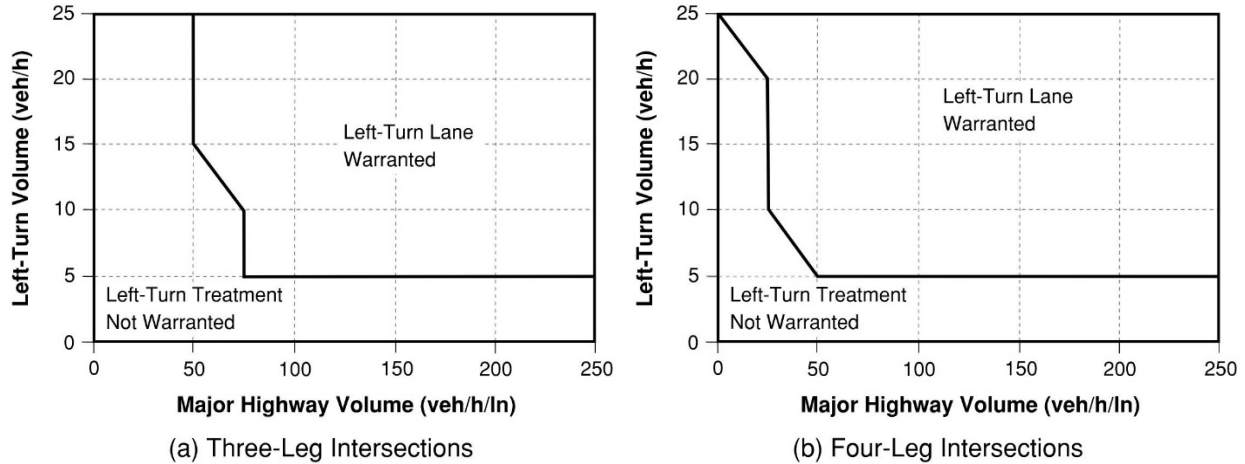

Figure 3-17: Left-Turn Lane Warrant for Four-Lane Rural Roadways (Unsignalized)^{22, 23}

Left-Turn Lane Warrants –Signalized Intersections

Exclusive left-turn lanes at a signalized intersections should be installed where exclusive left-turn signal phasing is required. Refer to the *TDOT Traffic Design Manual, Chapter 43.1* for current policies for the need for left-turn phasing at a signalized intersection. Exclusive left-turn lanes at signalized intersections should be considered where left-turn volumes exceed 100 vehicles per hour (veh/h). Left-turn lanes may be provided for lower volumes as well based on the assessment of need or additional traffic analysis. Consider impacts to pedestrian crossings when analyzing turn lane benefits for these lower volume cases. When left-turn volumes exceed 300 veh/h, a dual left-turn lane should be considered. A capacity analysis will help determine the benefits of an additional lane.

On the minor road approaching an intersection where a signal is either existing or proposed, a minimum of two egress lanes from the minor road should be considered. This will help improve operations and efficiency of the minor road, even in locations where a left-turn lane may not be warranted.

²² TRB, NCHRP Report 745, Left-Turn Accommodations at Unsignalized Intersections (2013)

²³ AASHTO, A Policy on Geometric Design of Highways and Streets 7th Edition (2018)

Right-Turn Lane

A right-turn lane is a separate, full-width lane provided for vehicles that are making a right turn from a roadway. These lanes eliminate delay to vehicles in the adjacent through lane that would otherwise have to slow, or perhaps stop, behind a vehicle that is waiting to turn. Right-turn lanes enhance vehicle safety by providing right-turning vehicles with a safe area to decelerate, to stop if necessary, and to make the turn. It is understood that site constraints like limited right-of-way, bicyclist and pedestrian considerations, business impacts and other disadvantages should be considered when considering exclusive right-turn lanes for an intersection.

Right-Turn Lane Warrants – Unsignalized Intersections

Adding a right-turn lane to the major road of a two-way stop-controlled intersection can significantly improve operations and safety for vehicles at an intersection. Figure 3-18 and Figure 3-19 provide right-turn lane warrants at unsignalized intersections with two-way stop control along the minor road and free flow traffic along the major road. Based on the design speed and volumes of the major roadway, any conditions that are to the right (above the designed graph line in Figure 3-18 and Figure 3-19) warrants consideration of a right-turn lane. When speeds are less than 40 miles per hour (mph), a right turning volume of 300 veh/h should be used to warrant the need for a right-turn lane. The volume-based warrants indicate situations where a right-turn lane would help to mitigate traffic conflicts, not necessarily situations where a right-turn lane is required or must be constructed. Right-turn lanes can have an adverse safety and operational effect for pedestrians and bicyclists. All existing and future users of the roadway should be considered when determining turn lane needs.

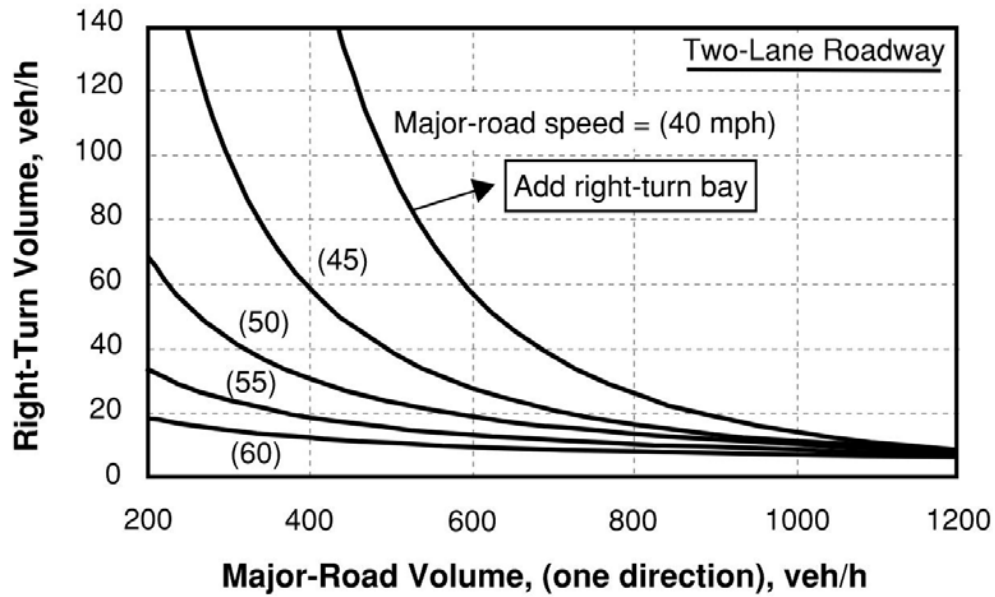

Figure 3-18: Right-Turn Lane Warrant along Two-Lane Roadway (Unsignalized Intersection with Two-Way Stop-Control)²⁴

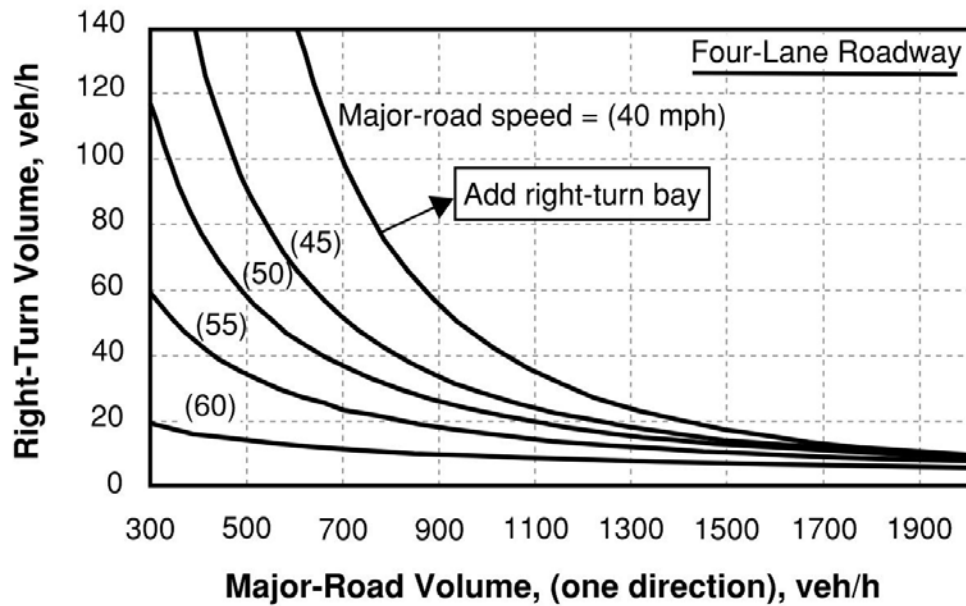

Figure 3-19: Right-Turn Lane Warrant along Four-Lane Roadway (Unsignalized Intersection with Two-Way Stop-Control)²⁵

²⁴ TRB, NCHRP 457, Evaluating Intersection Improvements (2001)

²⁵ TRB, NCHRP 457, Evaluating Intersection Improvements (2001)

Right-Turn Lane Warrants – Signalized Intersections

Exclusive right-turn lanes should be considered when the right-turn volume exceeds 300 veh/h and the adjacent through-lane volume also exceeds 300 vehicles per hour per lane²⁶. A capacity analysis for the intersection will also provide a measure of the benefits of a right-turn lane to the overall intersection operation.

Decelerations and Storage Lengths

The physical length of a turn lane is comprised of the turn lane bay taper and the full width turn lane. The total physical length of the exclusive turn lane should be the sum of the length for lane change, deceleration, and storage distances. Figure 3-20 shows where each of these distances are measured for a turn lane. Guidance on bay taper length requirements can be found under the following section on *Turn Lane Taper Rates*. Refer to AASHTO Green Book, 7th Edition, Section 9.7.2 for additional guidance on the design of turn-lanes and turn-lane tapers.

The lane change and deceleration distance, shall be calculated using the design speed of the through movement and assigned using a distance from Table 3-11. When it is not practical to accommodate the full length, designers may assume some deceleration prior to the lane change. A speed of ten mph less than the design speed may be utilized in constrained conditions when selecting the lane change and deceleration distance.

The minimum required queue storage length for unsignalized left-turn lanes is shown in Table 3-12. When trucks are anticipated to be greater than two percent of the traffic in the turn lane refer to The AASHTO Green Book, 7th Edition, Section 9.7.2.2 for additional guidance to account for larger vehicle sizes. Queue storage length for right turning vehicles at unsignalized intersections shall be based on engineering judgement. Queue storage lengths for both right- and left-turn lanes should be a minimum of 50 feet on urban core, urban, suburban, and rural town roads, and 100 feet on rural roads.

For signalized intersections, storage lengths are a function of signal timing, volumes, and saturation flow rates. For TDOT roadway design projects, the required storage lengths will be provided by TDOT Region Traffic Design Office during Stage 1 Context and Scoping phase (PDN Process) of the project development. . For private development projects, traffic analysis that includes required storage lengths will be part of the Traffic Impact Study. When a conceptual report nor a Traffic Impact Study

²⁶ TRB, Highway Capacity Manual (2016), Pages 19-33,

are available, assistance in determining storage lengths can be provided by the TDOT Region Traffic Operation Office.

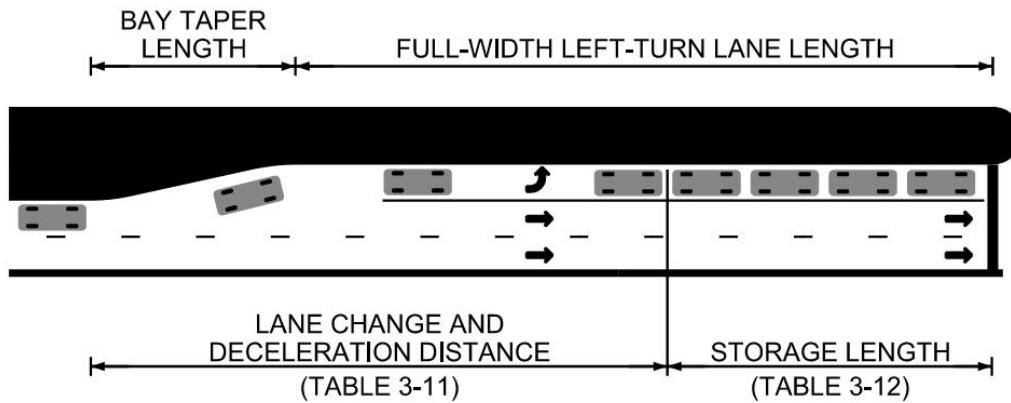

Figure 3-20: Functional Area, for an Exclusive Turn Lane.²⁷

Table 3-11: Lane Change and Deceleration Distance²⁷

Speed (MPH)	Lane Change and Deceleration Distance (ft)
20	70
25	105
30	150
35	205
40	265
45	340
50	415
55	505
60	600
65	700
70	815

Table 3-12: Queue Storage Length for Exclusive Left-Turn Lanes at Unsignalized Intersections²⁷

Left-Turn Volume (veh/h)	Storage Length (ft)				
	Opposing Volume (veh/h)				
	200	400	600	800	1,000
40	50	50	50	50	50
60	50	50	50	50	50
80	50	50	50	50	75
100	50	50	50	75	75
120	50	50	75	75	100
140	50	50	75	100	125
160	50	75	75	100	150
180	50	75	75	125	150
200	50	75	100	125	200
220	75	75	100	150	225
240	75	75	125	150	275
260	75	100	125	175	325
280	75	100	125	200	400
300	75	100	150	225	525

²⁷ AASHTO, A Policy on Geometric Design of Highways and Streets 7th Edition, (2018)

Turn Lane Taper Rates

When median width is insufficient for inclusion of a left-turn lane, travel lanes approaching and departing from the cross street will need to be transitioned to create space for the turn lane at the intersection. Use the following equations and guidelines for acceptable minimum taper rates at these locations (reference Figure 3-21).

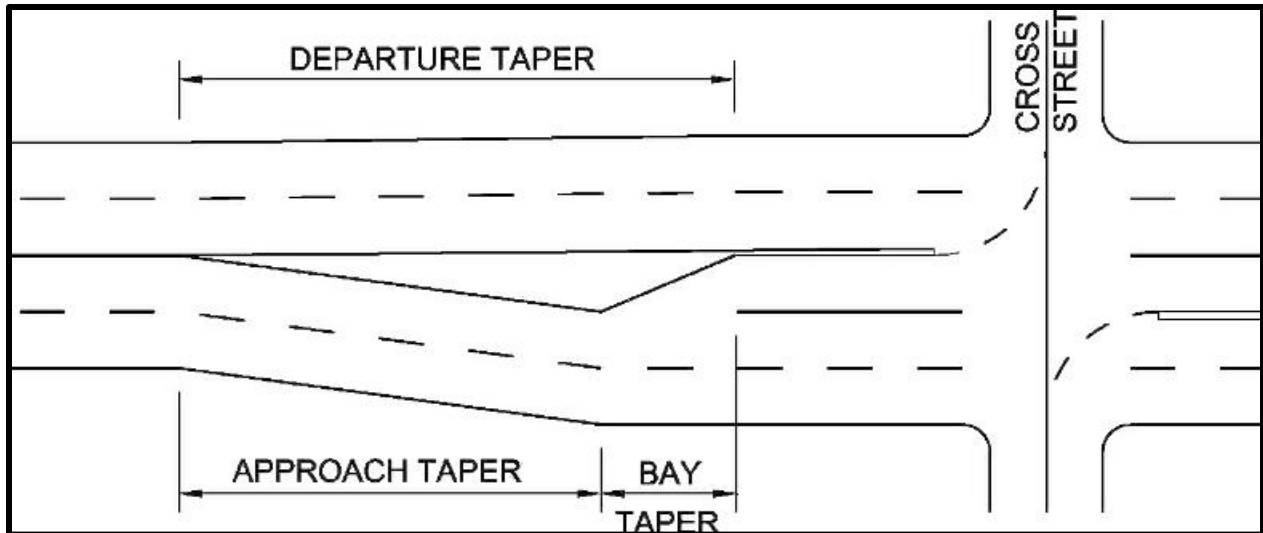

Figure 3-21: Turning Lane Taper Terminology

1) APPROACH TAPER

a) $L = W \times S$, Speed ≥ 45 mph

b) $L = \frac{WS^2}{60}$, Speed < 45 mph

Where L = Length of Taper in feet

W = Width of Offset in feet

S = Design Speed in miles per hour

2) BAY TAPER

$$L = \frac{WS}{3}, \text{ L, W, S as defined for approach taper above.}$$

8:1 (Length : Width) Minimum Taper Rate for low speeds.

15:1 (Length : Width) Maximum Taper rate for higher speeds.

3) DEPARTURE TAPER

The departure taper begins at the end of the bay taper and ends at the beginning of the approach taper and cannot exceed the approach taper rate criteria.

Lane Drop After Intersections

Existing two-lane highways are often widened to a multi-lane section at intersections to provide additional capacity (especially at signalized locations). When this occurs, the lane may be dropped at the intersection at a cross road or may carry through and transition after the intersection.

In order to address the resulting lane drop situation, follow the schematic shown in Figure 3-22, which shows the minimum length for the additional through lanes required to adequately sign the lane drop and minimize lane changing within the intersection. Use Table 3-13, to help find the “d” value reflected in Figure 3-22. An example for computing the required transition lengths is also included with this figure.

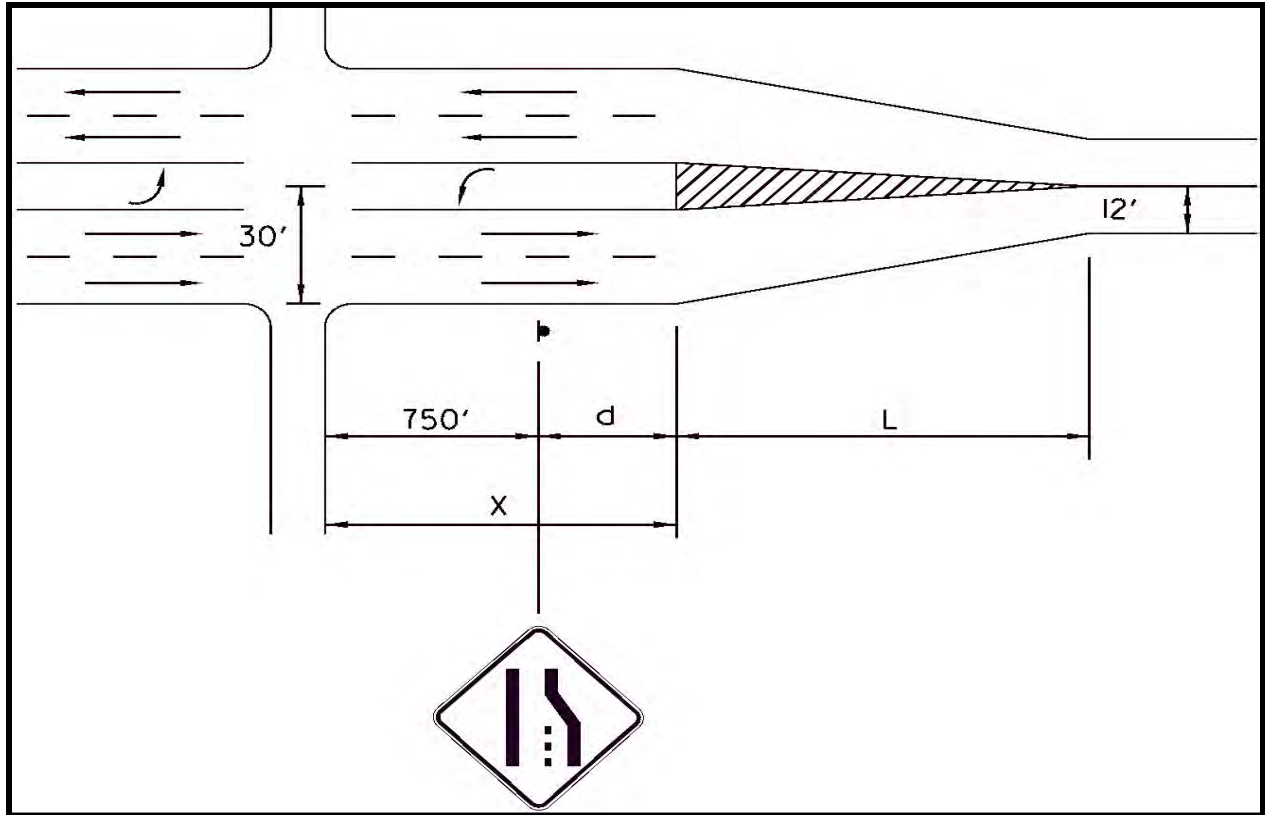

Figure 3-22 Minimum Length (X) for Lane Extensions through an Intersection Width

$$L = (S^2 \times W)/60 \text{ (for speed less than 45 mph)}$$

$$L = S \times W \text{ (for speed 45 mph or more)}$$

750 ft = Minimum distance at which sign is not visible to traffic approaching intersection (in order to minimize lane changing within intersection).

d = As required by the Manual on Uniform Traffic Control Devices (*M.U.T.C.D.*) 11th edition, Sec. 2C.04, Table 2C-3, Condition A. See Table 3-13.

L = Transition length, as required by *M.U.T.C.D.* 11th edition, Sec. 3B.12, Fig. 3B-14.

Note 1 Terminating the outside lane as a right-turn lane at an intersection may be considered subject to the review and approval of the TDOT Region Traffic Design office for TDOT projects, and the TDOT Traffic Operations office for private development.

Note 2 See *M.U.T.C.D.*, 11th edition Section 2C.47 for guidance, options, and standard use of Lane Ends Signs.

To find “d” use the following table:

Table 3-13: Guidelines for Advance Placement of Warning Signs²⁸

Advance Placement Distance ¹									
Posted or 85th Percentile Speed	Condition A: Speed reduction and lane changing in heavy traffic ²	Condition B: Deceleration to the listed Advisory Speed (mph) for the Condition							
		0 ³	10 ⁴	20 ⁴	30 ⁴	40 ⁴	50 ⁴	60 ⁴	70 ⁴
20 mph	225 ft	100 ft ⁶	N/A ⁵	-	-	-	-	-	-
25 mph	325 ft	100 ft ⁶	N/A ⁵	N/A ⁵	-	-	-	-	-
30 mph	460 ft	100 ft ⁶	N/A ⁵	N/A ⁵	-	-	-	-	-
35 mph	565 ft	100 ft ⁶	N/A ⁵	N/A ⁵	N/A ⁵	-	-	-	-
40 mph	670 ft	125 ft	100 ft ⁶	100 ft ⁶	N/A ⁵	-	-	-	-
45 mph	775 ft	175 ft	125 ft	100 ft ⁶	100 ft ⁶	N/A ⁵	-	-	-
50 mph	885 ft	250 ft	200 ft	175 ft	125 ft	100 ft ⁶	-	-	-
55 mph	990 ft	325 ft	275 ft	225 ft	200 ft	125 ft	N/A ⁵	-	-
60 mph	1,100 ft	400 ft	350 ft	325 ft	275 ft	200 ft	100 ft ⁶	-	-
65 mph	1,200 ft	475 ft	450 ft	400 ft	350 ft	275 ft	200 ft	100 ft ⁶	-
70 mph	1,250 ft	550 ft	525 ft	500 ft	450 ft	375 ft	275 ft	150 ft	-
75 mph	1,350 ft	650 ft	625 ft	600 ft	550 ft	475 ft	375 ft	250 ft	100 ft ⁶

Notes:

¹The distances are adjusted for a sign legibility distance of 180 ft for Condition A. The distances for Condition B have been adjusted for a sign legibility distance of 250 feet, which is appropriate for an alignment warning symbol sign.

For Conditions A and B, warning signs with less than 6-inch legend or more than four words, a minimum of 100 feet should be added to the advance placement distance to provide adequate legibility of the warning sign.

²Typical conditions are locations where the road user must use extra time to adjust speed and change lanes in heavy traffic because of a complex driving situation. Typical signs are Merge and Right Lane Ends. The distances are determined by providing the driver a PRT of 14.0 to 14.5 seconds for vehicle maneuvers (2005 AASHTO Policy, Exhibit 3-3, Decision Sight Distance, Avoidance Maneuver E) minus the legibility distance of 180 feet for the appropriate sign.

³Typical condition is the warning of a potential stop situation. Typical signs are Stop Ahead, Yield Ahead, Signal Ahead, and Intersection Warning signs. The distances are based on the 2005 AASHTO Policy, Exhibit 3-1, Stopping Sight Distance, providing a PRT of 2.5 seconds, a deceleration rate of 11.2 feet/second², minus the sign legibility distance of 180 feet.

²⁸ M.U.T.C.D. 2023 Manual (Table 2C-3 of Section 2C.04)

⁴Typical conditions are locations where the road user must decrease speed to maneuver through the warned condition. Typical signs are Turn, Curve, Reverse Turn, or Reverse Curve. The distance is determined by providing a 2.5 second PRT, a vehicle deceleration rate of 10 feet/second², minus the sign legibility distance of 250 ft.

⁵No suggested distances are provided for these speeds, as the placement location is dependent on site conditions and other signing. An alignment warning sign may be placed anywhere from the point of curvature up to 100 feet in advance of the curve. However, the alignment warning sign should be installed in advance of the curve and at least 100 feet from any other signs.

⁶The minimum advance placement distance is listed as 100 feet to provide adequate spacing between signs.

EXAMPLE:

For Condition A: Speed Reduction and Lane Changing in Heavy Traffic:

Posted speed = 55 mph

$$X = 750 \text{ feet} + d = 750 \text{ feet} + 990 \text{ feet} = 1,740 \text{ feet}$$

$$L = S \times W \text{ (for speed 45 mph or more)} = 55 \times 18 = 990 \text{ feet}$$

Where:

S = Posted speed (55 mph)

W= Transition Width (30 feet – 12 feet = 18 feet)

For Condition B: Deceleration from Posted speed of 55mph to speed of 30 mph:

$$X = 750 \text{ feet} + d = 750 \text{ feet} + 200 \text{ feet} = 950 \text{ feet}$$

$$L = (S^2 \times W)/60 \text{ (for speed less than 45 mph)} = (55^2 \times 18)/60 = 907.5 \text{ feet}$$

Where: S = Posted speed (55 mph)

W= Transition Width (30 feet – 12 feet = 18 feet)

Corner Island Designs

At intersections of roadways where trucks make frequent right turns, a corner island, or raised channelization island, between the through lanes and the right-turn lane is a preferred alternative to an overly large corner radius. Corner islands generally are included in intersection design for one or more of the following purposes:

- Separation of conflicts;
- Control of angle of conflict;
- Reduction in excessive pavement areas;
- Regulation of traffic and indication of proper use of intersection;
- Arrangements to favor a predominant turning movement;
- Provisions for pedestrians, including accessible facilities;
- Storage of turning and crossing vehicles; and
- Location of traffic control devices.

Figure 3-23 shows the two different design approaches for right-turn corner islands, Traditional or High Visibility design. The following criteria is applicable for all corner island designs:

- If the channelized right-turning movement is not already stop or signal controlled, provide a yield sign for the movement.
- Unless the turning radii of trucks or buses need to be accommodated, the pavement of the channelized right-turn lane should be no wider than 16 feet; and to slow vehicles, the width of the travel lane should be restricted to 12 feet by marking the edge lines and using cross hatching based on engineering judgement.
- Refer to AASHTO Green Book, 7th Edition, Chapter 9.6.3.2 for additional design guidelines for channelizing islands.
- Refer to *TDOT Design Guidelines Chapter 3-805.00* for additional pedestrian considerations at corner islands.

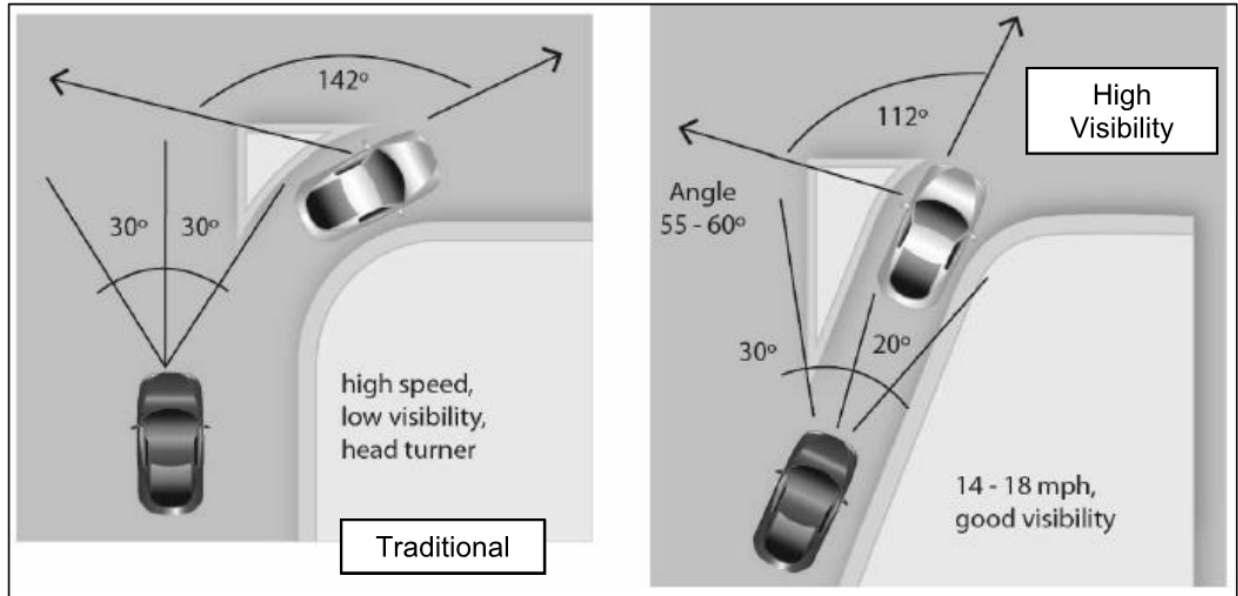

Figure 3-23: Right-Turn Corner Island Designs

Traditional corner islands are relatively symmetrical in shape. The following should be considered when using traditional geometrics for a channelizing right-turn island:

- They allow for higher speed vehicle turning movements.
- The possibility for higher turning speeds make these islands well suited for free flow turns.
- Large vehicle angles make it more difficult for right-turning drivers to see oncoming traffic prior to merging.
- Due to the higher turning speeds and reduced visibility, traditional islands are best suited for locations where pedestrian crossings are unlikely at the intersection.

The High Visibility corner island design has a more elongated nose towards vehicles entering the channelized right-turn area. The following should be considered when using a High Visibility corner island design:

- Turning vehicles should approach the intersecting traffic lanes at an angle greater than 55 degrees, and typically around 60 degrees.
- The larger intersection angle allows for less head turning of the right-turning driver and allows for greater visibility of oncoming traffic.
- The larger intersection angle encourages drivers to navigate the right-turn at lower speeds than the traditional corner island.
- The higher visibility and lower vehicular speeds make this corner island the preferred design when pedestrian crossings are likely at the intersection.

- Due to the larger intersection angle between right turning vehicles and intersection through lanes, it is often necessary to allow large trucks to turn and encroach into multiple receiving lanes or the opposing lane, making this design not practical for right-turns onto roads with only one through lane.

Intersection Grading and Tie-ins

All design standards for grading and tie-ins for intersections are included as part of *TDOT Standard Drawings* RP-I-5 and RP-R-1.

Intersections Located near the Limits of Construction

On new construction or reconstruction projects when an intersection is located at the beginning or end limit of construction the project shall comply with the following:

- A. If design of the intersection is included in the scope of the project defined by the technical report, the Designer shall include the entire intersection (i.e. place the construction limit at a point beyond the stop bar on the far side of the intersection from the project.) This includes installing updates to ensure all Americans with Disabilities Act (ADA) and Public Rights-of-Way Accessibility Guidelines (PROWAG) measures are met.
- B. If design of the intersection is not included in the scope of the work defined by the technical report, the Designer shall exclude the entire intersection (i.e. place the construction limit at a point no closer than the stop bar on the near side of the intersection from the project.)
- C. In no case shall the Designer place the construction limits between the stop bars of a signalized intersection.

Driveway Geometrics

All driveways connecting to State Routes shall be constructed according to either local government or TDOT standards, whichever standards are the strictest. Driveways shall be designed to adequately handle the anticipated volume and type of traffic generated. Design shall be governed by the largest vehicle expected to regularly use the entrance. It is important to note the design vehicle selected for the driveway geometrics should be based on entrance use and may not be the same as the overall corridor design vehicle.

Types of Roadway Access Driveways

Single or Two-Family Driveway: Driveways servicing single-family homes or duplexes are considered to be residential.

Field Entrance: This type of access is allowed to service farmland or other similar property. Driveways for such property are subject to the same regulations as a residential driveway.

NOTE: Owners wishing to construct either a residential driveway or field access shall contact the local TDOT District Office (see the TDOT Traffic Design website's Highway Entrance Permit page at [Highway Entrance Permits \(tn.gov\)](#) for a link to the District Offices).

Multi-Family Driveway: Residential properties consisting of more than two apartments or units are considered multi-family properties. Driveways for such complexes are subject to the same regulations as a commercial driveway.

Commercial Driveway: Driveways providing access to private property used for commercial purposes, or to public property, will be classified as commercial.

Street-Type Entrance: When development of a specified tract of property will generate 500 or more trips per day, a street-type intersection is typically required. For private development, a Traffic Impact Study may also be required at TDOT's discretion. Refer to the section on *Traffic Impact Studies* for additional information. This may include, but is not limited to, shopping centers, residential neighborhoods, industrial parks, or educational complexes. Also, when access is granted to new streets or roads, they shall be of the street-type design. Driveways for such complexes are subject to the same regulations as a commercial driveway.

Joint Access Driveways: The physical configuration of some properties makes it difficult to provide access adequate to serve certain types of development. Examples include uses that normally require two points of access to be developed on a lot with limited frontage, sites with access limitations caused by narrow frontage, frontage that does not span a median opening on a divided roadway, or corner clearance requirements. In these and other cases, it may be desirable to develop driveways that serve two or more properties. For private development jobs seeking a joint access driveway, all involved property owners must agree in writing to the construction of a joint access driveway for a permit to be issued.

Frontage Roads: Where there are several adjacent roadside establishments, each with relatively limited frontage, or where there is a probability of such development, consideration should be given to the provision of a frontage road for the several driveways so as to reduce the number of separate connections to the roadway. Where border width permits, the several driveways should be connected directly to such a frontage road paralleling the roadway with connections to the roadway only at the extremities of the frontage road or at well-spaced intervals along it. All private frontage roads shall be off of the right-of-way and shall be designed such that queuing at the primary access with the State Route does not affect traffic flow.

Outparcels: Frequently, when a large piece of commercial property is being developed, a high-volume traffic generator such as a large department store or movie theater will be the primary business at that location. However, a portion of the property may be divided into smaller outparcels, which will then be developed by smaller businesses. Since these establishments derive a substantial portion of their business from the traffic generated by the primary business, access to these outparcels should come within the shopping area itself, rather than each business having its own access point from a State Route. This will improve the overall safety of the area, reduce potential points of conflict and move traffic off of the main thoroughfare and into the shopping area. Access to outparcels are often dictated by local planned unit development (PUD) requirements. No future access should be permitted by TDOT unless revision have been made and approved through the local PUD.

Driveway Horizontal Geometry

Driveways shall be designed to accommodate the anticipated volume and type of traffic generated. Design shall be governed by the largest vehicle expected to regularly use the driveway. The primary horizontal geometry of a driveway are as follows, (see Figure 3-24):

- Radius of Curvature (R)
- Driveway Throat Width (W)
- Driveway Throat Length (T)
- Driveway Angle (Y)
- Driveway Edge Clearance (E)

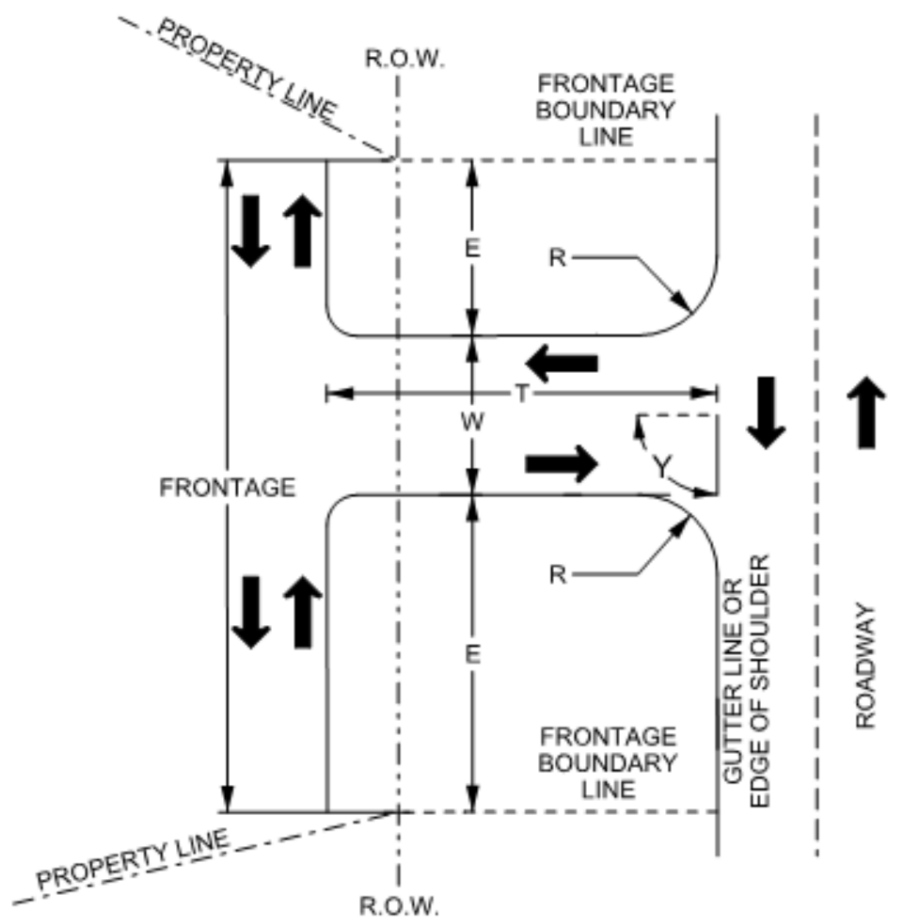

Figure 3-24: Horizontal Driveway Geometrics.

Refer to [Appendix A – Driveway Horizontal Geometry Example Figures](#) for additional examples of typical horizontal geometrics for driveways.

Driveway Radius of Curvature (R)

An adequate driveway turning radius shall be provided to facilitate safe entrance and exit of vehicles by creating a lower speed differential between through and turning vehicles. Urban areas, especially those with pedestrians present, allow for smaller radii to encourage decreased speeds for turning movements into the driveway to increase pedestrian safety. The edge of a driveway should be rounded to allow easy access of turning vehicles in and out of the driveway. Providing an appropriate turning radius prevents turning vehicles from encroaching onto the adjacent lane and or the oncoming traffic when turning into the driveway. Conversely, large radii can lead to oversized driveway aprons and can have adverse effects on pedestrian crossings when present. Table 3-14 provides minimum and maximum radii for typical driveway geometrics. An application for a deviation will be required to justify and document not meeting the designated criteria.

In Urban, Urban Core, Suburban, and Rural Town settings a concrete driveway with side flares instead of a radius of curvature may be required when sidewalks are present. Refer to *TDOT Standard Drawings* RP-D-15 and RP-D-16 for design guidance at these locations.

Table 3-14: Typical Driveway Radius of Curvature (R)

Driveway Radius of Curvature (R)			
Functional Classification	Property Type	Minimum	Maximum
Rural, Rural Town & Suburban	Residential	10 ft.	20 ft.
	Commercial	20 ft.	*
Urban & Urban Core	Residential	5 ft.	15 ft.
	Commercial	20 ft.	*

* Larger radius may be required if design vehicle is a single-unit truck or tractor trailer.

For street-type driveways that operate more like a street or intersection, such as a signalized commercial driveway, comfortably accommodating design vehicle turning movements may require larger radii than what is designated in Table 3-14. Table 3-15 provides requirements for driveway radius of curvature for those higher volume driveways. In those situations, design vehicle turning paths should be studied to ensure the functional needs of the driveway can be met.

An application for a deviation will be required to justify and document not meeting the designated minimum criteria. Refer to the section on *Deviations from Access Manual Criteria* for the procedures that must be followed. Excessively large radii should be avoided at intersections where pedestrians are present or may be present in the future. Larger radii encourage higher vehicular turning speeds and also increase the crossing distances for pedestrians. When larger radii are required for an intersection, a corner islands should be considered.

Table 3-15: Required Intersection or Street Type Driveways Radius of Curvature (R)

Street-Type Driveways Radius of Curvature (R)		
Vehicle Type	Minimum	Recommended
Passenger Cars	25 ft.	30 ft.
Single-Unit Trucks, Buses or WB-40 Tractor Trailers	40 ft.	40 ft. **
WB-50 Tractor Trailers or Larger	40 ft.	50 ft. **

** Larger radius may be required (maximum of 75 feet) if turning template analysis demonstrates a need to prevent off-tracking for larger vehicles.

Driveway Width (W)

The allowable width of a driveway is tied to the number of lanes, anticipated use, and design vehicles associated with the driveway. Table 3-16 provides the allowable minimum and maximum width for a driveway. An application for a deviation will be required to justify and document not meeting the designated criteria. Refer to *Deviations from Access Manual Criteria* for the procedures that must be followed.

Generally, street-type driveway entrance widths shall be limited to 50 feet. For private development jobs, TDOT may elect to allow for additional width if it is determined through a Traffic Impact Study that extra lanes are warranted for street-type entrances. Refer to the section on *Traffic Impact Studies* for guidance. Regardless of driveway entrance width, private developments may not construct non-traversable medians or any other roadside hazards, within the intersecting roadways right-of-way. The TDOT Regional TSMO Manger may allow exceptions to this criteria to provide median refuge at pedestrian crossings or when channelizing medians are required for restricting specific traffic movements.

Table 3-16: Required Driveway Width

Driveway Width Requirements (W)				
Driveway Type	One-Way Driveways		Two-Way Driveways	
	Minimum	Maximum	Minimum	Maximum
Single Family or Duplex	12 ft.	16 ft.	14 ft.	24 ft.
Multi Family	12 ft.	20 ft.	24 ft.	40 ft.
Commercial or Industrial	12 ft.	24 ft.	24 ft.	40 ft.*

* Where developments are expected to serve a substantial volume of heavy vehicles (6 or more tires), this dimension may be increased to 50 feet.

Driveway Throat Length (T)

Throat length is the distance measured along a driveway between the outer edge of the traveled way of the roadway to which the driveway connects and the first point along the driveway at which there are conflicting vehicular traffic movements.

The driveway throat is designed to facilitate the movement of vehicles off the roadway to prevent the queuing of vehicles onto the traveled way. Throat length criteria only applies to driveway design. When the access point is considered to be a major or minor roadway, minimum driveway spacing, intersection spacing, and corner clearance will govern.

The following general guidance should be considered when assessing driveway throat length:

- The length should be sufficient to keep vehicles that are maneuvering in the throat region from protruding into areas for other users.
- The length should be sufficient to prevent queues in the throat from interfering with traffic (bicycle, motor vehicle, pedestrian) in the public roadway or within the site.
- If activity on a site causes traffic to queue, the length of the throat should be sufficient to keep the queue from spilling back into the public roadway.
- The throat length and distance between conflict points should be sufficient to allow users to react to individual conflicts ahead.

The minimum throat length requirements shown in Table 3-17 are based on the traffic a development will generate, not the characteristics of the abutting roadway. The more traffic using the driveway, the greater the number of ingress/egress lanes will be needed within the entrance, which determines the length of the driveway throat. For private developments, this criteria is typically determined in a Traffic Impact Study.

Where feasible all driveways should meet the minimum criteria for throat length. Only private developers seeking a driveway permit for a new or modified driveway or TDOT roadway jobs on new alignment shall be required to meet the throat length criteria. In the instances where the criteria in Table 3-17 is required but cannot be met, the guidance in the section on *Deviations from Access Manual Criteria* must be followed.

Table 3-17: Minimum Driveway Throat Length Requirements^{29, 30}

Minimum Driveway Throat Length (T)	
Number of Egress Lanes (left, thru and right)	Minimum Throat Length Feet
1	35 ft. *
2	75 ft.
3	200 ft.
4	300 ft.

* Inadequate driveway length can also provide hazards to entering traffic on site. Particularly where the on-site parking can back out of and block the entrance and prevent a vehicle from entering. To avoid this problem, a distance of at least 50 feet is used on entrance length where back out parking may interfere with entry movement, as shown in Figure 3-25.

²⁹ TRB, Access Management Manual 2nd Edition (2014)

³⁰ VDOT, Roadway Design Manual, Appendix F, Access Management Design Standards for Entrances and Intersections (2014)

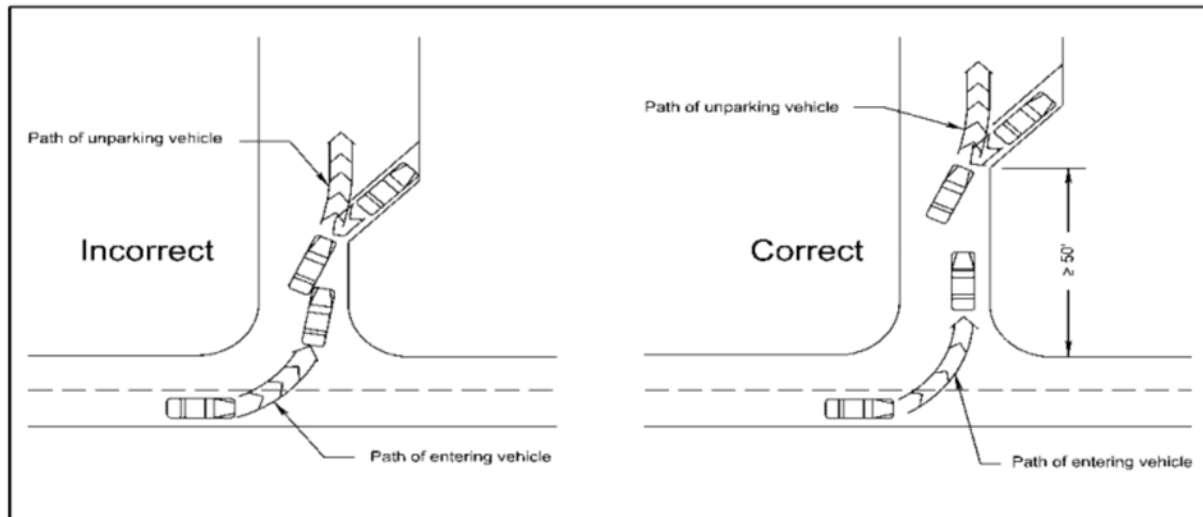

Figure 3-25: Driveway Throat Length Accommodation for Parking Conflicts²⁰

Driveway Edge Clearance (E)

Edge Clearance represents the distance, measured parallel to the roadway, that a driveway must be offset from the property line limits, also referred to as the frontage boundary. Refer to the figures in *Appendix A – Driveway Horizontal Geometry Example Figures* for examples of how and where to measure edge clearance. All portions of a driveway including radii, shall lie within the frontage boundary lines. At no time shall the edge clearance be less than the radius of curvature for the junction of the driveway and the edge of pavement. An application for a deviation will be required to justify and document not meeting the designated criteria in Table 3-18. Refer to the guidance in *Deviations from Access Manual Criteria*.

Table 3-18: Required Edge Clearance (E) for Driveways

Driveway Edge Clearance (E)		
Functional Classification	Property Type	Minimum
Rural, Rural Town & Suburban	Residential	10 ft.
	Commercial	20 ft.
Urban & Urban Core	Residential	5 ft.
	Commercial	20 ft.

Driveway Angle (Y)

The driveway angle shall be measured as the angle at which the driveway centerline and the adjacent edge of traveled way intersect. Driveway angles shall be designed as follows:

Driveways for two-way operation

- 90 degrees (Recommended)
- 70 degrees (Minimum) with approval from TDOT Regional TSMO Engineer

Driveways for one-way operation

1. Driveways used by vehicles turning from both directions on the roadway shall be the same requirement as for two-way operation.
2. Restricted access driveways used by vehicles traveling in one direction on the roadway (right-in, right-out only): 60 degrees to the centerline of roadway preferred; may be reduced to 45 degrees (with the approval of TDOT).

When the criteria for driveway angle cannot be met, refer to the guidance in *Deviations from Access Manual Criteria*.

Driveway Corner Clearance (C)

Corner clearance (C) represents the minimum distance a driveway on a minor side road needs to be separated from an intersection to prevent queued vehicles from backing up into the roadway or blocking entrances near the intersection. Unlike driveway spacing, which is measured from centerline of intersection to centerline of driveway, corner clearance shall be measured from the edge of the driveway to the edge of the right-of-way, see Figure 3-26. This separation protects the functional area of the intersection.

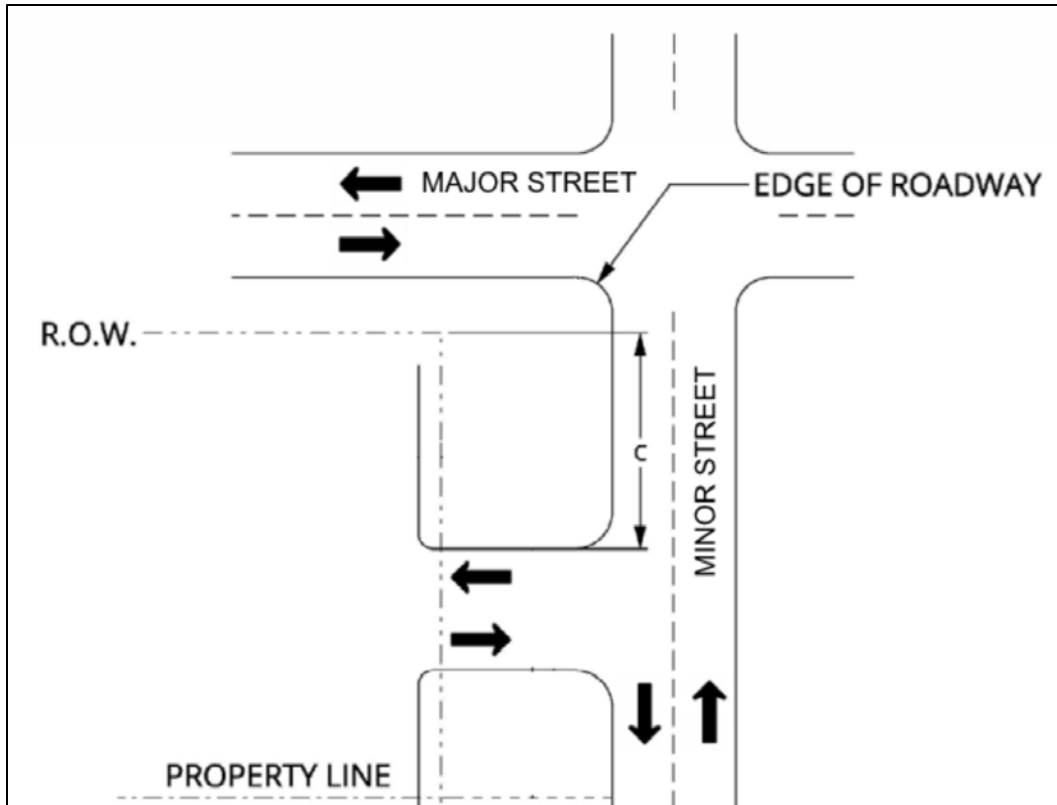

Figure 3-26: Corner Clearance "C" for Driveways

Generally, driveways shall be placed as far from an intersection as practically possible. Minimum driveway spacing criteria as laid out in Table 3-5 and Table 3-6 shall serve as the controlling design criteria for driveway placement along a major or minor road. Corner Clearance requirements in Table 3-19 shall only govern when:

- Corner Clearance requirements are greater than minimum driveway spacing requirements.
- Property frontage length cannot accommodate minimum driveway spacing requirements, but an entrance is still required along the minor road.

When the required minimum spacing for driveways in Table 3-5 and Table 3-6 cannot be met but a driveway must still be placed using corner clearance criteria, a restricted access driveway shall be required. When these driveway spacing requirements or corner clearance requirements cannot be met, application for a deviation will be required. Refer to the guidance in *Deviations from Access Manual Criteria*.

Table 3-19: Required Minimum Corner Clearance

Classification of Intersection Major Road	Functional Classification of Road to be Accessed by Driveway		
	Arterial	Collector	Local
Arterial	200 ft.	150 ft.	100 ft.
Collector	150 ft.	100 ft.	50 ft.
Local	100 ft.	50 ft.	50 ft.

Additional Commercial Driveway Requirements

Along with geometric design criteria listed above for all driveways, applicable commercial driveways will also be subject to the following additional criteria. Refer to *Deviations from Access Manual Criteria* for the procedures that must be followed when the criteria cannot be met.

Distance between Double Driveways (D):

Distance between Double Driveways shall be measured from driveway edge to driveway edge. When a double driveway is allowed, driveways must be a minimum of 40 feet apart. This criterion is only applicable when both driveways are serving one directional traffic. An example would be if the first driveway exclusively served traffic exiting the roadway and the second driveway exclusively served traffic entering onto the roadway. Refer to *Appendix A – Driveway Horizontal Geometry Example Figures* for schematics of where this distance is applicable. Spacing between driveways that serve two-way traffic will be subject to minimum driveway spacing requirements in Table 3-5 and Table 3-6.

Fuel Pump Clearance (F):

Where applicable, fuel pumps shall be placed so that refueling vehicles will not be parked or serviced on state right-of-way. Refer to *Appendix A – Driveway Horizontal Geometry Example Figures* for schematic examples of Fuel Pump Clearance (F). The pumps shall be placed the following distances from the right-of-way line(s):

- Pumps parallel to right-of-way line – 15 foot minimum;
- Pumps perpendicular to right-of-way line – 25 foot minimum; 50 foot recommended; and
- Pumps at any other angle to right-of-way line – 25 foot minimum; 50 foot recommended.

Commercial Border Area Clearance (CB):

Commercial border area clearance represents distance, measured perpendicular from the right-of-way, that shall remain clear of paving and improvements. Refer to [Appendix A – Driveway Horizontal Geometry Example Figures](#) for schematic examples of Commercial border area clearance (CB). Commercial border area clearance shall be at least three (3) feet. If border area clearance is less than six (6) feet from the right-of-way line a six (6) inch raised curb shall be required. This clearance (and use of the six (6) inch curb) is designed to prevent vehicles from parking or being serviced within the right-of-way line.

Driveway Grading & Profile

In the interest of safety, driveways shall be designed to minimize storm water flow from the driveway onto the public roadway. If there is a curb, the design should also minimize the diversion of storm water flowing against the curb in the driveway.

Driveways should be free of any vertical discontinuities that adversely affect the flow of vehicles. The vertical alignment should include a sufficiently small rate of grade change to provide adequate ground clearance and avoid scraping or hanging-up the undersides of vehicles, see Figure 3-27. Driveway grade is important because turning vehicles must slow down to enter a driveway. The steeper the driveway, the greater the reduction in speed required to prevent hitting the bottom of the vehicle against the pavement.



Figure 3-27: Example of Ground Clearance Issues Related to Driveway Profile.

Driveways shall also conform to the requirements of the ADA, making pedestrian crossings accessible to people with disabilities.

In addition to [TDOT Standard Drawings](#) RP-I-5 and RP-R-1, the following design criteria shall be required for all driveways adjacent to State Routes. Refer to Figure 3-28 for a schematic of all driveway profile criteria.

Grading for Residential Driveways and Field Entrances on Roads Without Curb & Gutter

For driveways classified as residential or field entrances along roads without curb & gutter, the portion of any driveway within the right-of-way shall satisfy the following criteria:

- Driveway grade should not exceed 15 percent (10 percent recommended).
- From the edge of traveled way to the outer edge of the shoulder, the driveway grade should match the existing shoulder grade.
- For cut sections – from the outer edge of the shoulder to the low point at the ditch line or over a culvert, the grade should not exceed eight (8) percent (five (5) percent is recommended). Beyond the ditch line, the maximum grade allowed is 15 percent (10 percent recommended).
- For fill sections - beyond the outer edge of the shoulder, the grade should not exceed 15 percent (10 percent is recommended).
- The maximum allowable difference in grade between intersecting grade lines should not exceed 10 percent in crests and nine (9) percent in sags.
- The minimum separation distance between changes in grade, or minimum length of a profile tangent, should be 10 feet.

Grading for All Other Driveways Without Curb & Gutter

For driveways along roads without curb & gutter serving all other uses, the portion of any driveway within the right-of-way shall satisfy the following criteria:

- Driveway grade should not exceed eight (8) percent (five (5) percent is recommended).
- From the edge of traveled way to the outer edge of the shoulder, the driveway grade should match the existing shoulder grade.
- For cut sections – from the outer edge of the shoulder the grade should not exceed eight (8) percent (five (5) percent is recommended).
- For fill sections – beyond the outer edge of the shoulder, the grade should not exceed eight (8) percent (five (5) percent is recommended).
- The maximum allowable difference in grade between intersecting grade lines should not exceed 10 percent in crests and nine percent in sags.

Grading for Driveways on Roads with Curb & Gutter

Drives on roads with curb & gutter shall satisfy the following criteria:

- Driveways should slope upward from the gutter line to meet the sidewalk (if applicable).
- Descending driveways are to be constructed in a manner which prevents water from leaving the roadway gutter.

- The maximum allowable difference in grade between intersecting grade lines should not exceed 10 percent in crests and nine percent in sags.
- Driveway grade must not exceed 2.0 percent across a sidewalk (1.5 percent is desirable).
- Beyond the outer edge of the sidewalk (or an equivalent point) the maximum allowable grade should not exceed eight (8) percent (five (5) percent recommended) for commercial applications and 15 percent (10 percent recommended) for residential applications.

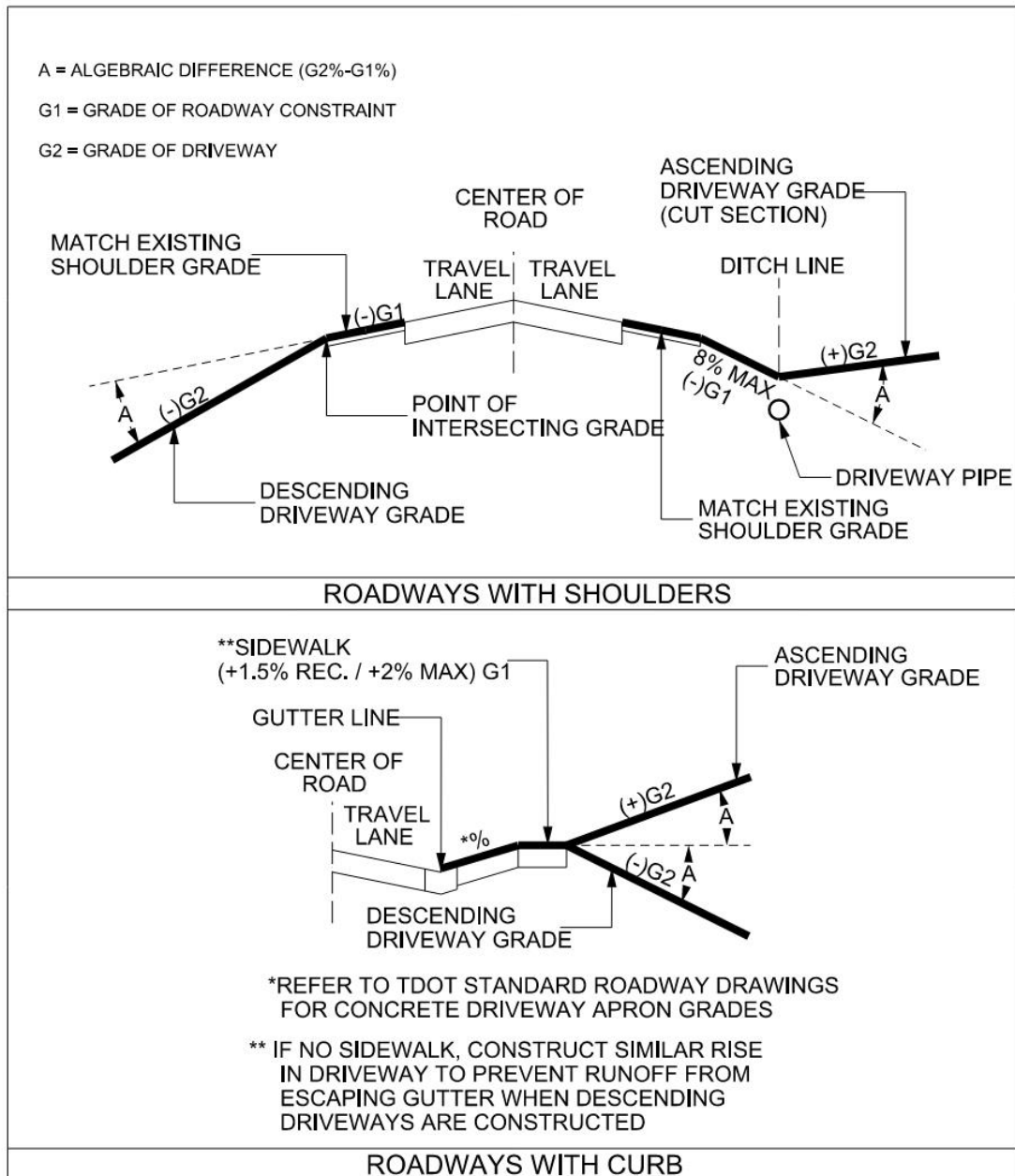

Vertical Curves for Driveway Profiles

All driveway vertical curves should be designed as flat as possible to prevent vehicles from dragging on the pavement. This is especially important when developments are expected to serve a substantial volume of oversized vehicles (five or more vehicles per day with three or more axles). The maximum break in pavement grade, as well as all other appropriate factors, including vertical curve characteristics, should be checked by the designer to ensure adequate clearance for the long wheelbase of the oversize vehicles. Refer to *TDOT Standard Drawing* RP-R-1 for minimum K values for driveway profile vertical curves.

Driveway Cross Slope

Positive drainage should be maintained throughout the length of the driveway. One driveway edge may be higher than the other or the center line may be higher than the edges, creating driveway cross slope. Where the driveway and sidewalk intersect, the driveway cross slope is the same as the sidewalk grade.

Driveway Edge

A driveway edge should be clearly defined and visible to all users. The designer should avoid sudden drop-offs along the edge of drive. Fixed objects such as utility poles, fire hydrants, and drainage inlets should be set back from the edge of the driveway and from the edge of the roadway. If there is a side drain and the side drain is within the clear zone, maintain mainline side slopes through the safety endwall. If a parallel side drain is not required, 2:1 slopes may be used beyond the driveway radius. Designers should review the roadway and driveway slopes to ensure that a non-traversable slope within the clear zone is not created when the drop off is five foot or more.

Driveway Sight Distance

Roadway entrances shall be located to provide adequate sight distance for all traffic movements allowed. Where sight distance requirements are not met, specific movements may be restricted. Additional grading work to ensure proper sight distance requirements are met may be required as well.

Sight distance requirements shall be in accordance with *TDOT's Standard Drawing Series RD11-SD*. An application for a deviation will be required to justify and document not meeting the designated criteria; refer to the guidance in *Deviations from Access Manual Criteria*. Refer to Figure 3-29 and Figure 3-30 for guidance on establishing proper Driveway Sight Distance.

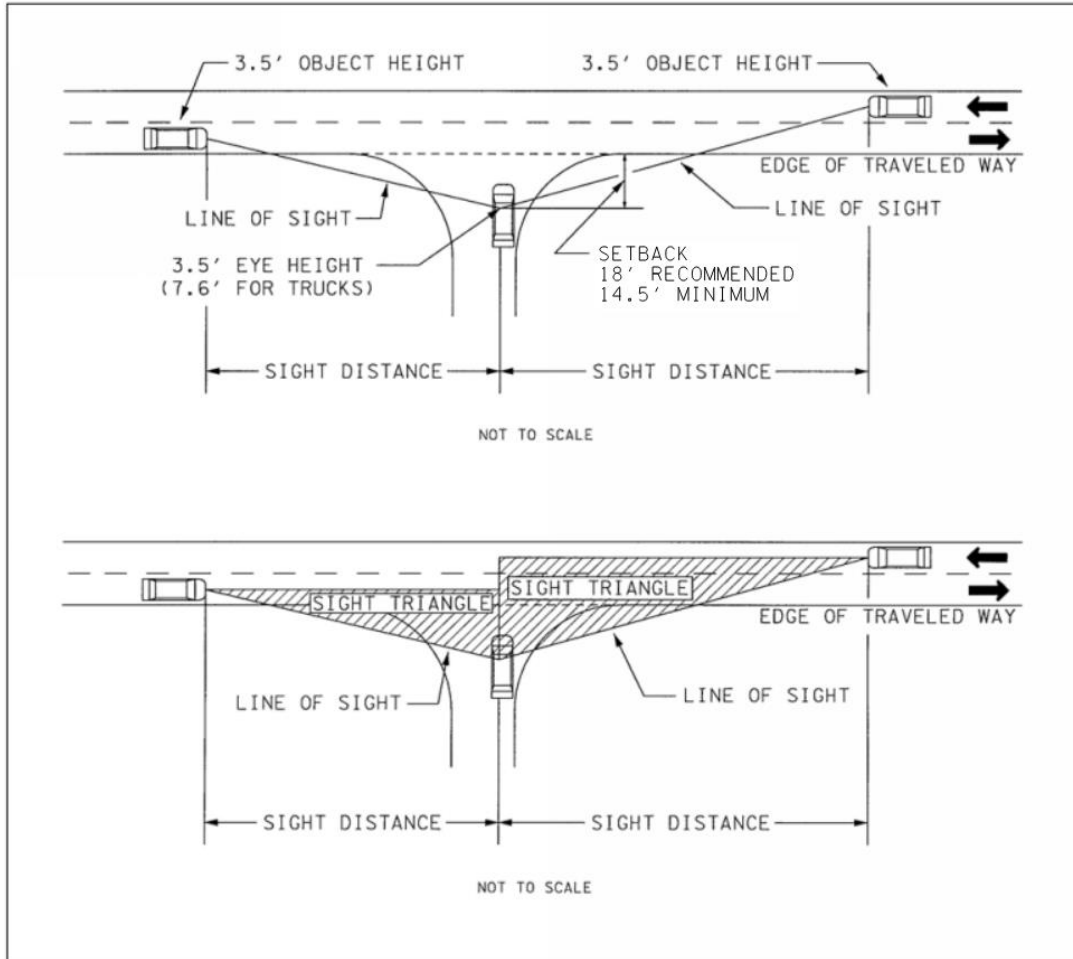

Figure 3-29: Driveway Sight Distance and Sight Triangles

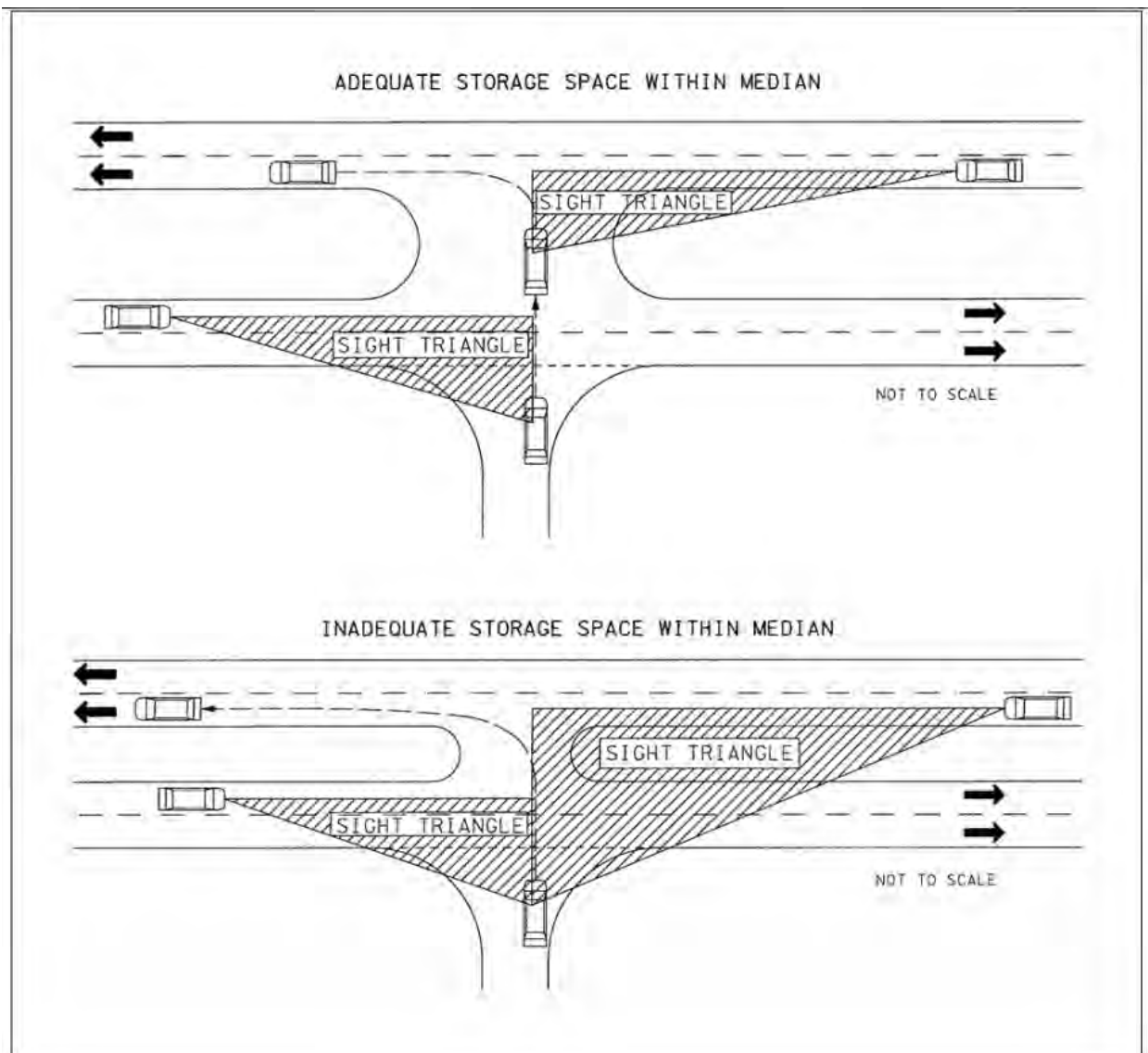

Figure 3-30: Driveway Sight Distance at Divided Roadways

Multimodal Roadway Design in Driveways

Multimodal components must be considered when designing driveways. Driveway guidance has traditionally focused on accommodating motor vehicles, but now emphasis is also being placed on managing access and accommodating pedestrians and cyclists. The design of a driveway affects the safety and mobility of motorists, cyclists, and pedestrians. See *TDOT Design Guide, Chapter 3* for additional information for multimodal components.

Pedestrian Safety in Driveways

In order to comply with State and Federal requirements, pedestrian access needs to be considered while designing driveways. The following information should be addressed where applicable:

- For pedestrian facilities in driveways see *TDOT Standard Drawings* RP-D-15 and RP-D-16. To assist pedestrians with visual impairments, detectable warning surfaces/truncated domes should be provided where commercial driveways have a yield or stop control at the junction between the sidewalk and the driveway vehicle route. Detectable warning surfaces are not required for residential driveway crossings. Yellow is the last color a visually impaired person can detect; therefore, truncated domes shall be yellow in color.
- For driveways with raised channelized islands, the island should be at least six feet in width and have flat area for pedestrians in wheelchairs.
- When the pedestrian sidewalk crosses the existing driveways, the maximum cross slope at any point on a sidewalk is two percent (1.5 percent is desirable).

If the driveway touchdown point is at the back of sidewalk, see *TDOT Standard Drawings* RP-D-15 and RP-D-16.

Medians

A median is the portion of a roadway separating opposing traffic flows. Medians can be depressed, raised, or flush with the traveled way. Medians are also typically classified as traversable or non-traversable. Traversable medians do not physically discourage or prevent vehicles from entering or crossing over it, such as a painted median or two-way left-turn lanes. Non-traversable medians include physical barriers such as raised curb and gutter, concrete barrier, landscaped island, and or depressed ditch to prohibit traffic movement across the median. Properly designed medians provide many benefits including:

- Vehicular safety – medians reduce crashes caused by traffic turning left, head-on and crossover traffic, and headlight glare, resulting in fewer and less severe crashes.
- Pedestrian safety – non-traversable, medians provide a refuge for pedestrians crossing the roadway. Fewer pedestrian injuries occur on roads with restrictive, non-traversable, medians.
- Operational efficiency – medians improve traffic flow by removing turning traffic from through lanes. A roadway with properly designed medians can carry more traffic, which can reduce the need for additional through lanes.
- Aesthetics – in addition to safety and operations, medians can improve the appearance of a corridor. If landscaped, the median can lessen storm water runoff and enhance air quality.

Median Widths

Median width is the perpendicular distance measured between the inside edges of traveled way for traffic lanes flowing in opposite directions. For divided roadways, inside shoulder width is included as part of the overall median width. Figure 3-31 shows the typical median width measurement locations.

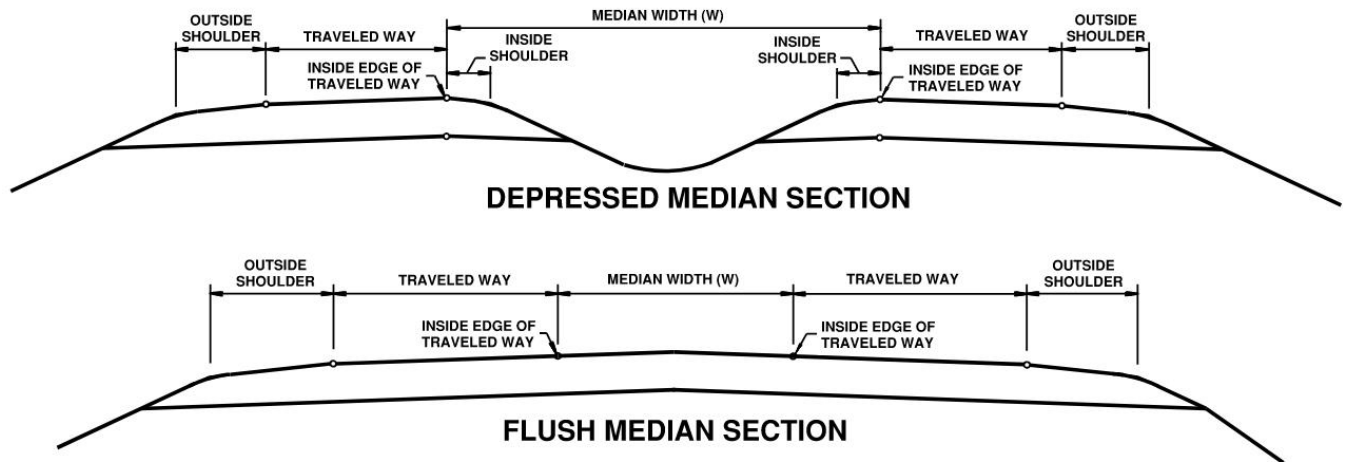

Figure 3-31: Median Width Measurement

TDOT's RD11-TS series of *Standard Drawings* provides minimum median width values based on roadway classification (collector, arterial, freeway) and median type (depressed, flush, barrier separated). While the standard drawings provide minimum values for median widths, these widths still need to be designed to accommodate the dimensions and turning paths of the vehicles that can be expected to use the opening. Table 3-20 provides additional guidance of minimum median widths required to accommodate specific functions of the median.

Table 3-20: Minimum Median Widths for Specific Median Functions

Minimum Median Width	
Median Function	Minimum Width
Separation of opposing Traffic	8 ft.*
Provisions for storage of left-turning vehicles	16 ft.**
Provisions for storage of left-turning vehicles with pedestrian refuge	18 ft.***
Provision for protection of vehicles crossing through lanes	22 ft.
Provision for U-turns, left turn lane to outside lanes	30 ft.****
Provision for Dual Left-Turn Lanes and U-turns	30 ft.
Provision for Dual Left-Turn Lanes and U-turns	42 ft.***

* Width allows for pedestrian refuge within the median when required. A minimum of 6 ft is allowed per Standard Drawing T-M-4 series.

** Provision is for a 12-foot turn lane width + 4-foot median separation of opposing traffic. Could be reduced if turn-lane width is less than 12 feet.

*** Provision is for 12-foot turn lane(s) width + 6-foot median separation of opposing traffic. Could be reduced if turn-lane width is less than 12 feet.

**** This width only accommodates a Passenger Vehicle U-Turn, see the section on *U-Turn Geometrics* if larger vehicle accommodation is required.

Left Turn Lanes in Medians

Left turn lanes can be added at median openings to provide vehicle refuge, allowing deceleration and storage of turning vehicles away from full speed through traffic. Refer to the previous subsection on *Turning Lanes* under the Intersection Geometrics section of this manual for guidance on sizing, tapers, and warrants associated with left turn lanes.

At median openings along a major roadway for access to driveways, intersecting roadways, or U-turn accommodations, median width should be considered for warranting an exclusive left-turn lane. When median width is sufficiently wide to accommodate a full-width left-turn lane without impacting or shifting through lane geometrics, a left-turn lane should be considered, even when traffic volumes alone do not warrant the lane.

As discussed in the AASHTO Greenbook, 7th Edition, Chapter 9, it is desirable to align left-turn lanes in medians – see Figure 3-32. The advantages of this placement include:

- Better visibility of opposing through traffic as left turners look for gaps.
- Decreased conflict between opposing left-turn vehicle paths.
- Increased numbers of left-turn vehicles served in a given period of time. The farther left the turn lane, the shorter the crossing distance for left-turn vehicles, allowing drivers to choose shorter gaps in opposing traffic and clear the intersection. There is also an increase in capacity at signalized intersections, due to more flexibility in left-turn phasing and shorter clearance intervals.

The following guidelines apply to four-lane divided highways with a maximum median width of 48 feet. For medians greater than 48 feet, designers should offset left turn lanes to reduce the length required for the left turn onto an intersecting road.

The centerline of left-turn lanes shall be placed along the centerline of the median, so that opposing left-turn lanes are directly opposite each other. Excess pavement area between the turn lane and adjacent through lane shall be marked with channelization striping (see Figure 3-32, *Left-Turn Lane Alignment*).

The Average Daily Traffic (ADT) criteria as shown in *Table 3-21, Future Traffic Signal Warrants*, can be used to estimate if a traffic signal will be warranted within five years of project opening. If the current major street ADT and minor street ADT both meet the criteria for Warrant 1 or Warrant 2, future signalization is probable, and the intersection design shall provide aligned left-turn lanes.

The number of approach lanes on the major street includes only through lanes. The same is true for the minor street, except in the case of "T"-intersections. For "T"-intersections, the number of approach lanes shall include left and right-turn lanes (if present) for the stem of the "T" as the minor street.

If the major street ADT differs on each side of the intersection, an average shall be used. For the minor street, use the higher ADT on the higher volume approach.

Be aware that there may be special conditions affecting signalization or geometric design. For those unusual conditions, the TDOT Traffic Operations Division can provide assistance.

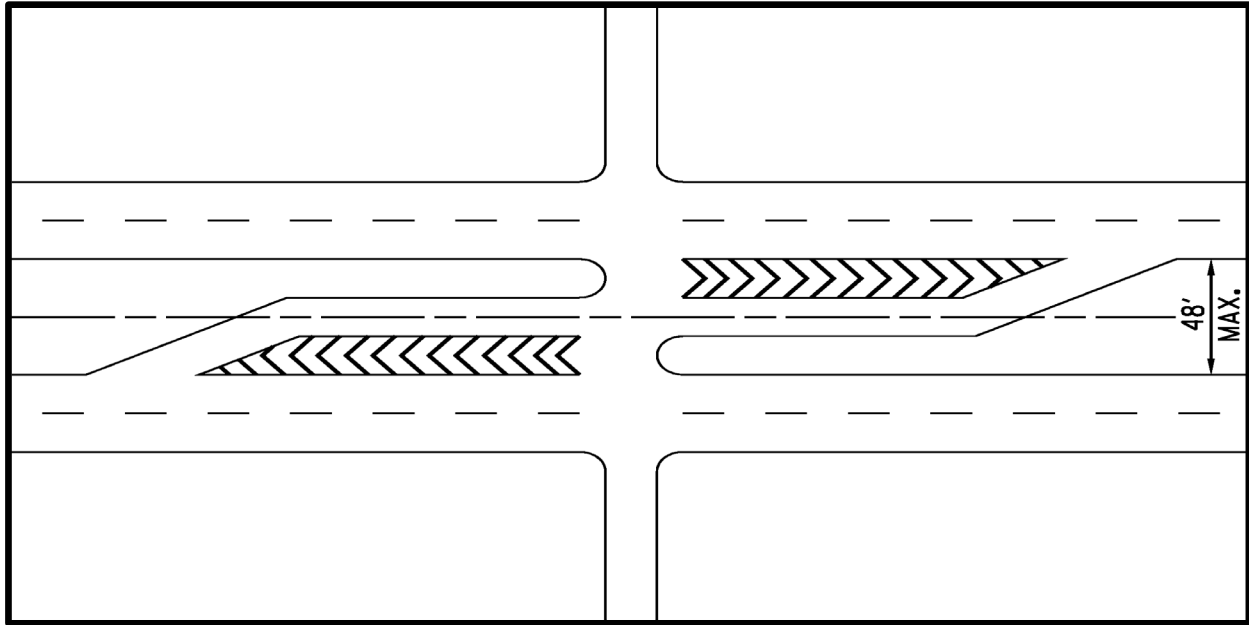

Figure 3-32: Left-Turn Lane Alignment

Table 3-21: Future Traffic Signal Warrants

NUMBER OF APPROACH LANES		WARRANT 1		WARRANT 2	
Major	Minor	Major ADT	Minor ADT	Major ADT	Minor ADT
1	1	5000	3000	7500	1500
2 or more	1	6000	3000	9000	1500
2 or more	2 or more	6000	4000	9000	2000
1	2 or more	5000	4000	7500	2000

Two-Way Left-Turn Lanes

Continuous two-way left-turn lanes (TWLTLs) are typically used to improve traffic flow on two-lane and four-lane undivided roadways. When compared to undivided roadways, roadways with continuous TWLTLs:

- Are generally safer, with 35 percent lower average crash rates;
- Have increased capacity; and
- Experience less delay.

In contrast, TWLTLs do not provide the safety benefits of non-traversable medians and have the potential for overlapping left-turn movements. TWLTLs do not provide positive control over left-turns, and they encourage frequent access points in commercial strip developments. The following recommendations should be considered when determining the installation of a TWLTL:

- A three-lane section with TWLTL should have ADT less than 17,000 vehicles per day (VPD);
- A five-lane section with TWLTL should have ADT less than 28,000 VPD;
- Posted speeds should be less than 45 mph to warrant TWLTL;
- A seven-lane section with TWLTL is strongly discouraged due to safety concerns; and
- Left-turning movements across three or more lanes of opposing traffic is strongly discouraged at unsignalized intersections and access points.

When the criteria cannot be met, a non-traversable median should be considered for the roadway. When TWLTLs are selected they should have one-way, delineated left-turn lanes at points with highly concentrated left-turning traffic. Exclusive Left-turn lanes should be provided instead of a TWLTL where left-turning volumes from the median to single access point exceed:

- 150 veh/h across one lane of opposing traffic; or
- 100 veh/h across two lanes of opposing traffic to a specific access point.

U-Turn Guidance

Along corridors with non-traversable medians, U-turns can be used as alternatives to direct left turns. Benefits of U-turns include:

- Reduce conflicts and improve vehicular safety;
- 50 percent fewer conflicts than direct left-turns;
- Make it possible to prohibit left-turns from driveway connections onto multi-lane roadways;
- Can eliminate traffic signals that would not fit into the time-space patterns along arterial roads;
- When incorporated into intersection designs, they enable direct left-turns to be rerouted and signal phasing to be simplified; and
- When coupled with two-phase traffic signal control, they result in roughly a 15 to 20 percent gain in capacity over conventional intersections with dual left-turn lanes and multi-phase traffic signal control.

U-Turn Geometrics

In order to properly accommodate a U-Turn, a wide enough median is required to accommodate the turning path of the vehicle. When the median width cannot accommodate a necessary U-Turn maneuver, a pavement bulb-out, also known as a flare-out, shall be designed to accommodate the over-turning maneuver. Refer to Table 3-22 for a general schematic for both designs and the minimum median widths required for the respective U-Turn maneuvers to the outside .

Table 3-22: Minimum Required Median Widths of U-Turn Maneuvers

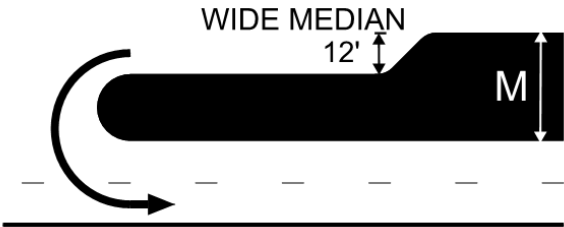
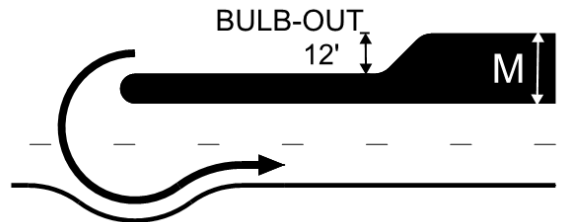
Type of Maneuver	M - Minimum Width of Median for Design Vehicle **	
	P	SU-30 / BUS
	30 ft.	63 ft.
	18 ft.	51 ft.

** Refer to AASHTO, the Green Book, 7th Edition, Table 9-28 for median widths for larger vehicles.

U-turns should not be permitted from the through traffic lane because of the potential for high speed, rear-end crashes. U-turns should be made from a left-turn/U-turn lane when feasible.

Large Vehicle Accommodation For U-Turns

Extremely wide medians that are required for buses and trucks to make a U-turn makes it impractical to design for these vehicles except in special cases. The need for U-turns by large vehicles can generally be avoided in the following ways:

- Bus and truck delivery routes can be planned to eliminate the need for U-turns on a major roadway.
- Driveways can be adjusted and on-site circulation designed to eliminate the need for U-turns by trucks.

When a U-turn is required for larger design vehicles, consider the use of Jug Handles to accommodate U-turns (and left turns), as shown in Figure 3-33. In most cases Option “B” would need a signal. Option “A” has the following desirable operational features:

- The U-turning vehicle is stored in the median parallel to the through traffic lanes.
- A suitable gap is needed in the opposing traffic stream only.
- After completion of the U-turn, the driver can accelerate prior to merging into the through traffic lane.

These options require more right-of-way than most standard roadway designs, but it may be more cost feasible where public land is available. In addition, consider impacts and safety to pedestrians and non-motorized travel as jug handles can have adverse impacts to multimodal modal design.

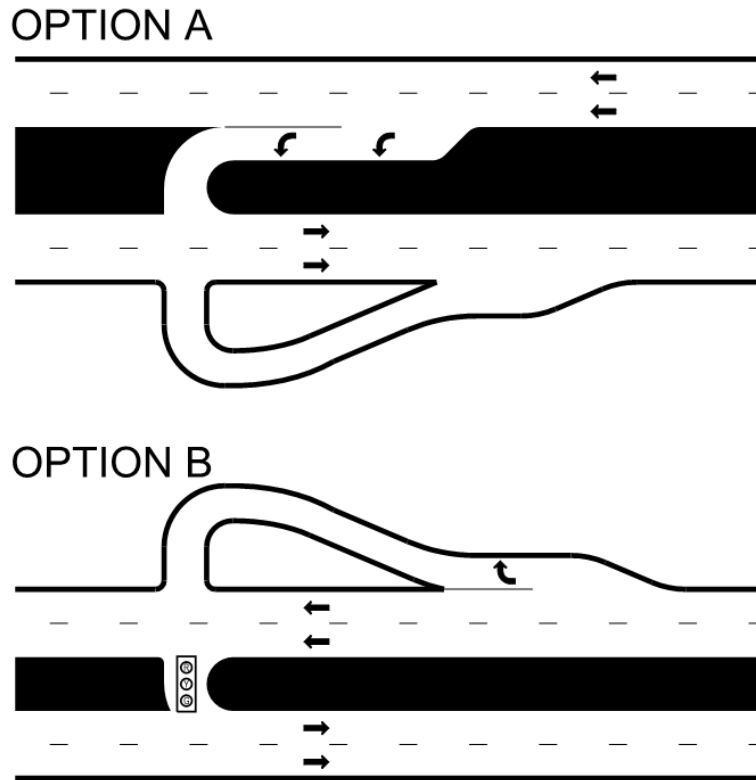

Figure 3-33: Jug Handle Designs for Large Vehicle U-Turns

U-turn at Signalized Intersections

U-turns can be made at a signal when:

- The median is of sufficient width; and
- There is a low combined left-turn plus U-turn volume at a signalized single left-turn lane.

Designers should also consider the following at these locations:

- Consider “right-on-red” restrictions for the side roads;
- Signal operation including right-turn overlaps; and
- U-turns take more time to clear the intersection than left turns.

Where medians are of sufficient width to accommodate dual left-turn lanes, designers could consider allowing U-turns from the inside (left-most) left-turn lane as shown in Figure 3-34.

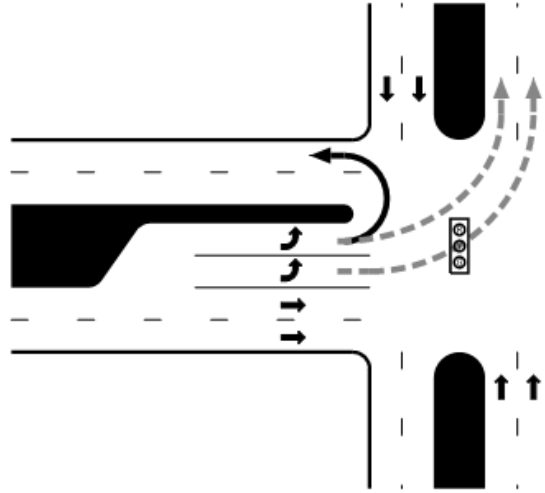

Figure 3-34: U-Turns at Dual Left-Turn Lanes

U-turns in Advance of a Signal

A U-turn in advance of a signalized intersection will result in two successive left-turn lanes as shown in Figure 3-355. At these locations, the median opening for the U-turn will still be subject to the minimum restricted access median opening spacing requirements in Table 3-8, with a recommended distance of 660 feet. In addition to those requirements, the turn lane for the U-turn must be placed in a way that there is at least 100 feet of full median width prior to the taper for the left-turn lane at the intersection. This will help to prevent drivers from mistakenly entering the U-turn lane when they intended to utilize the left-turn lane at the intersection. When 100 feet is not possible, signage or other pavement markings should be used to help guide motorists.

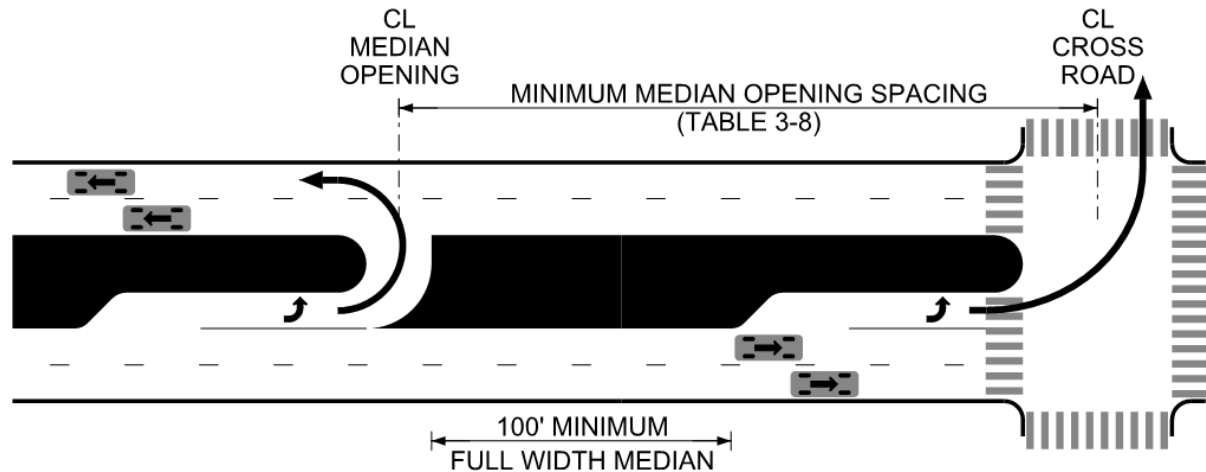

Figure 3-35: U-Turn in Advance of an Intersection.

U-turn openings before signalized intersections could be considered when:

- There is a high volume of left turns currently at the signalized intersection.
- There is a high volume of right-turns at intersection that would conflict with U-turn maneuvers.
- A gap of oncoming vehicles would be beneficial at a separate U-turn opening.
- There is sufficient space to separate the signalized intersection and U-turn opening.
- U-turns at the cross road intersection conflict with pedestrians.

U-turns After a Signal

Placing a U-turn after a traffic signal also requires the U-turn to follow the minimum restricted access median opening spacing in Table 3-8, with a recommended distance of 660 feet. By placing U-Turns after signalized intersections, this allows some alternative intersection solutions like the Median U-turn intersection as shown in Figure 3-36 or a J-Turn intersection as detailed in the *Design Guidelines Chapter 2-603*. These intersections allow for simplified signal phasing and provide a greater intersection capacity than direct left-turns. They are also associated with a significant crash reductions and improved pedestrian crossing safety when compared to a typical direct left intersection.

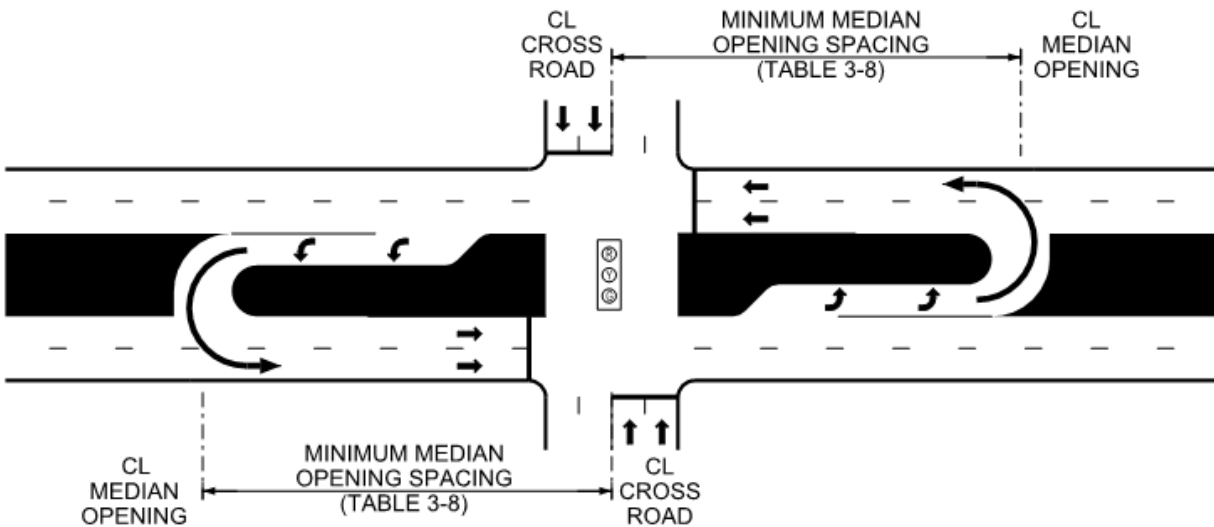

Figure 3-36: Schematic of a Median U-Turn Intersection

Deviations from Access Manual Criteria

It is recognized that certain developments and access points, due to location, frontage, topography, or other conditions, may not be able to meet the criteria set forth in this manual. In such cases, an application for a deviation from the criteria shall be submitted to the appropriate TDOT Regional TSMO Manager.

Single-family residential, two-family residential, and field entrance driveways are exempt from the formal deviation application process when spacing criteria is not met, however, all driveways will be subject to review and approval by the appropriate TDOT Regional TSMO Manager .

Deviation Application for Residential and Commercial Driveway Permits

For driveways, entrances, intersections, and median openings (new or to be relocated) proposed for private sector land development projects that do not meet all spacing or geometric requirements laid out in this manual, an application for a deviation shall be required. TDOT form *HSAM-1 Deviation Request* shall be completed and submitted to the appropriate TDOT Region TSMO Manager. A completed and approved deviation form shall be required in order to obtain a state highway entrance permit.

Deviation Application for Highway Design Projects

For highway construction or reconstruction projects on roadways owned and maintained by TDOT that do not meet the spacing requirements or design criteria of this manual, a deviation application shall be required. TDOT form *HSAM-2 Deviation Request* shall be completed and submitted to the appropriate TDOT Region Traffic Engineering Design Office.

When geometric design criteria from TDOT Standard Drawings, TDOT *Roadway Design Guidelines* or criteria not contained within this manual cannot be met, refer to *TDOT Design Guidelines* for the appropriate exception and waiver forms and process.

Mitigation

Prior to seeking approval for a deviation from the access manual criteria, consider potential strategies to eliminate or mitigate impacts to the corridor. These strategies include, but are not limited to:

- Limiting access points to right-in / right-out, J-Turn or other restricted access configurations.
- Consider use of frontage or backage roads to consolidate access.
- Consider joint access driveways to consolidate access.
- Reduction in number of driveways for properties with multiple access points.
- Limit corner lot access to the minor roadway.

Additional information concerning implementation and functionality of these strategies can be found in Highway System Access Manual (HSAM) Volumes 1 and 2, respectively.

Approval

All requests and forms for a deviation from criteria within the HSAM shall be provided to the appropriate TDOT Region Traffic Operations Office. Once reviewed by the Regional TSMO Manager potentially acceptable requests shall be forwarded to the State Traffic Design Director's Office at TDOT Headquarters to grant or deny the deviation application based on the majority decision reached by a panel of transportation professionals with knowledge relevant to the unique conditions of the requested deviation. The Region Traffic Operations Office submitting the request will then be notified of the decision and the Region Traffic Operations Office will in turn notify the applicant.

Considerations for Private Development

Traffic Impact Studies

For private development or redevelopment jobs that could directly or indirectly impact the State Highway System, a Traffic Impact Study may be required. A Traffic Impact Study is an assessment which determines the expected traffic and safety implications relating to a new or redeveloped property. The level of required study will be dependent upon the size and type of development of the property being studied. Refer to the [Traffic Studies Guidance](#), for all details concerning the Traffic Impact Study process and the information required for completion. A IIE Evaluation as per Volume 2 of this manual may be required.

Highway Entrance Permits

Under State Law, a permit is required before construction of a driveway on state highway right-of-way, including the modification, revision, or change in use of any existing driveway facilities. Property owners must obtain a permit from TDOT.

The purpose of the driveway permit process is to manage access on the State Highway System. Access regulations are necessary to preserve the functional integrity of the State Highway System and to promote the safe and efficient movement of people and goods while providing reasonable access to adjoining property owners.

Refer to [TDOT's Website on Highway Entrance Permits](#) for all resources required to apply for and obtain a Highway Entrance Permit.

References

AASHTO. (2018). *A Policy on Geometric Design of Highways and Streets*, (7th ed.). Washington, D.C.: AASHTO.

Florida Department of Transportation. (2014). *Median Handbook*.

NCHRP. (2001). *Report 457, Evaluating Intersection Improvements: An Engineering Study Guide*. Washington, D.C.: National Academy Press.

NCHRP. (2010). *Report 659, Guide for the Geometric Design of Driveways*. Washington, D.C.: National Academy Press.

NCHRP. (2013). *Report 745, Left-Turn Accommodations at Unsignalized Intersections*. Washington, D.C.: The National Academies Press.

NCHRP. (2018). *Report 855, An Expanded Functional Classification System for Highways and Streets*. Washington, D.C.: The National Academies Press.

The University of Tennessee, Knoxville, Center for Transportation Research. (2017). *Access Management Report*.

Transportation Research Board. (2014). *Access Management Manual*. (2nd, Ed.) Washington, D.C.

Virginia Department of Transportation. (Rev. 2014). *Road Design Manual, Appendix F, Access Management Design Standards for Entrances and Intersections*.

Appendix

Appendix A - Driveway Horizontal Geometry Example Figures

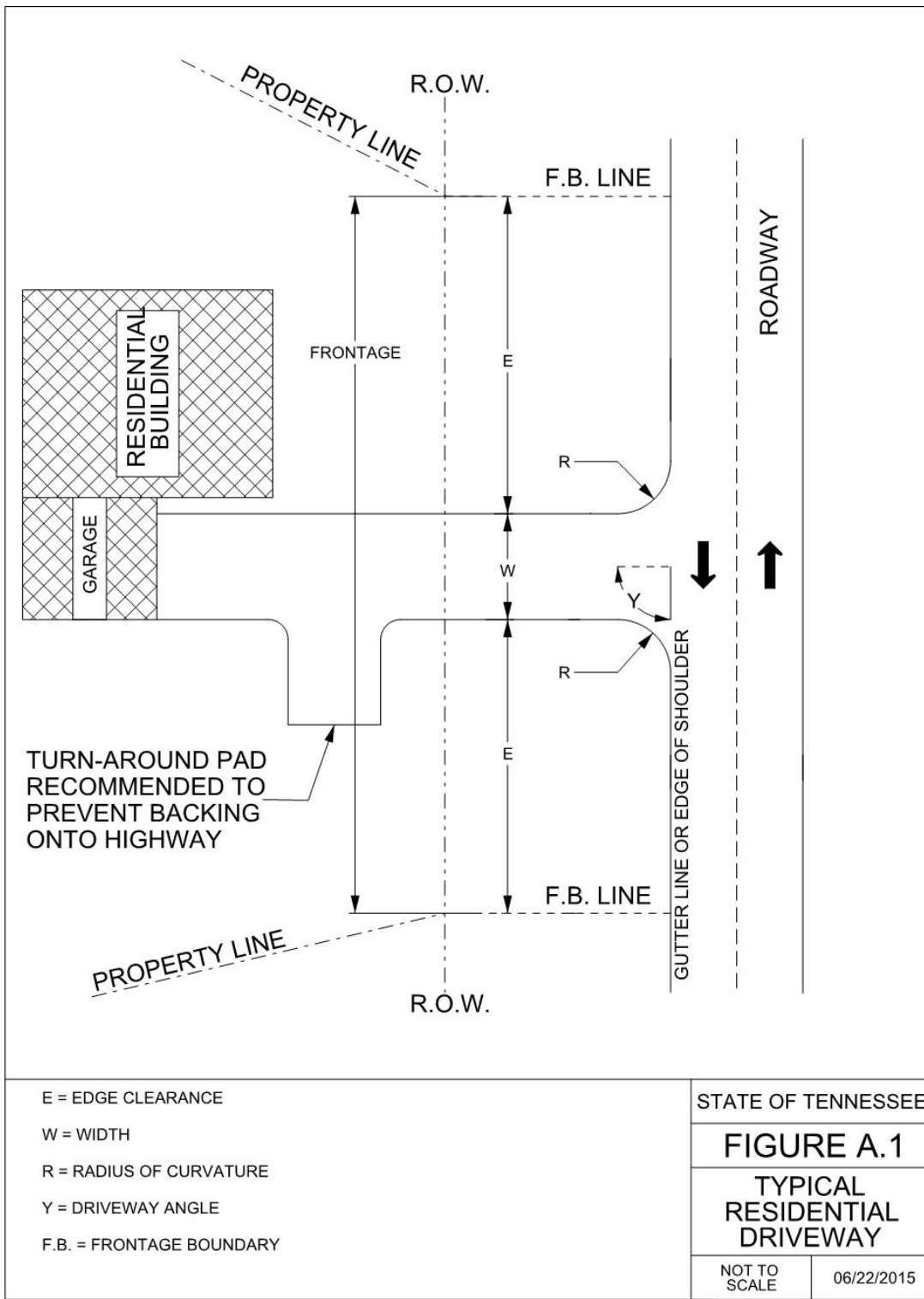

Figure A.1: Typical Residential Driveway

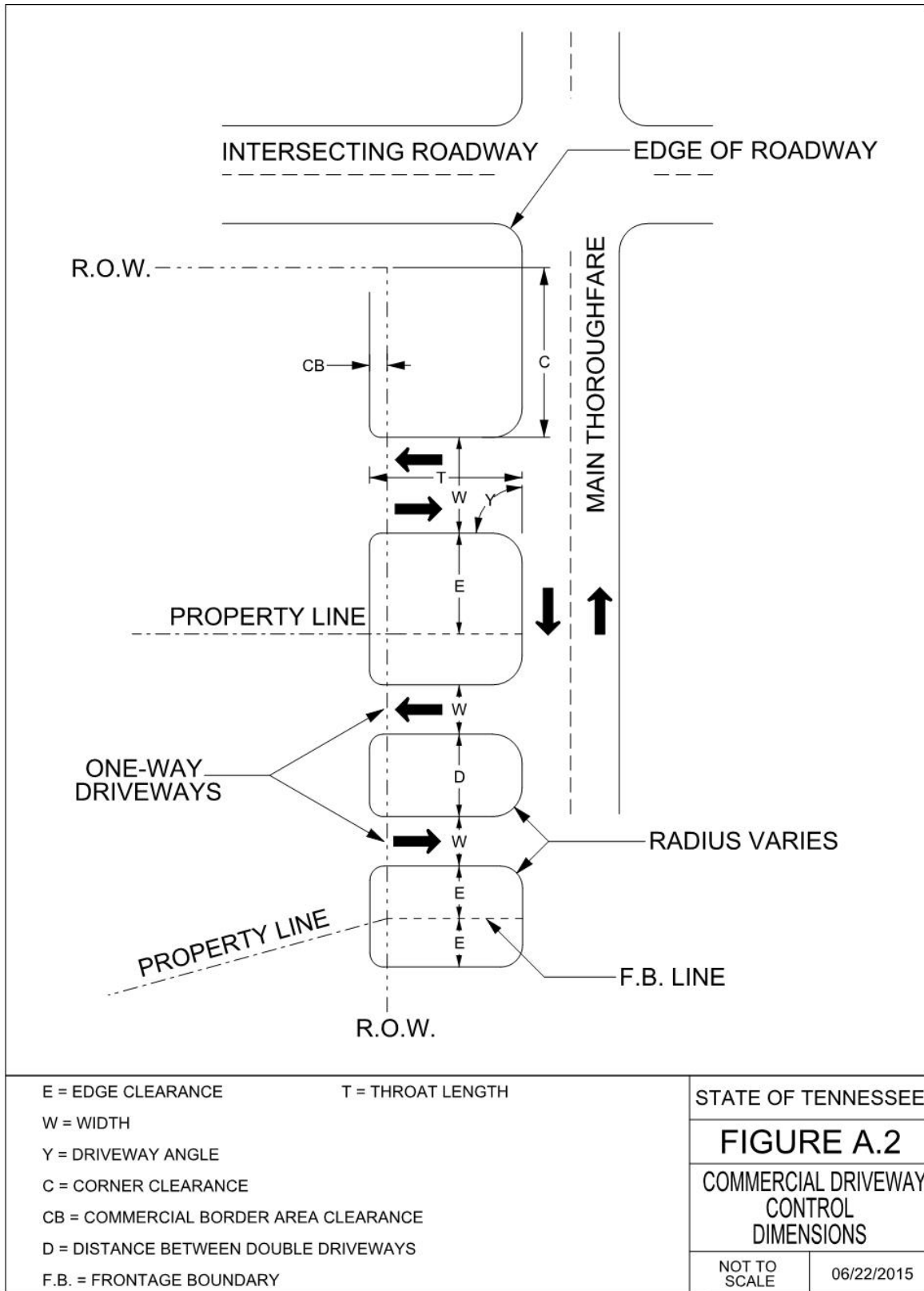

Figure A.2: Commercial Driveway Control Dimensions

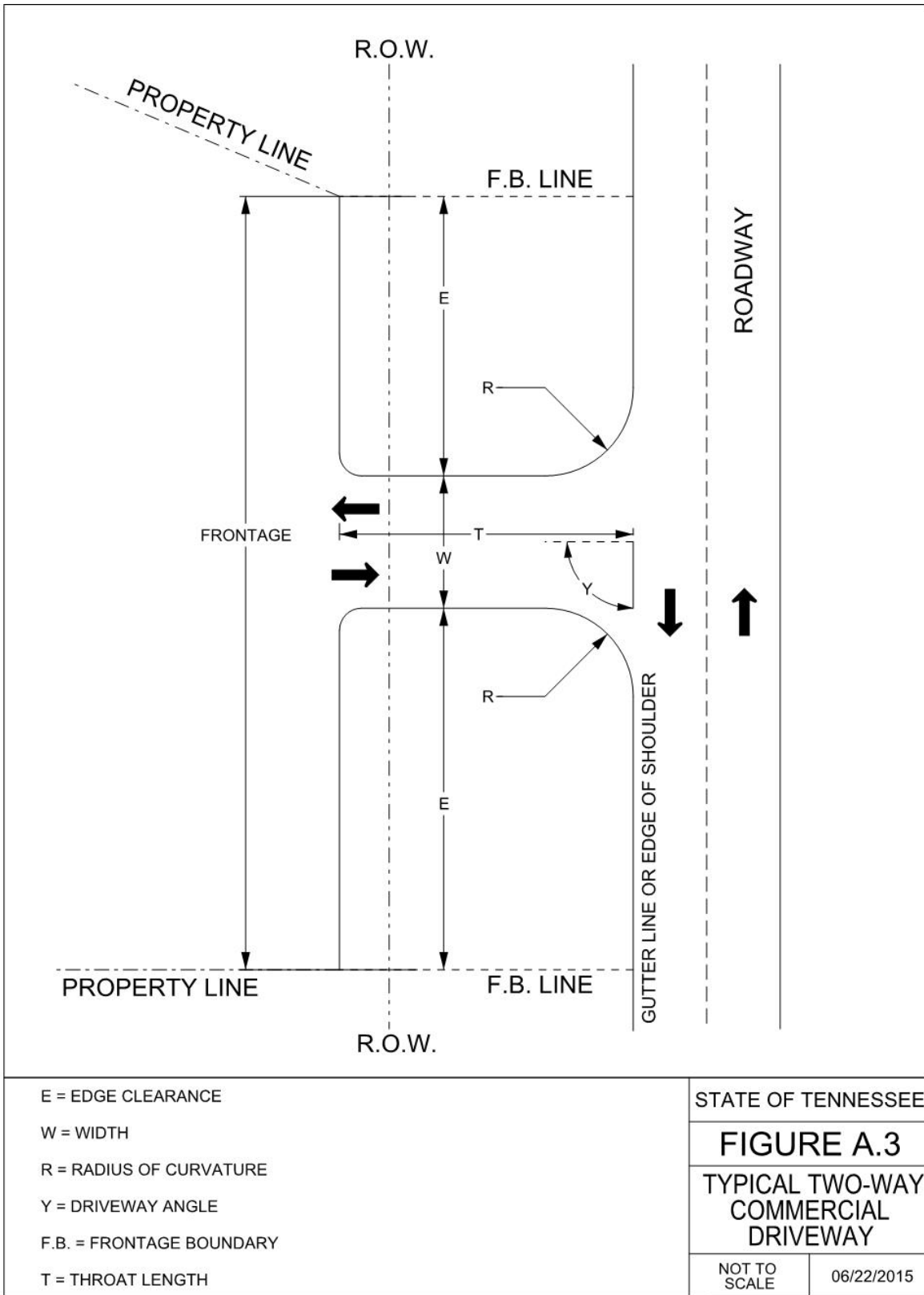

Figure A.3: Typical Two-Way Commercial Driveway

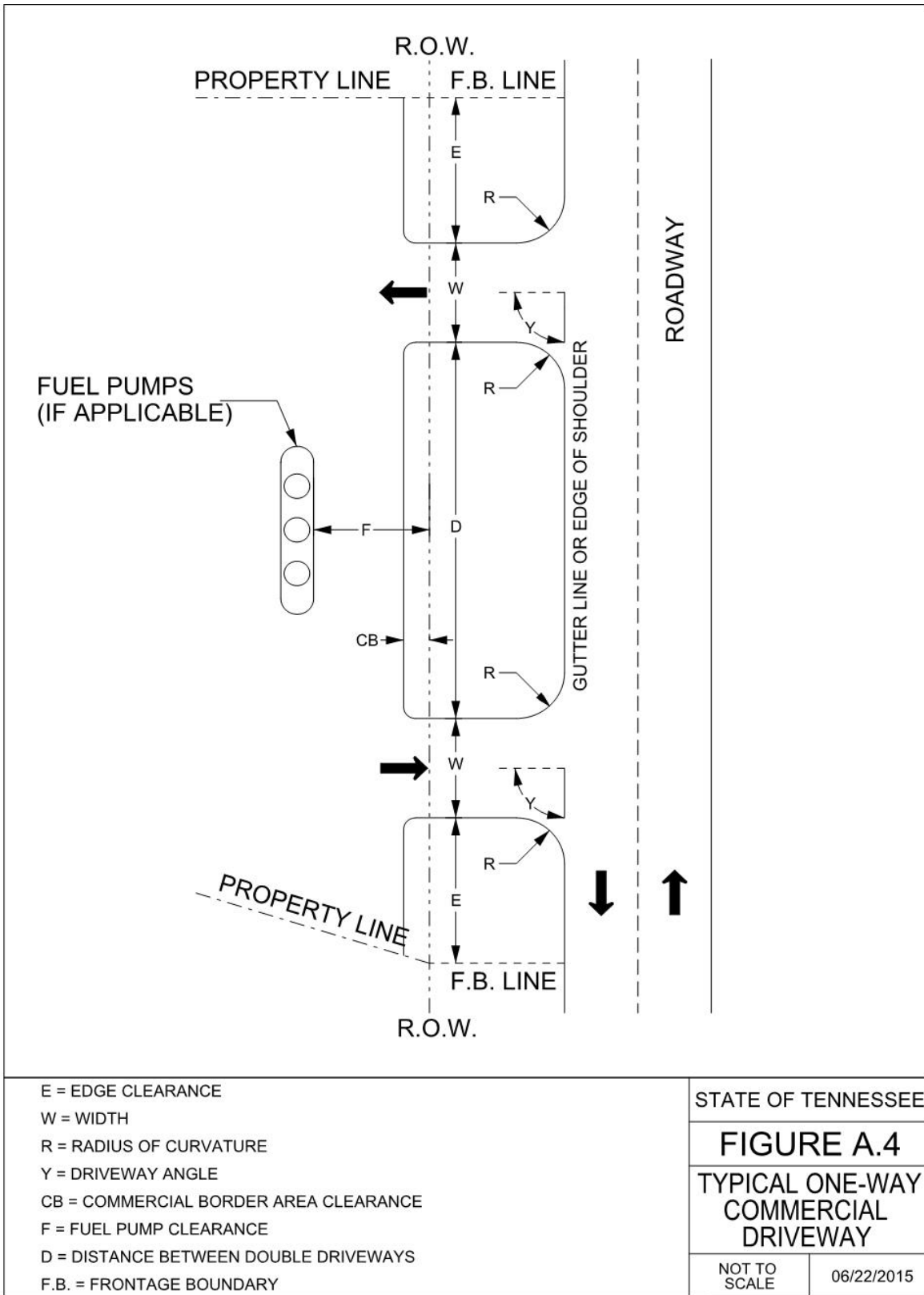

Figure A.4: Typical One-Way Commercial Driveway

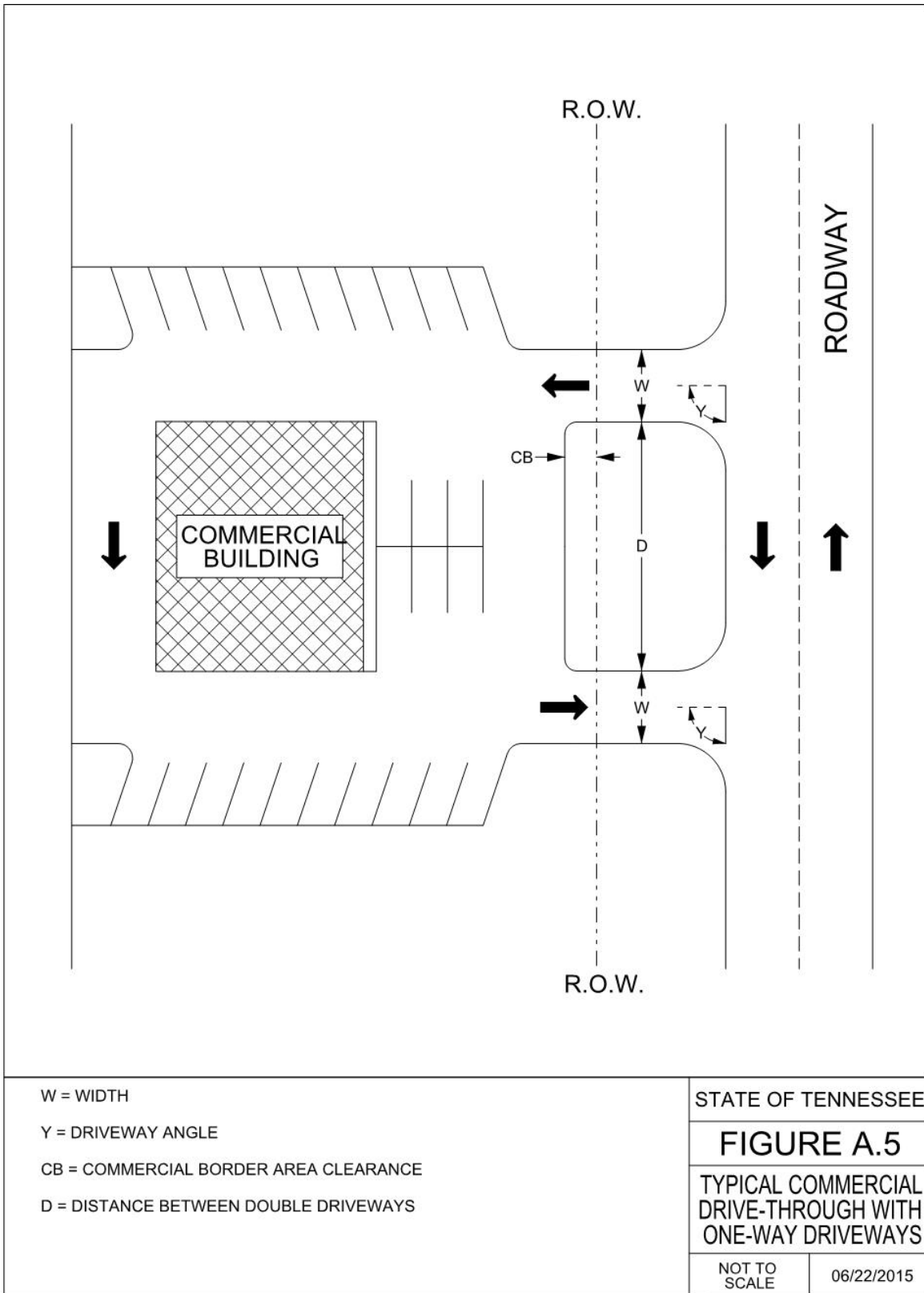

Figure A.5: Typical Commercial Drive-Through with One-Way Driveways

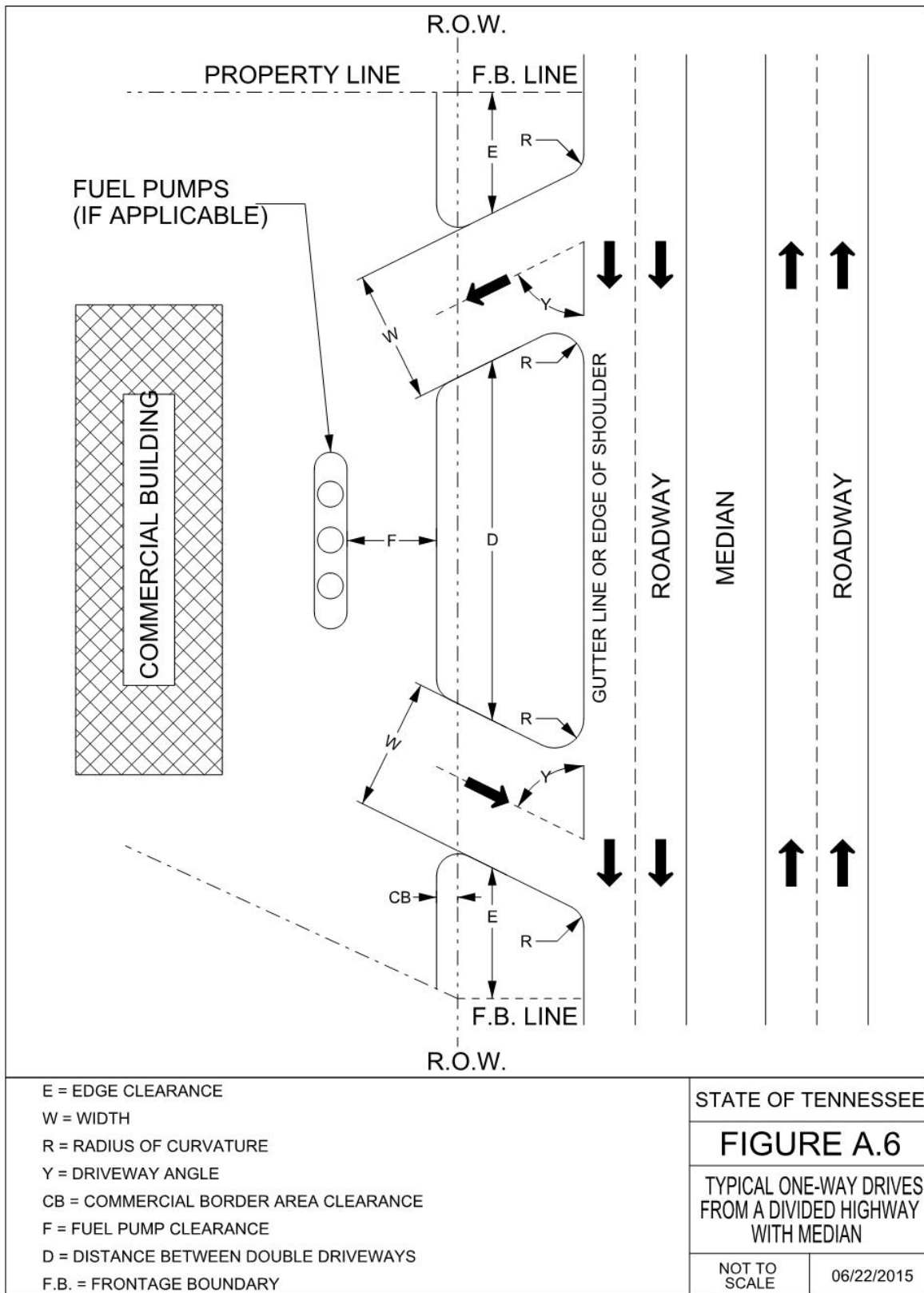

Figure A.6: Typical One-Way Drives from a Divided Roadway with Median

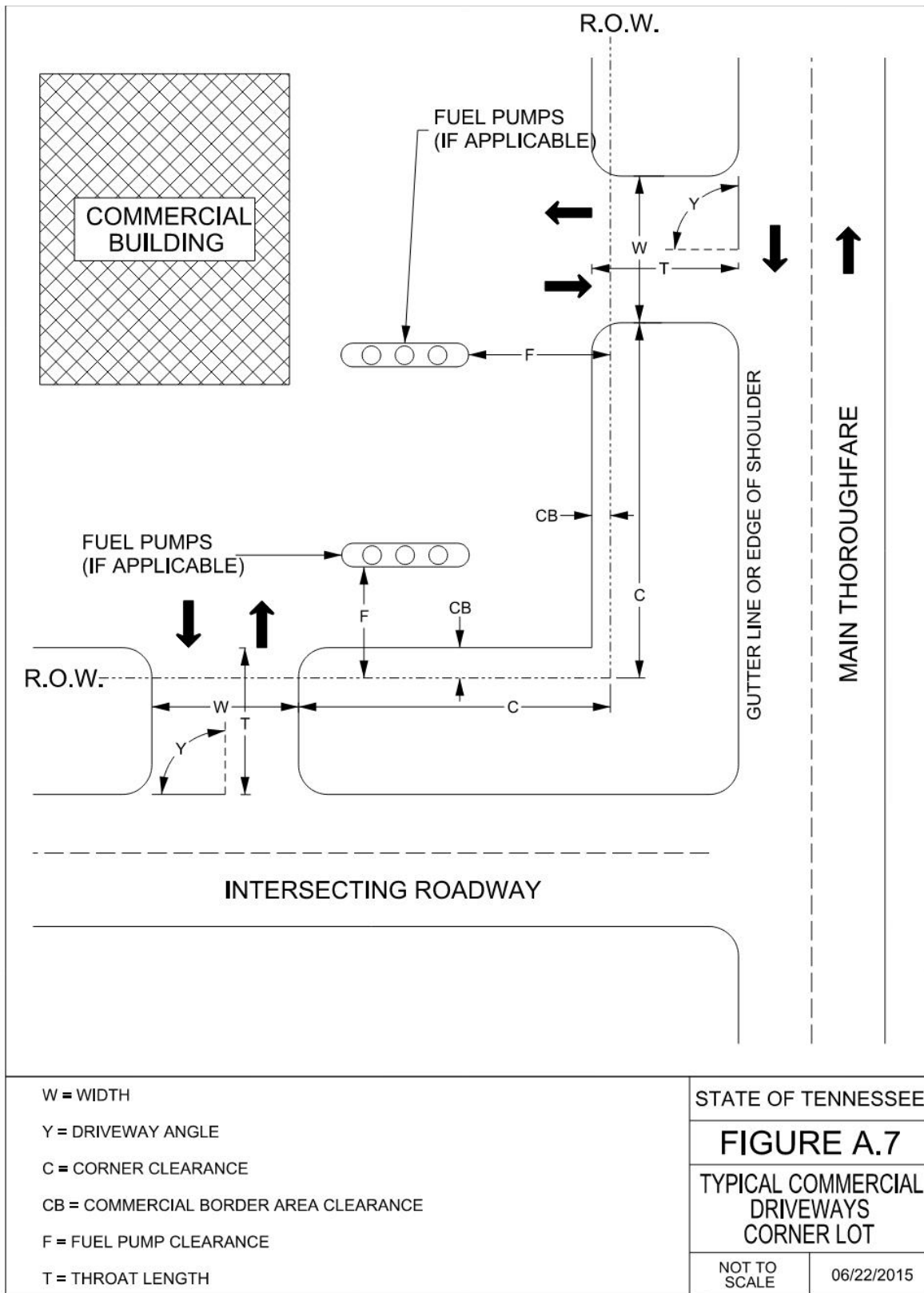

Figure A.7: Typical Commercial Driveways Corner Lot

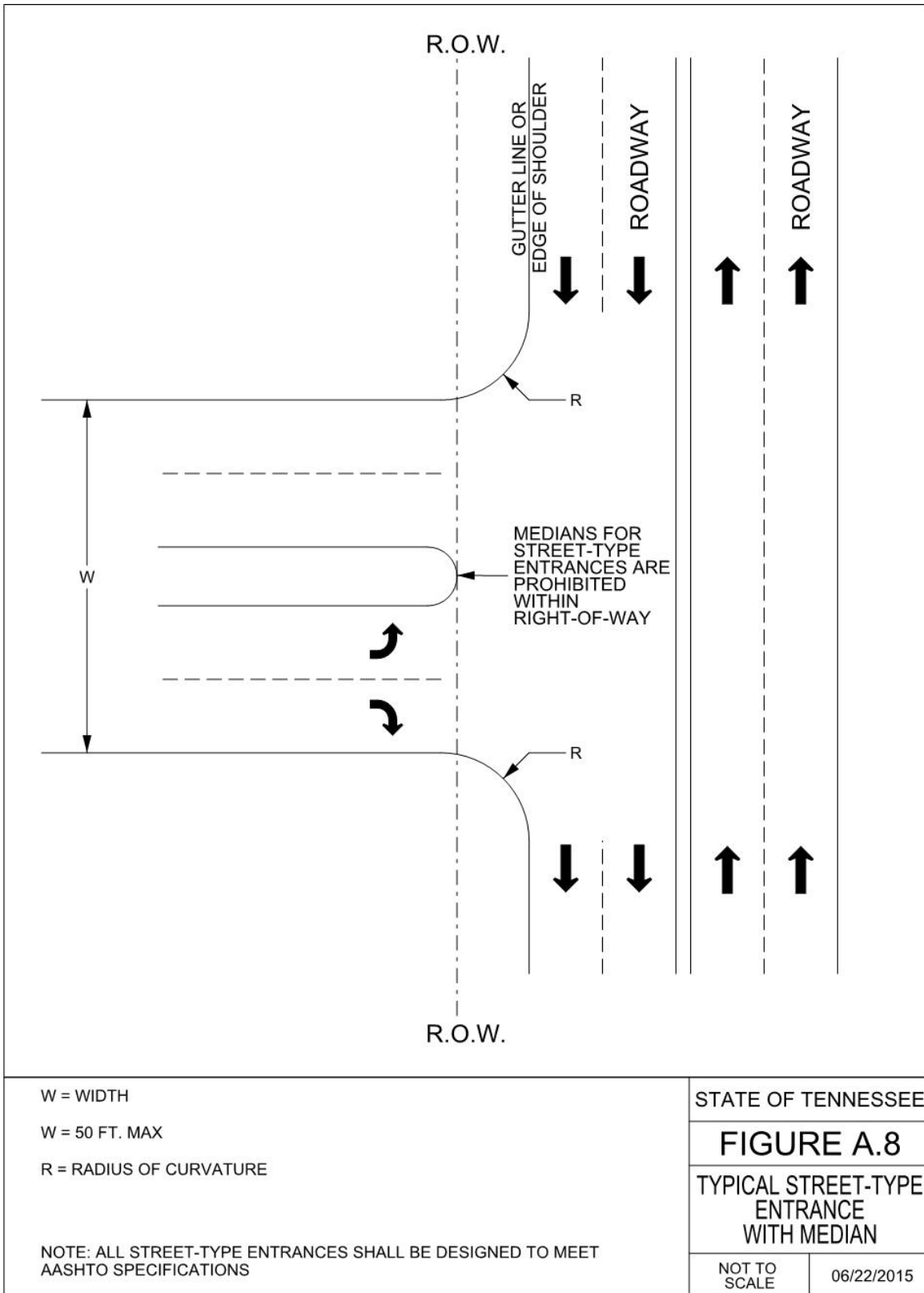

Figure A.8: Typical Street-Type Entrance with Median

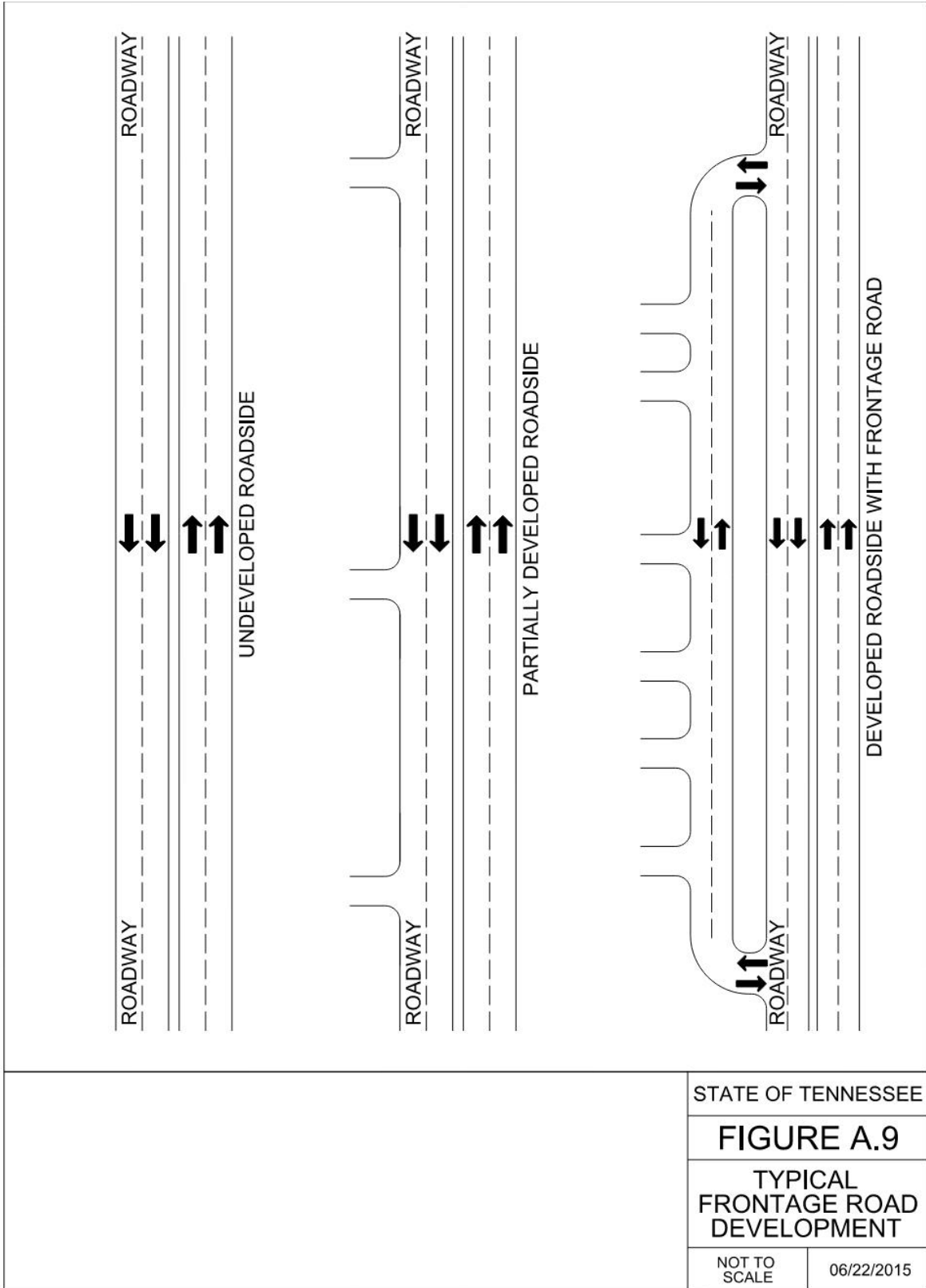

Figure A.9: Typical Frontage Road Development

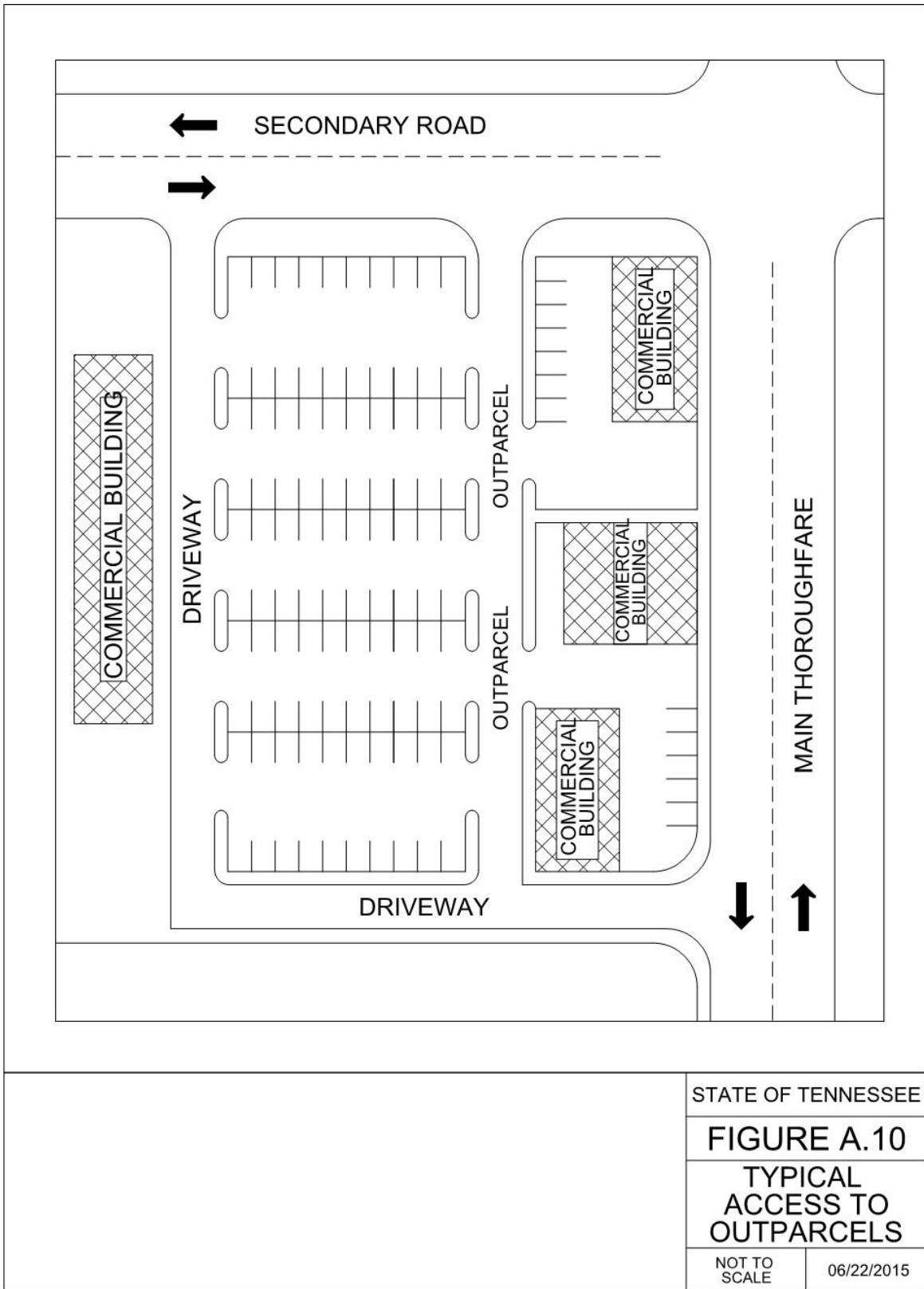
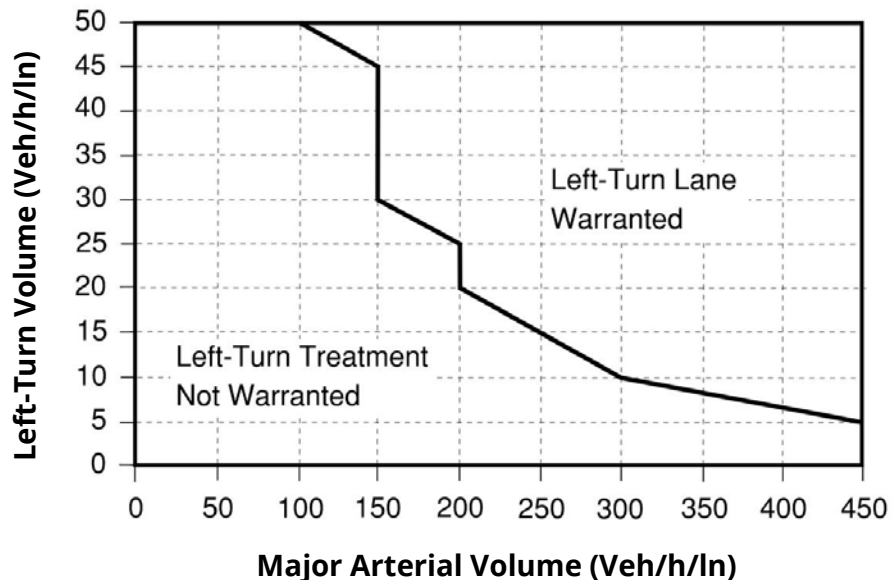
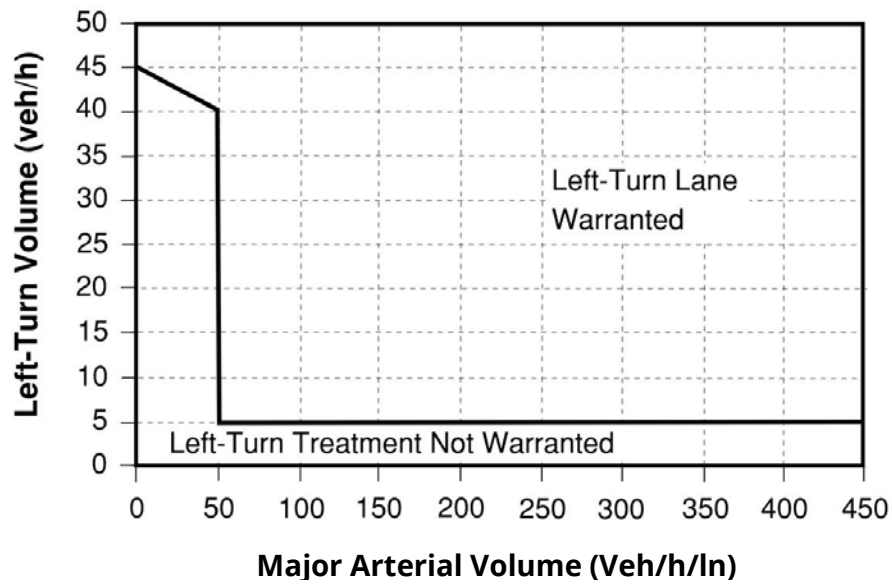

Figure A.10: Typical Access to Outparcels

Appendix B – Turn Lane Warrants



(a) Three-Leg Intersections



(b) Four-Leg Intersections

STATE OF TENNESSEE	FIGURE B.1
LEFT-TURN LANE WARRANT FOR URBAN AND SUBURBAN ARTERIALS (UNSIGNALIZED)	

Figure B.1: Left-Turn Lane Warrant for Urban and Suburban Arterials (Unsignalized)

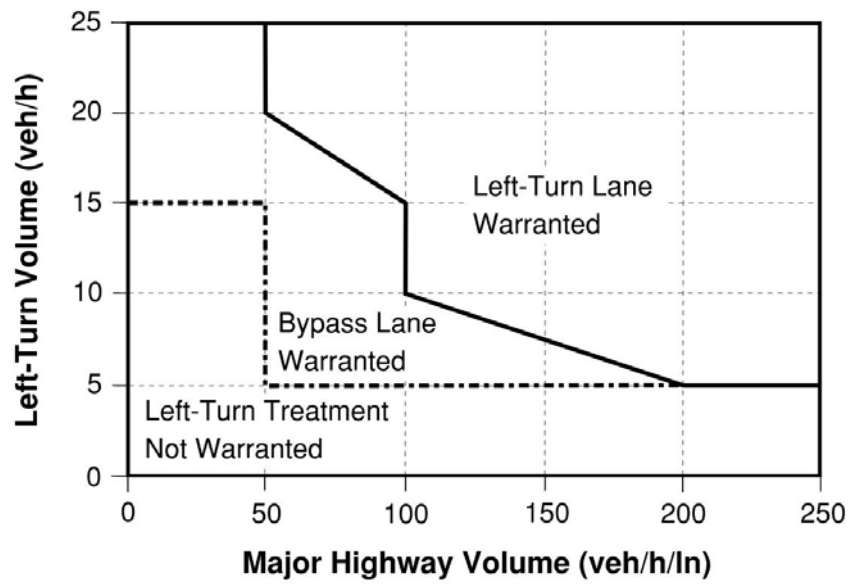

(a) Three-Leg Intersections

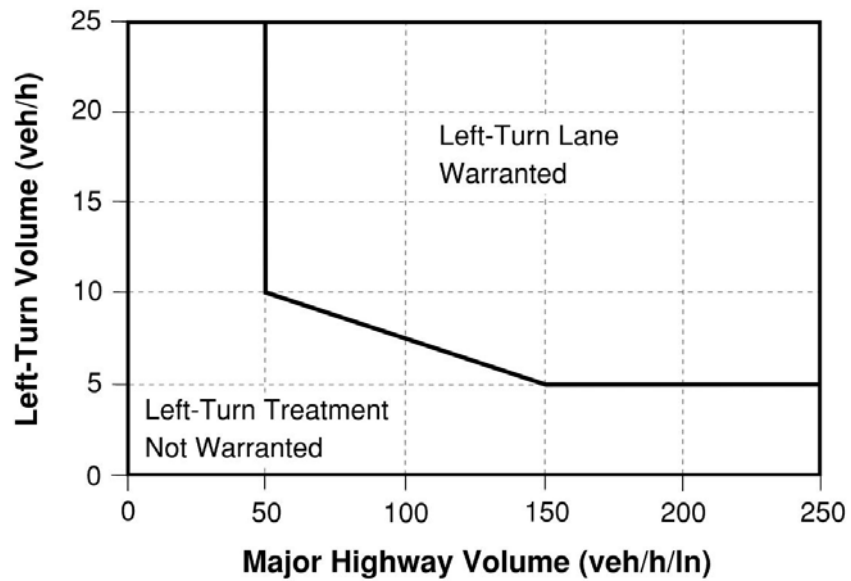

(b) Four-Leg Intersections

STATE OF TENNESSEE	FIGURE B.2
LEFT-TURN LANE WARRANT FOR TWO-LANE RURAL HIGHWAYS (UNSIGNALIZED)	

Figure B.2: Left-Turn Lane Warrant for two-Lane Rural Roadways (Unsignalized)

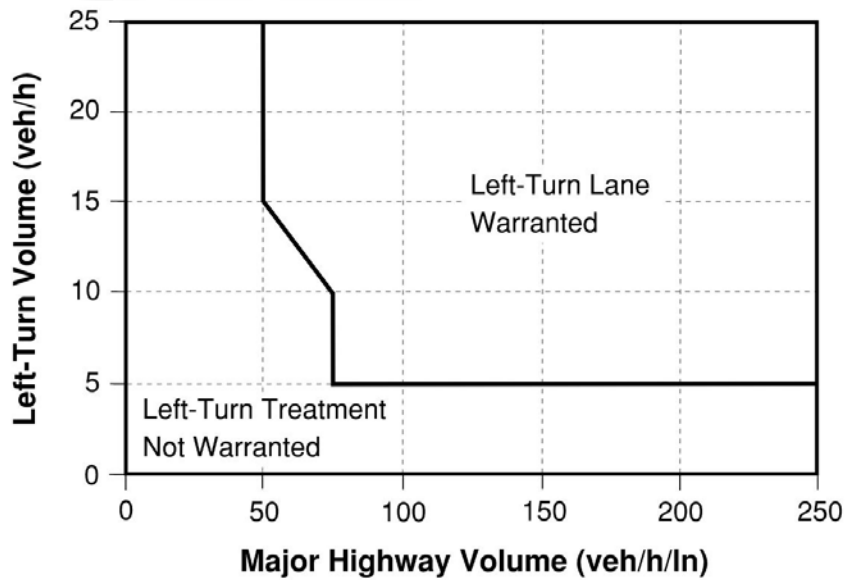

(a) Three-Leg Intersections

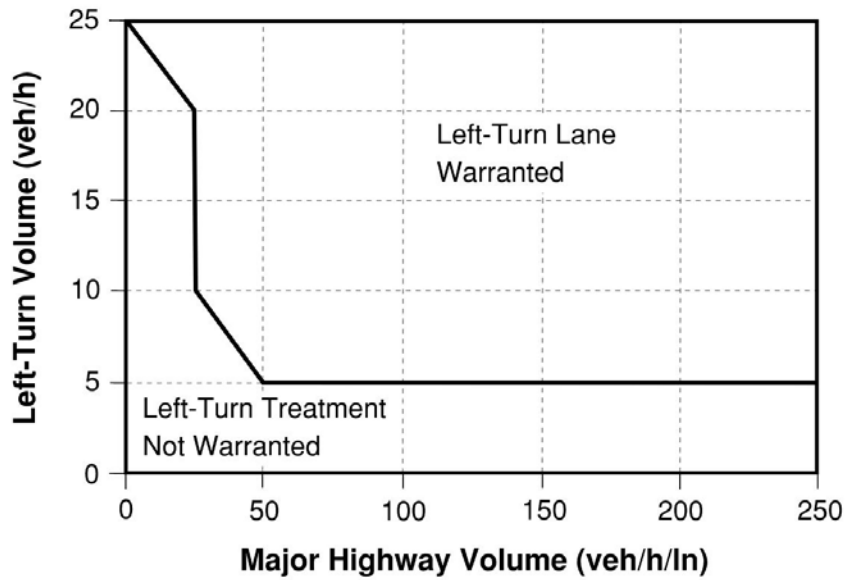

(b) Four-Leg Intersections

STATE OF TENNESSEE	FIGURE B.3
LEFT-TURN LANE WARRANT FOR FOUR-LANE RURAL HIGHWAYS (UNSIGNALIZED)	

Figure B.3: Left-Turn Lane Warrant for Four-Lane Rural Roadways (Unsignalized)

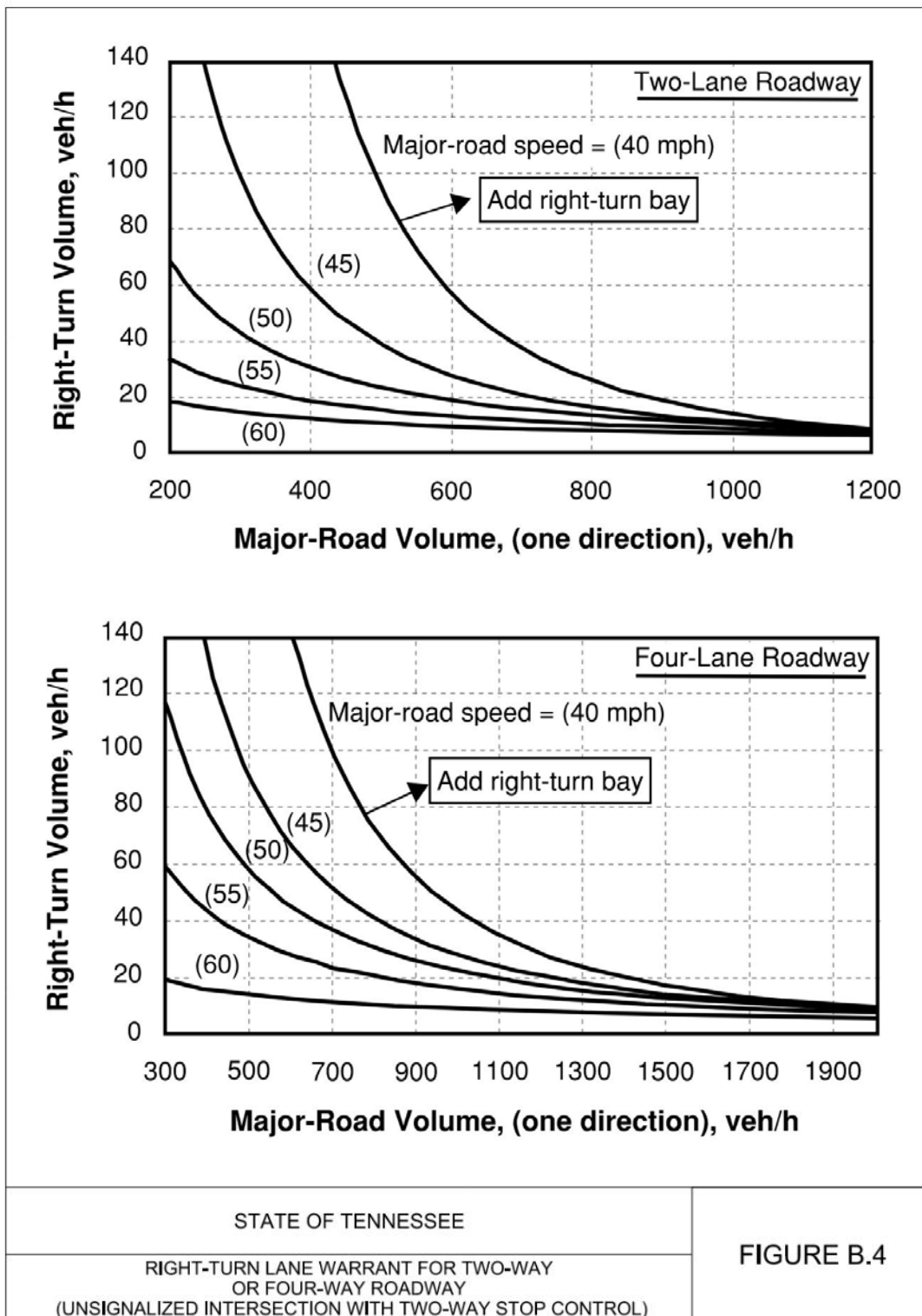

Figure B.4: Right-Turn Lane Warrant for Two-Way or Four-Way Roadway (Unsignalized Intersection with Two-Way Stop Control)