



SDG 6:

Steel Girders

Chapter 6

Tennessee Department of Transportation October 7, 2024



Table of Contents

Section 1 Introduction	1
Section 2 Design Specifications and Design Programs.....	1
Section 3 Minimum Level of Analysis	1
Section 4 Span Arrangement and Uplift	2
Section 5 Phased Construction	2
Section 6 Existing Bridge Widening.....	2
Section 7 Steel Grade Selection.....	3
Section 8 Girder Spacing and Shipping	4
Section 9 Haunch Thickness	5
Section 10 Flanges.....	5
Section 11 Webs	7
Section 12 Fatigue Design	7
Section 13 Intermediate Stiffeners	7
Section 14 Bearing Stiffeners.....	7
Section 15 Cross-Frames and Diaphragms.....	8
Section 16 Bolted Connections.....	9
Section 17 Tab Connection Plates.....	10
Section 18 Longitudinal Stiffeners	10
Section 19 Shear Connectors.....	10
Section 20 Lateral Bracing.....	10
Section 21 Stress Limit for Tension Flanges	11
Section 22 Dead Load Correction Curve	12
Section 23 Paint	12
Section 24 Faying Surfaces.....	12
Section 25 Web-to-Flange Welding.....	12
Section 26 Deflection Check for Slab Pouring Sequence.....	13
Section 27 Cantilever Bracket Rotation.....	13

Section 28 Cover Plates 13
Section 29 Stain Prevention 13
Appendix A: Additional Design Information 15
Appendix B. Standard Details 18
Version History and Revision Summary 21

Table of Figures

Figure 1. Partial Framing Plan 11
Figure 2. Standard Details for Cross-Frames and Lateral Bracing 19
Figure 3. Standard Details for Cross-Frames, Stiffeners, Tab Connection Plates, and Stringers..20

List of Tables

Table 1. Minimum Level of Analysis 2
Table 2. Version History and Revision Summary 21

Section 1 Introduction

Steel girders have been used for bridges in Tennessee for many decades. They are typically used for bridges when prestressed beams are not an option due to long span lengths or superstructure depth limitations. Steel girders are more expensive than prestressed beams, but they can reduce the overall bridge cost by the reducing the number of foundations required in certain applications.

The majority of steel girders in Tennessee are I-shaped plate girders. Rolled girders are a good option for shorter spans within their applicable span range. Rolled girders can be more economical than plate girders because of decreased fabrication costs. TDOT has a rolled girder made continuous option designed to compete with bulb-tee beams for spans between 100 feet and 140 feet.

Steel tub girders have been used for a small number of bridges in Tennessee. They are more expensive than I-shaped girders and more difficult to design. Steel tub girders shall not be used without the permission of the Director.

Section 2 Design Specifications and Design Programs

Use the current edition of the AASHTO LRFD Bridge Design Specifications.

All steel girders shall be designed using Leap Bridge Steel unless approval to use an alternate program is given by the Design Manager. The computer program chosen to be used for the design check shall require approval by the Design Manager.

Section 3 Minimum Level of Analysis

The minimum level of analysis shall not be less than the level given in Table 1. The skew angle is measured between the centerline of survey and the centerline of the substructures.

Girder Type	Skew	Minimum Level of Analysis
Straight	70° to 90°	1D Line Girder
	Less than 70°	2D Grillage
Curved	90° (Radial)	2D Grillage

Table 1. Minimum Level of Analysis

Curved steel bridges shall have radial substructures. Skewed substructures shall not be permitted for curved steel bridges. Chorded straight steel girders (kinked girders) for curved bridges shall not be permitted.

Section 4 Span Arrangement and Uplift

End spans shall have sufficient length so that the abutment reactions at the Strength 1 limit state are positive (no uplift) unless otherwise approved by the Director.

Always consider the presence of uplift at the ends of continuous girders, particularly with short end spans. AASHTO C3.4.1 indicates uplift is to be checked as a strength load combination and provides guidance in the appropriate use of maximum and minimum load factors.

Section 5 Phased Construction

Phased construction of curved girders shall be avoided if possible. Phasing of curved girders is a problematic issue and shall be discussed in detail with the Director. Phased cambers will not be correct, and the cross-slope of each phase will not match the required cross-slope for the full slab width. A closure pour cannot correct this problem. Phased construction of straight and curved steel girder bridges shall always have a closure pour.

Section 6 Existing Bridge Widening

Widenings of existing bridges shall be done in accordance with the following:

Widening of existing bridge **with** closure pour between proposed and existing girders (2 or more adjacent proposed girders on one or both sides):

- Initial bracing between the proposed and existing bridge for straight girders shall be the cross-frame top chord and bottom chord with one bolt* at each end of the chord. The remaining bolts and diagonal cross-frame members shall be installed and all bolts tensioned to the required value after the slab closure pour is completed. (*Engineer shall verify the sufficiency of chords and single bolts to resist lateral displacement of the compression flange and construction wind load.)

Widening of existing bridge **without** closure pour between proposed and existing girder (1 proposed girder on one or both sides):

- Designer shall investigate the use of needle beams.

Widening of curved girder bridge **without** complete slab removal:

- Widening of curved girder bridges is a problematic issue and shall be discussed in detail with the Director.

Widening of existing bridge **with** complete slab removal:

- All cross-frame members shall be installed and all bolts shall be tensioned to the required value prior to the slab pour.

Section 7 Steel Grade Selection

Weathering steel is the most common type of steel used for new bridges in Tennessee. Although weathering steel is slightly more expensive initially than non-weathering steel, it is ultimately more economical because it does not require initial or maintenance painting. However, if the bridge site meets one or more of the conditions below, non-weathering steel shall be used instead of weathering steel.

- If the atmosphere contains concentrated corrosive industrial or chemical fumes.
- If the steel is used for a low urban-area bridge or overpass that creates a tunnel-like configuration over a road on which deicing salt is used. In this situation, road spray from traffic under the bridge causes salt to accumulate on the steel.

- If the structure provides low clearance (less than 8 to 10 feet) over stagnant or slow-moving water.

The default steel grade is ASTM A709 Grade 50W. ASTM A709 Grade HPS50W is a high-performance steel and may find application in fracture critical members.

All non-weathering steel girders shall be painted. When non-weathering steel is used, the default steel grade is ASTM A709 Grade 50 for plate girders and Grade 50S for rolled shapes.

Hybrid girders are permitted with the approval of the Design Manager. Hybrid girders use ASTM A709 Grade HPS70W steel in specific areas only, such as over the piers and at midspan. Hybrid girders can be helpful for bridges when the designer needs to reduce the girder weight for a specific reason, such as limited crane access to the site due to environmental restrictions. Despite having higher yield and tensile strengths, Grade HPS70W steel offers no additional stiffness over lower grade steels, and deflections and camber shall be evaluated to determine if they are acceptable.

The use of A709 Grade 100 or 100W steel is not permitted. These steel grades have had no practicable application to date for TDOT bridges.

Section 8 Girder Spacing and Shipping

Girder spacing shall be limited to 12 feet to accommodate typical stay-in-place (SIP) metal deck form configurations and to avoid slab thicknesses exceeding the standard 8.25 inches unless approval is given by the Design Manager. Girders with stringer girders mounted on cross-frames often have girder spacings exceeding 12 feet. This is an option that shall be restricted to major bridges and experienced designers.

The maximum field section length is 150 feet unless shipping by barge or train is feasible.

For curved girders, the girder sweep plus the flange width should not exceed 6 feet for ease of shipping. The legal vehicle width limit is 8'-6" without a permit.

The legal vehicle height limit is 13'-6" without a permit. Most trailers are approximately 4 feet high. Assume approximately 6 inches for dunnage. Overall girder depths not exceeding 9 feet promote ease of shipping. However, girders with depths exceeding 12 feet have been used in Tennessee without undue hardship.

Designers shall consult with the Structures Bridge Performance Group when considering the use of girders with dimensions outside these limits.

Section 9 Haunch Thickness

The haunch thickness varies for welded plate girders and is constant for rolled girders. For welded plate girders, the haunch thickness is included in the total dimension from the top of slab to the top of web (at the centerline of the girder) on the “Typical Cross-Section” drawing. This value is constant throughout the bridge length. As the top flange thickness changes, the haunch thickness changes by an equal and opposite amount to maintain a constant dimension from the top of slab to the top of web. For rolled beams, the top flange thickness is constant. The haunch thickness is also constant and is included in the total dimension from the top of slab to the top of the top flange (at the centerline of the girder) on the “Typical Cross-Section” drawing. The haunch thickness shall be set to never be less than the following minimum values:

- 1" minimum at edge of flange for all girders
- 1 ½" minimum at centerline of all girders

The 1-inch minimum thickness along the edge of the top flange makes provision for a 1" thick bituminous fiberboard deck panel support and provides a contingency against encroachment of the beam into the bottom of the deck. (The terms “deck” and “slab” are used interchangeably in this document.)

Section 10 Flanges

The minimum flange width for plate girders is 18 inches. This helps with stability during girder erection.

Maintain a constant flange width for each girder field section where practicable to do so. It is impracticable to do this on bridges with very long spans where the flange plates are very large, particularly in the negative moment regions over interior supports.

All flange width transitions shall be made at field splices unless permission is given by the Design Manager to vary the flange width within a field section. Using a constant flange width for a field section allows the steel fabricator to use a process called “slabbing and stripping.” In this process, wide plates of different thicknesses are welded to each other, and individual flanges are then cut from this assembly. This process results in long, continuous welds which are more efficient than welding each flange splice individually. It also reduces flange plate handling costs in the shop. The fabricator may elect not to “slab and strip” the flanges, and it is not always feasible with curved girders.

Width increments shall be in whole inches.

Flange width affects girder stability during handling, erection, and deck placement. The girder field section length to minimum top flange width ratio shall not exceed 85. See AASHTO C6.10.2.2 for more information.

Flange thickness transitions within field sections are made with full penetration butt welds, which are very expensive. The cost of a flange thickness transition is assumed to be justified if the transition results in a flange weight savings of at least 1,020 pounds. The minimum length of thicker flange required to justify a butt weld, L , is calculated as:

$$\left(\frac{t_{f2} - t_{f1}}{12}\right) \left(\frac{w_f}{12}\right) (L) \left(490 \frac{lb.}{ft.^3}\right) = 1020 lb.$$

$$L = \frac{300}{(t_{f2} - t_{f1})(w_f)}$$

Where:

L = minimum length of thicker flange required to justify a butt weld (ft.)

w_f = flange width (in.)

t_{f1} = thinner flange thickness (in.)

t_{f2} = thicker flange thickness (in.)

Example:

$t_{f1} = 1.5$ in.

$t_{f2} = 2.25$ in.

$w_f = 18$ in.

$$L = \frac{300}{(2.25 \text{ in.} - 1.5 \text{ in.})(18 \text{ in.})} = 22.2 \text{ ft.}$$

Therefore, if the 2.25-inch flange was to be extended by 22.2 feet or more, then the butt weld would be cheaper than the extra cost of the extended 2.25-inch flange. Stated another way, if the 2.25-inch flange was not extended at least 22.2 feet, then it would be cheaper to extend it rather than transition to the 1.5-inch flange using a butt weld.

The maximum allowable flange thickness is 4 inches. This is the maximum available plate thickness for the allowable grades of steel.

The minimum flange thickness for plate girders is 1 inch. Thinner plate is subject to excessive distortion from welding.

Use flange thickness increments of ¼-inch from 1 to 3 inches, and ½-inch from 3 to 4 inches. The smaller flange at flange transitions shall have a cross-sectional area not less than half that of the larger flange.

Section 11 Webs

The minimum allowable web thickness for plate girders is ½-inch. Thinner plate is subject to excessive distortion from welding.

Use web thickness increments of 1/16-inch up to a plate thickness of 1-inch. Use 1/8-inch increments for thicker web plates.

The need for more than one web thickness is rare and shall only be permitted with the approval of the Design Manager. In the case of very large girders, employing webs of different thicknesses or grades of material may be warranted.

Web dapping is not allowed except with the approval of the Director.

Section 12 Fatigue Design

All steel girders, including all steel details, shall be designed for an infinite fatigue life (Fatigue 1 load combination.)

Section 13 Intermediate Stiffeners

The minimum allowable intermediate stiffener thickness is ½-inch.

Intermediate stiffeners not serving as cross-frame connection plates shall be tight fit against the top and bottom flanges. Intermediate stiffeners serving as cross-frame connection plates shall have tab connection plates at the top and bottom flanges for multi-span bridges and at the bottom flange for single span bridges. Intermediate stiffeners serving as cross-frame connection plates for single span bridges shall be welded to the top flange.

Section 14 Bearing Stiffeners

The minimum allowable bearing stiffener thickness is ½-inch.

Bearing stiffeners shall have a finish-to-bear fit with fillet welds at the bottom flange. They shall be tight fit with tab connection plates at the top flange. Fabricators discourage full-penetration welding of bearing stiffeners to flanges because full-penetration welds may distort the bearing area of the bottom flange.

Bearing stiffeners shall extend to within $\frac{1}{2}$ -inch to $\frac{3}{4}$ -inch from the flange edge. If a wider stiffener is required to facilitate bolting of cross-frame or diaphragm members, taper the stiffener from the flange to the desired width.

Bearing stiffeners shall have sufficient thickness to avoid the need for multiple bearing stiffeners at any given bearing. Multiple stiffeners present fabrication difficulties and usually are not needed.

Section 15 Cross-Frames and Diaphragms

Cross-frame members shall consist of either angles or WT shapes. Diaphragms shall consist of a channel or bent plate. See AASHTO 6.7.4.2 for depth requirements. Cross-frame configurations routinely used by TDOT are Z-frames and K-frames. W-frames have application in rare instances where the girder spacing to depth ratio is unusually large. Z-frames shall not be permitted for curved girders. X-frames without top and bottom chords shall not be permitted.

Design and detail cross-frames such that they can be erected as a single unit. Shipping straps are often used to accomplish this end. If shipping straps are to be removed after the cross-frames are installed, this needs to be noted on the bridge plans.

All connections between cross-frames/diaphragms and girders shall be bolted.

Oversized or slotted holes are not permitted. The use of standard size bolt holes helps control the geometry.

The cross-frame/diaphragm spacing shall not exceed 25 feet.

Cross-frames/diaphragms at supports shall be investigated to ensure adequate capacity to convey lateral wind and seismic loads to the substructure.

Placing all cross-frames/diaphragms along the skew is acceptable for skews of 70 degrees and greater. All other cross-frames/diaphragms shall be normal to the girders. Curved girders are an exception and shall always have radial cross-frames/diaphragms at intermediate locations.

Section 16 Bolted Connections

Use ASTM F3125 Grade A325 bolts unless Grade A490 bolts are required by design. For tab plate connections, Grade A325 bolts are used for straight girders and Grade A490 bolts are used for curved girders. When specifying bolts, use the following designations:

- For weathering steel, use either ASTM F3125 Grade A325 Type 3 or ASTM F3125 Grade A490 Type 3.
- For non-weathering steel, use either ASTM F3125 Grade A325 Type 1 or ASTM F3125 Grade A490 Type 1.

A490 bolts are much more sensitive to tightening procedures. If over-tightened, these bolts can unload significantly below their proof load. A325 bolts have much more ductile behavior, so they can be tightened well beyond their proof load and still maintain the required tension.

Ungalvanized A325 bolts can be retightened, but all A490 bolts cannot and must be replaced. There is the potential for Contractors to loosen and retightening bolts in the field. Using ungalvanized A325 bolts relieves TDOT inspectors from ensuring that loosened A490 bolts are replaced.

If A490 bolts are necessary, use them in all similar connections or make them a different diameter than the A325 bolts used for the bridge. For example, if A490 bolts are required for some lateral bracing connections, use the same size A490 bolts for all lateral bracing connections.

One-inch and 7/8-inch diameter bolts shall be the only sizes considered for bridges with preference given to 1-inch bolts for all major structural connections. One-inch bolts often provide the most economical design. However, for small, rolled girder flanges, smaller bolts may be better due to net area requirements. Do not mix sizes within a splice, cross-frame, etc.

Provide more edge distance for bolt holes than the AASHTO minimums. If the drill drifts during the drilling operation, the hole could violate minimum edge distances. Add at least a 1/4-inch contingency to the AASHTO minimum edge distances given in AASHTO Table 6.13.2.6.6-1.

Use galvanized bolts on field connections of bridge members when ASTM F3125 Grade A325 (or A490) Type 1 bolts are specified, and the steel is painted. Galvanized A325 (or A490) Type 1 bolts shall not be retightened. Use ASTM F3125 Grade A325 (or A490) Type 3 bolts with weathering steel.

Section 17 Tab Connection Plates

Tab connection plates shall be provided at the top and bottom flanges for all intermediate stiffeners serving as cross-frame connection plates (see Section 13.) Tab connection plates shall be provided at the top flange for bearing stiffeners serving as cross-frame connection plates (see Section 14.)

Single tab connection plates extending between the stiffener and the flange shall not be permitted.

Section 18 Longitudinal Stiffeners

Longitudinal stiffeners shall not be used without permission from the Director. This is due to the complexities with their fabrication. Though commonly used by TDOT in the past, the current AASHTO Specifications requiring longitudinal stiffeners to pass, uninterrupted, through stiffeners and requiring stiffeners to be welded to the longitudinal stiffeners has diminished their economic benefit. They may still be justifiable in extremely deep girders, but generally they are not warranted.

Section 19 Shear Connectors

Shear connectors (studs) shall be placed in both the positive and negative moment regions for all girders, except for bridge widenings where the existing girders do not have shear connectors in the negative moment regions.

Shear connectors shall not be placed on top of flange splice plates.

Section 20 Lateral Bracing

For straight steel bridges, the primary function of lateral bracing is to stabilize the steel girders during erection against transient dead and wind loads. The need for lateral bracing shall be investigated for spans of 200 feet or greater. Consider bracing requirements imposed upon the bridge by the erection process. Lateral bracing is normally required for spans of 200 feet or greater. For straight bridges, lateral bracing shall be required when:

$$\frac{L}{b} > 60$$

Where: L = length within a span where no lateral bracing is present (in.)

b = top flange width (in.) at the maximum stress point in the unbraced length, L

When required, bolt lateral bracing to the top flange between the fascia girder and the adjacent interior girder on both sides of the bridge as shown in Figure 1.

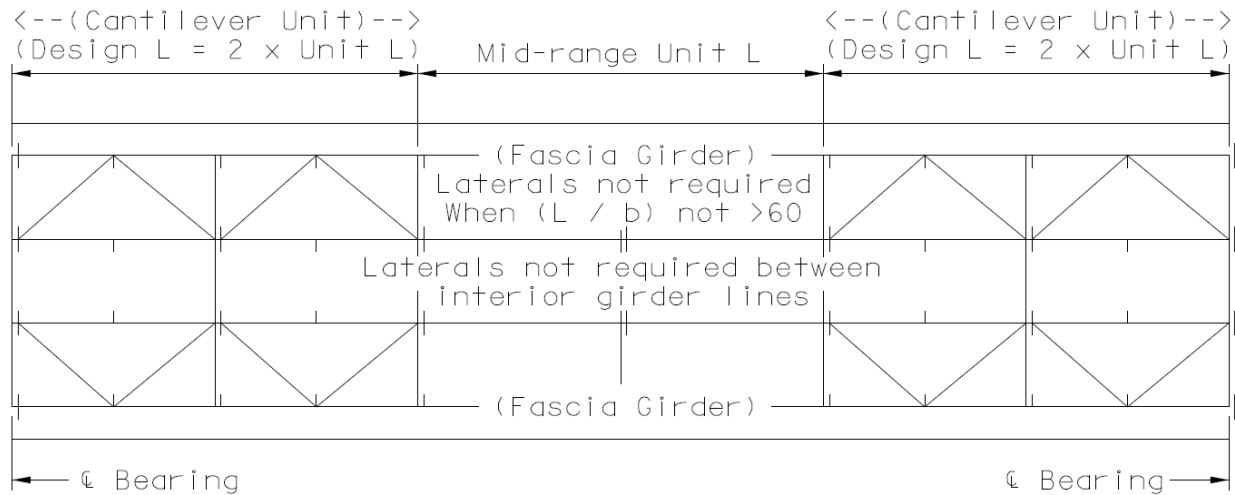

Figure 1. Partial Framing Plan

Lateral bracing in the plane of the top flange will laterally fix the cross-frame. The cross-frame will fix the bottom flange of the girder. Lateral bracing in both exterior bays is necessary so that the contractor can start the girder erection from either side of the bridge. Lateral bracing is not required in the mid-range of the span if adequate bracing is provided in the side ranges so that the L/b ratio of the mid-range of the span is less than 60. For girder sections that are cantilevered during erection, $L = 2$ times the actual cantilever length.

For curved bridges, lateral bracing shall always be placed in the last cross-frame bay at each abutment and expansion joint. The lateral bracing shall be placed in the top and bottom flanges between all girders. The primary function of the lateral bracing in these locations is to stabilize the steel framework during erection until the deck concrete is entirely placed and cured. For curved bridges, additional lateral bracing may be required for longer spans. If so, a finite element analysis will be required to properly model and design the girders.

Section 21 Stress Limit for Tension Flanges

AASHTO 6.10.1.8 shall be satisfied for all steel girders at all locations. No stresses exceeding the limits given in AASHTO 6.10.1.8 shall be allowed.

When designing steel girders, bolt holes are in tension flanges for various connections including tab connection plates, field splices, and occasionally lateral bracing. TDOT Structures Section Design Policy is to use bolted tab plates for connections to girder flanges to benefit from an improved fatigue detail category.

When applicable, straight composite steel girder sections may be designed using AASHTO 6.10.7.1 in positive moment regions, which is for compact sections. Compact section design permits tensile stresses exceeding the yield stress of the flange under certain cases. However, because of the holes in the tension flanges, AASHTO 6.10.1.8 must also be satisfied for positive and negative moment regions of all girders. This provision limits the stress in tension flanges to the lesser of the yield stress or a calculated stress value based on the specifics of the design.

The benefit of higher allowable stresses for compact section design in Article 6.10.7.1 is negated by Article 6.10.1.8 which limits the maximum allowable stress. Commercial design programs use AASHTO 6.10.7.1 for composite sections in positive moment areas for straight steel bridges. However, these programs may not check AASHTO 6.10.1.8. It is possible to satisfy 6.10.7.1 and not be flagged by the program but still be in violation of AASHTO 6.10.1.8.

All designers must check AASHTO 6.10.1.8 on their own using either hand calculations or a spreadsheet.

Section 22 Dead Load Correction Curve

A dead load correction curve for each span shall be included on the bridge plans. Each curve shall indicate dead load correction values for both steel self-weight and total dead load.

Section 23 Paint

All steel members designated to be painted shall be painted using System A in accordance with Sections 603 and 910 of the Standard Specifications.

Section 24 Faying Surfaces

All faying surfaces shall meet Class B surface conditions (slip coefficient = 0.50). See AASHTO 6.13.2.8.

Note that cross-frames for curved girders are considered primary members, and their faying surfaces are subject to the slip coefficient criteria.

Section 25 Web-to-Flange Welding

Design web-to-flange fillet welds and show them on the bridge plans with the girder detail drawings if they exceed the American Welding Society (AWS) minimums for the plate sizes to be welded. In most cases, the AWS minimum weld sizes (see AASHTO/AWS D1.5) will suffice. Welds

larger than 5/16-inch require multiple passes and increase fabrication costs. Check the shop drawings to verify that the Fabricator is using the proper weld size.

Section 26 Deflection Check for Slab Pouring Sequence

When designing the slab pouring sequence, the following additional check shall be made. The final deflection due to the noncomposite dead load after the last pour shall be compared to the deflection due to the noncomposite dead load assuming the entire slab was poured in a single pour. This check shall be made at 20th points along the bridge. The difference between the pouring sequence deflection and the single pour deflection shall not exceed ½-inch without approval from the Design Manager.

Bridges with three or fewer I-shaped steel girders shall meet the requirements of AASHTO 6.10.3.4.2.

Section 27 Cantilever Bracket Rotation

The effects of cantilever bracket rotation shall be checked for all steel girder bridges. A spreadsheet is available from the Structures Section to complete this check. When the slab cantilever brackets for the cantilever forms are installed, the brackets may be braced against the exterior girder web. If the girder web can deflect horizontally due to the horizontal force from the bracket during the slab pour, the edge of slab will deflect downward between web stiffeners. This can lead to permanent downward deflections in the edge of slab that allow water to “pond” at the base of the parapet.

Section 28 Cover Plates

Cover plates are not allowed. Their fatigue category is very low.

Section 29 Stain Prevention

For all weathering steel girders, drip plates (also called drip tabs) shall be provided to divert runoff water and protect abutments and columns from staining. Provide them on every girder because staining may occur before slab placement. Consider what the diverted water will stain. For example, do not place drip plates so close to substructure elements that wind blows diverted water onto the substructure.

Deck drains shall be placed so that water does not discharge onto the steel girders.

Appendix A: Additional Design Information

Appendix A identifies sound design practices that evolved from decades of bridge design within the Structures Section and highlights provisions of the AASHTO LRFD Bridge Design Specifications which might be overlooked by an inexperienced engineer.

1. Structural Steel Framing:

- When determining span lengths, note that if end spans are short in relation to interior spans, uplift can be a problem at the girder ends. If end spans are too long in relation to interior spans, a disproportionate amount of steel will be required for the end spans.
- Before starting the analysis, layout the superstructure steel framing plan. The framing plan includes the girders, cross-frames, lateral bracing, and field splice locations. It also identifies support locations. This will avoid an iterative design process of trying to get all the superstructure components to fit as the analysis progresses.
- For any given flange area, using a wider, thinner flange instead of a narrower, thicker flange will help enhance lateral stability, reduce weld volume at welded splices, minimize the impact of bolt holes in the flange, and facilitate using wider stiffeners.
- For long span bridges and curved bridges consider using double cross-frames at supports to transfer the lateral loads from the deck to the bearings. The cumulative magnitude of lateral loads resulting from curvature, wind, and seismic loads can be substantial. Vehicular and vessel collision are other less common but significant lateral loads.
- TDOT has historically installed lateral bracing that is bolted to the girder bottom flange. AASHTO advocates connecting lateral bracing to top flanges. Current FEA design models may indicate much higher loads in bottom flange lateral bracing than in top flange lateral bracing. The Designer must ascertain the best course of action when using lateral bracing. The Designer must be mindful of the impact of top flange lateral bracing upon the installation of SIP deck forms and the presence of additional bolt holes through tension flanges.
- An advantage can be gained from reducing the cross-frame spacing in the maximum positive and negative moment regions of curved girders to reduce warping stresses.
- Locate lateral bracing to not encroach upon bearing devices or flange tapers.

- When determining the thickness of plates such as splice plates and bearing stiffeners, consider using thicknesses that are already being used elsewhere on the bridge. Fabricators may have to buy a larger quantity of plate than required for a thickness with a small quantity, so allowing them to use plate thicknesses already on the bridge will usually not increase the cost and may even result in a cost savings.

2. Expansion Joint Impacts to the Steel Superstructure:

- When expansion joints are present at the end of a girder, apply a 20% contingency factor to the calculated thermal movement value and round up at least 1 inch. There is little benefit to minimizing the gap provided for thermal expansion at the end of the girder except to minimize the width of the abutment beam or bent cap. Size the gap with a liberal contingency recognizing that thermal expansion calculations are not exact and that the end of the cambered girder, prior to placement of the deck, is rotated toward the gap.
- Modular joint support boxes are restricted to maximum spacings based upon the Manufacturer's propriety design and design criteria. Be aware that skewed girders with wide flanges that converge at an expansion joint may not provide ample room for installation of the joint.

3. Bolted Field Splice Tactics That Promote Efficient Designs:

- Bolted field splices: Using a ½-inch minimum web splice plate thickness will ensure that plate thickness will not govern the minimum bolt spacing for bolts up to 1 inch in diameter.
- The capacity of tension flanges is negatively impacted by the presence of bolt holes. Increasing the width of a plate is more efficient than increasing the thickness in offsetting the bolt hole net section reduction. In a bolted flange splice, minimizing the number of bolt holes in the transverse rows will minimize the tension flange area reduction. For example, a 30-inch wide flange with 4 bolts per row would conserve more tension flange material than a 30-inch wide flange with 6 bolts per row.
- Interference fits of bolts, nuts, and splice plates at the juncture of the flange and web will occur unless proper attention is given to these details. Bolts and nuts may appear to have adequate clearance in the installed state but do not have adequate clearance to install the bolt, nut, or splice plate in an interim step.
- Ensure SIP metal deck form shop drawings make provisions for negotiating field splices.

- Two rows of bolts on each side of the vertical centerline of the web splice should suffice for most bridges. Adding more than two rows of bolts rapidly becomes inefficient.

4. Erection Plans:

- It is critical that the Engineer be provided with descriptions of cranes, crane charts, and crane rigging and their capacities. The locations of cranes, crane mats, haul roads, and barges shall be detailed on Erection Plan drawings for each step of the erection process.
- The Erection Plans shall describe (with details and notes) the installation of each component of the steel superstructure from the onset of erection to completion. All supplementary bracing and falsework shall be identified.
- Calculations are typically generated by a Consultant on behalf of the Contractor. These calculations shall demonstrate that the structure is stable at each step of the erection process. All assumed loads shall be consistent with the AASHTO Specifications governing erection.
- TDOT Structures reviews Erection Plans as a supportive service to the TDOT Construction Division. The Erection Plans are therefore to be directed to the TDOT Construction Office for their consideration. It is ultimately the responsibility of the TDOT Construction Office to approve or disapprove the Contractor's Erection Plan.

Appendix B. Standard Details

Appendix B contains the following standard details:

Figure 2. Standard Details for Cross-Frames and Lateral Bracing

Figure 3. Standard Details for Cross-Frames, Stiffeners, Tab Connection Plates, and Stringers

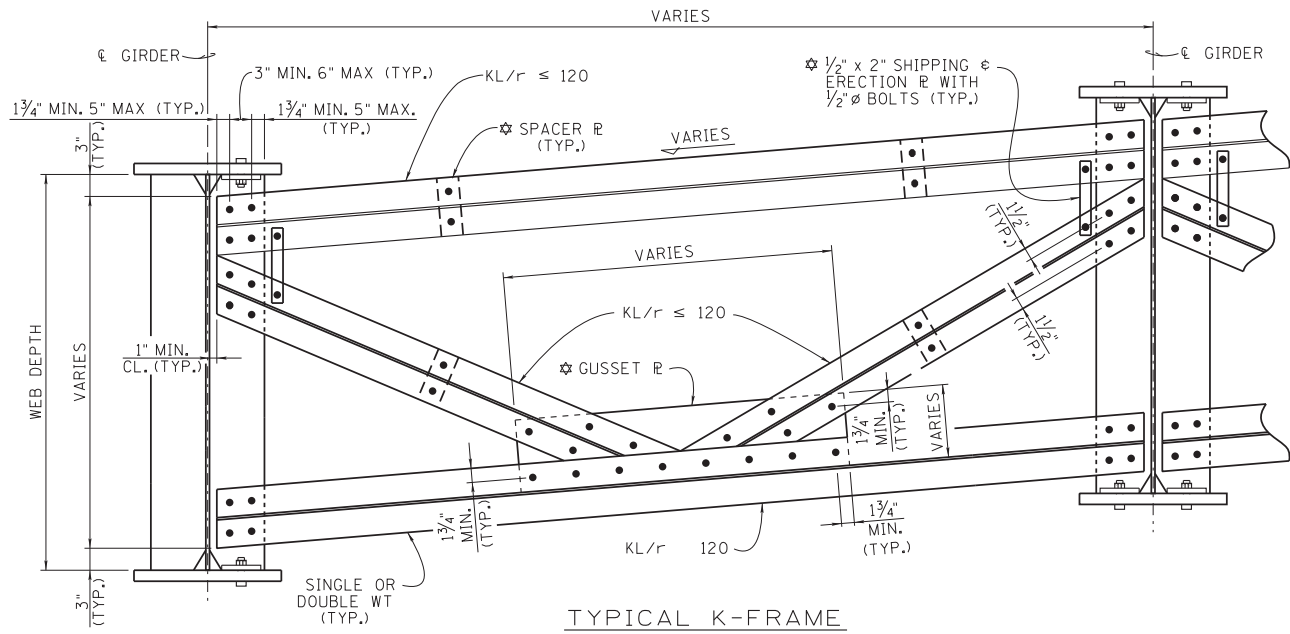

TYPICAL K-FRAME

(* PLATE THICKNESS SHALL MATCH STIFFENER THICKNESS WHEN USING DOUBLE MEMBERS AND NUMBER OF SPACER PLATES REQUIRED SHALL BE DETERMINED BY DESIGN.)

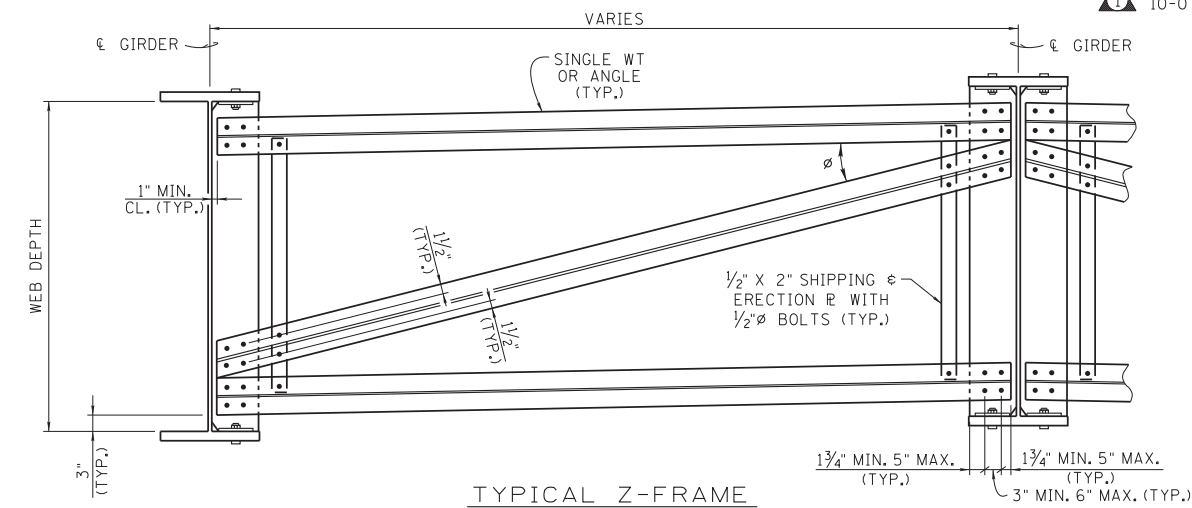

TYPICAL Z-FRAME

(NOT TO BE USED WITH CURVED GIRDERS, ROLLED GIRDERS, OR WHEN θ IS LESS THAN 30°)
(STRAIGHT GIRDER $KL/r \leq 140$ FOR SKEWS 70° TO 90°)
(STRAIGHT GIRDERS $KL/r \leq 120$ FOR SKEWS LESS THAN 70°)

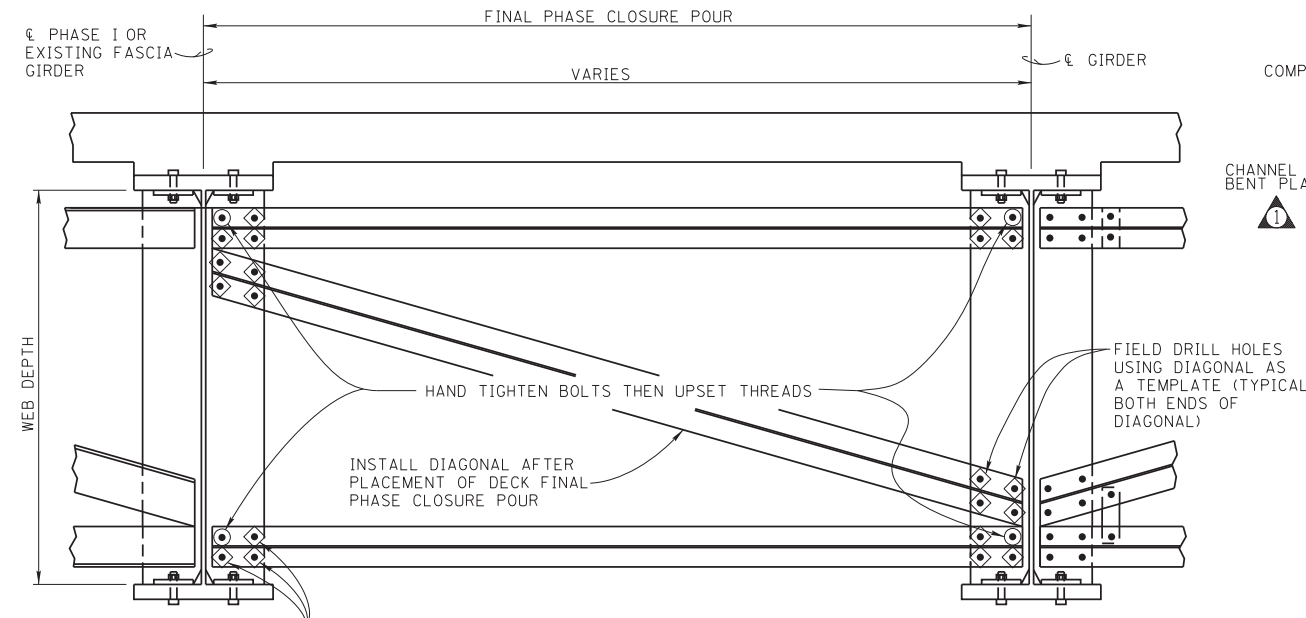

Z-FRAME DETAILS FOR CLOSURE POURS

(PHASE CONSTRUCTION OR WIDENING OF EXISTING BRIDGE)
(SEE PLANS NOTES FOR APPROPRIATE PLANS NOTE BASED ON BRACING TYPE.)
NOTE: HAND TIGHTENED BOLTS SHALL BE TENSIONED TO AASHTO SPECIFICATIONS AFTER PLACEMENT OF DECK FINAL CLOSURE POUR.
NOTE: OVERSIZED OR SLOTTED BOLT HOLES SHALL NOT BE PERMITTED UNLESS OTHERWISE NOTED.

GENERAL NOTES

- NOTE: ALL BOLTS SHALL BE EITHER ASTM F3125 GRADE A325 OR GRADE A490. TYPE SHALL BE DETERMINED BY DESIGN.
- NOTE: DIRECT TENSION INDICATOR (DTI) WASHERS SHALL NOT BE USED ON WEATHERING STEEL.
- NOTE: ALL BOLTS SHALL BE TENSIONED TO AASHTO LRFD SPECIFICATIONS UNLESS NOTED OTHERWISE.
- NOTE: CONNECTION BOLTS AND WELD SIZES SHOWN ON THIS DRAWING ARE FOR ILLUSTRATIVE PURPOSES ONLY. THE ACTUAL QUANTITY OF BOLTS AND WELD SIZE OF EACH CONNECTION SHALL BE DETERMINED BY DESIGN.

NOTES TO DESIGNER

- NOTE: USE CHANNEL BRACING FOR ROLLED GIRDERS.
- NOTE: USE Z-FRAME BRACING WHEN THE DIAGONAL ANGLE θ IS EQUAL TO OR GREATER THAN 30°.
- NOTE: USE K-FRAME BRACING FOR CURVED GIRDERS AND GIRDER-STRINGER SYSTEMS.
- NOTE: USE EITHER K-FRAME BRACING OR CHANNEL BRACING WHEN THE DIAGONAL ANGLE θ IS LESS THAN 30°.
- NOTE: K-FRAMES NOT SUPPORTING A STRINGER SHOULD PREFERABLY BE SINGLE MEMBERS TO PROMOTE EASE OF ERECTION. HOWEVER, USE DOUBLE MEMBERS WHEN REQUIRED BY DESIGN.

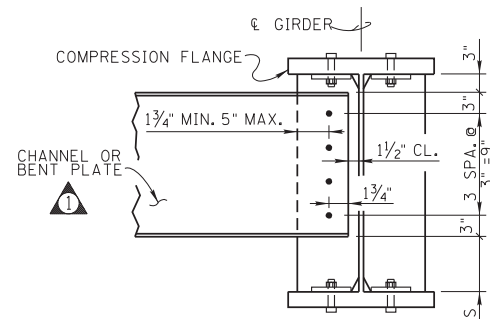

TYPICAL CHANNEL BRACING

NOTE: 1" \varnothing ASTM F3125 GRADE A325 BOLTS TO BE USED.

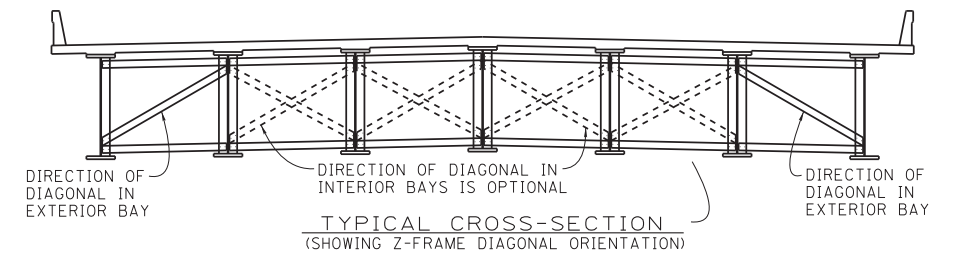

TYPICAL CROSS-SECTION (SHOWING Z-FRAME DIAGONAL ORIENTATION)

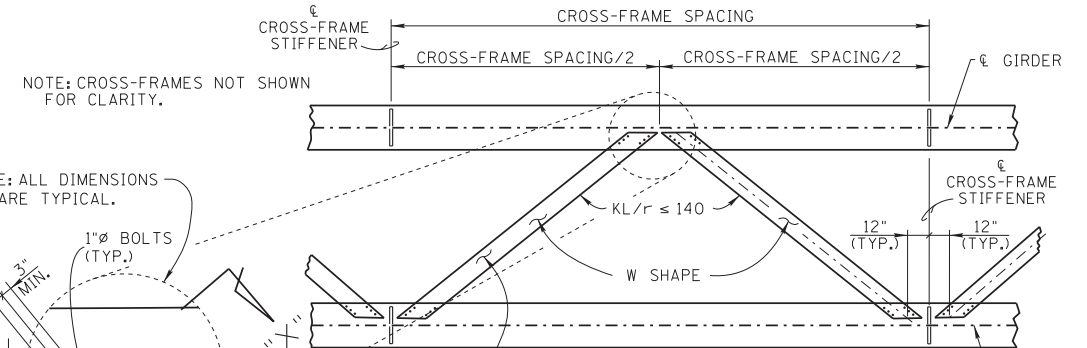

LATERAL BRACING DETAIL

WHEN REQUIRED FOR STRAIGHT GIRDERS, ATTACH LATERAL BRACING TO THE TOP FLANGE. FOR ALL CURVED GIRDERS, USE LATERAL BRACING AT ABUTMENTS AND EXPANSION JOINTS IN BOTH THE TOP AND BOTTOM FLANGES OF THE LAST CROSS-FRAME BAY. FOR ALL CURVED GIRDERS, ADDITIONAL LATERAL BRACING MAY BE REQUIRED FOR LONGER SPANS. IF SO, A FINITE ELEMENT ANALYSIS WILL BE REQUIRED TO PROPERLY MODEL AND DESIGN THE GIRDERS.

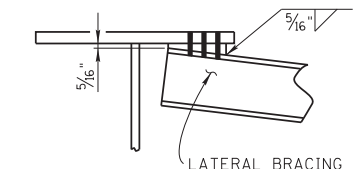

SECTION "X"- "X"

(NOTE: BEVELED SPACER PLATE REQUIRED AT EACH LATERAL END CONNECTION.)
(BEVEL ALONG AXIS OF BRACING)
(TRANSVERSE BEVEL NOT REQUIRED)

STATE OF TENNESSEE
DEPARTMENT OF TRANSPORTATION
STANDARD DETAILS
FOR
CROSS-FRAMES AND
LATERAL BRACING
2022

CORRECT *Jed A. Krivonoz*
ENGINEER OF STRUCTURES

Version History and Revision Summary

Version history and a summary of revisions are given in Table 2. Minor editorial revisions may not be included in the summary.

Version	Revision Summary
02012022	Initial Release
10072024	Added Version History and Revision Summary; Added new Sections 9 and 12 and renumbered other Sections. Revised Sections 2 and 15, Revised Figures 2 and 3

Table 2. Version History and Revision Summary