

NOTE: AFTER ALL FABRICATION IS COMPLETE, THE GRATE ASSEMBLY SHALL BE ZINC COATED AS SPECIFIED BY ASTM A-123 SPECIFICATIONS FOR HOT-DIP GALVANIZED COATINGS. COATING THICKNESS SHALL BE AS SPECIFIED IN TABLE FOR MATERIAL 1/4" AND OVER. (2.3 oz/FT²).

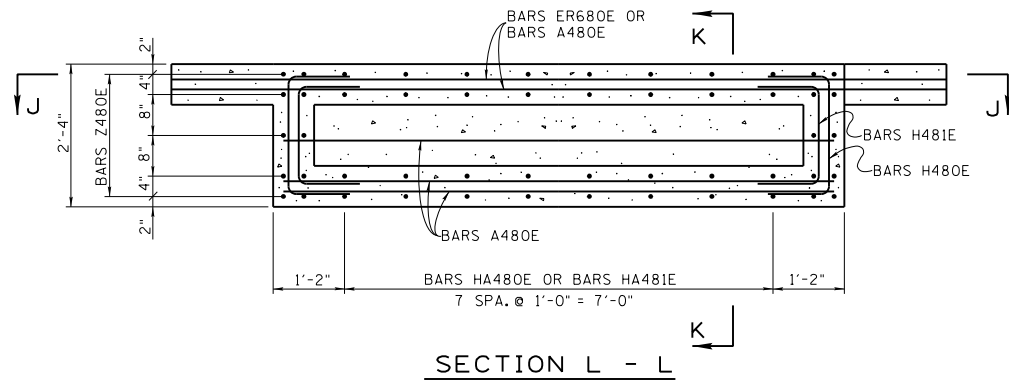

SECTION L - L

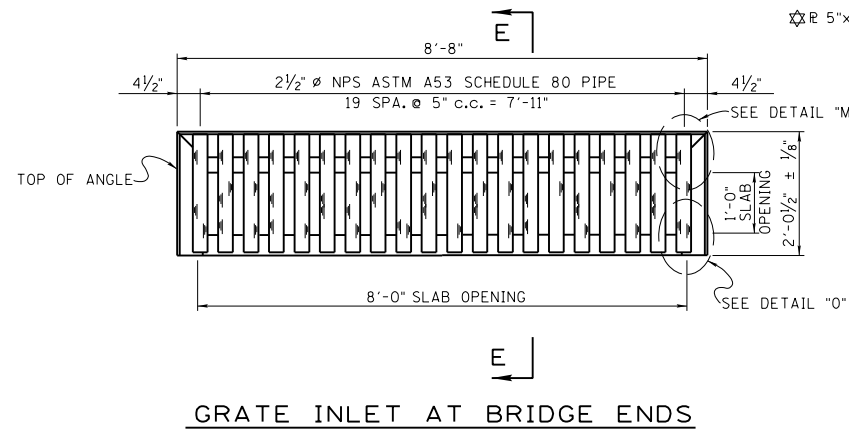

GRATE INLET AT BRIDGE ENDS

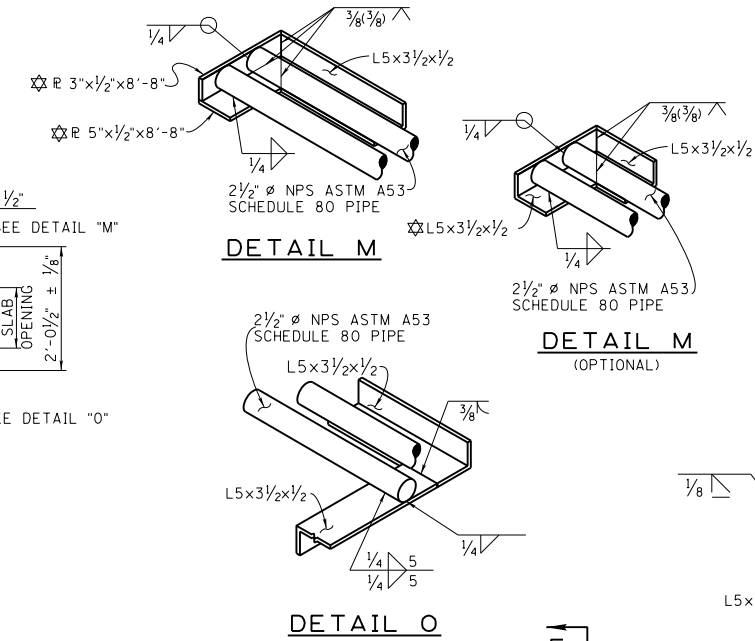

DETAIL M

DETAIL N (OPTIONAL)

DETAIL O

DETAIL P

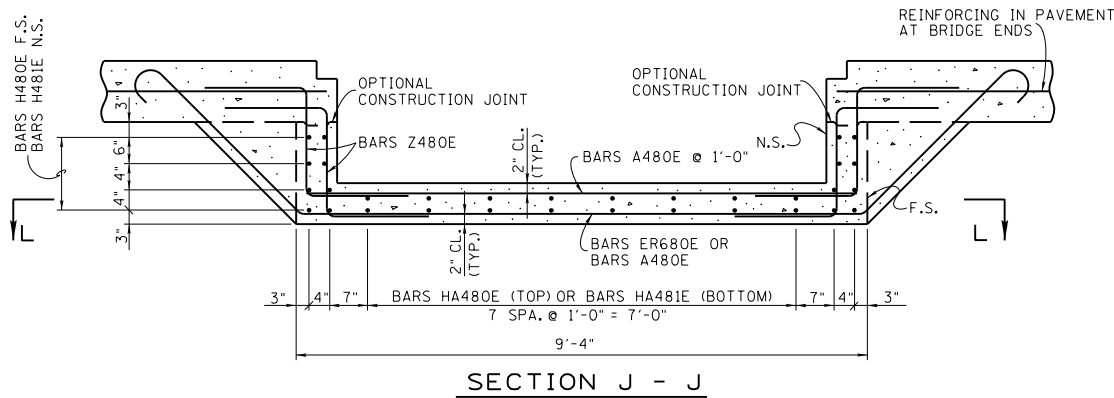

SECTION J - J

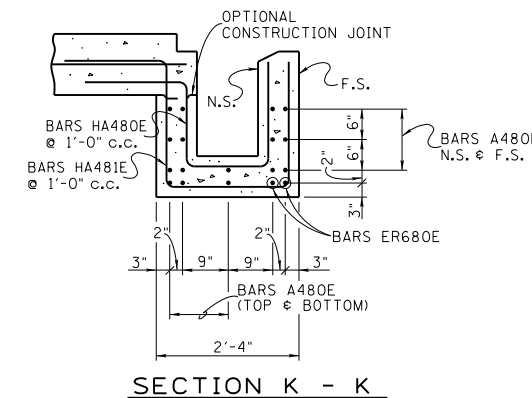

SECTION K - K

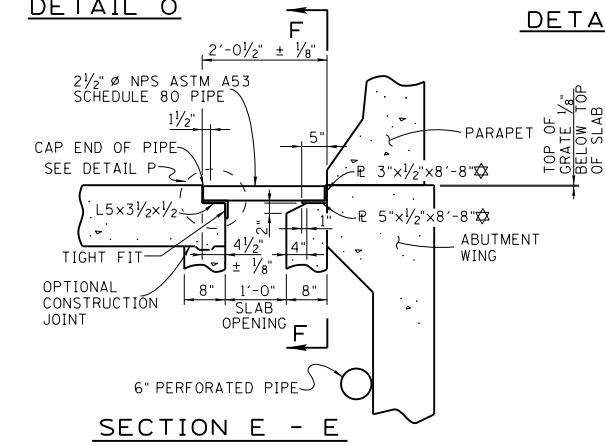

SECTION E - E

☆ DENOTES: THE CONTRACTOR HAS THE OPTION TO USE L5x3 1/2x1/2 IN LIEU OF R 3"x1/2"x8'-8" & R 5"x1/2"x8'-8". SEE DETAIL 'M' (OPTIONAL).

N.S. DENOTES NEAR SIDE
F.S. DENOTES FAR SIDE

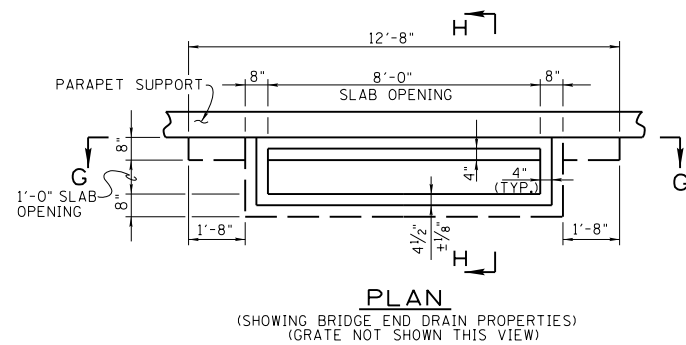

PLAN
(SHOWING BRIDGE END DRAIN PROPERTIES)
(GRATE NOT SHOWN THIS VIEW)

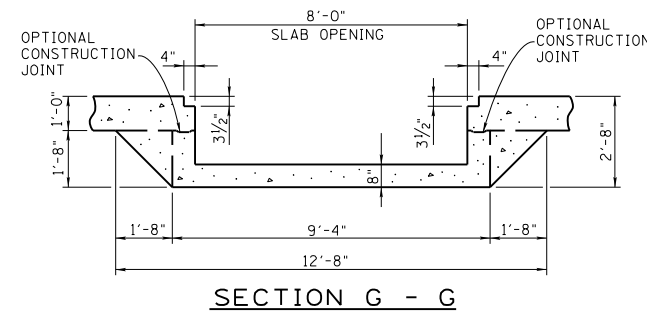

SECTION G - G

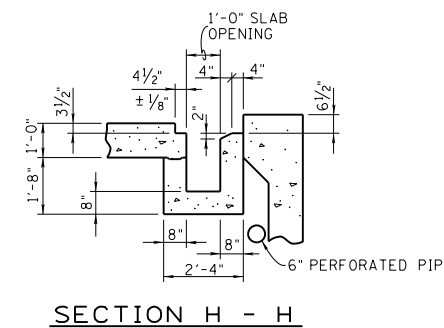

SECTION H - H

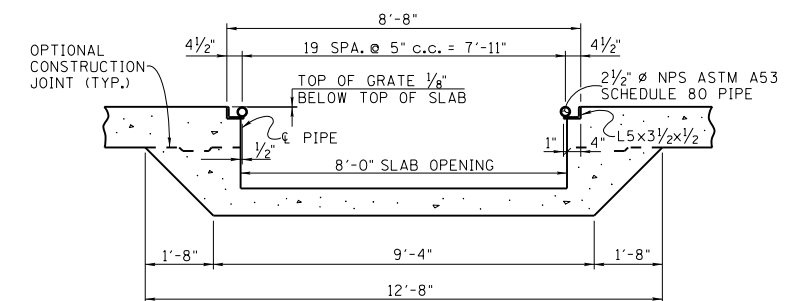

SECTION F - F

PROJECT NO.	YEAR	SHEET NO.
	2021	

REVISIONS			
NO.	DATE	BY	BRIEF DESCRIPTION
1	5/10/21	TAK	RE-ISSUED DRAWING

NOTE: FOR ADDITIONAL DETAILS SEE STD-1-1 THRU 7.

STATE OF TENNESSEE
DEPARTMENT OF TRANSPORTATION
BRIDGE END DRAIN DETAILS
2' x 8'-7" WITH
PAVEMENT AT BRIDGE ENDS
2021

CORRECT *Ded A Krniewyaz*
ENGINEER OF STRUCTURES

DESIGNED BY C.M. HILES
DRAWN BY SIM FRANKENFIELD
SUPERVISED BY C.M. HILES
CHECKED BY _____

DATE _____
DATE _____
DATE _____
DATE _____