

CONST. NO.:

PROJECT NO.	YEAR	SHEET NO.	
- -	2020		
REVISIONS			
NO.	DATE	BY	BRIEF DESCRIPTION
1	03-01-22	TAK	GENERAL REVISIONS
2	01-10-24	ALP	GENERAL REVISIONS
- -			
- -			
- -			

NOTES

LOCATION OF FLUMES WILL BE DETERMINED BY THE HYDRAULIC DESIGN SECTION AND SHOWN ON THE BRIDGE PLANS BASED ON THE ROADWAY GEOMETRY.

PROPOSED FLUME ON EXISTING ROADWAY SLOPES SHALL BE EXCAVATED TO MATCH THE WIDTH AND DEPTH DIMENSIONS SHOWN ON THIS DRAWING.

GEOTEXTILE REINFORCEMENT BETWEEN THE EXCAVATED EMBANKMENT AND RIP-RAP STONE SHALL BE TYPE IV WOVEN FABRIC AND MEET THE MATERIAL REQUIREMENTS OF TDOT QPL 36.

RIP-RAP FOR THE FLUME SHALL BE CLASS "A-1" AND PLACED TO CONFORM WITH THE DIMENSIONS AND GENERAL SHAPE AS SHOWN ON THIS DRAWING.

RIP-RAP IN THE TOP FIVE (5) FEET ADJACENT TO THE ROADWAY SHALL BE GROUTED. COST OF GROUT TO BE INCLUDED IN THE UNIT PRICE BID FOR OTHER ITEMS.

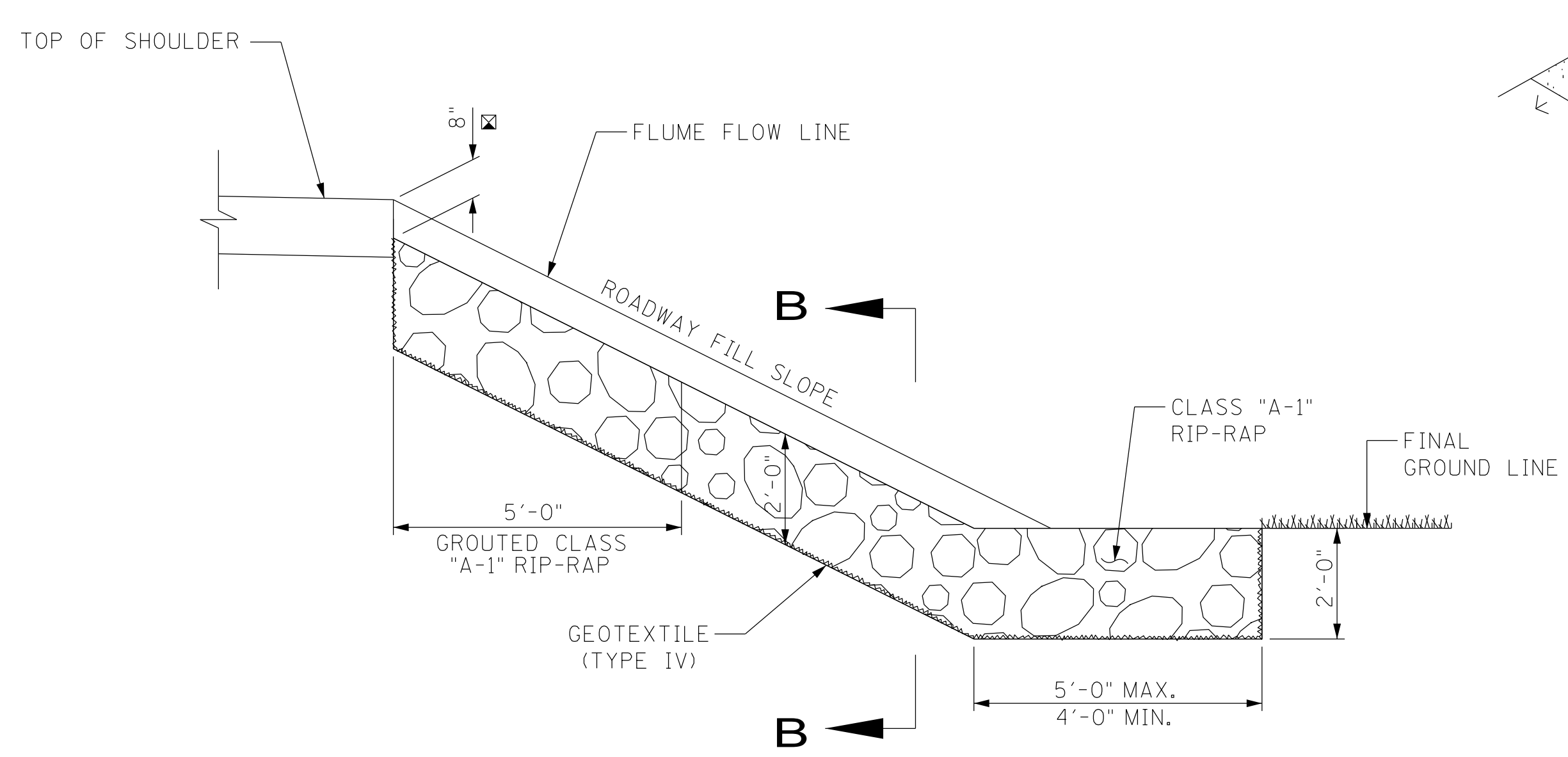
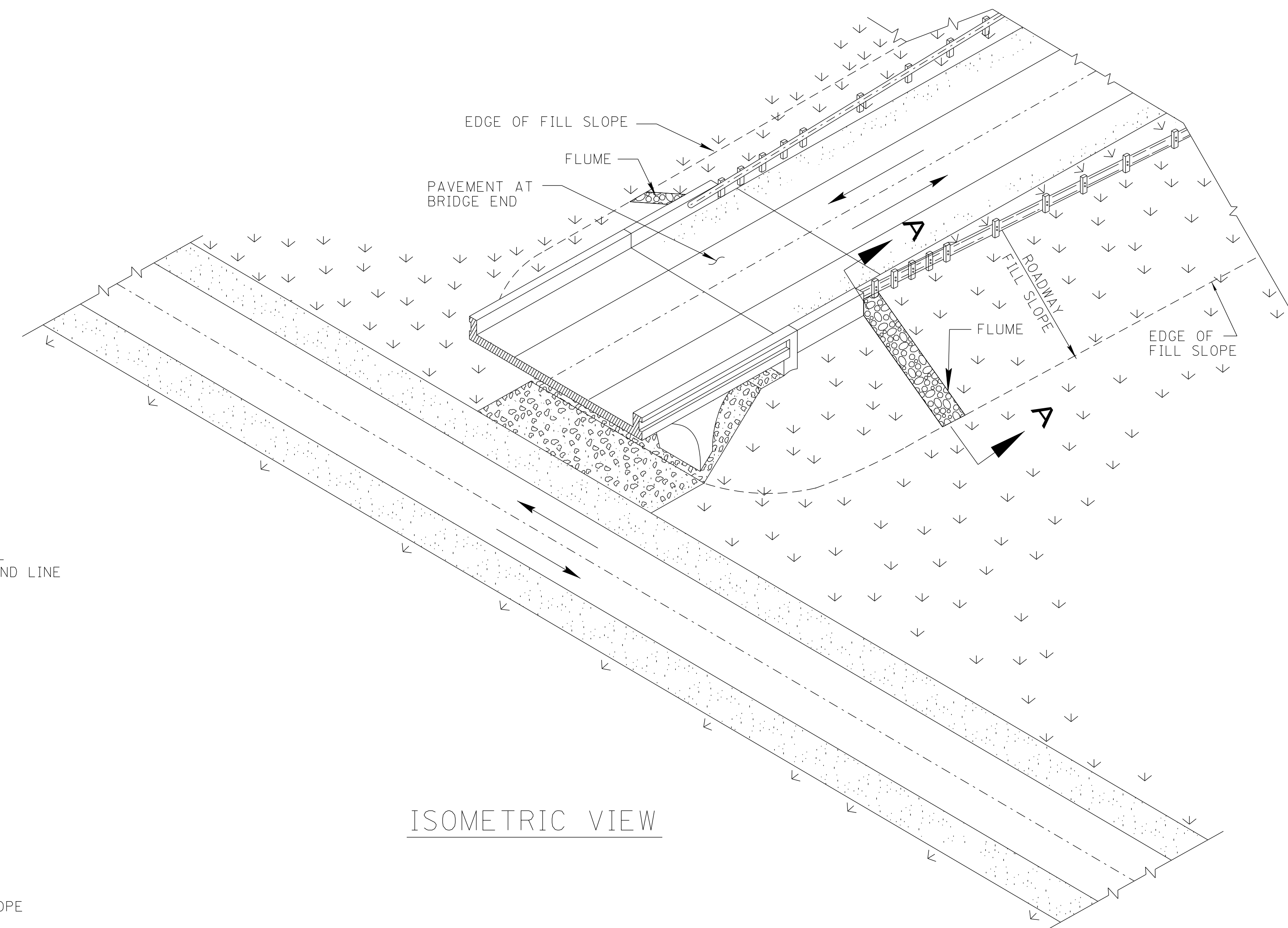

☒ DENOTES: PLACEMENT OF GROUT SHALL NOT REDUCE THE 8" FLUME DEPTH.

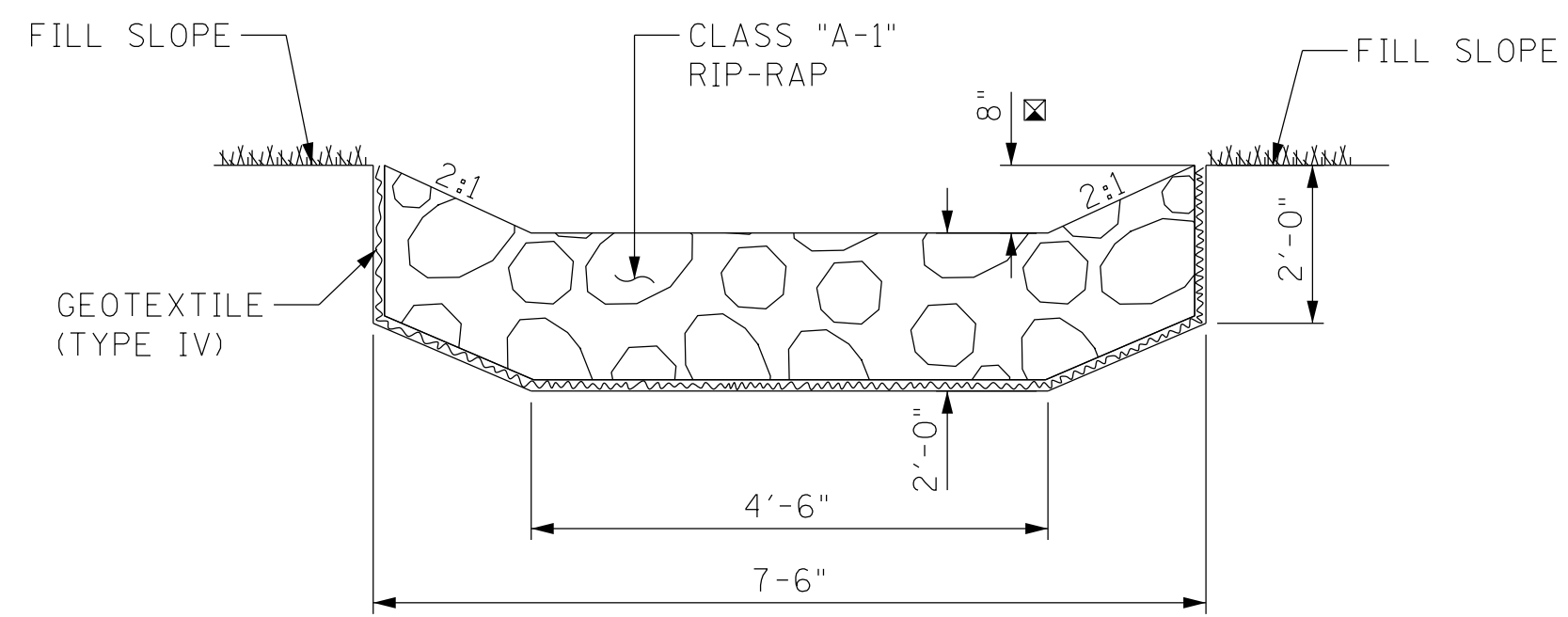

STATE OF TENNESSEE
DEPARTMENT OF TRANSPORTATION

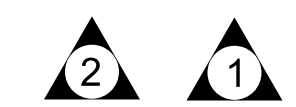

STANDARD FLUME
DETAILS
2020

DESIGN BY: TDOT STRUCTURES DATE: 08/01/2020
 DRAWN BY: GARY YOUNG DATE: 08/01/2020
 SUPERVISED BY: TED KNIAZEWCZ DATE: 08/01/2020
 CHECKED BY: TED KNIAZEWCZ DATE: 08/01/2020