

TANGENT SECTION

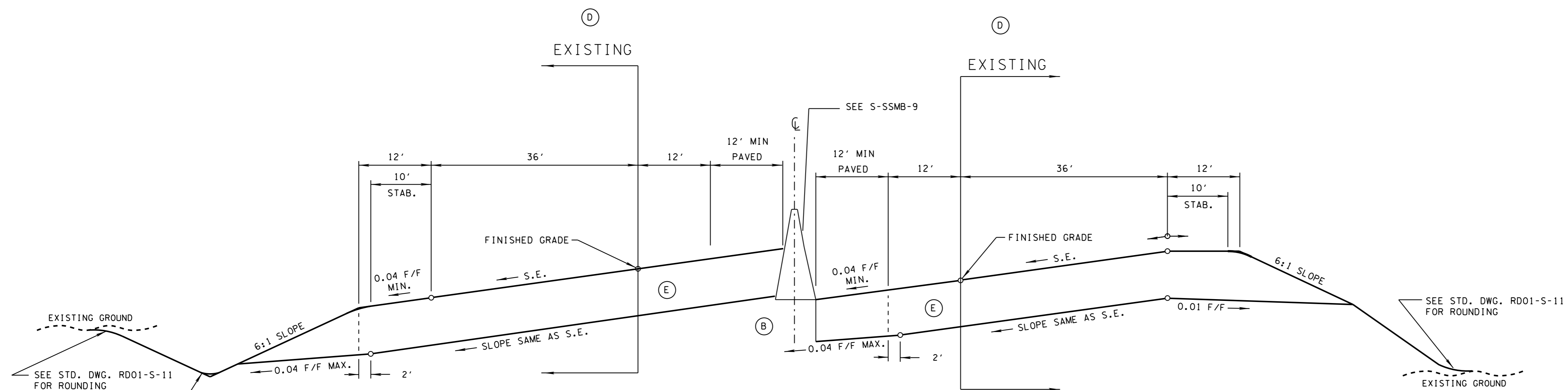

SUPERELEVATED SECTION

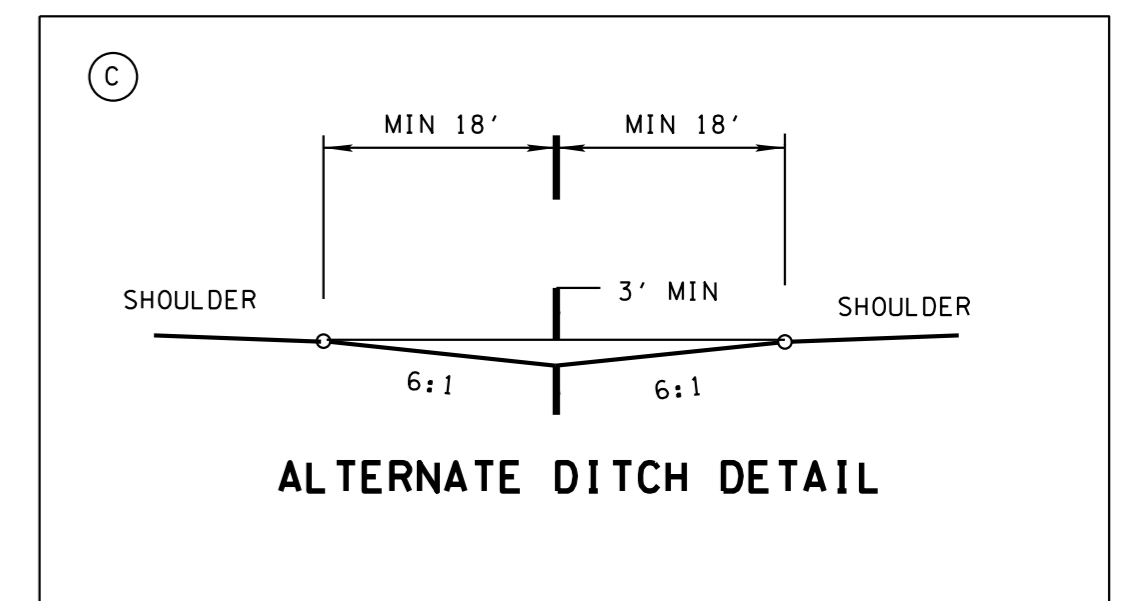

**PURPOSE**

THIS STANDARD IS ONLY TO BE USED FOR THE WIDENING OF EXISTING SIX LANE FREEWAYS WHERE THE NEW LANES TO BE ADDED UTILIZE THE EXISTING MEDIAN.

**DESIGN STANDARD**

SEE TABLE II ON RD01-TS-5

**GENERAL NOTES**

(A) SEE GUARDRAIL DRAWINGS FOR TYPICAL PLACEMENT.

(B) SEE S-SSMB-2 OR S-SSMB-9 FOR BARRIER WALL DETAILS.

(C) IF THE EXISTING MEDIAN IS WIDE ENOUGH, A MEDIAN DITCH MAY BE BUILT PROVIDED THAT THE DITCH IS AT LEAST 3 FEET DEEP AND THE FORESLOPES ARE NO STEEPER THAN 6:1. SHORT SECTIONS OF DITCH BETWEEN SECTIONS OF MEDIAN WALL ARE UNDESIRABLE.

(D) EXISTING LANES TO REMAIN IN PLACE UNLESS OTHERWISE SPECIFIED.

(E) EXISTING INSIDE SHOULDERS REQUIRE FULL DEPTH REMOVAL UNLESS OTHERWISE SPECIFIED.