

12/11/2020 1:23:48 PM P:\StandDraw\DESIGN STANDARDS\Standards Drawings\Standard Roadway Drawings - CURRENT\In Progress\10-108.00 Erosion Prevention and Sediment Control\IP180.03 Ditch Devices\PIECSTR6-20

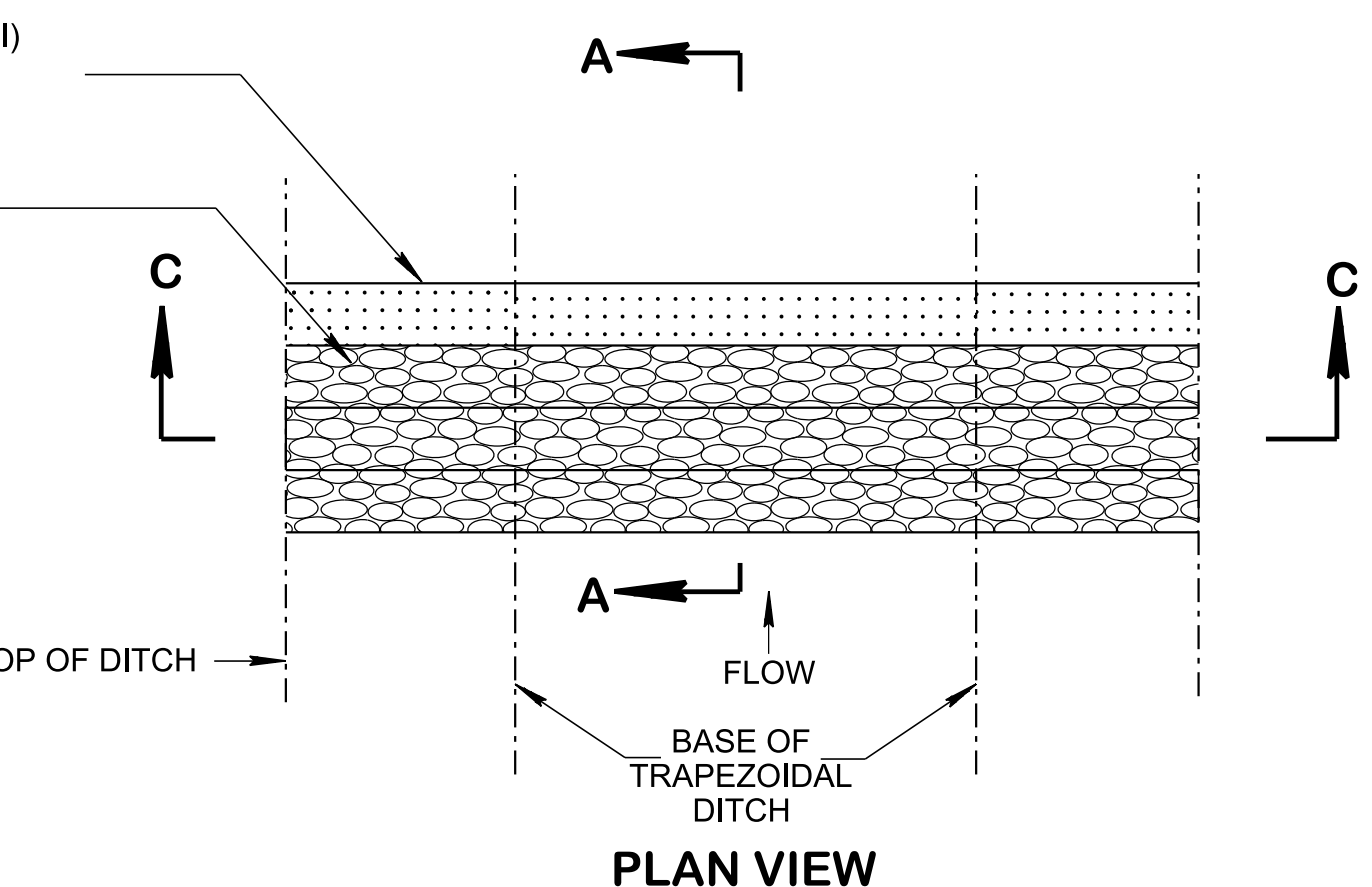

DETAIL FOR V-DITCH

DETAIL FOR TRAPEZOIDAL DITCH

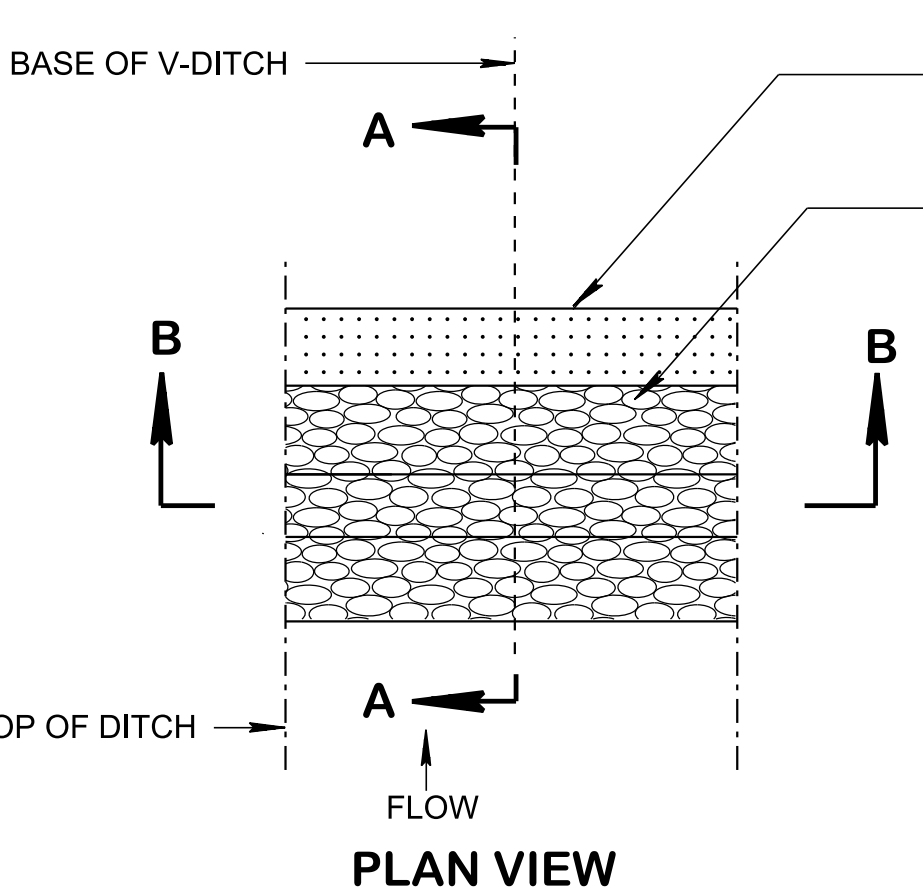
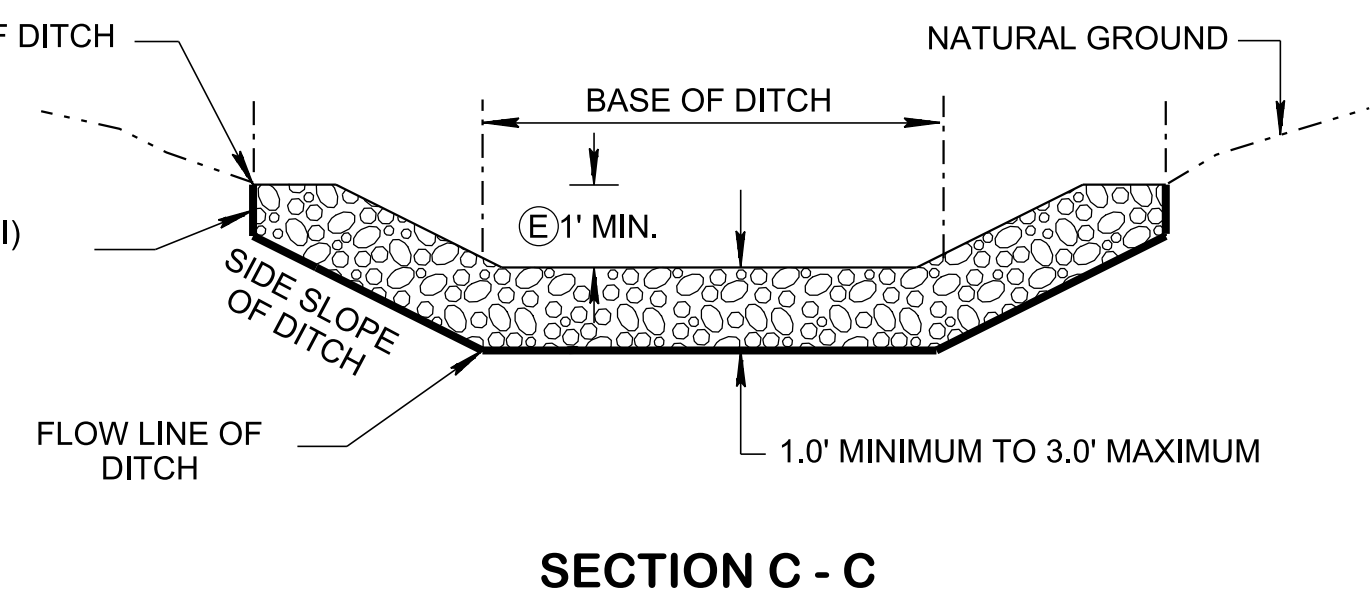
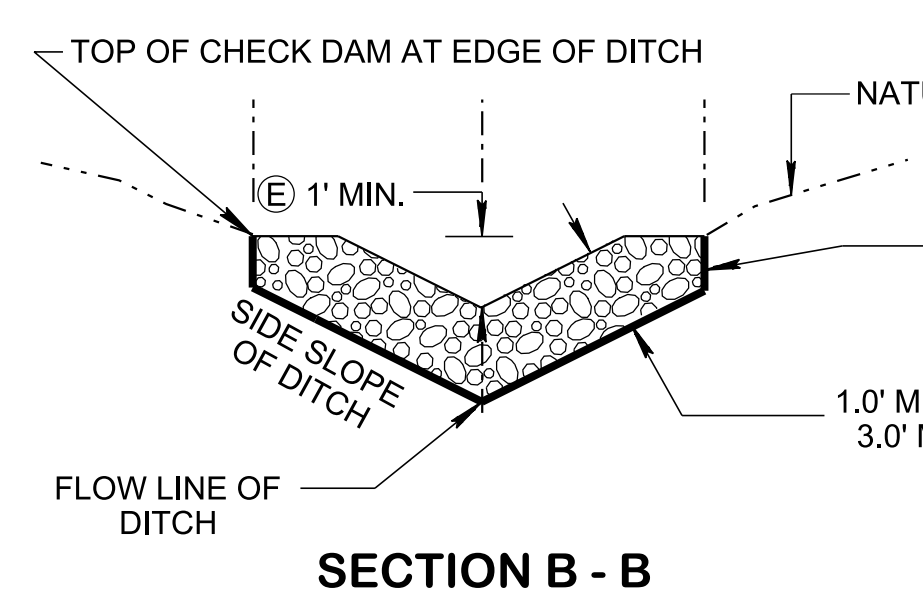
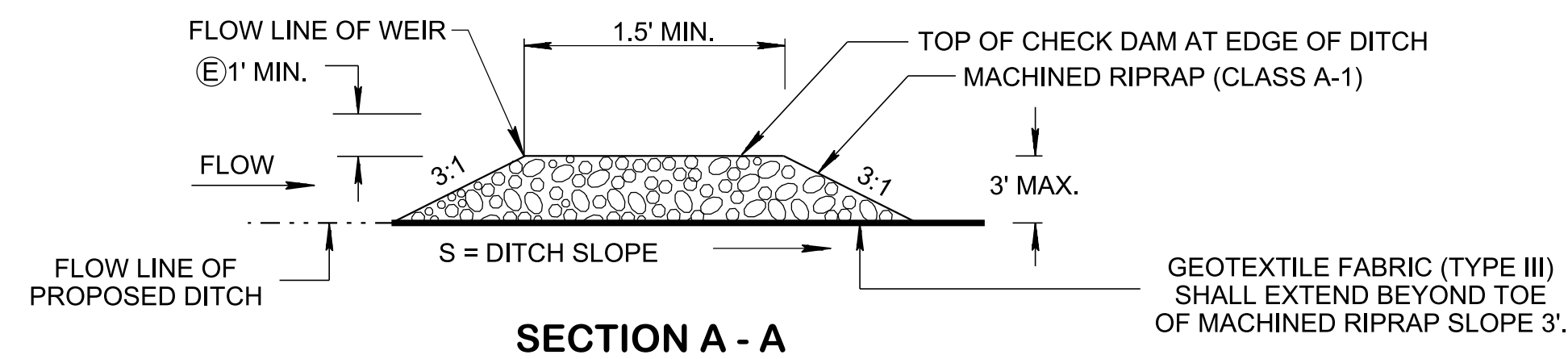
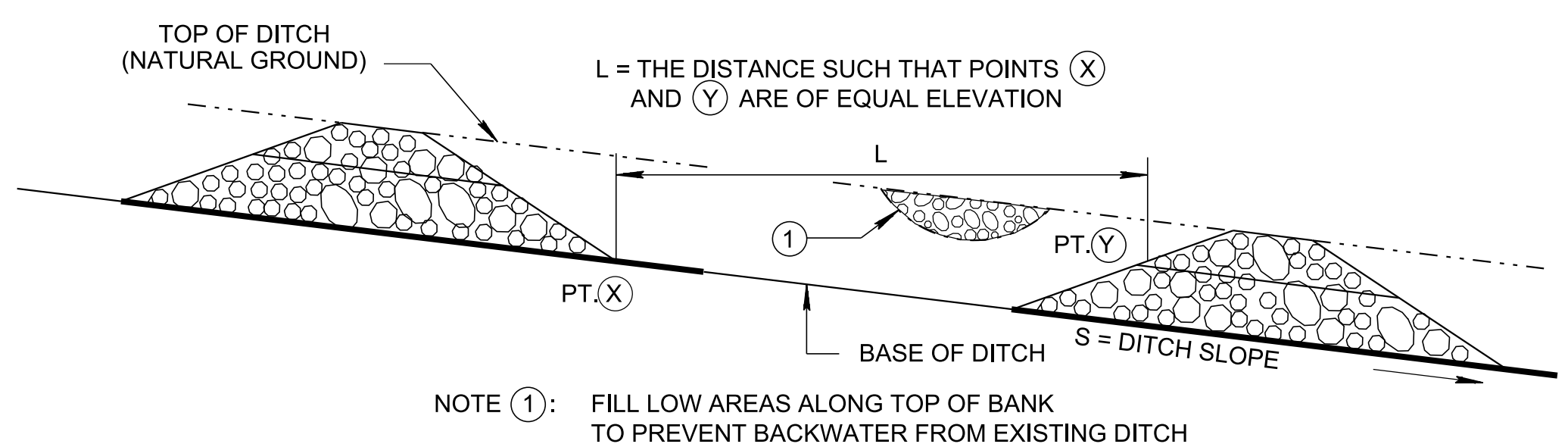

DETAIL FOR SPACING BETWEEN CHECK DAMS

**ROCK CHECK DAM ESTIMATED QUANTITIES**

|                     | 2:1 DITCH SLOPE |             |               | 3:1 DITCH SLOPE |             |               | 4:1 DITCH SLOPE |             |               |
|---------------------|-----------------|-------------|---------------|-----------------|-------------|---------------|-----------------|-------------|---------------|
|                     | HEIGHT FT       | RIP RAP TON | GEOTEXTILE SF | HEIGHT FT       | RIP RAP TON | GEOTEXTILE SF | HEIGHT FT       | RIP RAP TON | GEOTEXTILE SF |
| V-DITCH ②           | 1.5             | 6.5         | 16.8          | 1.5             | 9.2         | 23.7          | 1.5             | 12.0        | 30.9          |
|                     | 2.0             | 13.0        | 24.6          | 2.0             | 18.4        | 34.8          | 2.0             | 24.1        | 45.4          |
|                     | 2.5             | 22.8        | 33.9          | 2.5             | 32.3        | 48.0          | 2.5             | 42.1        | 62.5          |
|                     | 3.0             | 36.5        | 44.7          | 3.0             | 51.7        | 63.2          | 3.0             | 67.3        | 82.5          |
| TRAPEZOIDAL DITCH ③ | 1.5             | 8.9         | 22.8          | 1.5             | 11.6        | 29.7          | 1.5             | 14.4        | 36.9          |
|                     | 2.0             | 16.9        | 31.9          | 2.0             | 22.3        | 42.1          | 2.0             | 27.9        | 52.7          |
|                     | 2.5             | 28.7        | 42.6          | 2.5             | 38.1        | 56.6          | 2.5             | 47.9        | 71.2          |
|                     | 3.0             | 44.7        | 54.7          | 3.0             | 59.8        | 73.2          | 3.0             | 75.5        | 92.4          |

② ESTIMATED QUANTITIES BASED ON 4:1 SIDE SLOPES. QUANTITIES WILL VARY BASED ON ACTUAL DITCH CONFIGURATION.  
 ③ ESTIMATED QUANTITIES BASED ON 4 FT BOTTOM WIDTH, AND 4:1 SIDE SLOPES. QUANTITIES WILL VARY BASED ON ACTUAL DITCH CONFIGURATION.

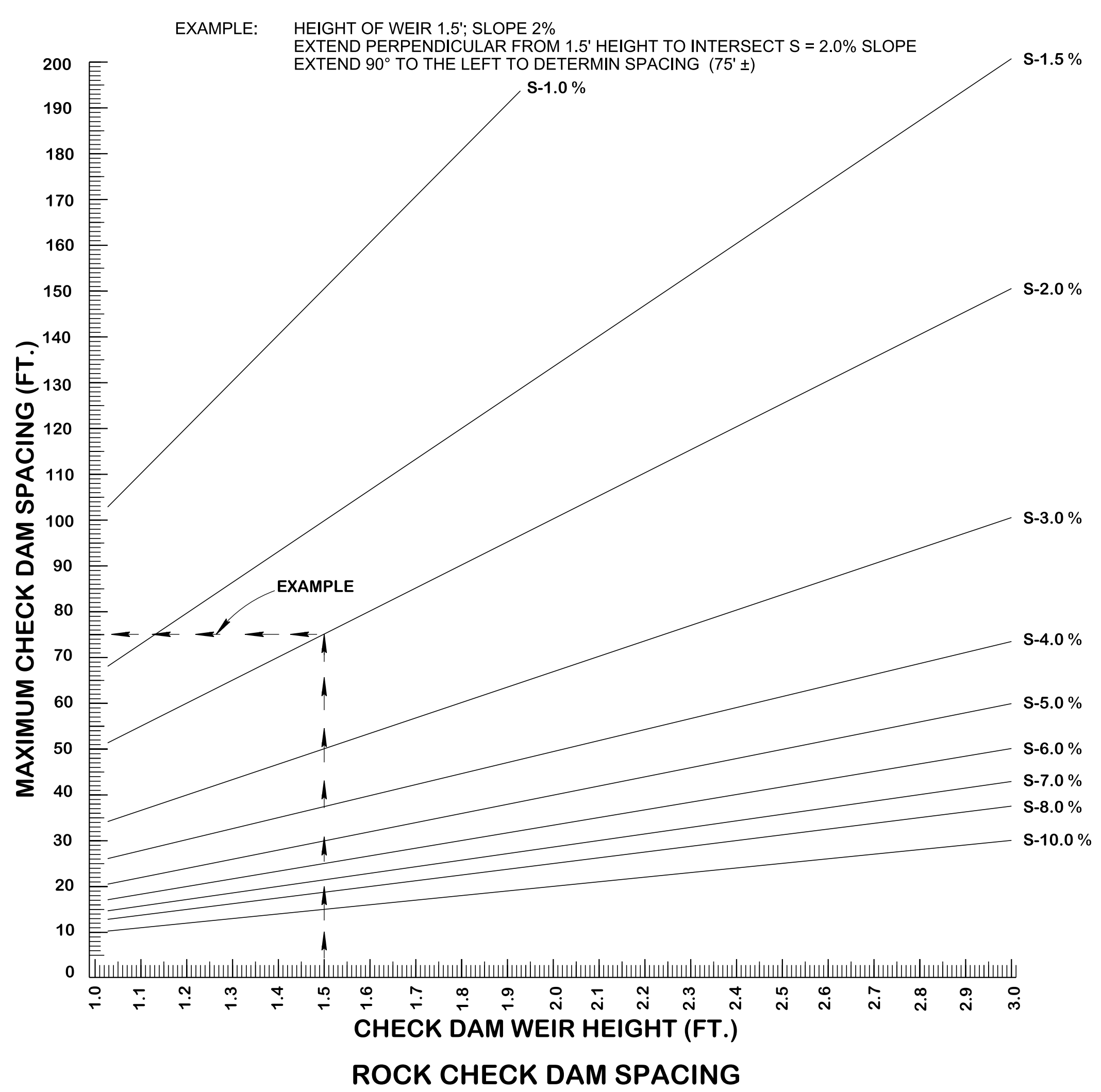

**ROCK CHECK DAM GENERAL NOTES**

- (A) ROCK CHECK DAMS ARE TO BE USED FOR VELOCITY REDUCTION AND EROSION PREVENTION IN AREAS WHERE CONCENTRATED FLOW EXISTS. ROCK CHECK DAMS SHALL NOT BE USED IN STREAMS OR OTHER NATURAL WATER RESOURCES. ROCK CHECK DAMS ARE NOT TO BE USED FOR SEDIMENT CONTROL AND SHOULD NOT BE CONSIDERED A SEDIMENT TRAPPING DEVICE.
- (B) THE DRAINAGE AREA FOR THE ROCK CHECK DAMS SHALL BE 10 ACRES OR LESS.
- (C) ROCK CHECK DAMS MAY REMAIN IN PLACE AS PERMANENT CHECK DAMS, IF SHOWN IN THE PLANS OR AS DIRECTED BY THE ENGINEER.
- (D) THE CENTER OF THE ROCK CHECK DAM MUST BE AT LEAST ONE (1) FOOT LOWER THAN THE OUTER EDGES.
- (E) THE DEPTH OF FLOW ON THE CENTER OF THE STRUCTURE SHALL BE COMPUTED FOR THE PEAK FLOW RATE GENERATED BY THE 2-YEAR, 24-HOUR STORM IN ORDER TO ENSURE THAT THE TOP OF THE STRUCTURE WILL NOT BE OVERTOPPED. FOR SITES WHICH DRAIN TO EXCEPTIONAL TENNESSEE WATERS OR SEDIMENT-IMPAIRED STREAMS, THE DEPTH SHOULD BE DETERMINED FOR THE 5-YEAR, 24-HOUR PEAK FLOW RATE. THIS WILL ELIMINATE THE ROCK-SOIL FAILURE POINT WHERE THE ROCK CHECK DAM AND NATURAL GROUND MERGE.
- (F) FOR SITES WHICH DRAIN TO EXCEPTIONAL TENNESSEE WATERS OR SEDIMENT-IMPAIRED STREAMS, THE MINIMUM HEIGHT OF THE STRUCTURE ABOVE THE DITCH BOTTOM SHALL BE INCREASED TO 2 FEET.
- (G) THE MAXIMUM SPACING BETWEEN ROCK CHECK DAMS SHOULD BE SUCH THAT THE TOE OF THE UPSTREAM DAM IS AT THE SAME ELEVATION AS THE FLOW LINE OF THE WEIR OF THE DOWNSTREAM DAM (SEE ROCK CHECK SPACING GRAPH THIS SHEET).
- (H) ONLY GEOTEXTILE FABRIC (TYPE III) LISTED ON THE QUALIFIED PRODUCTS LIST SHALL BE USED.
- (I) PRODUCTS LISTED ON THE QUALIFIED PRODUCTS LIST FOR FILTER SOCK DITCH APPLICATION (SEE STANDARD DRAWING EC-STR-8) MAY BE USED AND SHALL BE PAID UNDER FOLLOWING ITEM NUMBER:  
 209-08.09, FILTER SOCK CHECK DAM, EACH.
- (J) ROCK CHECK DAMS SHALL BE PAID FOR UNDER THE FOLLOWING ITEM NUMBER:  
 209-08.07, ROCK CHECK DAM, EACH.  
 PAYMENT SHALL INCLUDE ALL MATERIALS AND LABOR NECESSARY FOR CONSTRUCTION, MAINTENANCE, AND REMOVAL OF ROCK CHECK DAMS.
- (K) SEDIMENT SHALL BE REMOVED FROM BEHIND THE ROCK CHECK DAMS WHEN IT HAS ACCUMULATED TO ONE-HALF THE ORIGINAL HEIGHT OF THE DAM AND PAID FOR UNDER ITEM NUMBER:  
 209-05, SEDIMENT REMOVAL, C.Y.

REV. 12-18-95: CHANGED DRAWING NO. FROM ESC-STR-6 TO EC-STR-6.  
 REV. 7-29-96: MADE MINOR CORRECTIONS TO GENERAL NOTES.  
 REV. 4-15-98: CHANGED PAY ITEMS FOR CHECK DAMS.  
 REV. 5-27-01: CHANGED DESCRIPTION FOR GEOTEXTILE FABRIC (TYPE III, CLASS A) TO GEOTEXTILE FABRIC (TYPE III).  
 REV. 12-18-02: CHANGED GENERAL NOTE (G).  
 REV. 1-22-03: CORRECTED NOTE IN SECTION A-A.  
 REV. 4-15-06: REFORMATTED SHEET, REVISED NOTES, MISC. EDITS TO DRAWING.  
 REV. 4-1-08: REMOVED TEMPORARY REFERENCE, REVISED NOTES, MISC. EDITS TO DRAWING, MODIFIED SPACING CHART.  
 REV. 8-1-12: MINOR EDITS TO GENERAL NOTES.  
 REV. 5-6-16: REVISED QUANTITIES TABLE, REVISED GENERAL NOTE (I), REVISED DITCH DETAIL.  
 REV. 11-30-20: REDREW SHEET, REVISED GENERAL NOTE (J) ITEM DESCRIPTION.

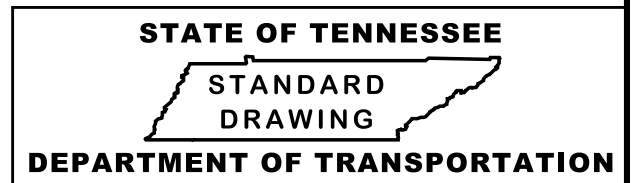

**ROCK CHECK DAM**