

5/1/2023 12:56:19 PM
P:\2022\220072\Infrastructure\Reports\Standard Drawing\New Standard Drawing.dgn

NOT TO SCALE

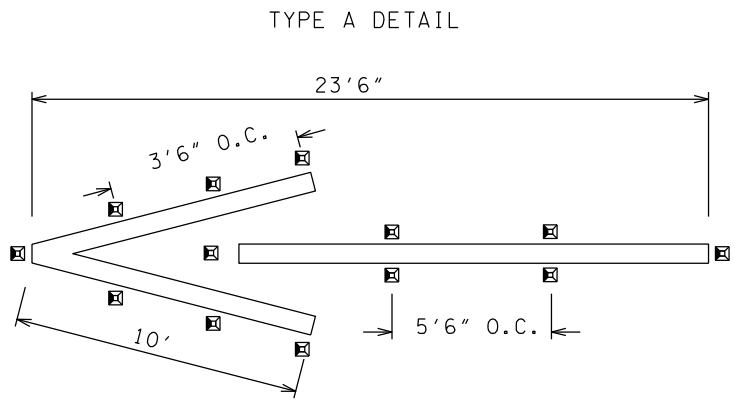

13 BI-DIRECTIONAL RED AND WHITE SPMS

WRONG WAY PAVEMENT ARROW WITH SNOWPLOWABLE PAVEMENT MARKERS TO BE USED ON SINGLE-LANE RAMPS ONLY

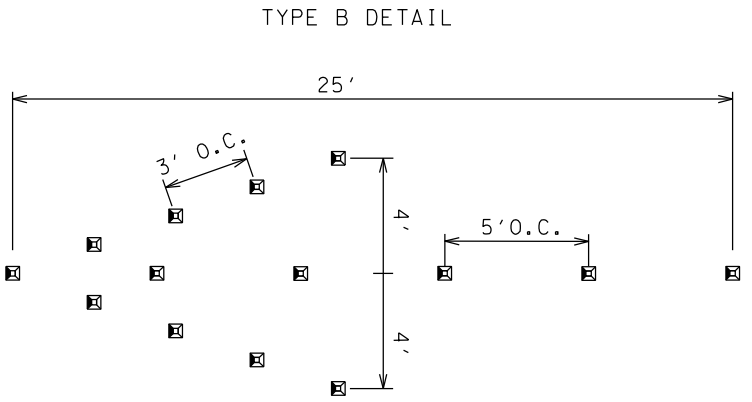

14 MONO-DIRECTIONAL RED ONE-DIRECTIONAL SPMS

WRONG WAY ARROW USING SNOWPLOWABLE PAVEMENT MARKERS TO BE USED ON MULTI-LANE RAMPS ONLY

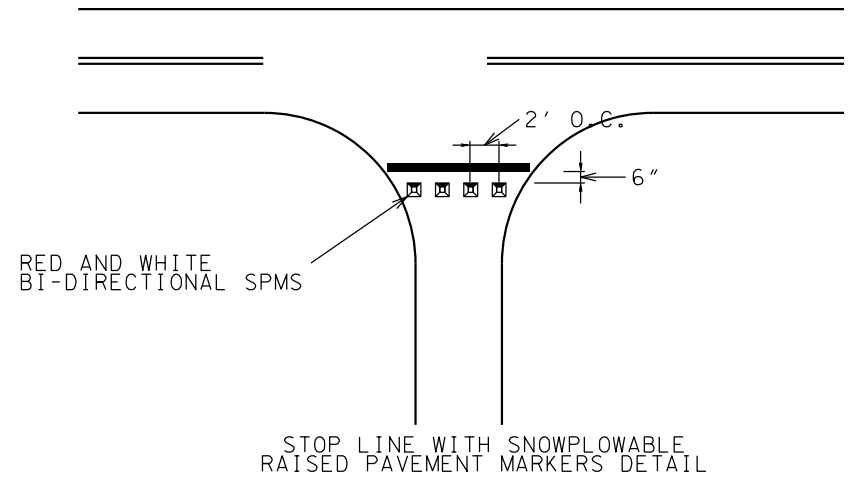

STOP LINE WITH SNOWPLOWABLE RAISED PAVEMENT MARKERS DETAIL

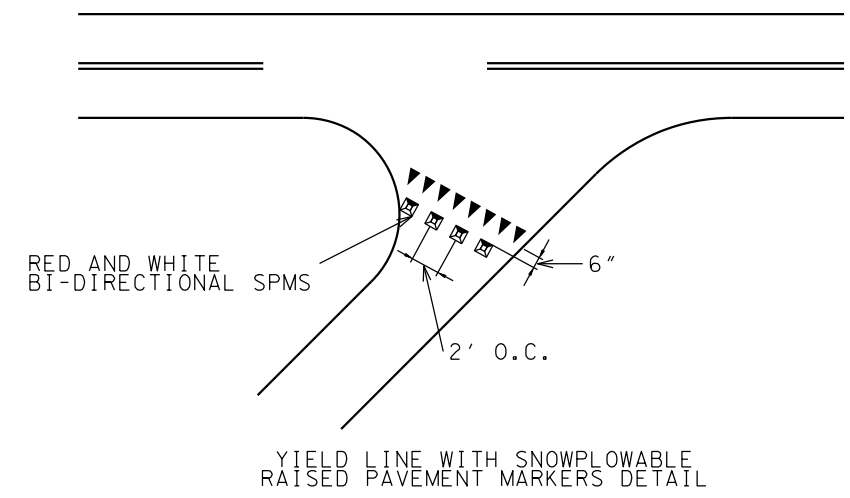

YIELD LINE WITH SNOWPLOWABLE RAISED PAVEMENT MARKERS DETAIL

GENERAL NOTES

- (A) SEE STANDARD DRAWING NO. T-M-9 AND T-M-9A FOR ADDITIONAL DETAILS FOR RAMP SIGNING, STRIPING, AND PAVEMENT MARKERS.

STATE OF TENNESSEE
STANDARD DRAWING
DEPARTMENT OF TRANSPORTATION

PAVEMENT MARKING AND SIGNING DETAILS FOR RAMP INTERSECTIONS

T-M-9B