

3/23/2020 11:28:02 AM  
 C:\Users\jij00547\Desktop\10-102.00 Catch Basins and Manholes IP\102.03 Manholes IP\DMH7-20200220.dgn

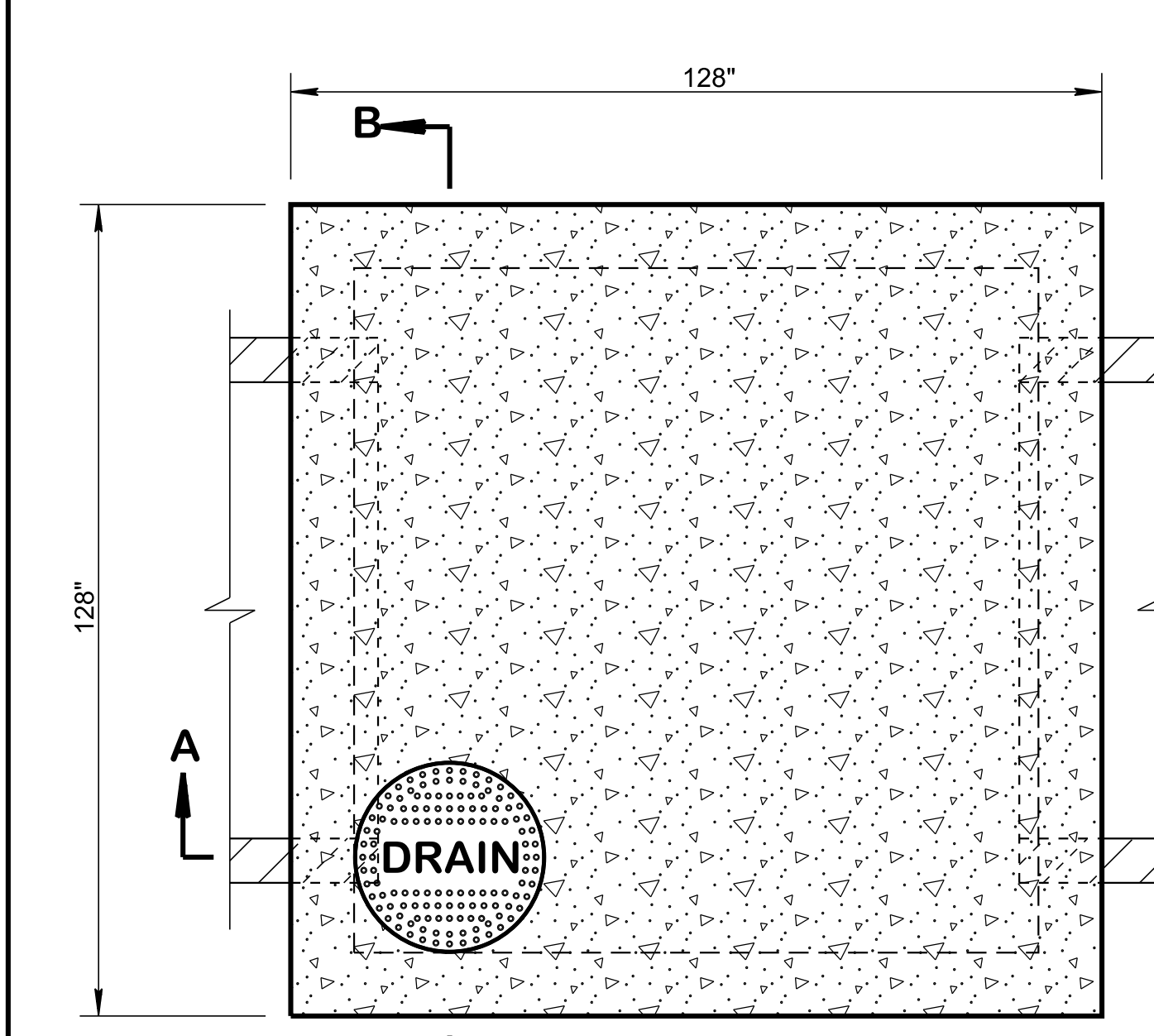

**PLAN VIEW**

**SECTION \*-\***  
 ELEV. VIEW IS PROVIDED ON STANDARD DRAWING D-CB-99 SHOWING REINFORCEMENT REQUIREMENTS AROUND PIPE OPENINGS

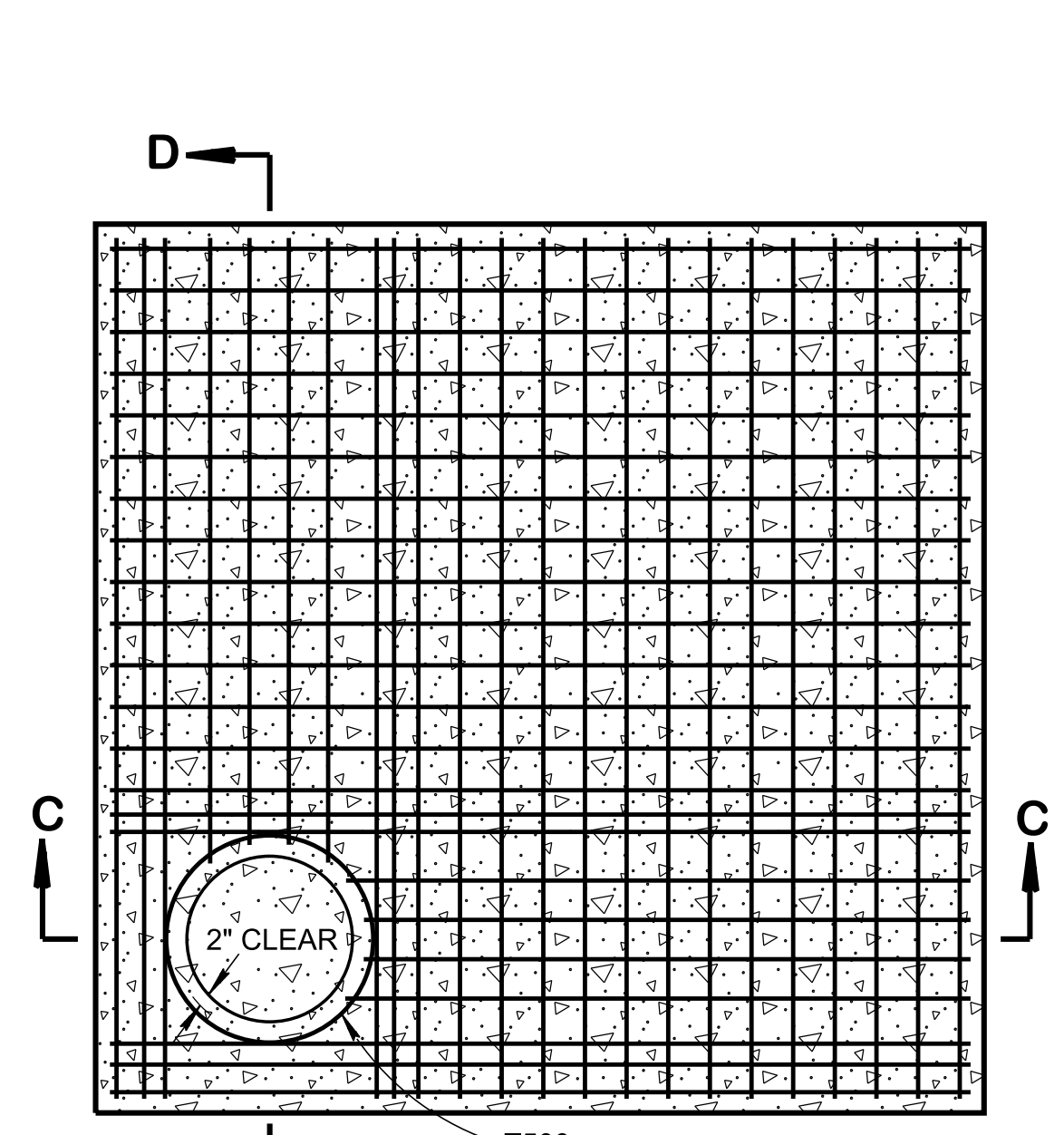

**LID REINFORCING**

A500  
 A500  
 A500  
 A500  
 A500  
 A500  
 A500  
 A500  
 A500  
 A500  
 A500  
 A500  
 A500  
 A500  
 A500  
 A500  
 A500  
 A500  
 A502  
 A502  
 A502  
 A502  
 A500  
 A500  
 A500  
 A500

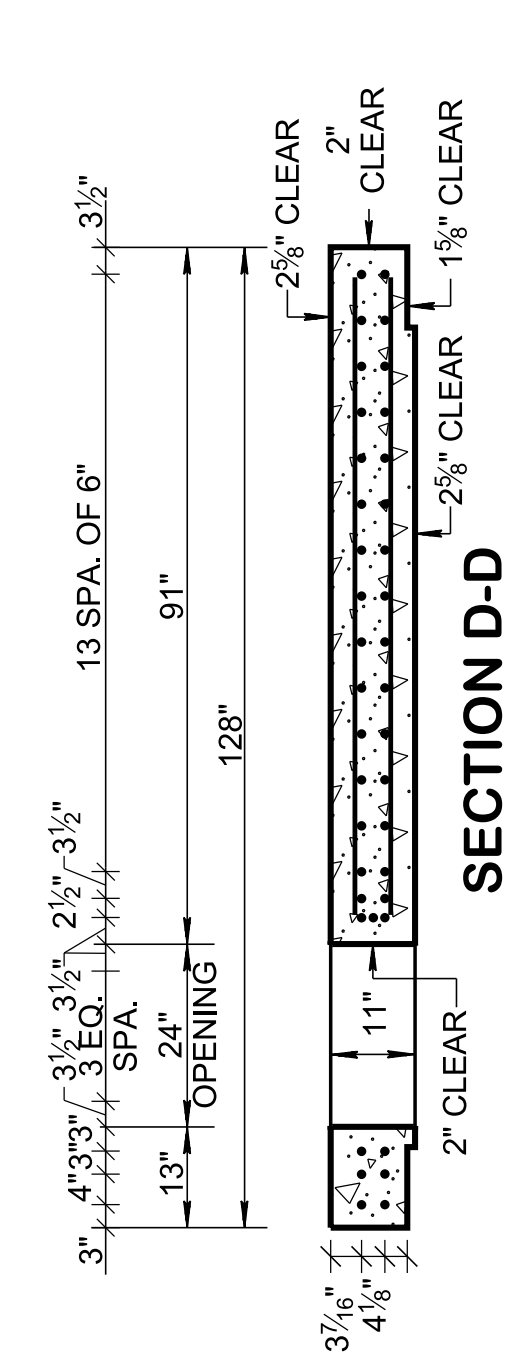

**SECTION D-D**

MANHOLE DIMENSIONS				FOR DESIGN USE ONLY
INSIDE DIAMETER (D) OF PIPE (INCHES)	PIPE WALL THICKNESS (INCHES)	DIAMETER OF CUT-OUT HOLES (INCHES)	BOX SECTION MINIMUM HEIGHTS (INCHES)	MANHOLE MINIMUM DESIGN DEPTH (FEET)
18	2 1/2	25	59 1/2	4.40
24	3	32	66 1/2	4.94
30	3 1/2	39	73 1/2	5.48
36	4	46	80 1/2	6.02
42	4 1/2	53	87 1/2	6.56
48	5	60	94 1/2	7.10
54	5 1/2	67	101 1/2	7.65
60	6	74	108 1/2	8.19
66	6 1/2	81	115 1/2	8.73
72	7	88	122 1/2	9.27
78	7 1/2	95	129 1/2	9.81

- 1 CUT-OUT HOLES BASED ON REINFORCED CONCRETE PIPE WITH WALL TYPE "B".
- 2 ALL FLEXIBLE PIPE MATERIALS REQUIRE GASKET. SEE STANDARD DRAWING D-PB-2.
- 3 CUT-OUT HOLES FOR PRECAST STRUCTURES TO BE FORMED IN ORDER TO OBTAIN A SMOOTH EDGED HOLE. SCORED OR ETCHED HOLES WITH REINFORCING STEEL LEFT UNCUT WILL NOT BE PERMITTED.

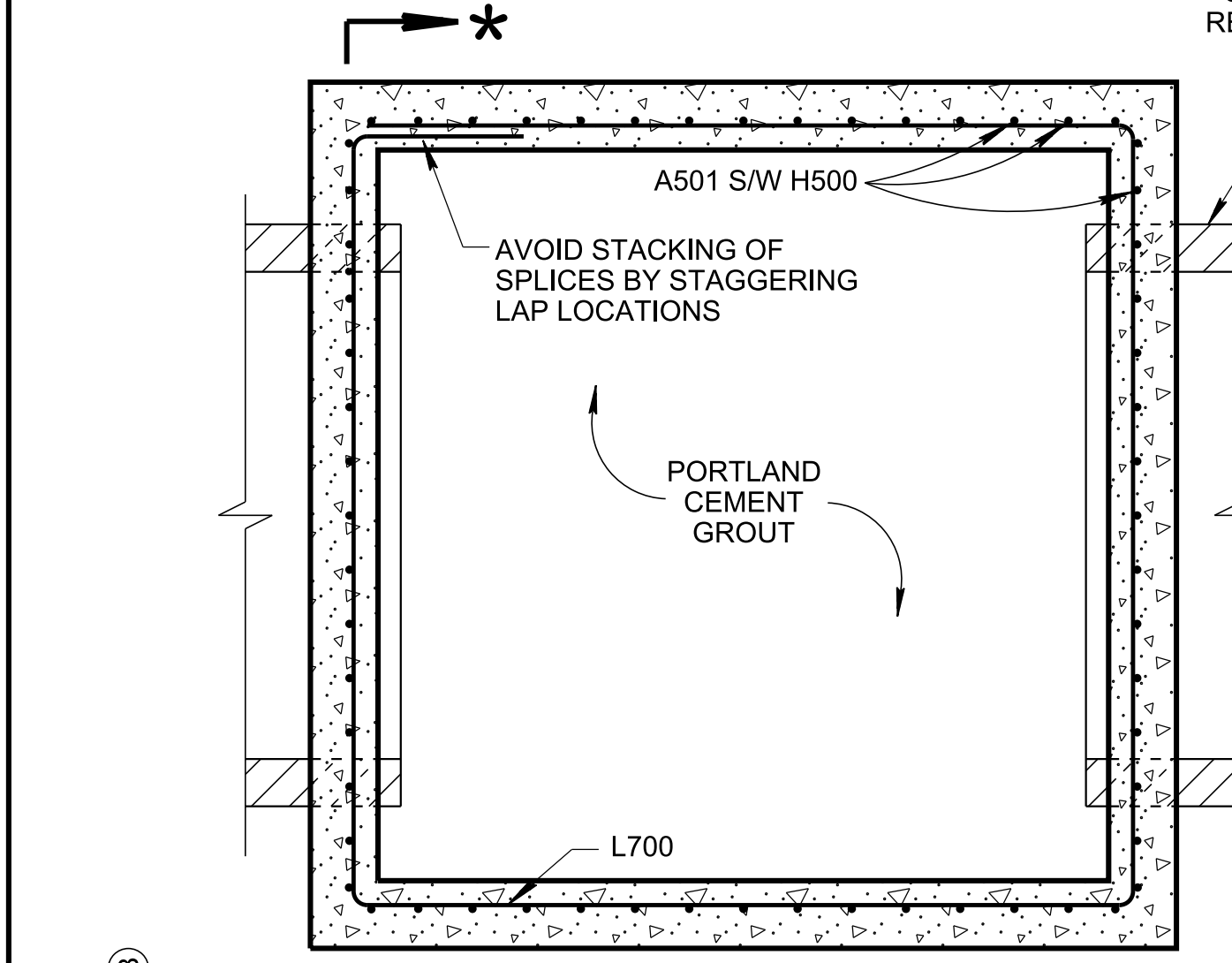

**SECTION E-E**

PIPE (BEYOND)  
 A501 S/W H500  
 AVOID STACKING OF SPLICES BY STAGGERING LAP LOCATIONS  
 PORTLAND CEMENT GROUT  
 L700

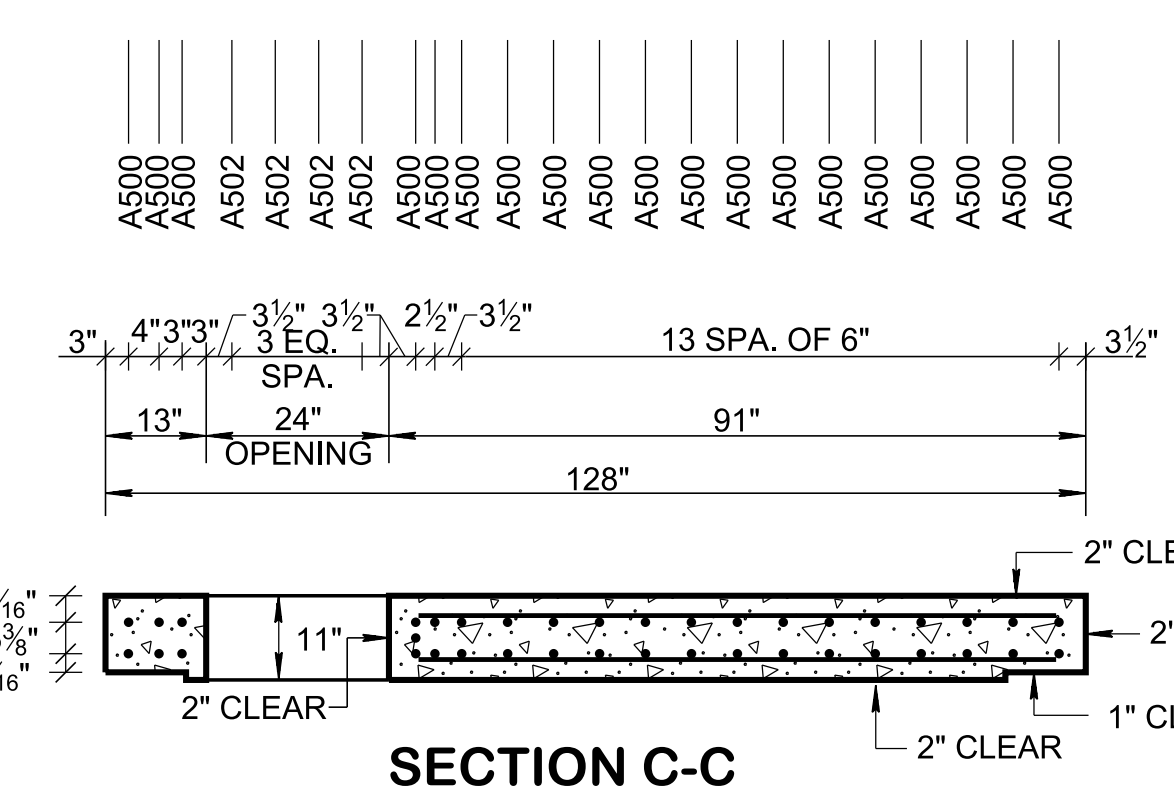

**SECTION C-C**

**MANHOLE MAXIMUM DEPTH NOTE**  
 MAXIMUM DEPTH FOR THIS STRUCTURE IS 28.00'

REINFORCING STEEL LEGEND	
A500	124"
A501	VARIABLE
A502	VARIABLE

DIMENSIONS SHOWN IN THIS LEGEND ARE OUTSIDE TO OUTSIDE OF BAR. STANDARD C.R.S.I. HOOK AND TIE DETAILS SHALL APPLY, EXCEPT AS NOTED.

- GENERAL NOTES**
- (A) DRAWING TO BE USED FOR ALL CAST-IN-PLACE 9' X 9' NO. 3 CONCRETE MANHOLES AND ALL PRECAST 9' X 9' NO. 3 CONCRETE MANHOLES. SEE STANDARD DRAWING D-CB-99 FOR ADDITIONAL CONSTRUCTION NOTES & DETAILS.
  - (B) THIS DIMENSION MAY VARY FROM A MINIMUM OF 0 INCHES TO A MAXIMUM OF 24 INCHES AS LONG AS 26 3/4 INCHES IS SATISFIED. THE CONTRACTOR HAS THE OPTION OF USING BRICK OR STANDARD PRECAST CONCRETE RISER FRAMES. THE USE OF BRICK SHALL BE LIMITED TO 6 INCHES. IF THIS DIMENSION EXCEEDS 6 INCHES, PRECAST CONCRETE RISER FRAMES SHALL BE USED AS SHOWN ON STANDARD DRAWING D-RF-1.
  - (C) THIS DRAWING DEPICTS THE MINIMUM HORIZONTAL REINFORCING AT THE TOP OF MANHOLE WALLS. SEE ADDITIONAL DETAILS ON STANDARD DRAWING D-CB-99 FOR TALLER SECTIONS AND STEEL PLACEMENT ABOVE PIPE OPENINGS.
  - (D) CAST-IN-PLACE MANHOLES SHALL BE CONSTRUCTED IN ACCORDANCE WITH STANDARD SPECIFICATIONS. SECTION 611 AND/OR SPECIAL PROVISIONS UNLESS SUPERSEDED BY THIS DRAWING. THE CONTRACTOR MAY, WITH PERMISSION FROM THE ENGINEER, SUBSTITUTE PRECAST MANHOLES FOR CAST-IN-PLACE MANHOLES PROVIDED THAT ALL PRECAST ELEMENTS MEET ASTM C913 (CURRENT EDITION) UNLESS SUPERSEDED BY THIS DRAWING.
  - (E) THE FOLLOWING MATERIAL PROPERTIES ARE REQUIRED FOR BOTH CAST-IN-PLACE AND PRECAST STRUCTURES:  
 CONCRETE:  $f_c = 4,000$  POUNDS PER SQUARE INCH AT 28 DAYS  
 REINFORCING STEEL: ASTM A615,  $F_y = 60,000$  POUNDS PER SQUARE INCH  
 ALL REINFORCING IS TO BE INSTALLED AS DETAILED ON THIS DRAWING.
  - (F) PRECAST MANHOLE UNITS WHICH ARE DAMAGED DURING SHIPMENT OR INSTALLATION WILL BE REJECTED. IT SHALL BE THE RESPONSIBILITY OF THE CONTRACTOR TO REPLACE DAMAGED MANHOLE UNITS AT THEIR OWN EXPENSE.
  - (G) APPROPRIATE SIZING AND LOCATION OF LIFTING DEVICES SHALL BE THE RESPONSIBILITY OF THE FABRICATOR.
  - (H) THE CONTRACTOR IS TO PATCH ALL LIFTING DEVICE HOLES WITH GROUT AND PLACE A MINIMUM OF ONE (1) INCH OF COVER OVER THE HARDWARE OF THESE DEVICES ON BOTH TOP AND BOTTOM SURFACES.
  - (I) ALTERNATIVE JOINT DETAILS MAY BE ACCEPTABLE. SEE STANDARD DRAWING D-CB-99 FOR ADDITIONAL DETAILS.
  - (J) SEE ROADWAY PLANS DRAINAGE TABULATION FOR PIPE INLET AND OUTLET ELEVATIONS. IF NEEDED, INVERT ELEVATIONS MAY BE ADJUSTED AS DIRECTED BY THE ENGINEER IN ORDER TO ACCOMMODATE INLET AND OUTLET PIPES.
  - (K) FOR CASES WHERE THE OUTLET PIPE DIAMETER IS LARGER THAN THE INLET PIPE DIAMETER, A MINIMUM 26 3/4 INCH DEPTH SHALL BE MAINTAINED ABOVE THE OUTLET PIPE.
  - (L) THE CONTRACTOR MAY ELIMINATE THE A501 BARS BY LENGTHENING THE VERTICAL LEG OF THE H500 BARS SO THAT 1 1/2" OF CLEAR COVER IS PROVIDED AT THE TOP OF THE STRUCTURE.
  - (M) SEE STANDARD DRAWING D-MH-4 FOR DETAILS REGARDING CAST IRON COVERS AND FRAMES, AND DETAILS FOR VARIOUS STEPS.
  - (N) PAY DEPTH MEASUREMENT MADE FROM TOP OF MANHOLE LID TO OUTLET FLOW ELEVATION. PAYMENT INCLUDES RISER SECTION AND LID. PAYMENT FOR MANHOLE WILL BE MADE UNDER ITEM NUMBERS:  
 611-01.02, MANHOLES, > 4'-8" DEPTH, EACH,  
 611-01.07, MANHOLE, > 24'-28" DEPTH, EACH.

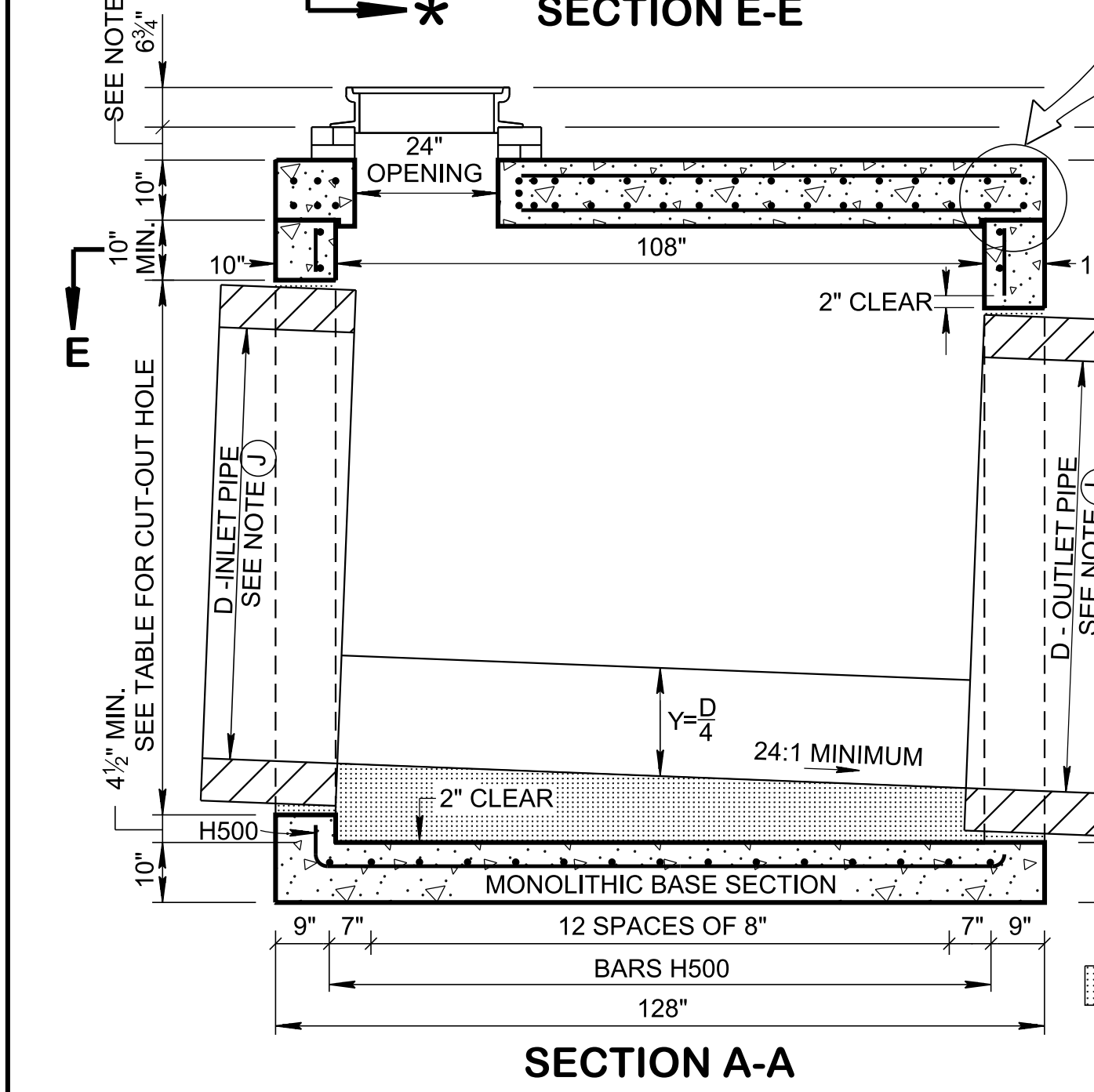

**SECTION A-A**

NON-SHRINK GROUT PER STANDARD SPECIFICATIONS SECTION 918 REQUIRED AROUND PIPE OPENINGS ONLY

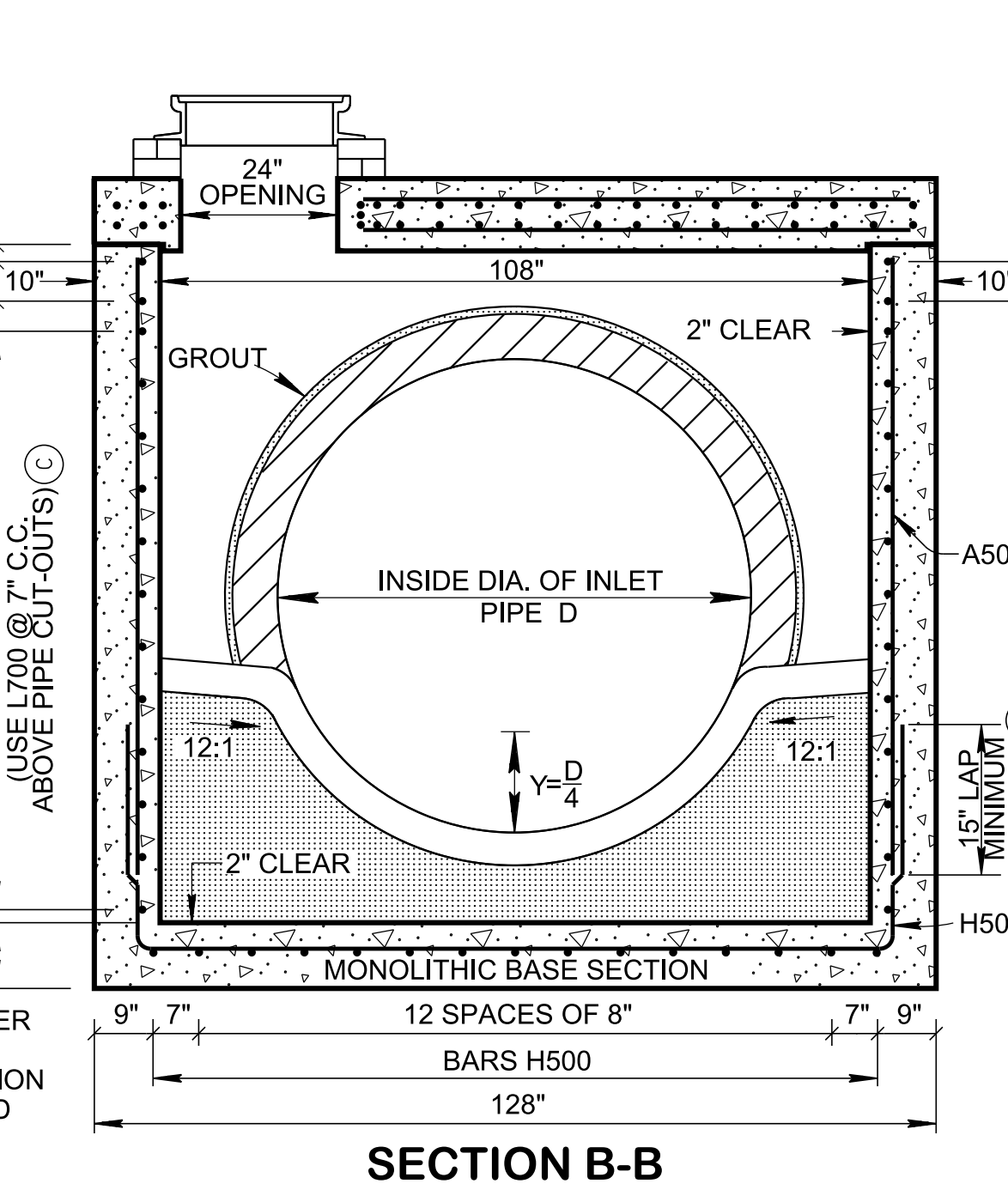

**SECTION B-B**

APPROVED BY FHWA (ALL OTHERS APPROVED BY TDOT)

STATE OF TENNESSEE  
 STANDARD DRAWING  
 DEPARTMENT OF TRANSPORTATION

**STANDARD 9' X 9' SQUARE CONCRETE NO. 3 MANHOLE**

09-05-1998 D-MH-7