

**PLAN VIEW**

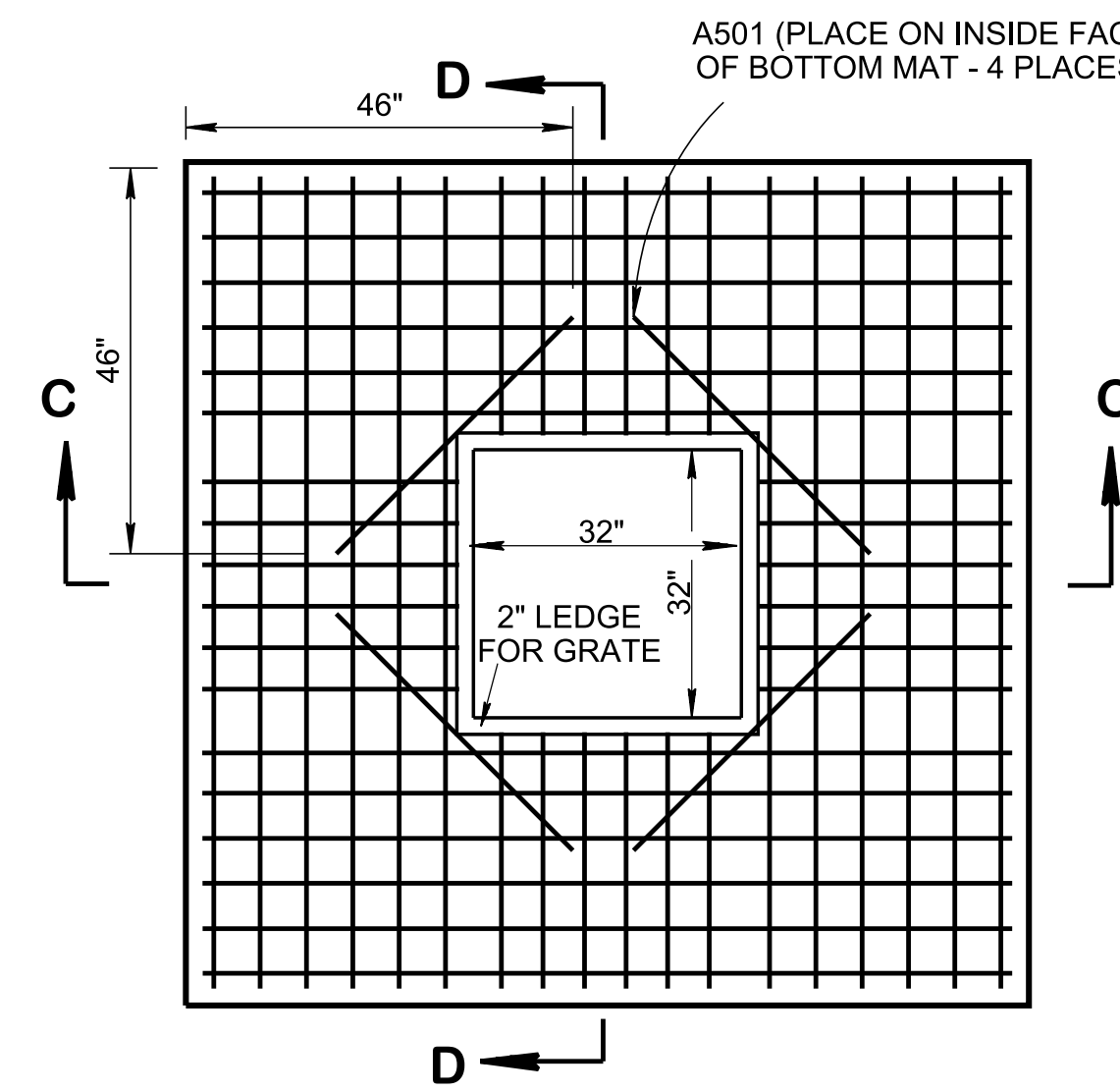

**LID REINFORCING**

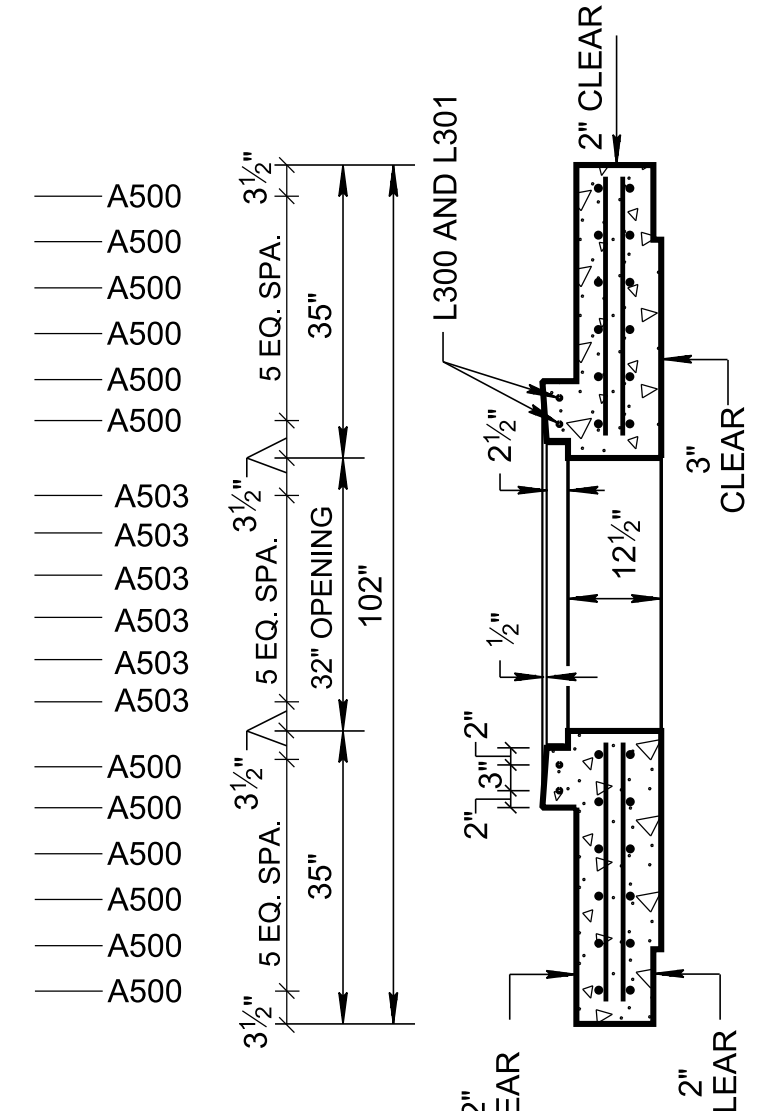

**SECTION D-D**

**CATCH BASIN MAXIMUM DEPTH NOTE**  
 MAXIMUM DEPTH FOR THIS STRUCTURE IS 28.00'.

CATCH BASIN DIMENSIONS				FOR DESIGN USE ONLY CATCH BASIN MINIMUM DESIGN DEPTH (FEET)
INSIDE DIAMETER (D) OF PIPE (INCHES)	PIPE WALL THICKNESS (INCHES)	DIAMETER OF CUT-OUT HOLES (INCHES)	BOX SECTION MINIMUM HEIGHTS (INCHES)	
18	2 1/2	25	62 1/2	4.28
24	3	32	69 1/2	4.82
30	3 1/2	39	76 1/2	5.37
36	4	46	83 1/2	5.91
42	4 1/2	53	90 1/2	6.45
48	5	60	97 1/2	6.99
54	5 1/2	67	104 1/2	7.53
60	6	74	111 1/2	8.08
66	6 1/2	81	118 1/2	8.62

- ① CUT-OUT HOLES BASED ON REINFORCED CONCRETE PIPE WITH WALL TYPE "B".
- ② ALL FLEXIBLE PIPE MATERIALS REQUIRE GASKET. SEE STANDARD DRAWING D-PB-2.
- ③ CUT-OUT HOLES FOR PRECAST STRUCTURES TO BE FORMED IN ORDER TO OBTAIN A SMOOTH EDGED HOLE. SCORED OR ETCHED HOLES WITH REINFORCING STEEL LEFT UNCUT WILL NOT BE PERMITTED.

**SECTION \*-\***

ELEV. VIEW IS PROVIDED ON STANDARD DRAWING D-CB-99 SHOWING REINFORCEMENT REQUIREMENTS AROUND PIPE OPENINGS

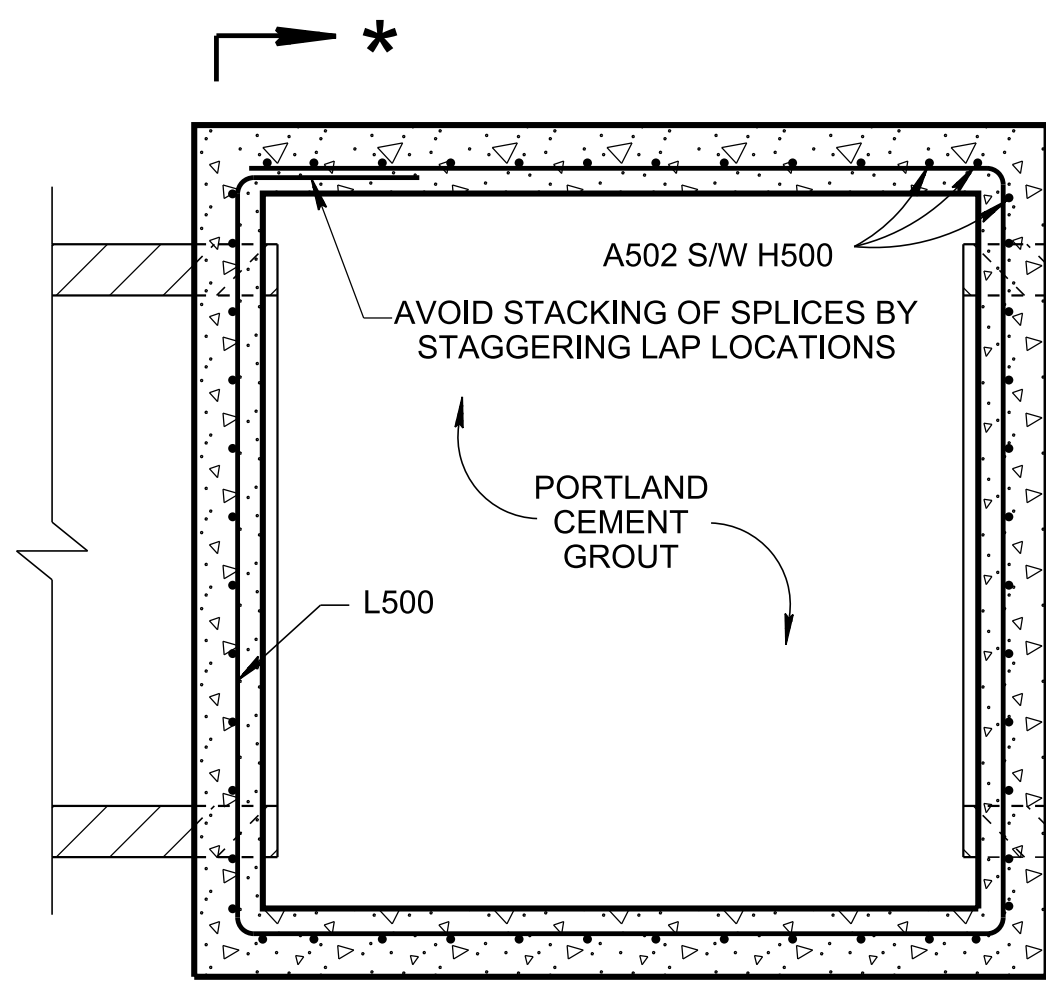

**SECTION E-E**

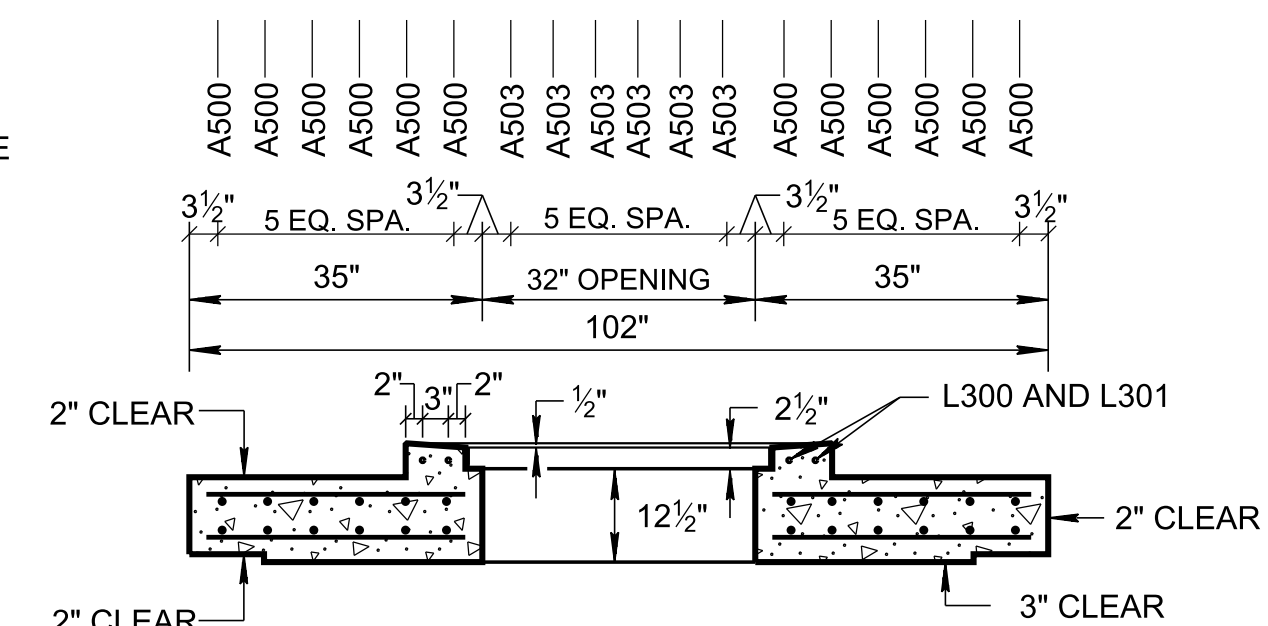

**SECTION C-C**

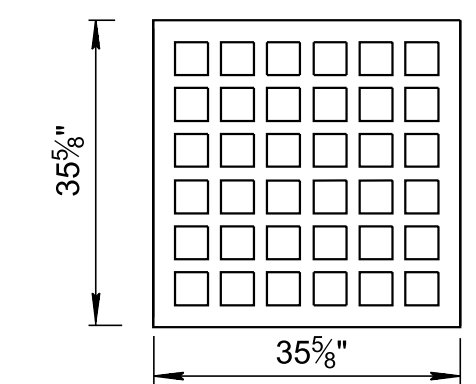

**GRATE UNIT NO. 42**  
 (SEE STD. DWG. D-CBB-42 FOR GRATE DETAILS)

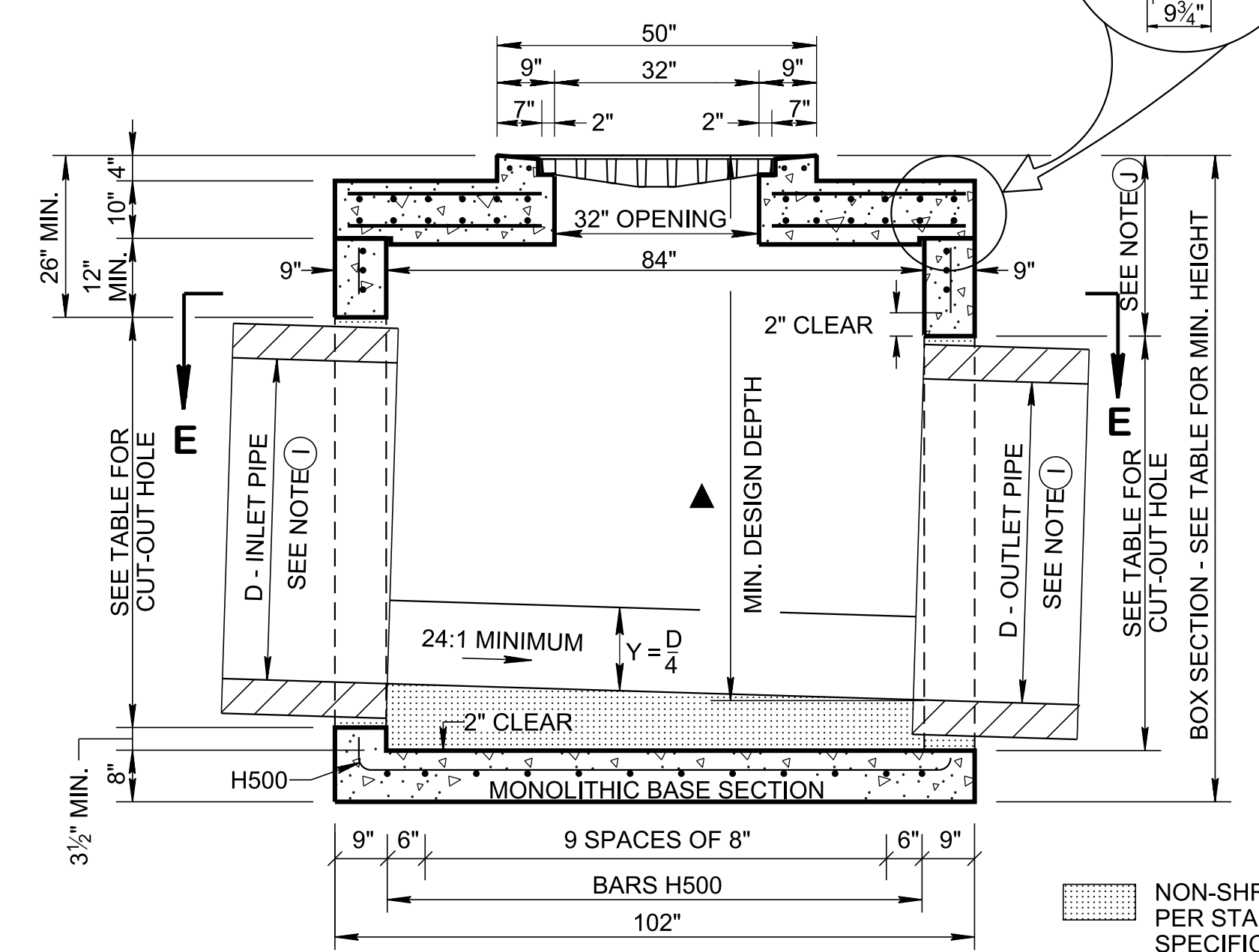

**SECTION A-A**

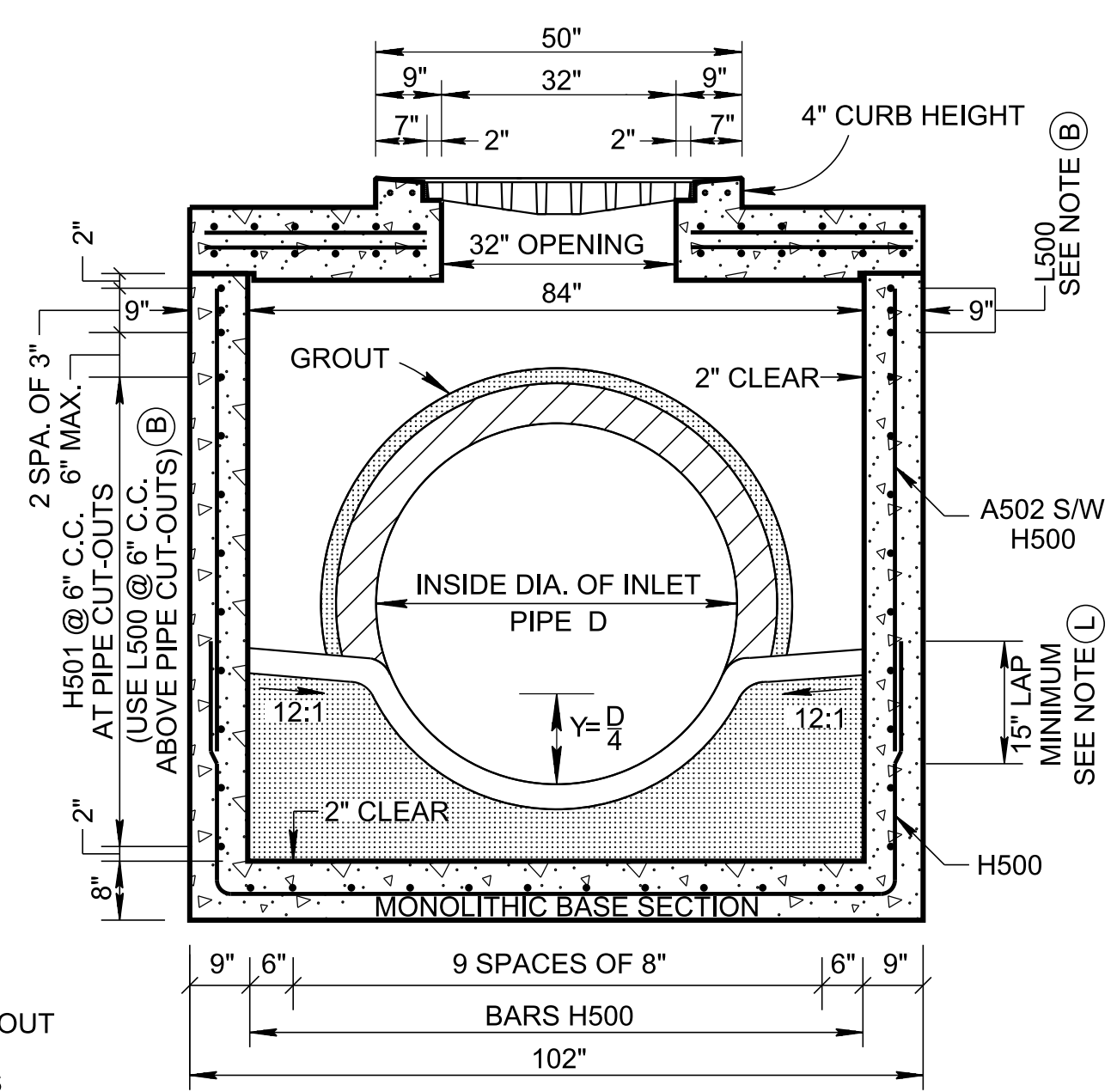

**SECTION B-B**

**REINFORCING STEEL LEGEND**

A500	98"						
A501	40"						
A502	VARIABLE	32"	90 1/2" H500	89 1/4" MAX. 6" MIN. H501	12" 40 3/8" L300	12" 46 3/8" L301	12" 89 1/4" L500
A503	31"						

DIMENSIONS SHOWN IN THIS LEGEND ARE OUTSIDE TO OUTSIDE OF BAR. STANDARD C.R.S.I. HOOK AND TIE DETAILS SHALL APPLY, EXCEPT AS NOTED.

**GENERAL NOTES**

- (A) DRAWING TO BE USED FOR ALL CAST-IN-PLACE NO. 42SD CONCRETE CATCH BASINS AND ALL PRECAST NO. 42SD CONCRETE CATCH BASINS. SEE STANDARD DRAWING D-CB-99 FOR ADDITIONAL CONSTRUCTION NOTES & DETAILS.
- (B) THIS DRAWING DEPICTS THE MINIMUM HORIZONTAL REINFORCING AT THE TOP OF CATCH BASIN WALLS. SEE ADDITIONAL DETAILS ON STANDARD DRAWING D-CB-99 FOR TALLER SECTIONS AND STEEL PLACEMENT ABOVE PIPE OPENINGS.
- (C) CAST-IN-PLACE CONCRETE CATCH BASINS SHALL BE CONSTRUCTED IN ACCORDANCE WITH STANDARD SPECIFICATIONS, SECTION 611 AND/OR SPECIAL PROVISIONS UNLESS SUPERSEDED BY THIS DRAWING. THE CONTRACTOR MAY WITH PERMISSION FROM THE ENGINEER SUBSTITUTE PRECAST CATCH BASINS FOR CAST-IN-PLACE CATCH BASINS PROVIDED THAT ALL PRECAST ELEMENTS MEET ASTM C913 (CURRENT EDITION) UNLESS SUPERSEDED BY THIS DRAWING.
- (D) THE FOLLOWING MATERIAL PROPERTIES ARE REQUIRED FOR BOTH CAST-IN-PLACE AND PRECAST STRUCTURES:  
 CONCRETE:  $f_c = 4,000$  POUNDS PER SQUARE INCH AT 28 DAYS  
 REINFORCING STEEL: ASTM A615,  $F_y = 60,000$  POUNDS PER SQUARE INCH  
 ALL REINFORCING IS TO BE INSTALLED AS DETAILED ON THIS DRAWING.
- (E) PRECAST CATCH BASIN UNITS WHICH ARE DAMAGED DURING SHIPMENT OR INSTALLATION WILL BE REJECTED. IT SHALL BE THE RESPONSIBILITY OF THE CONTRACTOR TO REPLACE DAMAGED CATCH BASIN UNITS AT THEIR OWN EXPENSE.
- (F) APPROPRIATE SIZING AND LOCATION OF LIFTING DEVICES SHALL BE THE RESPONSIBILITY OF THE FABRICATOR.
- (G) THE CONTRACTOR IS TO PATCH ALL LIFTING DEVICE HOLES WITH GROUT AND PLACE A MINIMUM OF ONE (1) INCH OF COVER OVER THE HARDWARE OF THESE DEVICES ON BOTH TOP AND BOTTOM SURFACES.
- (H) ALTERNATIVE JOINT DETAILS MAY BE ACCEPTABLE. SEE STANDARD DRAWING D-CB-99 FOR ADDITIONAL DETAILS.
- (I) SEE ROADWAY PLANS DRAINAGE TABULATION FOR PIPE INLET AND OUTLET ELEVATIONS. IF NEEDED, INVERT ELEVATIONS MAY BE ADJUSTED AS DIRECTED BY THE ENGINEER IN ORDER TO ACCOMMODATE INLET AND OUTLET PIPES.
- (J) FOR CASES WHERE THE OUTLET PIPE DIAMETER IS LARGER THAN THE INLET PIPE DIAMETER, A MINIMUM 26 INCH DEPTH SHALL BE MAINTAINED ABOVE THE OUTLET PIPE.
- (K) SEE STANDARD DRAWING D-CBB-42 FOR DETAILS REGARDING CAST IRON GRATES.
- (L) THE CONTRACTOR MAY ELIMINATE THE A502 BARS BY LENGTHENING THE VERTICAL LEG OF THE H500 BARS SO THAT 1 1/2 INCHES OF CLEAR COVER IS PROVIDED AT THE TOP OF THE STRUCTURE.
- (M) PAY DEPTH MEASUREMENT MADE FROM TOP OF GRATE TO OUTLET FLOW ELEVATION. PAYMENT INCLUDES GRATE. PAYMENT FOR CATCH BASIN WILL BE MADE UNDER ITEM NUMBERS:

611-42.02, CATCH BASINS, TYPE 42, 4'-8" DEPTH, EACH, (THROUGH)  
 611-42.07, CATCH BASINS, TYPE 42, > 24'-28" DEPTH, EACH.

- REV. 9-5-98: CHANGED LENGTH OF REINFORCING BAR DESIGNATED A501.
- REV. 1-19-99: ADDED CURB HEIGHT.
- REV. 5-27-01: CHANGED PAY ITEMS IN GENERAL NOTE ①. ADDED CATCH BASIN MAXIMUM DEPTH NOTE.
- REV. 5-30-02: MODIFIED REINFORCING STEEL.
- REV. 7-29-02: CHANGED ASTM SPECIFICATION IN GENERAL NOTE ③.
- REV. 9-11-02: CHANGED REINFORCING STEEL IN BASE SECTION.
- REV. 8-01-12: REVISED CATCH BASIN FOR COMPLIANCE WITH AASHTO LRFD BRIDGE DESIGN SPECIFICATIONS, 4TH EDITION WITH INTERIMS. REVISED REINFORCING, GENERAL NOTES, LEGEND AND ADDITIONAL MISC. DRAFTING EDITS.
- REV. 9-24-12: MODIFIED TOP SLAB AND MINIMUM DEPTH.
- REV. 3-11-14: ELIMINATED STIRRUPS.
- REV. 05-15-18: REVISED CATCH BASIN MINIMUM DESIGN DEPTH VALUES. CORRECTED STANDARD SPECIFICATIONS SECTION NUMBER TO 921 FOR NON-SHRINK GROUT. ADDED DIMENSION IN SECTION VIEW A-A FOR NOTE ①. CORRECTED REBAR PLACEMENT IN LIDS. ADDED DIMENSION IN SECTION VIEW A-A FOR MINIMUM DESIGN DEPTH. ADJUSTED BOX SECTION MINIMUM HEIGHTS.
- REV. 02-20-2020: REDREW SHEET.

APPROVED BY FHWA  
 (ALL OTHERS APPROVED BY TDOT)

STATE OF TENNESSEE  
 STANDARD DRAWING  
 DEPARTMENT OF TRANSPORTATION

STANDARD  
 7' X 7' SQUARE  
 CONCRETE  
 NO. 42  
 CATCH BASIN