

PLAN VIEW

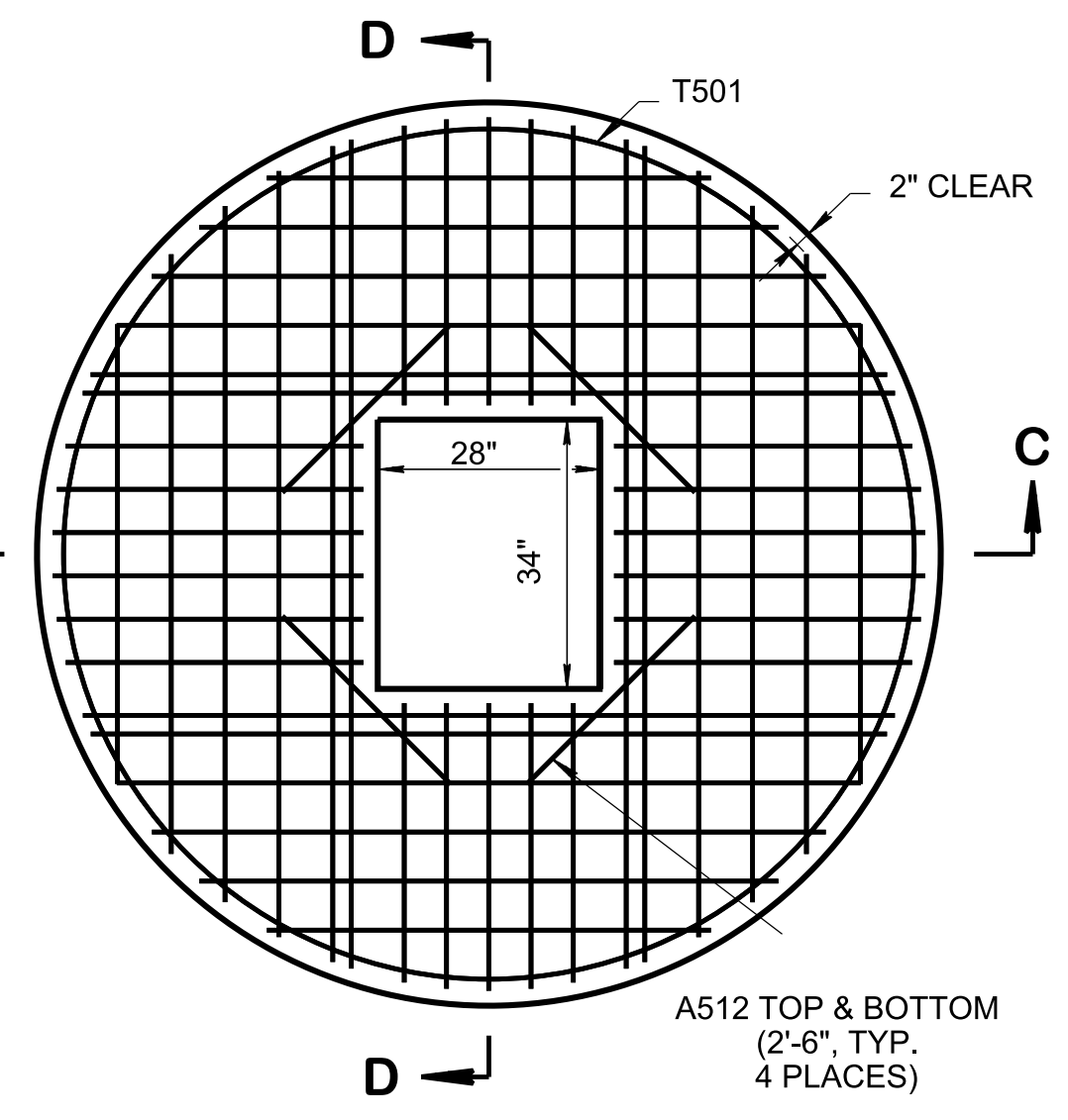

LID REINFORCING

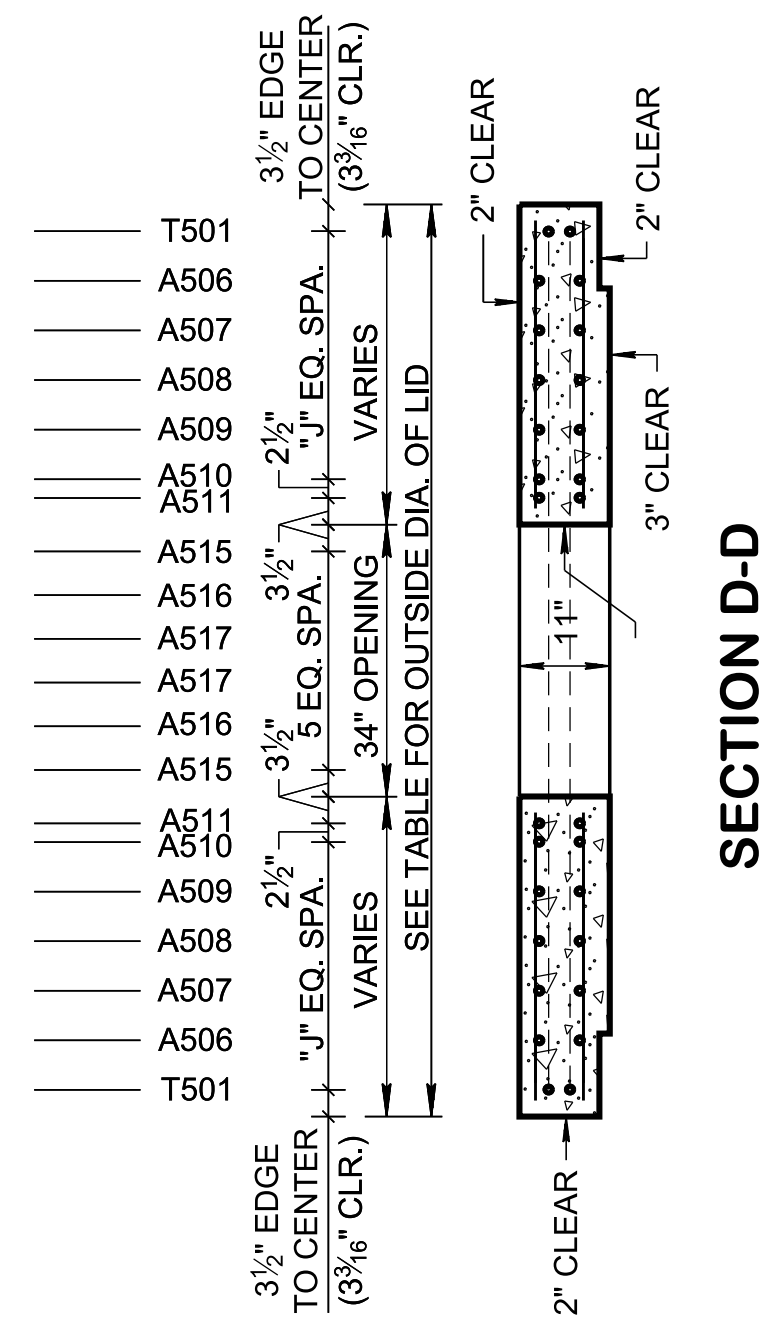

SECTION D-D

SPECIAL NOTE
TO BE USED ON RADIUS LESS THAN 25 FEET. FOR RADIUS 25 FEET AND GREATER USE TYPE 12 CATCH BASIN.

| INSIDE DIAMETER (D) OF PIPE (INCHES) | PIPE WALL THICKNESS (INCHES) | DIAMETER OF CUT-OUT HOLES (INCHES) | PRECAST SECTION MIN. HEIGHTS (INCHES) | | | | FOR DESIGN USE ONLY CATCH BASIN MINIMUM DESIGN DEPTH (FEET) | | | |
|--------------------------------------|------------------------------|------------------------------------|---------------------------------------|-----|---------|------|---|------|------|------|
| | | | 84" | 96" | 108" | 120" | 84" | 96" | 108" | 120" |
| 18 | 2 1/2 | 25 | 58 1/2 | 59 | 63 1/2 | 64 | 4.36 | 4.41 | 4.45 | 4.50 |
| 24 | 3 | 32 | 65 1/2 | 66 | 70 1/2 | 71 | 4.90 | 4.95 | 4.99 | 5.04 |
| 30 | 3 1/2 | 39 | 72 1/2 | 73 | 77 1/2 | 78 | 5.45 | 5.49 | 5.54 | 5.58 |
| 36 | 4 | 46 | 79 1/2 | 80 | 84 1/2 | 85 | 5.99 | 6.03 | 6.08 | 6.12 |
| 42 | 4 1/2 | 53 | 86 1/2 | 87 | 91 1/2 | 92 | 6.53 | 6.57 | 6.62 | 6.66 |
| 48 | 5 | 60 | 93 1/2 | 94 | 98 1/2 | 99 | 7.07 | 7.12 | 7.16 | 7.21 |
| 54 | 5 1/2 | 67 | 100 1/2 | 101 | 105 1/2 | 106 | 7.61 | 7.66 | 7.70 | 7.75 |
| 60 | 6 | 74 | 107 1/2 | 108 | 112 1/2 | 113 | 8.15 | 8.20 | 8.25 | 8.29 |
| 66 | 6 1/2 | 81 | 114 1/2 | 115 | 119 1/2 | 120 | 8.70 | 8.74 | 8.79 | 8.83 |
| 72 | 7 | 88 | 121 1/2 | 122 | 126 1/2 | 127 | 9.24 | 9.28 | 9.33 | 9.37 |
| 78 | 7 1/2 | 95 | 128 1/2 | 129 | 133 1/2 | 134 | 9.78 | 9.83 | 9.87 | 9.92 |

- ① CUT-OUT HOLES BASED ON REINFORCED CONCRETE PIPE WITH WALL TYPE "B".
- ② ALL FLEXIBLE PIPE MATERIALS REQUIRE GASKET. SEE STANDARD DRAWING D-PB-2.
- ③ CUT-OUT HOLES FOR PRECAST STRUCTURES TO BE FORMED IN ORDER TO OBTAIN A SMOOTH EDGED HOLE. SCORED OR ETCHED HOLES WITH REINFORCING STEEL LEFT UN CUT WILL NOT BE PERMITTED.

VARIABLE REINFORCING DIMENSIONS AND SPACING IN CONCRETE LID

| INSIDE DIA. OF CATCH BASIN (INCHES) | OUTSIDE DIA. OF LID (INCHES) | NO. OF EQUAL SPACES "J" |
|-------------------------------------|------------------------------|-------------------------|
| 84 | 100 | 5 |
| 96 | 114 | 6 |
| 108 | 128 | 7 |
| 120 | 142 | 8 |

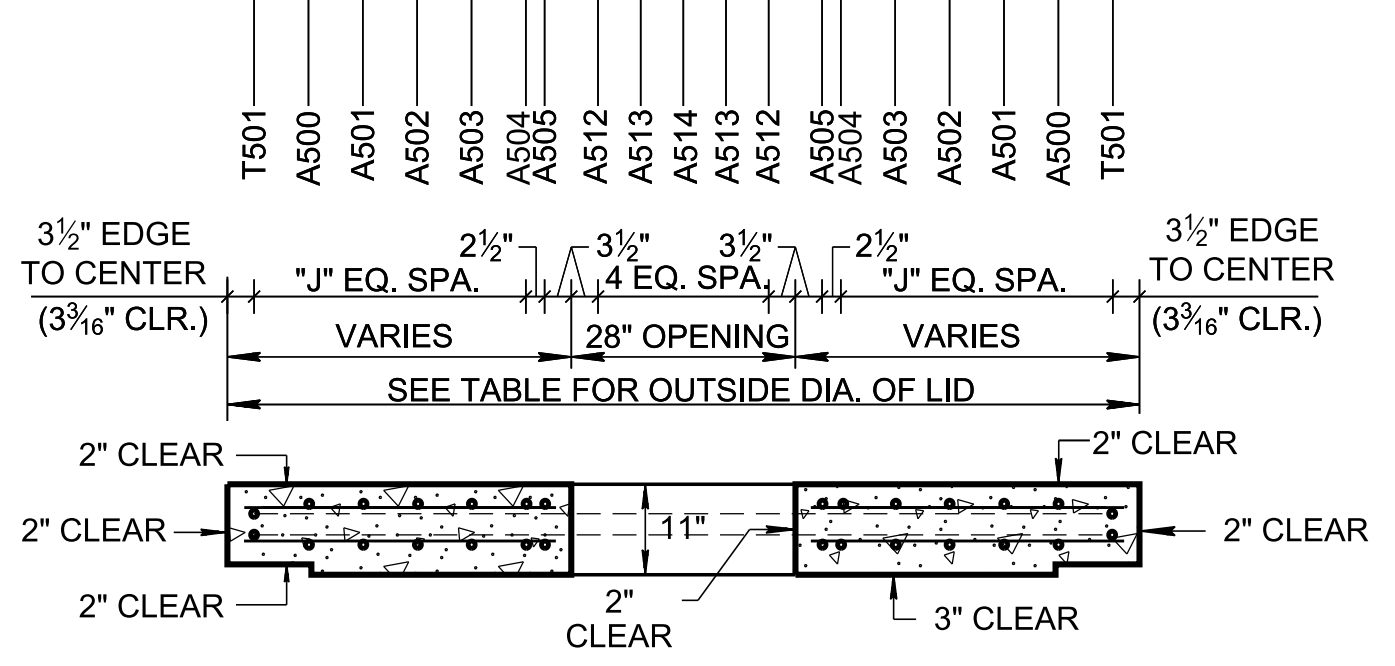

SECTION C-C

CATCH BASIN DIMENSIONS

| INSIDE DIA. OF CATCH BASIN D (INCHES) | WALL THICKNESS W (INCHES) | LID THICKNESS L (INCHES) | BASE THICKNESS U (INCHES) | OUTSIDE DIA. OF CATCH BASIN D + 2W (INCHES) | MAX. INLET OR OUTLET CONC. PIPE SIZE - STR. (INCHES) | MAX. INLET OR OUTLET CONC. PIPE SIZE - 90 (INCHES) | DIMENSION | |
|---------------------------------------|---------------------------|--------------------------|---------------------------|---|--|--|------------|------------|
| | | | | | | | C (INCHES) | H (INCHES) |
| 84 | 8 | 10 | 8 | 100 | 60 | 36 | 3.5 | 12 |
| 96 | 9 | 10 | 8 | 114 | 66 | 42 | 4.0 | 12 |
| 108 | 10 | 10 | 12 | 128 | 72 | 48 | 4.5 | 12 |
| 120 | 11 | 10 | 12 | 142 | 78 | 54 | 5.0 | 12 |

OUT-TO-OUT DIAMETER FOR T501 REINFORCING BARS EQUALS OUTSIDE DIAMETER OF LID MINUS 6 3/8 INCHES. ADDITIONAL A-BARS ARE REQUIRED FOR THE LARGER STRUCTURES AS INDICATED BY "NO. OF EQ. SPACES 'J'"

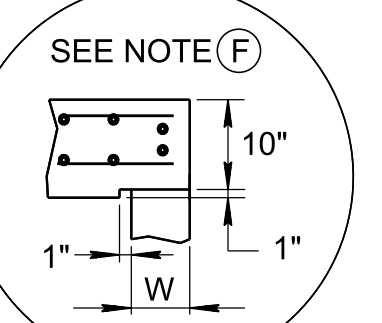

SEE NOTE (F)

CATCH BASIN MAXIMUM DEPTH NOTE
MAXIMUM DEPTH FOR THIS STRUCTURE IS 40.00'.

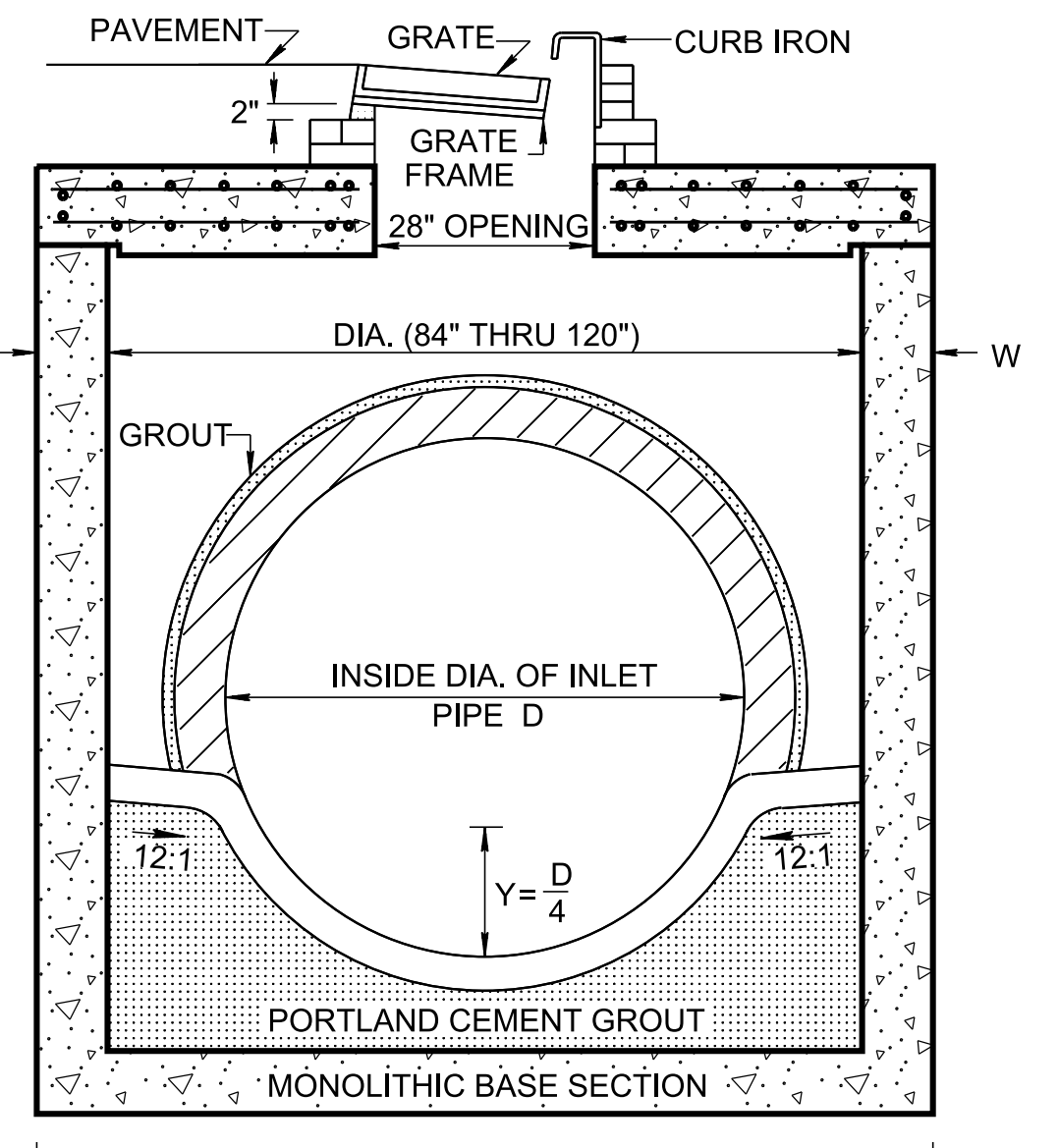

SECTION B-B

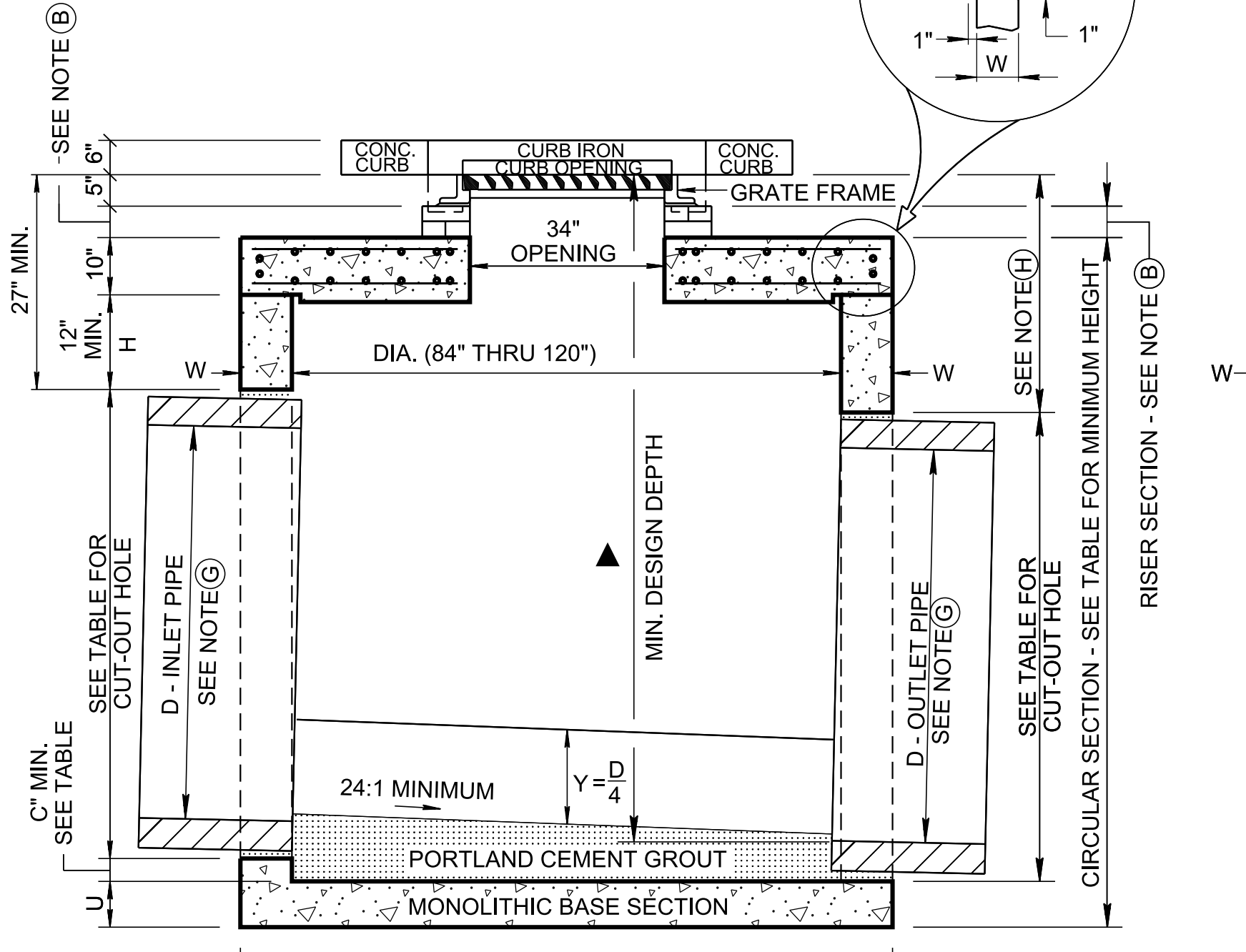

SECTION A-A

NON-SHRINK GROUT PER STANDARD SPECIFICATIONS SECTION 921 REQUIRED AROUND PIPE OPENINGS ONLY

GENERAL NOTES

- (A) ALL PRECAST ELEMENTS TO MEET ASTM C478 (CURRENT EDITION) AND AASHTO M199 (CURRENT EDITION) UNLESS SUPERSEDED BY THIS DRAWING.
CONCRETE: $f'_c = 4,000$ POUNDS PER SQUARE INCH AT 28 DAYS
REINFORCING STEEL: ASTM A615, $F_y = 60,000$ POUNDS PER SQUARE INCH
ALL REINFORCING IS TO BE INSTALLED AS DETAILED ON THIS DRAWING.
- (B) THIS DIMENSION MAY VARY FROM A MINIMUM OF 0 INCHES TO A MAXIMUM OF 24 INCHES AS LONG AS 27 INCHES IS SATISFIED. THE CONTRACTOR HAS THE OPTION OF USING BRICK OR STANDARD PRECAST CONCRETE RISER FRAMES. THE USE OF BRICK SHALL BE LIMITED TO 6 INCHES. IF THIS DIMENSION EXCEEDS 6 INCHES, PRECAST CONCRETE RISER FRAMES SHALL BE USED AS SHOWN ON STANDARD DRAWING D-RF-1.
- (C) PRECAST CATCH BASIN UNITS WHICH ARE DAMAGED DURING SHIPMENT OR INSTALLATION WILL BE REJECTED. IT SHALL BE THE RESPONSIBILITY OF THE CONTRACTOR TO REPLACE DAMAGED CATCH BASIN UNITS AT THEIR OWN EXPENSE.
- (D) APPROPRIATE SIZING AND LOCATION OF LIFTING DEVICES SHALL BE THE RESPONSIBILITY OF THE FABRICATOR.
- (E) THE CONTRACTOR IS TO PATCH ALL LIFTING DEVICE HOLES WITH GROUT AND PLACE A MINIMUM OF ONE (1) INCH OF COVER OVER THE HARDWARE OF THESE DEVICES ON BOTH TOP AND BOTTOM SURFACES.
- (F) ALTERNATIVE JOINT DETAILS MAY BE ACCEPTABLE. SEE STANDARD DRAWING D-CB-99R FOR ADDITIONAL DETAILS.
- (G) SEE ROADWAY PLANS DRAINAGE TABULATION FOR PIPE INLET AND OUTLET ELEVATIONS. INVERT ELEVATIONS ARE TO BE ADJUSTED AS DIRECTED BY THE ENGINEER IN ORDER TO ACCOMMODATE INLET AND OUTLET PIPES.
- (H) FOR CASES WHERE THE OUTLET PIPE DIAMETER IS LARGER THAN THE INLET PIPE DIAMETER, A MINIMUM 27 INCH DEPTH SHALL BE MAINTAINED ABOVE THE OUTLET PIPE.
- (I) SEE STANDARD DRAWING D-CBB-13 FOR DETAILS REGARDING CAST IRON GRATES, FRAMES AND CURB INLETS.
- (J) SEE STANDARD DRAWING D-CB-13RA FOR DETAILS REGARDING 48" CIRCULAR NO. 13 CATCH BASIN (FOR USE WITH 6" VERTICAL CURB).
- (K) SEE STANDARD DRAWING D-CB-13RB FOR DETAILS REGARDING 60" AND 72" CIRCULAR NO. 13 CATCH BASIN (FOR USE WITH 6" VERTICAL CURB).
- (L) PAY DEPTH MEASUREMENT MADE FROM TOP OF GRATE TO OUTLET FLOW ELEVATION. PAYMENT INCLUDES RISER SECTION AND GRATE. PAYMENT FOR CATCH BASIN WILL BE MADE UNDER ITEM NUMBERS:
611-13.02, CATCH BASINS, TYPE 13, > 4'-8" DEPTH, EACH, (THROUGH)
611-13.07, CATCH BASINS, TYPE 13, > 24'-28" DEPTH, EACH.
PAYMENT FOR CATCH BASINS DEEPER THAN 28' WILL BE MADE UNDER ITEM NUMBER:
611-13.08, CATCH BASINS, TYPE 13, > (' - ' DEPTH), EACH.

REV. 5-27-01: CHANGED PAY ITEMS IN GENERAL NOTE (L). ADDED CATCH BASIN MAXIMUM DEPTH NOTE.

REV. 8-01-12: REVISED CATCH BASIN LID FOR COMPLIANCE WITH AASHTO LRFD BRIDGE DESIGN SPECIFICATIONS, 4TH EDITION WITH INTERIMS. REVISED REINFORCING, GENERAL NOTES AND ADDITIONAL MISC. DRAFTING EDITS.

REV. 9-24-12: MODIFIED TOP SLAB AND MINIMUM DEPTH.

REV. 3-11-14: ELIMINATED STIRRUPS.

REV. 05-15-18: REVISED CATCH BASIN MINIMUM DESIGN DEPTH VALUES. CORRECTED STANDARD SPECIFICATIONS SECTION NUMBER TO 921 FOR NON-SHRINK GROUT. ADDED DIMENSION IN SECTION VIEW A-A FOR NOTE (B). CORRECTED REBAR PLACEMENT IN LIDS. ADDED DIMENSION IN SECTION VIEW A-A FOR MINIMUM DESIGN DEPTH. CHANGED TO "VERTICAL CURB" FROM "NONMOUNTABLE CURB". ADJUSTED BOX SECTION MINIMUM HEIGHTS.

REV. 02-20-2020: REDREW SHEET.

APPROVED BY FHWA (ALL OTHERS APPROVED BY TDOT)

STATE OF TENNESSEE
STANDARD DRAWING
DEPARTMENT OF TRANSPORTATION

**SRANDARD PRECAST
84"THRU120"CIRCULAR
NO. 13 CATCH BASIN
FOR USE WITH 6"
VERTICAL CURB**