

PDN - CHAPTER 2

GEOMETRIC

DESIGN CRITERIA

CHAPTER 2 GEOMETRIC DESIGN CRITERIA

Table of Contents

INTRODUCTION.....	1
SECTION 1 – CONTROLLING GEOMETRIC DESIGN CRITERIA	3
2-100.00 CONTROLLING CRITERIA FOR DESIGN	3
2-101.00 HORIZONTAL DESIGN	3
2-101.01 HORIZONTAL CURVE RADIUS AND SUPERELEVATION RATES	3
2-101.02 TRAVEL, THROUGH, AND TURN LANE WIDTHS	5
2-101.03 SHOULDER WIDTHS	5
2-101.04 CROSS SLOPES	6
2-102.00 VERTICAL DESIGN.....	6
2-102.01 VERTICAL GRADES	7
2-102.02 STOPPING SIGHT DISTANCE	7
2-102.03 STOPPING SIGHT DISTANCE ON HORIZONTAL AND VERTICAL INTERSECTIONS	7
2-102.04 STOPPING SIGHT DISTANCE ON HORIZONTAL AND VERTICAL CURVES.....	7
2-102.05 VERTICAL CLEARANCES FOR BRIDGES.....	9
2-103.00 DESIGN SPEED	10
2-104.00 DESIGN LOADING STRUCTURAL CAPACITY	10
2-105.00 DESIGN EXCEPTION REQUESTS.....	10
SECTION 2 – NON-CONTROLLING GEOMETRIC DESIGN CRITERIA	13
2-200.00 NON-CONTROLLING GEOMETRIC DESIGN CRITERIA.....	13
2-200.01 PASSING SIGHT DISTANCE.....	13
2-200.02 VERTICAL CURVES	13
2-200.03 ROADSIDE SLOPE DEVELOPMENT	14
2-200.04 CLEAR ZONE.....	15
2-200.05 DESIGN VEHICLE	16
2-200.06 MULTIMODAL FACILITIES	17
2-201.00 DESIGN WAIVER REQUESTS.....	17
SECTION 3 – ROADSIDE DESIGN CRITERIA.....	18
2-300.00 ROADSIDE DESIGN CRITERIA	18
2-301.00 CLEAR ZONE CONCEPT.....	18
2-302.00 ROADSIDE BARRIERS.....	19
2-302.01 BARRIER WARRANT 1: AT BRIDGES OR CULVERTS.....	19
2-302.02 BARRIER WARRANT 2: NON-TRAVERSABLE SLOPES	20

**TDOT ROADWAY DESIGN GUIDELINES – PDN
CHAPTER 2 GEOMETRIC DESIGN CRITERIA**

English

Revised:

2-302.03	BARRIER WARRANT 3: ROADSIDE OBSTACLES	24
2-302.04	BARRIER WARRANT 4: FREEWAY MEDIAN DEPARTURES	25
2-302.05	EXCEPTIONS TO BARRIER WARRANTS	25
2-302.06	BARRIER LENGTH OF NEED	26
2-302.07	BARRIER TYPE SELECTION CRITERIA	26
2-303.00	GUARDRAIL.....	27
2-303.01	GUARDRAIL SPECIAL DESIGNS.....	28
2-304.00	CONCRETE MEDIAN BARRIERS.....	29
2-305.00	CABLE BARRIERS	29
2-306.00	END TREATMENTS	30
2-306.01	ANCHORAGES.....	30
2-306.02	GUARDRAIL END TERMINALS	31
2-307.00	CRASH CUSHIONS.....	31
2-307.01	CRASH CUSHION WORK ENERGY PRINCIPLE (NON-GATING, RE-DIRECTIVE SYSTEMS)	32
2-307.02	CRASH CUSHION CONSERVATION OF MOMENTUM PRINCIPLE (GATING SYSTEMS)	33
2-307.03	CRASH CUSHION SELECTION GUIDELINES.....	33
2-307.04	CRASH CUSHION SELECTION BASED ON SITE CHARACTERISTICS	34
2-307.05	CRASH CUSHIONS IN TEMPORARY WORK ZONES.....	35
2-308.00	CHECKING DRAINAGE PLANS PRIOR TO CONSTRUCTION	36
SECTION 4 – SIGNS		37
2-400.00	ROADWAY SIGNING SHEETS DEVELOPMENT GUIDELINES.....	37
2-401.00	ADVANCE GUIDE SIGNS AND EXIT DIRECTIONAL SIGNS ON TRAFFIC CONTROL PLANS	39
2-402.00	HISTORICAL MARKERS	41
SECTION 5 – PAVEMENT MARKINGS.....		42
2-500.00	PAVEMENT MARKING GUIDELINES.....	42
2-501.00	TEMPORARY PAVEMENT MARKINGS.....	42
2-501.01	TEMPORARY PAVEMENT MARKING FOR USE ON PAVEMENT SURFACE OTHER THAN FINAL.....	43
2-502.00	PERMANENT PAVEMENT MARKINGS.....	45
2-503.00	RUMBLE STRIPS	50
2-503.01	TYPES OF RUMBLE STRIPS	51
2-504.00	RUMBLE STRIPES.....	52
2-505.00	MUMBLE STRIPES	53
2-506.00	SAFETY EDGE.....	53

**TDOT ROADWAY DESIGN GUIDELINES – PDN
CHAPTER 2 GEOMETRIC DESIGN CRITERIA**

English	Revised:
2-507.00 FLEXIBLE DELINEATORS.....	53
2-508.00 SPECIALTY PAVEMENT MARKINGS	54
2-509.00 USE OF REMOVABLE PAVEMENT MARKING LINE.....	54
2-510.00 SNOWPLOWABLE RAISED PAVEMENT MARKERS	54
SECTION 6 – INTERSECTIONS	56
2-600.00 INTERSECTIONS	56
2-601.00 LANE DROP AFTER INTERSECTION	56
2-602.00 TURNING LANES AT INTERSECTIONS.....	60
2-603.00 J-TURN INTERSECTIONS.....	61
2-604.00 INTERSECTIONS LOCATED NEAR THE LIMITS OF CONSTRUCTION	62
SECTION 7 – INTERCHANGES	63
2-700.00 INTERCHANGES.....	63
2-700.01 INTERCHANGE RAMP DESIGN	64
2-700.02 TWO-LANE ENTRANCE RAMPS ON FREEWAYS AND EXPRESSWAYS.....	64
2-700.03 ACCESS CONTROL AT INTERCHANGE RAMPS	65
SECTION 8 – MEDIANS.....	66
2-800.00 MEDIANS	66
2-800.01 MEDIAN OPENING SPACING	66
2-800.02 MEDIAN OPENING SPACING - EXAMPLES	66
2-800.03 LEFT TURN LANES IN MEDIANS	66
SECTION 9 – RETAINING WALL DESIGN	68
2-900.00 RETAINING WALLS.....	68
2-900.01 RETAINING WALL SHEET NAMES, NUMBER, AND ORDER IN PLANS	68
2-900.02 DEVELOP THE RETAINING WALL GEOMETRIC LAYOUT SHEET	70
2-900.03 RETAINING WALL ASSESSMENT AT SITE REVIEW	78
2-900.04 GUIDELINES FOR CATEGORY ONE RETAINING WALLS.....	79
2-900.05 GUIDELINES FOR CATEGORY TWO RETAINING WALLS	80
2-900.06 DECORATIVE FACING ON RETAINING WALLS	81
2-900.07 RETAINING WALL QUANTITIES	81
2-900.08 R.O.W. FUNDING REQUEST AND R.O.W. REVISIONS	83
2-900.09 PS&E FIELD REVIEW, SUBMITTAL, AND REVISIONS	83
2-900.10 RETAINING WALL FOOTNOTES ON PS&E PLANS.....	83
2-900.11 RETAINING WALL BARRIER SYSTEM REQUIREMENTS.....	84
SECTION 10 – EARTHWORK DESIGN	86
2-1000.00 EARTHWORK CONSIDERATIONS.....	86

**TDOT ROADWAY DESIGN GUIDELINES – PDN
CHAPTER 2 GEOMETRIC DESIGN CRITERIA**

English	Revised:
2-1001.00 EARTHWORK BALANCES ON WIDENING OF EXISTING ROADWAYS	88
2-1002.00 SHRINKAGE AND SWELL FACTORS.....	88
2-1003.00 GRADING LINE THROUGH SOLID ROCK	89
2-1004.00 PRESPLITTING OF ROCK EXCAVATION.....	90
2-1005.00 CAPPING ROCK FILLS.....	90
2-1006.00 EARTHWORK BALANCES IN PLANS	90
2-1007.00 TOPSOIL REQUIREMENTS FOR EARTHWORK BALANCES.....	91
2-1008.00 ESTIMATED GRADING QUANTITIES TABULATED BLOCK	92
2-1009.00 GRADING REPORT	94
SECTION 11 – TRUCK CLIMBING LANES.....	95
2-1100.00 TRUCK CLIMBING LANE DESIGN	95
2-1100.01 LOCATION GUIDELINES	95
2-1100.02 CAPACITY ANALYSIS	96
2-1100.03 CRITICAL LENGTH OF GRADE.....	96
2-1100.04 DESIGN CRITERIA.....	104
2-1100.05 DOWNGRADES	107
2-1100.06 TRUCK SPEED PROFILE.....	107
SECTION 12 – STRUCTURAL DESIGN	112
2-1200.00 CONCRETE BOX AND SLAB TYPE CULVERTS AND BRIDGES	112
2-1200.01 TYPE DESIGNATION	112
2-1200.02 PAVED APRON FOR BOX CULVERT AND BRIDGE OUTLETS.....	112
2-1200.03 CONCRETE BOX AND SLAB TYPE CULVERTS AND BRIDGES IN SHALLOW FILLS	112
2-1200.04 STEEL BAR REINFORCEMENT (ROADWAY)	118
2-1201.00 HAUL ROADS	118
2-1201.01 HAUL ROAD DESIGN CONSIDERATIONS.....	118
2-1201.02 HAUL ROAD COMPENSATION	119
2-1201.03 HAUL ROAD TYPICAL SECTION	120
SECTION 13 - ROUNDABOUT DESIGN	121
SECTION 14 – ROAD RECONFIGURATION AND ROAD DIET	122
2-1400.00 ROAD RECONFIGURATION	122
2-1401.00 ROAD DIET	122
2-1402.00 PLANS DISTRIBUTION AND REVIEW PROCESS	123
SECTION 15 – DRIVEWAYS.....	124
2-1500.00 DRIVEWAYS	124
2-1501.00 DRIVEWAY TYPICAL SECTION AND DESIGN CRITERIA	127
2-1501.01 DRIVEWAY VERTICAL CURVES	127

**TDOT ROADWAY DESIGN GUIDELINES – PDN
CHAPTER 2 GEOMETRIC DESIGN CRITERIA**

English

Revised:

2-1501.02	DRIVEWAY HORIZONTAL CURVES	128
2-1501.03	DRIVEWAY CROSS SLOPE.....	128
2-1501.04	DRIVEWAY EDGE	128
2-1501.05	DRIVEWAY APRONS	128
2-1501.06	DRIVEWAY SIDE DRAINS	129
2-1502.00	MULTIMODAL ROADWAY DESIGN IN DRIVEWAYS.....	129
2-1503.00	GUIDELINES FOR CONSTRUCTION AND RESURFACING OF DRIVEWAYS ON HIGHWAY PROJECTS	129
2-1503.01	GENERAL.....	129
2-1503.02	RESURFACING	129
<u>2-1503.03</u>	NEW OR RECONSTRUCTION	130

INTRODUCTION

ROADWAY DESIGN GUIDELINES AND STANDARD DRAWINGS

Roadway Design Guidelines (RDG) and Standard Drawings have been created to ensure that there is consistency in TDOT projects across the state. The Roadway Design Guidelines and Standard Drawings indicate the current recognized design standards for new construction or reconstruction of existing highways and shall be utilized while giving due regard to topography, natural conditions, availability of road material, and prevailing traffic conditions.

Throughout these guidelines you will see the following terms used. To clarify the meanings intended in this guide, the following definitions apply:

- **Design Lead / Technical Lead** – Preconstruction Discipline Designer, or Consultant Discipline Designer
- **Project Manager** – assigned from Project Management division to lead Project team in delivery of project within defined scope, schedule, and budget.
- **Project Team** – Preconstruction Team consisting of a Discipline Manager, members of Roadway, Structure, Survey, Environmental, ROW, and Utilities (either TDOT staff or consulting staff), overseen by a Project Manager.
- **Concept Report** – Report developed by the Strategic Transportation Investments Division during Stage 0 of a project.

All forms mentioned throughout this chapter can be found on the [Roadway Design - TDOT Documents](#) webpage.

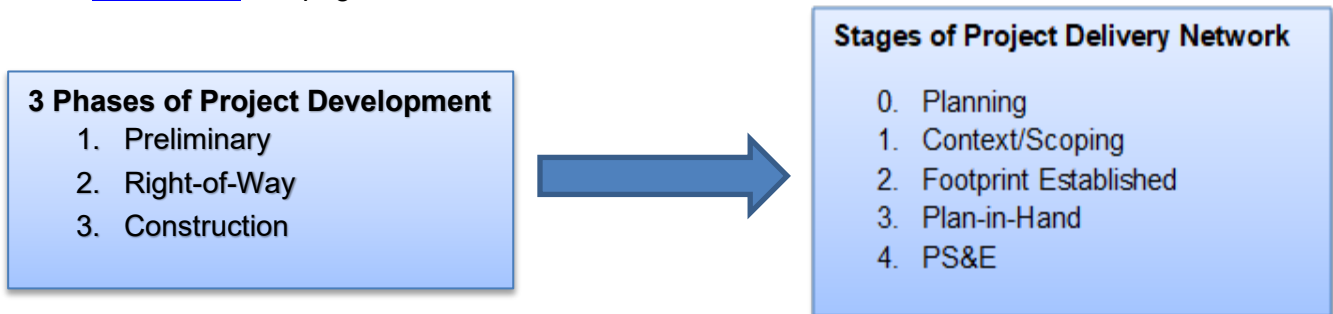

TDOT ROADWAY DESIGN GUIDELINES – PDN
CHAPTER 2 GEOMETRIC DESIGN CRITERIA

English

Revised:

This page is left blank intentionally.

SECTION 1 – CONTROLLING GEOMETRIC DESIGN CRITERIA

2-100.00 CONTROLLING CRITERIA FOR DESIGN

The following sections define both horizontal and vertical design elements including the 10 controlling criteria for design as defined by the FHWA. The 10 controlling criteria can contribute substantial importance to the operation and safety performance of any highway. A formal written design exception process should be followed if any of the following criteria cannot be met. See [Chapter 2-105.00 Design Exception Requests](#) for further guidance on the process and required form. The 10 criteria are: Horizontal Curve Radius, Superelevation Rate, Lane Width, Shoulder Width, Cross Slopes, Maximum Grade, Stopping Sight Distance, Design Speed, Vertical Clearance, and Design Loading Structural Capacity.

2-101.00 HORIZONTAL DESIGN

The Horizontal Design consists of the horizontal alignment, typical section, slope development, and roadside design. The horizontal design elements are based off of several factors including design speed, rural or urban setting, type of terrain, AADT, and superelevation. The RD11-TS series - Typical Section and Design Criteria and RD11-SE series - Superelevation Details of the Roadway Standard Drawings shall be used to determine the horizontal curve radius, superelevation, lane width, shoulder width, cross slopes, and side slopes. The proposed design speed and road type are listed in the technical report but shall always be reviewed and compared to the standard drawings to ensure the correct typical section is listed based on road type.

2-101.01 HORIZONTAL CURVE RADIUS AND SUPERELEVATION RATES

Horizontal curves provide transitions between tangent sections of roadway. Refer to RD11-SE series - Superelevation Details of the Roadway Standard Drawings and Minimum Runoff Lengths RD11-LR series of the Roadway Standard Drawings to review requirements for horizontal curve radii based on speed of the road. Designers shall refer to these tables to determine the radius required when designing horizontal alignments. Curve data is generated for each horizontal curve by CADD software programs and shall be shown on all projects. The Designer shall fill in any missing data that is not automatically generated. See *Figure 2-1, Curve Data*.

TDOT ROADWAY DESIGN GUIDELINES – PDN
CHAPTER 2 GEOMETRIC DESIGN CRITERIA

English

Revised:

I-40
CURVE SC10
PI 652+08.49
N 599,076.3989
E 1,514,512.9360
Δ 3° 33' 33" (LT)
D 1° 00' 00"
R 5,729.58
L 355.92
T 178.02
SE 0.036 FT/FT
DESIGN SPEED 70 MPH
TRANS. LENGTH 228

Figure 2-1
Curve Data

Superelevation rates and run-off for horizontal curves are also shown in the RD11-SE series – Superelevation Details of the Roadway Standard Drawings and RD11-LR series - Minimum Runoff Lengths of the Roadway Standard Drawings. For urban projects, the maximum desired superelevation rate is 0.04 ft/ft. For rural projects, the maximum desired superelevation rate is 0.08 ft/ft. If the design superelevation rates cannot be met due to existing conditions, R.O.W. limitations, or other factors, a Design Exception is required. See [Chapter 2-105.00 Design Exception Requests](#) for further guidance.

The most common type of horizontal curve is a simple circular curve; however, a spiral curve can be used to provide a gradual transition between tangent sections and circular curves. This allows vehicles to more easily transition into and out of a curve while staying within the travel lane. The superelevation tables in the RD11-LR series define when spiral curves shall be placed on projects. Spirals are recommended for curves 50 MPH or greater and superelevation of three percent or greater. In *Table 2-1, Example of Urban Superelevation Table Spiral Curves*, the first entry for a 50 MPH curve that requires a spiral curve is for a Radius of 2,290'.

**TDOT ROADWAY DESIGN GUIDELINES – PDN
CHAPTER 2 GEOMETRIC DESIGN CRITERIA**

English

Revised:

E MAX = 0.04 DESIRABLE

e d (%)	V = 20 (MPH)						V = 25 (MPH)						V = 30 (MPH)						V = 35 (MPH)						V = 40 (MPH)						V = 45 (MPH)						V = 50 (MPH)							
	R	Number of Lanes					R	Number of Lanes					R	Number of Lanes					R	Number of Lanes					R	Number of Lanes					R	Number of Lanes					R	Number of Lanes						
	MIN. (FT)	2	3	4	5	6	MIN. (FT)	2	3	4	5	6	MIN. (FT)	2	3	4	5	6	MIN. (FT)	2	3	4	5	6	MIN. (FT)	2	3	4	5	6	MIN. (FT)	2	3	4	5	6	MIN. (FT)	2	3	4	5	6		
NC	107	0	0	0	0	0	198	0	0	0	0	0	333	0	0	0	0	0	510	0	0	0	0	0	762	0	0	0	0	0	1039	0	0	0	0	0	7220	0	0	0	0	0		
2	92	32	40	49	57	65	167	34	43	51	60	69	77	86	95	104	113	122	131	140	149	158	167	176	185	194	203	212	221	230	239	248	257	266	275	284	293	302	311	320	329	338		
2.2	91	36	44	54	62	72	165	38	47	57	66	76	86	96	106	116	126	136	146	156	166	176	186	196	206	216	226	236	246	256	266	276	286	296	306	316	326	336	346	356	366	376		
2.4	91	39	48	58	68	78	164	41	51	62	72	83	94	105	116	127	138	149	160	171	182	193	204	215	226	237	248	259	270	281	292	303	314	325	336	347	358	369	380	391	402	413	424	
2.6	90	42	52	63	74	85	163	45	55	67	78	90	102	114	126	138	150	162	174	186	198	210	222	234	246	258	270	282	294	306	318	330	342	354	366	378	390	402	414	426	438	450	462	
2.8	89	45	57	68	79	91	161	48	60	72	84	96	108	120	132	144	156	168	180	192	204	216	228	240	252	264	276	288	300	312	324	336	348	360	372	384	396	408	420	432	444	456	468	
3	89	49	61	73	85	98	160	51	64	77	90	103	116	129	142	155	168	181	194	207	220	233	246	259	272	285	298	311	324	337	350	363	376	389	402	415	428	441	454	467	480	493	506	
3.2	88	52	65	78	91	104	159	55	68	82	96	110	125	139	153	167	181	195	209	223	237	251	265	279	293	307	321	335	349	363	377	391	405	419	433	447	461	475	489	503	517	531	545	
3.4	88	55	69	83	96	111	158	58	73	87	102	117	132	147	162	177	192	207	222	237	252	267	282	297	312	327	342	357	372	387	402	417	432	447	462	477	492	507	522	537	552	567	582	
3.6	87	58	73	88	102	117	157	62	77	93	108	124	140	156	172	188	204	220	236	252	268	284	300	316	332	348	364	380	396	412	428	444	460	476	492	508	524	540	556	572	588	604	620	
3.8	87	62	77	92	108	124	155	65	81	98	114	131	149	167	185	203	221	239	257	275	293	311	329	347	365	383	401	419	437	455	473	491	509	527	545	563	581	599	617	635	653	671	689	
4	86	65	81	97	114	130	154	69	85	103	120	138	156	174	192	210	228	246	264	282	300	318	336	354	372	390	408	426	444	462	480	498	516	534	552	570	588	606	624	642	660	678	696	714

METHOD 2 ← (4) → METHOD 5

**Table 2-1
Example of Urban Superelevation Table Spiral Curves**

On isolated bridge replacement projects, intersection improvements, widening of existing roadways, etc., where use of spirals would provide no real benefit and/or would be difficult to construct, spirals will not be required. It will still be necessary to provide superelevation and superelevation lengths as shown on RD11-LR series.

2-101.02 TRAVEL, THROUGH, AND TURN LANE WIDTHS

The RD11-TS Series – Typical Sections and Design Criteria Roadway Standard Drawings show the lane width requirement for travel, through, and turn lanes for each road classification. If the lane widths cannot be met due to R.O.W. restrictions, existing conditions, existing structures, etc., a Design Exception Request form shall be submitted. See [Chapter 2-105.00, Design Exception Requests](#) for further guidance. Design Exceptions are generally not needed at the beginning and ending of a project where lane widths transition down to existing conditions (example twelve feet proposed lanes transition down to existing eleven feet lanes). However, for other roads specified in the Design Exception criteria, the designer shall refer to the typical section standards and evaluate all available information on the road to ensure the best, most economical lane width is proposed. If the Designer has questions or concerns due to the lane width, they should discuss it immediately with the Design Manager and Design Team as well as the Strategic Transportation Investment Division (STID) who furnished the technical report.

2-101.03 SHOULDER WIDTHS

Widths for outside and inside (if applicable) shoulders are defined in each of the RD11-TS Series – Typical Sections and Design Criteria Roadway Standard Drawings based on road classification. If the shoulder width needs to be reduced due to R.O.W. restrictions, existing conditions, existing structures, etc., a Design Exception Request form shall be submitted. See [Chapter 2-105.00, Design Exception Requests](#), for further guidance.

TDOT ROADWAY DESIGN GUIDELINES – PDN
CHAPTER 2 GEOMETRIC DESIGN CRITERIA

English

Revised:

For lower volume roads, the outside shoulder may be graded only and not paved. For most rural designs, the shoulder will have a greater portion that is paved with a 2' portion that is not. (12' shoulder will have 10' paved; 6' shoulder will have 4' paved; shoulders less than 6' should be fully paved). It is sometimes economical to pave out the additional 2' and this should be discussed at the Functional Plans field review.

When calculating drainage spread, the inside and/or outside shoulder may be used to carry a portion or all of the water. Often, initial drainage calculations include the entire shoulder width plus one-half of a travel lane for spread. On projects where the existing shoulders are used for spread on a closed drainage system, the Designer shall ensure that the reduced shoulder width can still accommodate the flow without increasing the spread more than the amount allowed into the travel lane.

2-101.04 CROSS SLOPES

The cross slopes of travel lanes and shoulders are defined in each of the RD11-TS Series – Typical Sections and Design Criteria Roadway Standard Drawings based on road classification. If the cross slope does not match the standard drawing, a Design Exception Request and Justification form shall be submitted. See [Chapter 2-105.00, Design Exception Requests](#) for further guidance. The cross slope of a road is normal crown (-0.02 ft/ft) unless it is in a superelevated section. Shoulder cross slopes are usually -0.04 ft/ft. The slopes of the shoulder and roadway pavement shall not exceed an algebraic difference of 0.07 ft/ft.

Designers shall refer to the appropriate RD11-TS Series – Typical Sections and Design Criteria Roadway Standard Drawings to determine what the change in cross slope should be for more than two travel lanes in the same direction. The Designer shall evaluate the drainage for all widening and new alignment projects to ensure the cross slope will drain the road and not cause ponding issues. This is especially critical on interstate widening projects where drainage occurs along a median barrier wall and the existing inside shoulder width may be reduced to accommodate additional lanes.

2-102.00 VERTICAL DESIGN

The Vertical Design consists of the vertical alignment and components of grade, stopping sight distance, passing sight distance, and vertical clearance. The vertical alignment and how it coincides with the horizontal alignment is reflected in the RD11-TS Series-Typical Sections and Design Criteria Roadway Standard Drawings. These standards shall be used to determine maximum grades for specific design speeds and terrain types, minimum stopping sight distance, and minimum passing sight distance.

There are often times when some of the vertical design criteria cannot be met for a portion of the road on a project. A Design Exception shall be requested for the following vertical

TDOT ROADWAY DESIGN GUIDELINES – PDN
CHAPTER 2 GEOMETRIC DESIGN CRITERIA

English

Revised:

components: maximum grade, stopping sight distance, or vertical clearance. See [Chapter 2-105.00, Design Exception Requests](#) for further guidance.

2-102.01 VERTICAL GRADES

The RD11-TS Series - Typical Sections and Design Criteria Roadway Standard Drawings list the maximum vertical grade based on design speeds and terrain types. If the maximum grade is exceeded, a Design Exception is required. See [Chapter 2-105.00, Design Exception Requests](#) for further guidance. However, if the grades exceed the maximum recommendations where the Designer is matching existing vertical grade at the beginning and end of the project, a Design Exception is not needed. If there is a question of whether or not a Design Exception is needed, they shall contact the Engineering Production Support Division at TDOT.EngineeringProductionSupport@tn.gov.

The Designer shall consider constructability of the road, side roads, and private drives when designing the vertical grade. Large cuts and fills are very difficult to construct. If this is unavoidable, the Designer shall discuss traffic control options at the Functional Design field review.

2-102.02 STOPPING SIGHT DISTANCE

Stopping Sight Distance is the distance that a motorist needs to be able to stop before colliding into something in the road such as another vehicle, pedestrian, debris, etc. Stopping sight distance requirements are incorporated into the RD11-TS Series – Typical Sections and Design Criteria Roadway Standard Drawings. If the criteria for K-values for Stopping Sight Distance are not met, a Design Exception is required. See [Chapter 2-105.00, Design Exception Requests](#) for further guidance.

2-102.03 STOPPING SIGHT DISTANCE ON HORIZONTAL AND VERTICAL INTERSECTIONS

Designers shall evaluate stopping sight distance and understand the correlation between horizontal and vertical components. Stopping Sight Distance shall be determined for both horizontal and vertical curves at intersections. The Designer shall ensure that intersection sight distance is provided in addition to adequate stopping sight distance at all intersections, railroad crossings without train activated warning devices, and commercial drives. The Designer can calculate the line of sight in these cases. Refer to the RD11-SD Series – Intersection Sight Distance Roadway Standard Drawings- for line of sight calculations and tables.

2-102.04 STOPPING SIGHT DISTANCE ON HORIZONTAL AND VERTICAL CURVES

Sight distance should be determined for both horizontal and vertical curves at intersections. *Figure 2-2, Line of Sight for Stopping Sight Distance for Horizontal Curve*, depicts

TDOT ROADWAY DESIGN GUIDELINES – PDN
CHAPTER 2 GEOMETRIC DESIGN CRITERIA

English

Revised:

a situation where the driver is traveling around a curve and the line of sight needed to ensure the other car is visible. If vegetation or other obstacles were in the designated clear zone area, the motorists would not be able to see the car. Designers shall always evaluate the line of sight for areas such as this and where guardrail, median barrier, retaining walls, vegetation, utility poles, and other roadside elements may cause a sight distance issue which in turn causes a stopping sight distance problem.

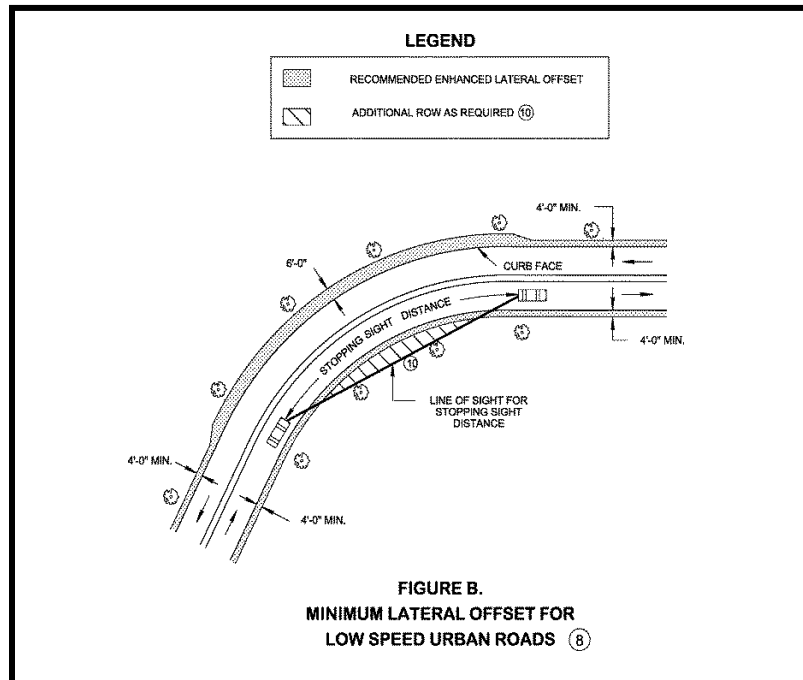

Figure 2-2
Line of Sight for Stopping Sight Distance for Horizontal Curve

Figure 2-3, *Line of Sight for Stopping Sight Distance for Vertical Curve*, depicts a situation where the driver is traveling over a hill and the road hazard is on the downgrade. Designers shall always evaluate the stopping sight distance on vertical curves where factors such as signalized intersections, side roads, driveway entrances, etc. could cause sight distance issues.

TDOT ROADWAY DESIGN GUIDELINES – PDN
CHAPTER 2 GEOMETRIC DESIGN CRITERIA

English

Revised:

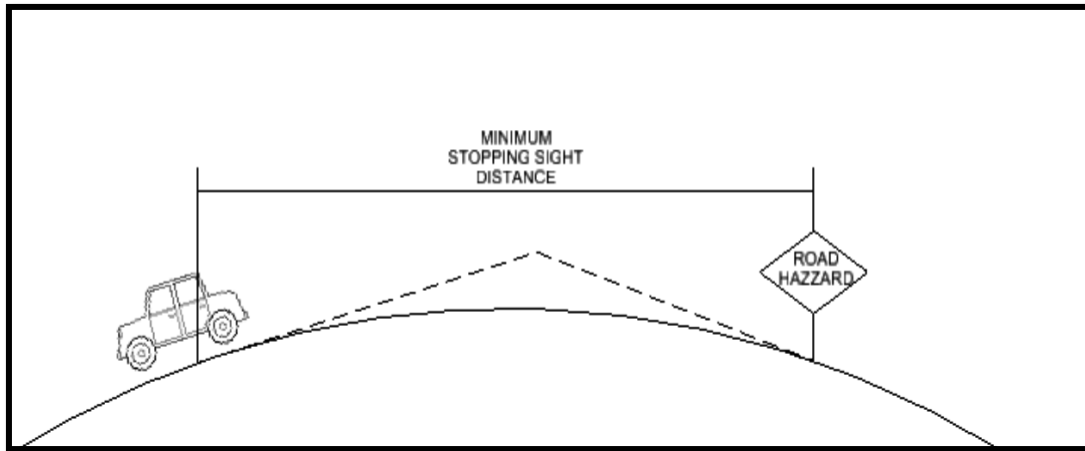

Figure 2-3
Line of Sight for Stopping Sight Distance for Vertical Curve

When designing traffic control plans, stopping sight distance should also be evaluated. When possible, lane drops should be avoided on horizontal and/or vertical curves so that drivers are in a tangent section during the lane drop. Also, designers should ensure that signing is adequate when there are existing stopping sight distance issues or when the construction may be impairing stopping sight distance.

2-102.05 VERTICAL CLEARANCES FOR BRIDGES

The minimum vertical clearance for all structures on all systems shall not be less than 16 feet over the entire roadway width, including the usable width of shoulder. The vertical clearance to sign trusses and pedestrian overpasses shall be 17 feet because of their reduced resistance to impacts. The vertical clearance from the deck to the cross bracing on through truss structures shall also be a minimum of 17 feet. The minimum vertical clearance for railroad crossings from the structure to the top of the rails shall be 23 feet. An allowance of 6 inches shall be added to all vertical clearances to accommodate future resurfacing.

If the length for Stopping Sight Distance is not met, a Design Exception is required. See [Chapter 2-105.00 Design Exception Requests](#) for further guidance. On crossings of low volume roadways where the cost of providing 16 feet of clearance might be considered unreasonable and may justify an exception, the Design Manager and Structures Division personnel shall complete a joint cost analysis justifying a reduction in vertical clearance. This cost analysis shall be submitted to the Director of the Structures Division for approval.

TDOT ROADWAY DESIGN GUIDELINES – PDN
CHAPTER 2 GEOMETRIC DESIGN CRITERIA

English

Revised:

2-103.00 DESIGN SPEED

The design speed is different from the other controlling criteria in that it is a design control, rather than a specific design element. In other words, the selected design speed establishes the range of design values for many of the other geometric elements of the roadway. Generally, Design Exceptions are requested when the design speed cannot be maintained for the entire project. An example would be that a horizontal or vertical curve could not be designed to meet the proposed design speed. When this occurs, a Design Exception shall be requested for that curve. The project shall be signed with the appropriate advisory speed at locations on the plans where this occurs.

2-104.00 DESIGN LOADING STRUCTURAL CAPACITY

Safe load-carrying capacity for all State unrestricted legal loads or routine permit loads and, in the case of bridges and tunnels on the Interstate, all Federal legal loads is a controlling criteria and shall be evaluated. The Structures Division verifies the loading structural capacity of structures on the roadway. If the proposed design loading structural capacity is not met, a Design Exception shall be requested.

2-105.00 DESIGN EXCEPTION REQUESTS

Despite the range of flexibility that exists with respect to the controlling elements of design, there are situations in which the accepted criteria are not applicable to the project circumstances or cannot reasonably be met. For such instances, when it is appropriate, the [design exception](#) process allows for the use of criteria other than the accepted values. Design exceptions can be viewed as opportunities to add practicality or value to the design and should not necessarily be considered as violation of policy. See PDN 2RD1 for more information.

The design exception process requires formal approval for exceptions relating to the following 10 controlling criteria of design:

Type I Exception to Controlling Criteria

- Design Speed
- Design Loading Structural Capacity

For exceptions based on Type I Criteria, all roadways on the **NHS** may require FHWA's review. The Roadway Design Division Director provides final approval. Exceptions to Type I criteria are rare and additional information shall be provided.

TDOT ROADWAY DESIGN GUIDELINES – PDN
CHAPTER 2 GEOMETRIC DESIGN CRITERIA

English

Revised:

Type II Exception to Controlling Criteria

- Lane Width
- Horizontal Curve Radius
- Stopping Sight Distance
- Shoulder Width
- Cross Slopes
- Vertical Clearance
- Superelevation Rate
- Maximum Grade

For exceptions based on Type II Criteria, all roadways on the **NHS** with design speeds \geq 50 mph may require FHWA's review. The Roadway Design Division Director provides final approval.

All other roadways (non-NHS) exceptions to controlling criteria do not require FHWA's review; the Roadway Design Division Director provides final approval.

Projects designated as Limited Scope do not require a design exception.

Note:

Roadways on the Appalachian Development Highway System, or FHWA Projects of Division Interest (PODI) may require FHWA's review for design exceptions regardless of the controlling criteria.

Design exception requests for projects shall be submitted to the Regional Director of Project Development using the Design Exception Form. Once reviewed and recommended for approval, the Regional Director of Project Development shall forward the design exception request form to the Engineering Division Director (or Designee), who will either provide final approval or forward to FHWA for final approval, as appropriate.

Approved design exceptions **shall** be noted, with approval date, in the lower right corner of the title sheet as well as on the cover sheet for the Functional Design.

All applicable material from the following list shall be addressed in narrative form on the Design Exception Request Form by the Designer. For locally developed projects, the highest local official responsible for the project is responsible for this task.

1. Accident experience or data.
2. The effect of the variance from the design standard on safety and operation of the facility.
3. Any safety mitigation measures considered and provided to minimize the effect of the reduced design.
4. The compatibility of the design and operation with adjacent sections.
5. The comparative cost of the full standard versus the reduced design being proposed.
6. The long-term effect of the reduced design as compared to the full standard.

TDOT ROADWAY DESIGN GUIDELINES – PDN
CHAPTER 2 GEOMETRIC DESIGN CRITERIA

English

Revised:

7. The difficulty in obtaining the full standard such as right-of-way restriction, delays, environmental impacts, etc.
8. Any capacity reductions or operational problems caused by the proposed exception.
9. Level of service for full standards versus the reduced design.
10. The cumulative effect of more than one standard that is being reduced.
11. The possibility of improving or correcting the reduced design feature in the future

SECTION 2 – NON-CONTROLLING GEOMETRIC DESIGN CRITERIA

2-200.00 NON-CONTROLLING GEOMETRIC DESIGN CRITERIA

In addition to the 10 controlling criteria designated by FHWA, there are other criteria that are critical to the geometric design. Any deviation from the standards for these design elements will require a [Design Waiver](#) as opposed to a Design Exception. See PDN 2RD1 for more information.

2-200.01 PASSING SIGHT DISTANCE

Passing sight distance requirements are incorporated into the RD11-TS Series – Typical Sections and Design Criteria Roadway Standard Drawings. Sufficient passing sight distance is a major factor when designing a two-lane road. The Designer shall ensure both the horizontal and vertical design is sufficient to provide passing zones. The motorist needs vertical sight distance as well as horizontal passing zone length. Refer to *A Policy on Geometric Design of Highways and Streets*, AASHTO, 2011, Chapter 3.

2-200.02 VERTICAL CURVES

A vertical curve provides a transition between two different roadway profile grades, allowing the vehicle to negotiate the elevation rate change at a gradual rate rather than a sharp angle (see *Figure 2-4, Vertical Curves*). The design of the curve is dependent on the intended design speed for the roadway, as well as drainage, slope acceptable rate of change, and friction. Refer to *A Policy on Geometric Design of Highways and Streets*, AASHTO, 2011, Chapter 3. Proper design of vertical curves helps minimize and balance cut and fill; provides sufficient sight distance; and maintains adequate drainage. See the Roadway Design Typical Section and Design Criteria standard drawings for maximum grades, minimum stopping sight distances, design stopping sight distances, and minimum “K” values for crest, sag and passing sight distance for crest curves.

TDOT ROADWAY DESIGN GUIDELINES – PDN
CHAPTER 2 GEOMETRIC DESIGN CRITERIA

English

Revised:

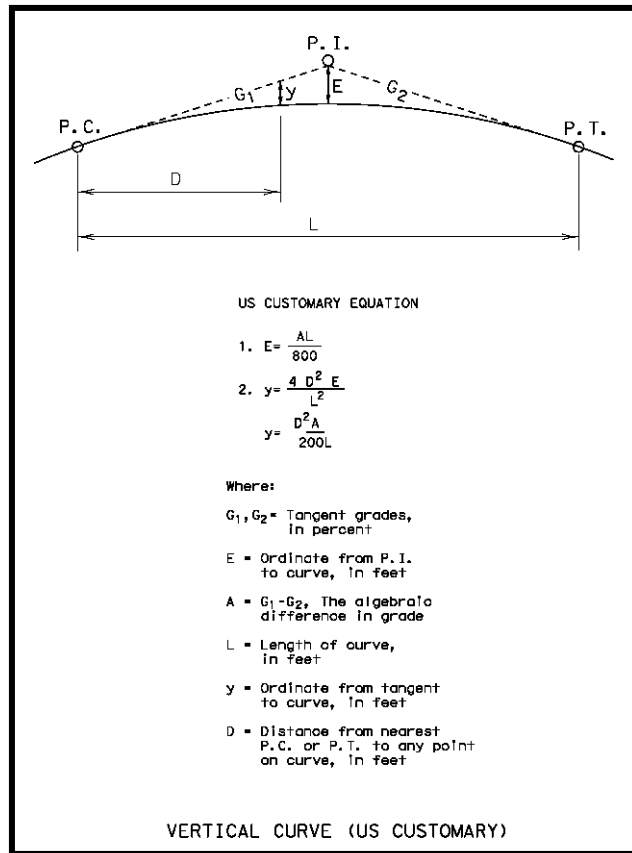

Figure 2-4
Vertical Curves

2-200.03 ROADSIDE SLOPE DEVELOPMENT

The soils and geology report is required as outlined in the Project Delivery Network 2GT1. Information from this report will provide the Designer with alternate slopes that may be needed that differ from the Standard Drawings and/or information on other measures that may be needed for slope stabilization, such as the addition of a rock pad, rock buttress, etc.

Roadside slopes are generally classified as a recoverable, traversable, non-traversable or critical slope.

- Traversable slopes consist of a slope that is 3:1 or flatter and free of obstructions in the clear zone.
- Recoverable slopes consist of a slope that is 4:1 or flatter and free of obstructions in the clear zone.

TDOT ROADWAY DESIGN GUIDELINES – PDN
CHAPTER 2 GEOMETRIC DESIGN CRITERIA

English

Revised:

- Non-traversable slopes are either steeper than 3:1 or have obstructions in the clear zone.
- Critical slopes consist of a slope that is non-traversable and shall be protected by guardrail, retaining wall, barrier rail, cable barrier, etc.

2-200.04 CLEAR ZONE

Clear zone is the unobstructed traversable portion of the roadside that allows a driver who has lost control of their vehicle to re-gain control and stop safely. Clear zone criteria are defined in the S-CZ Series – Clear Zone and Safety Plans Roadway Standard Drawings. If at all possible, nothing shall be located within this area. However, the standard drawings take the Designer through the steps to determine what to do to a hazard that is located in the clear zone. Options are removal, relocation, making the obstacle breakaway, shielding with barrier, or delineating the object. Designers often miss obvious roadside hazards such as endwalls, interstate sign poles located in medians, etc. Rigid roadside features such as abutments or bridge parapets shall be placed such that a minimum 24' clear path (both travel lanes + shoulder) is provided for large farm equipment on rural roadways. Refer to the *Roadside Design Guide*, AASHTO, current version, for further information for clear zone areas.

CLEAR ZONES IN URBAN AREAS BEHIND CURB AND GUTTERS

In rural areas, the typical sections for clear zones are easily defined based on the typical sections and distance between the edge of pavement line and ditch. Clear zones in urban areas are usually harder to determine because of the numerous factors such as whether a grass strip is located between the back of curb and the sidewalk or if the sidewalk is a larger shared-use path, etc. The S-CZ Series (Clear Zone and Safety Plans) and MM-SW-1 Roadway Standard Drawings clearly define what the clear zone is in several situations. The Designer shall ensure that ADA accessibility requirements are met if a pole must be placed in a sidewalk area because there are no other options. In this case, there has to be a minimum of four feet (4') clearance from the hazard to the edge of the sidewalk (See MM-SW-1 for more information). This shall be discussed at the Functional Design field review with all utilities that are located within the project as well as the Traffic Operations Division if signals and/or lighting are proposed on the project.

CLEAR ZONES ON CURVED ALIGNMENTS

Designers shall evaluate the clear zone on curves. In Chapter 3 of the AASHTO *Roadside Design Guide*, a formula is given for an increase in clear zone on the outside of curves. The clear zone on a curved alignment is determined by increasing the value obtained from the *Roadside Design Guide* method for a tangent section of highway. The tangent section clear zone is increased by a curve correction factor, which is based on the degree of curvature and the design speed. No obstacles shall be located within the line of sight around the curve. It may be that additional R.O.W. is purchased to ensure that this criterion is met.

**TDOT ROADWAY DESIGN GUIDELINES – PDN
CHAPTER 2 GEOMETRIC DESIGN CRITERIA**

English

Revised:

TABLE A. CLEAR ZONE DISTANCE (Lc) (FEET)							
DESIGN SPEED	DESIGN ADT	FORESLOPES (H:V)			BACKSLOPES (H:V)		
		6:1 OR FLATTER	5:1 TO 4:1	3:1	6:1 OR FLATTER	5:1 TO 4:1	3:1
40 MPH OR LESS	UNDER 750 (7)	7 - 10	7 - 10	(4)	7 - 10	7 - 10	7 - 10
	750 - 1500	10 - 12	12 - 14	(4)	12 - 14	12 - 14	12 - 14
	1500 - 6000	12 - 14	14 - 16	(4)	14 - 16	14 - 16	14 - 16
	OVER 6000	14 - 16	16 - 18	(4)	16 - 18	16 - 18	16 - 18
45-50 MPH	UNDER 750 (7)	10 - 12	12 - 14	(4)	10 - 12	8 - 10	8 - 10
	750 - 1500	14 - 16	16 - 20	(4)	14 - 16	12 - 14	10 - 12
	1500 - 6000	16 - 18	20 - 26	(4)	16 - 18	14 - 16	12 - 14
	OVER 6000	20 - 22	24 - 28	(4)	20 - 22	18 - 20	14 - 16
55 MPH	UNDER 750 (7)	12 - 14	14 - 18	(4)	10 - 12	10 - 12	8 - 10
	750 - 1500	16 - 18	20 - 24	(4)	16 - 18	14 - 16	10 - 12
	1500 - 6000	20 - 22	24 - 30	(4)	20 - 22	16 - 18	14 - 16
	OVER 6000	22 - 24	26 - 32 (3)	(4)	22 - 24	20 - 22	16 - 18
60 MPH	UNDER 750 (7)	16 - 18	(9)	(9)	14 - 16	12 - 14	10 - 12
	750 - 1500	20 - 24	(9)	(9)	20 - 22	16 - 18	12 - 14
	1500 - 6000	26 - 30	(9)	(9)	24 - 26	18 - 22	14 - 18
	OVER 6000	30 - 32 (3)	(9)	(9)	26 - 28	24 - 26	20 - 22
65-70 MPH	UNDER 750 (7)	18 - 20	(9)	(9)	14 - 16	14 - 16	10 - 12
	750 - 1500	24 - 26	(9)	(9)	20 - 22	18 - 20	12 - 16
	1500 - 6000	28 - 32 (3)	(9)	(9)	26 - 28	22 - 24	16 - 20
	OVER 6000	30 - 34 (3)	(9)	(9)	28 - 30	26 - 30	22 - 24

ADAPTED FROM TABLE 3.1 OF THE "ROADSIDE DESIGN GUIDE," AASHTO, 2011.

**Figure 2-5
Clear Zone Distance (Lc)**

The Designer must remember that the clear zone values (Lc), *Figure 2-5, Clear Zone Distance (Lc)*, are based on a constant side slope throughout the clear zone distance. In situations where the side slope changes within the calculated clear zone, the clear zone must be recalculated based on a weighted average of the side slopes.

2-200.05 DESIGN VEHICLE

Designers should consider the largest design vehicle that is likely to frequently use the road to determine the design vehicle. For urban areas, public transportation vehicles (CITY-BUS) shall be the design vehicle. For rural and suburban areas, a large school bus (S-BUS40) shall be the design vehicle. If the traffic report indicates 2% or more truck traffic, then a semi-truck (WB-67) size shall be evaluated for both rural and urban areas. Design vehicles should be carefully considered anywhere they are expected to make a turning movement through an intersection. For more information on design vehicles, see the AASHTO Green Book and Roadway Standard RD11-SD series. If the project design is unable to meet these design vehicles, a design waiver form should be submitted.

TDOT ROADWAY DESIGN GUIDELINES – PDN
CHAPTER 2 GEOMETRIC DESIGN CRITERIA

English

Revised:

2-200.06 MULTIMODAL FACILITIES

The Designer shall refer to RDG Chapter 3, Multimodal Design for guidance on bicycle lanes. The MM-TS Series – Typical Sections and Design Criteria of the Roadway Standard Drawings provides width requirements for bicycle and pedestrian facilities for several applications.

2-201.00 DESIGN WAIVER REQUESTS

A Design Waiver is a variance not based on the 10 controlling design criteria. It is any variance from the TDOT Standard Drawings. These requests include, but are not limited to, clear zone width, passing sight distance, vertical curves, and multimodal features. A Design Waiver Request Form shall be submitted for approval by the Regional Project Development Director and then approved by the Engineering Division Director (or Designee). See PDN 2RD1 for more information.

Approved design waivers **shall** be noted, with approval date, in the lower right corner of the title sheet as well as on the cover sheet for the Functional Design and Plan-in-Hand checklist. Justification shall be provided on the Design Waiver Request Form.

SECTION 3 – ROADSIDE DESIGN CRITERIA

2-300.00 ROADSIDE DESIGN CRITERIA

The roadside is defined as the area beyond the traveled way. The Roadside Safety Design focuses on the placement and selection of roadside safety features with the intention of minimizing the consequences of a motorist inadvertently leaving the roadway. Roadside safety technology is a rapidly changing, evolving field. As performance experience is gained and research programs reveal new and improved practices, roadside design criteria and safety policies are being updated as well.

While it may not be practical or feasible to apply all new technology to existing roadways, Designers should use this section to evaluate and reduce the severity of impacts during reconstruction projects on existing alignment. Refer to the Maintenance Division's [Pavement Resurfacing Program Standard Operating Guidelines](#) for low cost safety improvements that could be applied during the development of resurfacing plans.

This chapter discusses the development and evaluation of the forgiving roadside concept and its application to roadside design and clear zones applicable to new construction and major reconstruction projects. For more information refer to the AASHTO Roadside Design Guide and FHWA's Office of Safety. The designers shall complete the project-specific design criteria document as detailed in PDN Section 1RD1. At locations where the following roadside design criteria could not be met, Designers shall complete a [Design Exception](#) or a [Design Waiver](#) form for roadway cross sectional elements to evaluate safety in design.

2-301.00 CLEAR ZONE CONCEPT

As initially depicted in the Line and Grade package and finalized in the Functional Design Plans, a clear zone is the unobstructed, traversable area provided beyond the edge of the through traveled way for the recovery of errant vehicles. The clear zone may consist of shoulders, bike lanes, auxiliary lanes (unless functioning as a through lane), a recoverable slope, a non-recoverable slope, and/or a clear run-out area. Obstacles located within this clear zone distance should be removed, relocated, redesigned to be crashworthy, or shielded by traffic barriers or crash cushions.

Roadway Standard Drawing S-CZ-1 provides a general approximation of clear zone distances. The tabulated data shown in the drawing are based on limited empirical research extrapolated to provide suggested clear zone distances to address for a wide range of conditions. Designers should keep in mind site-specific conditions, design speeds, rural versus urban locations, and practicality when reviewing clear zones. It is important to remember the clear zone distance with horizontal curves are always larger (10% to 50%) than tangent sections. The distances obtained from Roadway Standard Drawing S-CZ-1 should suggest only the

TDOT ROADWAY DESIGN GUIDELINES – PDN
CHAPTER 2 GEOMETRIC DESIGN CRITERIA

English

Revised:

approximate center of a range to be considered and not a precise distance to be held as absolute. For roadways with low traffic volumes (ADT<2000), it may not be practical to apply even the minimum values found in Roadway Standard Drawing S-CZ-1.

2-302.00 ROADSIDE BARRIERS

Roadside barriers are used to protect the traveling public from an unavoidable and unmovable object, body of water, non-traversable slopes, and to prevent lane departures into oncoming traffic. Roadside barriers should only be placed in areas where a roadside hazard exists that cannot be removed and the potential harm from an impact with the barrier is less serious than impacting an object or the potential of overturning resulting from a non-traversable steep slope. The warrants below are meant as a guideline for Designers to make the determination initially determined in the Functional Design Plans and detailed fully in the Plan-in-Hand plans.

When barriers are indicated by warrant, Designers should first consider the following in the order listed:

1. Remove the obstacle. (Is the obstacle necessary? If not remove the obstacle.)
2. Relocate the obstacle to a point where it is less likely to be struck. (If the obstacle is necessary, can it be moved outside of the clear zone?)
3. Redesign the obstacle to be safely traversed. (Such as flattening a steep 2:1 slope to flatter than 3:1)
4. Reduce impact severity by using an appropriate breakaway device. (Typically applies to signs and some poles)

Based on site conditions, Designers should also consider the use of a rumble strip/stripe, to delineate the obstacle, provide advanced warning signs, and in some cases reduce the design speed (or posted speed for reconstruction projects).

The following sections give guidance on warrants, length of need, and choosing the appropriate barrier system.

2-302.01 BARRIER WARRANT 1: AT BRIDGES OR CULVERTS

Barriers are warranted anytime the road crosses a bridge, box culvert or slab bridge. Most structures will be designed with a specified concrete bridge rail by the Structures Division. A minimum length of bridge transition section with proper end terminal must be provided at bridge ends. Typical Length of Need (LON) distance will be greater so the designer should determine the minimum LON required for each approach. Due to existing considerations, providing the desired LON may be limited during reconstruction and rehabilitation projects or routine maintenance activities. The Designer should use sound engineering judgement during the roadside design of such projects. See [Chapter 2-302.06, Barrier Length of Need](#) for more information.

TDOT ROADWAY DESIGN GUIDELINES – PDN
CHAPTER 2 GEOMETRIC DESIGN CRITERIA

English

Revised:

For installation details when Warrant 1 is met, see Roadway Standard Drawings - Safety Plan series:

- **S-PL-1** SAFETY PLAN AT ROADSIDE HAZARDS
- **S-PL-3** SAFETY PLAN MINIMUM INSTALLATION AT BRIDGE ENDS
- **S-PL-4** SAFETY PLAN FOR BRIDGE PIERS IN CLEAR ZONE
- **S-PL-5** SAFETY PLAN FOR BRIDGE ENDS IN MEDIANS

In some cases, box culverts or slab bridges may use guardrail instead of bridge parapet rail. The amount of fill over the bridge will determine how the guardrail will be installed. See [Chapter 2-303.01, Guardrail Special Designs](#) and Roadway Standard Drawing S-GRS-2 for more information.

During the development of reconstruction projects on existing alignment, at locations where a bridge transition with tangential guardrail end terminal could not be installed due to intersection side road or a driveway, the Designer should evaluate the best practices to reduce the crash severity. Some design alternatives include: maintaining the same hardware type to eliminate transition section; installing a curve guardrail (Roadway Standard Drawing S-GRS-7) rather than a tangential guardrail terminal; or installing a crash cushion, which will reduce the impact severity (but may not satisfy the length of need). These will offer significant safety benefits at locations with extreme site limitations. Bridges located within a horizontal curve on high speed ($V > 45$ mph) rural highways may need further evaluation. Providing additional lateral offset (wider outside shoulder) will provide a safety benefit at locations with road departure crash history.

2-302.02 BARRIER WARRANT 2: NON-TRAVERSABLE SLOPES

One of the controlling criteria of geometric design is side slope (foreslope) development. Providing traversable foreslopes within the clear zone to reduce crash severity is also a roadside safety design criteria. A typical side slope design should follow the Roadway Standard Drawing RD11-TS- Series showing traversable side slope rates based on functional classification, speed, and ADT. In addition, the Roadway Standard Drawing RD11-S-11 provides traversable rounding details at slope break and Roadway Standard Drawing RD11-S-11A provides typical sections of traversable ditch designs. Refer to *Figure 2-6, Preferred Traversable “V” Ditch Cross Section Configurations* for preferred ditch configurations.

TDOT ROADWAY DESIGN GUIDELINES – PDN
CHAPTER 2 GEOMETRIC DESIGN CRITERIA

English

Revised:

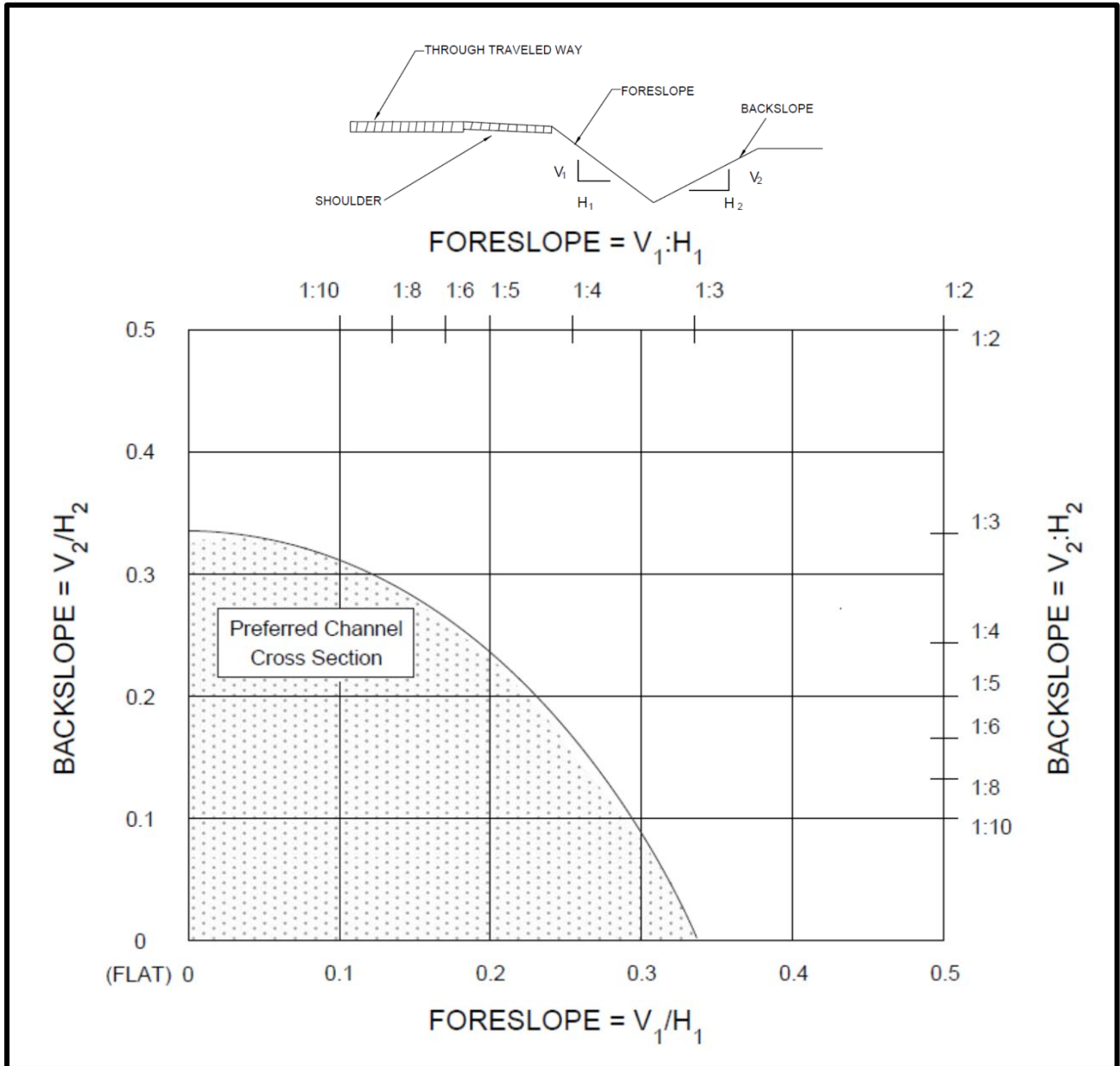

Figure 2-6
Preferred Traversable “V” Ditch Cross Section Configurations
(Ref. AASHTO Roadside Design Guidelines 4th Edition)

TDOT ROADWAY DESIGN GUIDELINES – PDN
CHAPTER 2 GEOMETRIC DESIGN CRITERIA

English

Revised:

Fill section slopes (foreslopes) located inside the clear zone are categorized as:

- Recoverable slopes: fill slopes between 6:1 to 4:1, an errant vehicle could return to roadway,
- Non-recoverable slopes: fill slopes between 4:1 to 3:1, an errant vehicle usually maintains stability reaching the toe of the fill, therefore, additional 10' of clear landing area is desired within the ROW - See AASHTO Roadside Design Guide, 4th edition, Section 3.3.2 Non-Recoverable Foreslopes.
- Critical slopes: fill slopes steeper than 3:1.

Barriers are warranted if the combination of non-recoverable or critical fill slopes and the fill section height combine to create a hazard for an errant vehicle departing the travel lane. See the below *Figure 2-7, Comparative Barrier Consideration for Embankments* for warrant criteria.

In addition to the main roadway foreslope, there are other intersecting slopes of the roadway, driveway, or median crossovers located inside the clear zone called Transverse Slopes. Although the exposure to transverse slopes is less than foreslopes or backslopes, they generally are more critical to errant vehicles because run-off-the-road vehicles typically strike them head-on. Transverse slopes 6:1 or flatter are suggested for high speed facilities located inside the clear zone. Designer should use D-SEW-1A parallel pipe endwalls inside the clear zone matching 6:1 fill slope. Pipes located under median crossovers will use D-SEW-12D pipe endwall at 12:1 slope.

TDOT ROADWAY DESIGN GUIDELINES – PDN
CHAPTER 2 GEOMETRIC DESIGN CRITERIA

English

Revised:

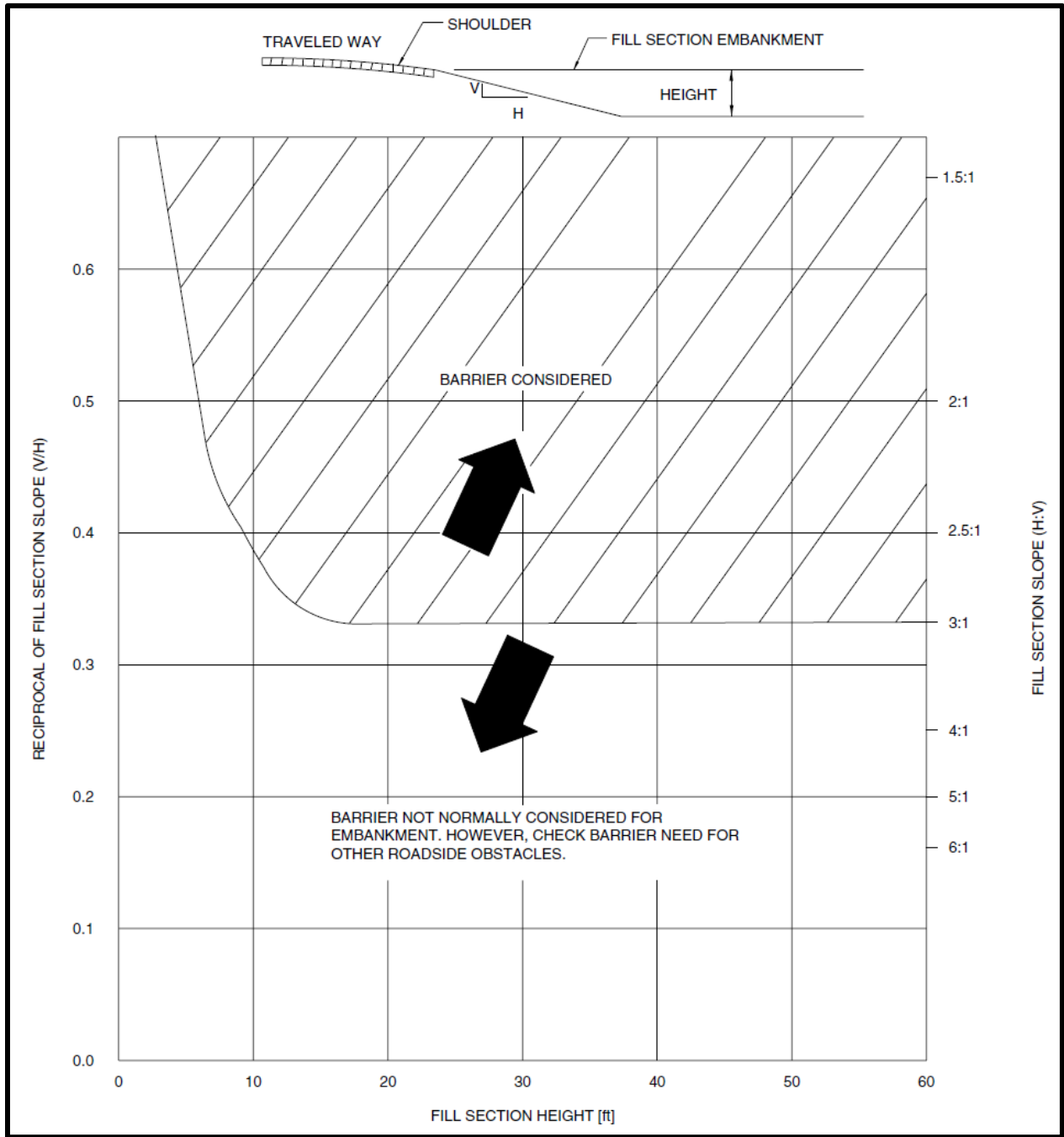

Figure 2-7
Comparative Barrier Consideration for Embankments

TDOT ROADWAY DESIGN GUIDELINES – PDN
CHAPTER 2 GEOMETRIC DESIGN CRITERIA

English

Revised:

2-302.03 BARRIER WARRANT 3: ROADSIDE OBSTACLES

Barriers are warranted on high speed roadways anytime an obstacle is found inside the clear zone area (as defined on Roadway Standard Drawing S-CZ-1) based on traffic volumes, speeds, and slopes. Designers should consider the context of the roadway location since the implementation of S-CZ-1 may not be feasible in urban locations.

For installation details of barriers when Warrant 3 is met, see Roadway Safety Plan Standard Drawing S-PL Series. Typical obstacles are listed below, though other obstacles not on the list may also warrant a barrier if determined by engineering judgment.

Typical Roadside Obstacles Warranting Barriers

- Critical fill slopes (less than 3:1)
- Steep transverse slopes (fill slope of intersecting side road)
- Trees
- Poles
- Bridge Abutments and Piers
- Retaining Walls
- Streams
- Traffic Signal Poles
- Lighting Structures
- Overhead Sign Structures
- Utility Structures
- Pipe Headwalls (Type A, B, or Straight)

In general, the following roadside objects are not considered hazards. These objects may be installed in the clear zone (if noted conditions are met) without the need for shielding.

Typical Objects Not Warranting Barriers

- Objects utilizing breakaway supports approved by the Department such as small or large signs posts, light poles.
- Relatively smooth vertical backslopes (such as rock cuts) generally do not require protection as impacting a barrier is unlikely to provide any benefit to the occupant of the vehicle as opposed to striking the vertical backslope. Delineation of the backslope is recommended on the outside of a curve.
- Right-of-way Fences
- Cross drains utilizing Roadway Standard Drawing D-PE Series “U” endwalls or side drains (parallel drains) with D-SEW endwalls. These endwalls are designed to be traversable and will allow a vehicle to safely pass over.
- Small trees (less than 4” in diameter)

TDOT ROADWAY DESIGN GUIDELINES – PDN
CHAPTER 2 GEOMETRIC DESIGN CRITERIA

English

Revised:

2-302.04 BARRIER WARRANT 4: FREEWAY MEDIAN DEPARTURES

On full or semi-full access-controlled highways or freeways where the opposing lanes of traffic are separated by an at-grade (paved) median, a barrier should be considered at locations where proper clear zone width cannot be provided. In cases when the freeway is separated by a depressed median, the fill slopes of the median should provide traversable clear zone distance in accordance with Roadway Standard Drawing S-CZ-1 for an errant vehicle to recover. If one or more of the below conditions exist, barriers are warranted for the median.

- This warrant is independent of, and superseded by, warrants 1 through 3. In cases where a bridge end, obstacle, or steep slope is present in the median, placing barriers for those conditions take precedence.
- For installation of barriers when Warrant 4 is met, double sided median guardrail, cable barrier, or concrete median barrier with crash cushions based on the site conditions may be used. See Roadway Standard Drawings: S-PL-6 and S-PL-6A.

2-302.05 EXCEPTIONS TO BARRIER WARRANTS

In certain cases, barriers should not be placed because doing so would be undesirable for the level of access provided by the roadway, be infeasible due to lack of sufficient space, or cause greater safety hazards than the hazard being shielded. In general, the following conditions generally do not warrant barrier protection.

Urban Context: Barriers are typically not recommended on low speed urban roads and streets (local roads and streets are usually posted 35 mph or less) because:

- Low speeds make roadway departure crashes less likely and less severe
- Urban zones require higher access that would be hindered by barriers
- Urban zones have many more intersections that make barrier installation impractical

Small Sections with Short Drop-offs: Barriers are typically not recommended to protect small critical fill slope sections of roadway (less than 100 feet along centerline) with drop-offs less than 10 feet because the risk from a vehicle encroaching this section is less than the risk of striking a barrier system.

Utility Poles: In many cases utility poles are within TDOT right-of-way and are often in the clear zone of rural highways. It is impractical and infeasible to install barriers to protect every utility pole. During the planning of new projects, coordination should be made with the utility company to relocate the poles as far away from the edge of the roadway as possible to mitigate risk. For poles that cannot be moved away from the clear zone the poles should be delineated. Utility owners currently occupying TDOT right-of-way may be asked to evaluate feasible alternatives as required by Title 23 U.S.C. for relocation within or outside of State right-of-way.

TDOT ROADWAY DESIGN GUIDELINES – PDN
CHAPTER 2 GEOMETRIC DESIGN CRITERIA

English

Revised:

2-302.06 BARRIER LENGTH OF NEED

Once the need for a barrier is determined the next step is to calculate the amount of barrier needed. The distance required is referred to as “Length of Need” (LON). There are two types of hazards. The first one is a single obstacle (a rigid object) located inside the traversable clear zone, which will have shorter LON since the full width of clear zone will not be used during the determination of the length. The second one is a non-traversable obstacle such as a river. Non traversable objects travel beyond the maximum clear zone distance therefore LON calculations use max clear zone distance. Most of the time, the beginning of the critical fill slope approaching a bridge for a stream crossing determines the area of concern, therefore it will determine the LON.

As the clear zone distance to a single object or non-traversable object will vary for the opposing traffic, the LON will change at the trailing end as well. The Designer should pay extra attention calculating LON inside the horizontal curves since clear zone distances are 10 to 50 percent larger than the tangent sections. If warranted, the Designer should consider extending the trailing end of guardrail installation to contain errant vehicles failing to negotiate the outside of the curve as a good safety practice. The Roadway Safety Plan Standard Drawing series drawings show typical installations for various cases.

- **S-PL-1:** LON along the roadway for objects or hazards (Warrants 1, 2 and 3)
- **S-PL-3:** Minimum guardrail installation length for bridge ends. Designer must confirm LON requirement. (Warrant 1)
- **S-PL-4:** Minimum freeway bridge pier protection installation details. Designer shall calculate the minimum LON required. (Warrant 2)
- **S-PL-5:** Typical guardrail placement to protect grade separated bridge ends in the depressed median (Warrant 1)

2-302.07 BARRIER TYPE SELECTION CRITERIA

Utilize the following guidelines to determine the appropriate system. See appropriate Roadway Standard Drawings for installation details of each system, S-PL-6 and S-PL-6A.

A) BARRIER TYPE SELECTION CRITERIA FOR WARRANTS 1 THROUGH 3

Typical structural features placed within the clear zone distance: bridge piers, abutments, retaining walls, overhead sign supports, etc.

- a. If the distance from the edge of shoulder to the object is less than 5 feet, use concrete median barrier S-SSMB-3 or S-SSMB-2
- b. If the distance from the edge of shoulder to the object is greater than 5 feet, use guardrail. See Roadway Standard Drawing S-PL-6.
- c. Some roadway features are critical such as bridge piers or MSE type retaining walls and are vulnerable to impact forces. Designers should communicate with the Structures Division to evaluate the design and select proper roadside safety hardware (TL-5 or TL-6) to protect such features and motorists.

TDOT ROADWAY DESIGN GUIDELINES – PDN
CHAPTER 2 GEOMETRIC DESIGN CRITERIA

English

Revised:

B) BARRIER TYPE SELECTION CRITERIA FOR WARRANT 4

- a. By design, highways separated by medians offer a safer operational environment on high speed facilities providing desirable traversable clear zone distances for errant vehicles to recover. However, Designers should evaluate the rare possibility of run-off-the road lane departure and evaluate if the facility needs cable barrier. Refer to [Chapter 2-305.00, Cable Barriers](#) for Cable Barrier evaluation criterion. Follow the guidance provided on Roadway Standard Drawing S-PL-6A, *Safety Hardware Placement in Median* for guidance provided to select appropriate hardware type based on site conditions.

2-303.00 GUARDRAIL

A guardrail system consists of rail, connections, terminals, and anchors. Guardrail consists of metal W-Beam rail supported by wooden post with wood blockouts or steel posts with wood or composite blockouts. If required for special conditions, powder coated alternative with corresponding pay item numbers may be used.

For a W-beam guardrail installation to perform properly, the system must be anchored at both ends to maintain tension (See Roadway Standard Drawings S-GRA series). Approach ends of guardrail must be terminated with an approved crashworthy end terminal with an earth pad (see [Chapter 2-306.02, Guardrail End Terminals](#)). If the trailing end is located outside the clear zone an anchor may be installed at the trailing end in lieu of a terminal to maintain tension on the GR system.

To ensure proper embedment depth for guardrail post, use 8' long post option for all roadway fill sections 6:1 and steeper. Relocating slope break two feet behind the guardrail face will provide needed embedment depth eliminating the need for 8' post. Performance of the guardrail system will be affected when used in conjunction with curbing (6" vertical or slope), or an offset placement from the edge of travelled lane due to placement of sidewalk, shared-use-path, etc. Refer to S-PL-6 for installation guidance.

At the point of impact, semi-rigid guardrail dynamic deflection may reach up to five feet. To provide the system with working room to perform, provide five feet behind the face of guardrail. This zone should be kept clear of rigid obstructions.

Double-sided guardrail (Median Divider Guardrail) may be used in limited cases in the median in place of concrete or cable barriers, particularly when the required length is relatively short. Median divider guardrail is also used when guardrail may be subject to impacts from either side. In cases where the median divider guardrail is installed near the edge of pavement, it is important that the area between the posts is free of asphalt to provide post rotation in soil for the post to perform as designed. See Roadway Standard Drawings S-GR31-1C, S-SSMB-6B or S-SSMB-6E for more details.

TDOT ROADWAY DESIGN GUIDELINES – PDN
CHAPTER 2 GEOMETRIC DESIGN CRITERIA

English

Revised:

2-303.01 GUARDRAIL SPECIAL DESIGNS

Due to site conditions sometimes a guardrail system may not be installed as shown on the standard drawings. However, there are several special installations that may be utilized.

Guardrail at Underground Conflicts:

In the case when a utility or pipe culvert prevents driving guardrail posts the Designer shall refer to:

- Roadway Standard Drawing S-GRS-1 if omitting one post or if only one post is affected by the obstruction
- Roadway Standard Drawing S-GRS-3 if guardrail post or posts could not be driven due to underground facilities.

Guardrail across Box Culvert or Slab Bridge:

- In the case when guardrail runs across a box culvert or slab bridge that has fill of less than 3'-4" over the deck, the Designer shall refer to Roadway Standard Drawing S-GRS-2. In this case, the guardrail will be paid for under Item Number 705-01.04 Metal Beam Guard Fence per L.F.
- If the fill is greater than 3'- 4", guardrail will be installed in the typical method as shown on Roadway Standard Drawing S-GR31-1. In this case, the guardrail will be paid for under Item Number 705-06.01 W Beam GR (Type 2) Mash TL3 per L.F.

Guardrail at Intersections:

When the length of need for guardrail extends beyond the location of an intersection or a driveway, the guardrail shall be curved around the intersection radius and type in-line anchors installed as shown on Roadway Standard Drawing S-PL-2. When curved guardrail cannot be installed due to extreme site limitations, the Designer shall terminate the guardrail and install an in-line anchor (see S-GRA-4) to provide downstream tension for the GR system. Every effort should be made to locate the GR end as far away from the moving traffic to reduce crash severity. Such locations should be further evaluated to confirm if LON is provided.

Guardrail at Steep Slopes:

When a guardrail must be installed where the 2' earth pad behind the post cannot be installed on a slope steeper than 6:1, the length of the posts shall be increased to 8'. See Roadway Standard Drawings S-PL-6 and S-GR31-1 through S-GR31-1C.

Guardrail Height Transition Detail:

When MASH evaluated 31" GR has to be connected to existing 27" GR, the guardrail shall receive a transition section no steeper than 1" per span (6'-3 1/2") vertical taper. See Roadway Standard Drawing S-GRS-4.

TDOT ROADWAY DESIGN GUIDELINES – PDN
CHAPTER 2 GEOMETRIC DESIGN CRITERIA

English

Revised:

2-304.00 CONCRETE MEDIAN BARRIERS

Concrete Barrier is a rigid barrier consisting of a 36" or 51" tall concrete wall offering MASH TL-4 and TL-5 performance. See Roadway Standard Drawings – S-SSMB series for details. The 51" wall should be the Designer's first choice at all locations where satisfying sight distance is not critical. The 51" wall serves as a glare screen to limit headlight glare from opposing lanes in urban areas. TDOT utilizes a single slope wall. At impact, the barrier wall does not deflect resulting in a near sudden deceleration for the occupant of the impacting vehicle. Because of the sudden deceleration, the system should only be used when the level of protection is required. The barrier is best suited:

- To prevent crossover crashes at narrow, at grade medians.
- To prevent catastrophic damage to structures near the roadway.
- To prevent outside the curve run-off-road incidents for large vehicles.
- To limit the zone of intrusion of a large vehicle box and to limit the tilt angle.

The blunt ends of concrete median barrier walls are considered a roadside hazard because of their unyielding nature. The ends must be protected by means of an approved crash cushion (attenuator). Guardrail to concrete barrier transitions require a three beam transition section to prevent the guardrail from deflecting, creating a pocket that would allow a vehicle to impact the end of the wall. See Roadway Standard Drawings S-SSMB-6 through S-SSMB-6F and Roadway Standard Drawings – Guardrail Connections series for details of the semi-rigid transition guardrail.

2-305.00 CABLE BARRIERS

Cable barrier systems are typically installed at existing four lane divided highways with traversable depressed medians wider than minimum clear zone distance. Cable barriers may be used to mitigate locations experiencing the severe run-off-the-road left crash density or as an improved safety measure, to reduce crash severity. Cable barriers are designed to perform for impacts on either side; thus, only one run may be installed. For recoverable, 4:1 or flatter fill slopes. High tension cable barrier consists of three or four high tension steel cables supported by steel posts. Cable barriers require an anchor to provide the tension, as well as, salvage type fittings to adjust and maintain tension for the system to perform under the desired performance criteria. At the point of impact, cable barriers typically deflect up to 11 feet. In order to maintain maximum 10' deflection performance from a cable barrier system, the installed length shall not exceed 5000 ft from anchor to anchor with maximum 11' post spacing and initial tension as shown on Standard Drawing S-CB-2 Table B. Because of the deflection, cable barriers are not suited to shield objects close to the roadway or narrow medians. If proposed at these locations, use a reduced post spacing to limit the deflection rates.

The performance of high tension cable barrier systems depends on soil specific design of the anchoring system. Cable Barrier Terminals should not be included in the length of need since they do not offer re-directive capacity, but they are designed to be crashworthy. Terminals should be overlapped by another barrier system, if continuous barrier protection is needed while

TDOT ROADWAY DESIGN GUIDELINES – PDN
CHAPTER 2 GEOMETRIC DESIGN CRITERIA

English

Revised:

transitioning from one hardware type to the other. Shorter runs of cable barrier systems that overlap are advantageous to maintain tension across critical areas. See Roadway Standard Drawing Series S-CB for cable barrier installation guidance.

2-306.00 END TREATMENTS

To prevent the end of barrier systems from becoming hazards to the driving public, the ends must be anchored and protected with either an attenuator or end terminal if they are located within the clear zone. The following sections provide the design considerations for Anchorages, Guardrail End Terminals, and Crash Cushions.

2-306.01 ANCHORAGES

For guardrails to function properly both ends must be anchored to provide the system with tension. Guardrail anchors are shown in the Roadway Standard Drawings – S-GRA Guardrail Anchor Series.

In cases where the end treatment is facing oncoming traffic and within the clear zone, an end terminal is required. The anchor is installed with the terminal (Type 38, or Type 21). Note: There is no separate anchor standard drawing for a Type 21 or Type 38 anchor since it is proprietary and is included in the cost of the end terminal.

When the end of the guardrail is located outside the clear zone of oncoming traffic or the trailing end of a guardrail that is outside the clear zone of opposing traffic, a crashworthy end treatment may not be required. In this case the Type 13 anchor may be installed.

When a guardrail is curved around an intersection or driveway, an anchor is installed along the tangent section of guardrail near the point of curvature to maintain system tension. In this case, an In-Line anchor is installed per Roadway Standard drawing S-GRA-4 as a best engineering practice to reduce crash severity. When site conditions permit, Designers should always prefer curved guardrail installation following the Roadway Standard Drawing S-GRS-7. Again, S-GRA-4 is for use on non-NHS roads; S-GRS-7 is for NHS roads; they are not interchangeable.

TDOT ROADWAY DESIGN GUIDELINES – PDN
CHAPTER 2 GEOMETRIC DESIGN CRITERIA

English

Revised:

2-306.02 GUARDRAIL END TERMINALS

On every road the first choice for approach end terminal shall be the buried in backslope, Guardrail End Terminal (Type 12). See Roadway Standard Drawing S-GRT-1. This system is non-gating meaning the entire system is designed to redirect a vehicle. The buried in backslope end terminal requires a backslope of 2:1 or steeper. Guardrail lengths may be extended up to 200 feet to a section of backslope meeting the backslope requirements. When the above required conditions cannot be achieved, the Designer shall use the following guidance to choose the appropriate system:

On roadways with posted speeds greater than 45 mph, the tangential energy absorbing guardrail end terminal (Type 38) shall be used. See Roadway Standard Drawing S-GRT-2. For the system to work as designed, the earth pad as shown on Roadway Standard Drawing S-GRT-2P must be installed. Only SOFTSTOP provides re-directive capacity at the first post at determined GR need point (LON). At restrictive sites, Designers shall use SOFT STOP to reduce the installation length by two posts (12.5')

On roadways with posted speeds less than 45 mph, Type 21 (TL-2) terminals may be used instead of a Type 38. See Roadway Standard Drawing S-GRT-3. For the system to work as designed, the earth pad as shown on Roadway Standard Drawing S-GRT-2P must be installed.

If standard bridge parapet wall transitions and guardrail terminals are unable to meet the length of need installation requirements due to site limitations, a Curved Parapet Wall detail may be used on facilities with speeds less than or equal to 40 mph. See Roadway Standard Drawing S-CPW-1.

2-307.00 CRASH CUSHIONS

Crash cushions (impact attenuators) are used to shield fixed roadside objects located within the clear zone such as bridge piers, overhead sign supports, ends of retaining walls, concrete median barriers, bridge abutments, and bridge railings, etc. Crash cushions operate based on energy absorption or energy transfer by either decelerating a vehicle to a controlled stop after a frontal impact, or by redirecting a vehicle away from a fixed object after a side impact. Where a fixed roadside object is identified, the Designer should first consider removing, relocating, making the object breakaway, or shielding the fixed object with a longitudinal barrier. Where this is impractical, the use of an approved crash cushion system should be considered.

All crash cushions shown on TDOT Qualified Product List 34 are evaluated under NCHRP 350 and TDOT Qualified Product List 45 are evaluated under the AASHTO Manual for Assessing Safety Hardware (MASH) for Test Level 3 (TL-3) or Test Level 2 (TL-2). This requirement shall apply to all temporary work zone and permanent installations.

TDOT ROADWAY DESIGN GUIDELINES – PDN
CHAPTER 2 GEOMETRIC DESIGN CRITERIA

English

Revised:

2-307.01 CRASH CUSHION WORK ENERGY PRINCIPLE (NON-GATING, RE-DIRECTIVE SYSTEMS)

Crash cushion design based on the work-energy principle involves the reduction of an impacting vehicle’s kinetic energy to zero. If a vehicle will be stopped after an impact, then the “work” done on a vehicle equals the initial kinetic energy of the vehicle. An impact to a crash cushion will result in some damage to a vehicle; however, under the work-energy principle, the potential for serious injury to the vehicle occupants is reduced.

Crash cushions that operate under the work-energy principle utilize “crushable” or “deformable” material to convert the kinetic energy of a vehicle into other forms of energy including mechanical, potential, heat, and sound energy. Crash cushions of this type, referred to as compression crash cushions, require a rigid support backup structure or foundation to resist the impact force of the vehicle utilizing the energy-absorbing material. These types of crash cushions are considered non-gating, re-directive systems, in that they are not intended to capture the vehicle upon impact (unless frontal impact occurs); but rather, redirect the vehicle after collision. Various systems are available that offer re-directive capabilities on one or both sides of the system.

Table 2-2, Non-Gating Re-directive Crash Cushion Classification summarizes the three types of non-gating/re-directive crash cushion systems considered acceptable for use on TDOT projects. See *Figure 2-8, Crash Cushion Selection Flowchart* for selection flowchart.

Non-Gating Crash Cushion Classification	Roadway Location Characteristics			
	ADT	Impact Frequency per Year	Distance (D) from Travel Way (feet)	Repair Considerations
Reusable	<25,000	1-2	D>10	Many reusable components, Unlimited repair time
Low Maintenance	≥25,000	3 or more	D≤10	Time and workspace limitations
Self-Restoring	≥25,000	3 or more	D≤10	Multiple hits before repairs needed

Table 2-2
Non-Gating Redirective Crash Cushion Classification

TDOT ROADWAY DESIGN GUIDELINES – PDN
CHAPTER 2 GEOMETRIC DESIGN CRITERIA

English

Revised:

**2-307.02 CRASH CUSHION CONSERVATION OF MOMENTUM PRINCIPLE
(GATING SYSTEMS)**

The conservation of momentum principle for crash cushion design involves the transfer of the vehicle's momentum to an expandable mass of material located in the vehicle's path. The conservation of momentum principle is involved with all crash cushion impacts, since some portion of a vehicle's kinetic energy is transferred to the cushion by accelerating and moving various components of the cushion during an impact. For gating systems, this expandable mass will normally consist of containers filled with sand. Sometimes referred to as inertial crash cushions, these types of systems require no rigid backup or support to resist a vehicle's impact force and may be used for both temporary and permanent installations.

Gating systems are energy dissipation devices only and rely on the conservation of momentum principle. They have no capability to re-direct an errant vehicle but will either capture a vehicle or allow it to pass through the system along the same general path. Use of a gating crash cushion should be limited to locations where the roadside object is not likely to be impacted at an angle on the side with any significant velocity or when no other safety device product will fit the location (i.e. very wide hazards). Also, gating systems may be appropriate for use on low speed facilities and in temporary work zones with higher speeds where lane widths are constrained and the potential for a high angle impact is limited. Every gating system must be specifically designed for the fixed object it is intended to shield.

For gating, non-redirective systems (i.e. sand-filled barrel arrays), the Designer should verify that adequate clear run-out area is available behind the device. Barrel arrays should not be used where there is high potential for vehicles to impact the device in the reverse direction (e.g. a vehicle would hit the heaviest barrels placed directly adjacent to the fixed object being shielded).

2-307.03 CRASH CUSHION SELECTION GUIDELINES

The location of all permanent crash cushions should be shown on the Proposed Layout sheets along with the cushion type for each occurrence of a crash cushion on the project. In addition, the Designer should provide the available reserve area (length and width after deducting for offsets - see Roadway Standard Drawing S-CC-1) for each location where a crash cushion is to be installed. The Designer will specify the type of crash cushion to be used, and the contractor will choose an approved product for that type selected. In some instances, it may be necessary to provide special details for a given location. When special details are required, they should be shown on the Detail Sheets in the plans.

For new construction projects, use *Figure 2-8 Crash Cushion Selection Flowchart* to determine the appropriate type of crash cushion to specify, see Roadway Standard Drawing S-CC-1 for more details. Maintenance projects shall follow the maintenance contract. See Roadway Standard Drawing S-GR28 series.

TDOT ROADWAY DESIGN GUIDELINES – PDN
CHAPTER 2 GEOMETRIC DESIGN CRITERIA

English

Revised:

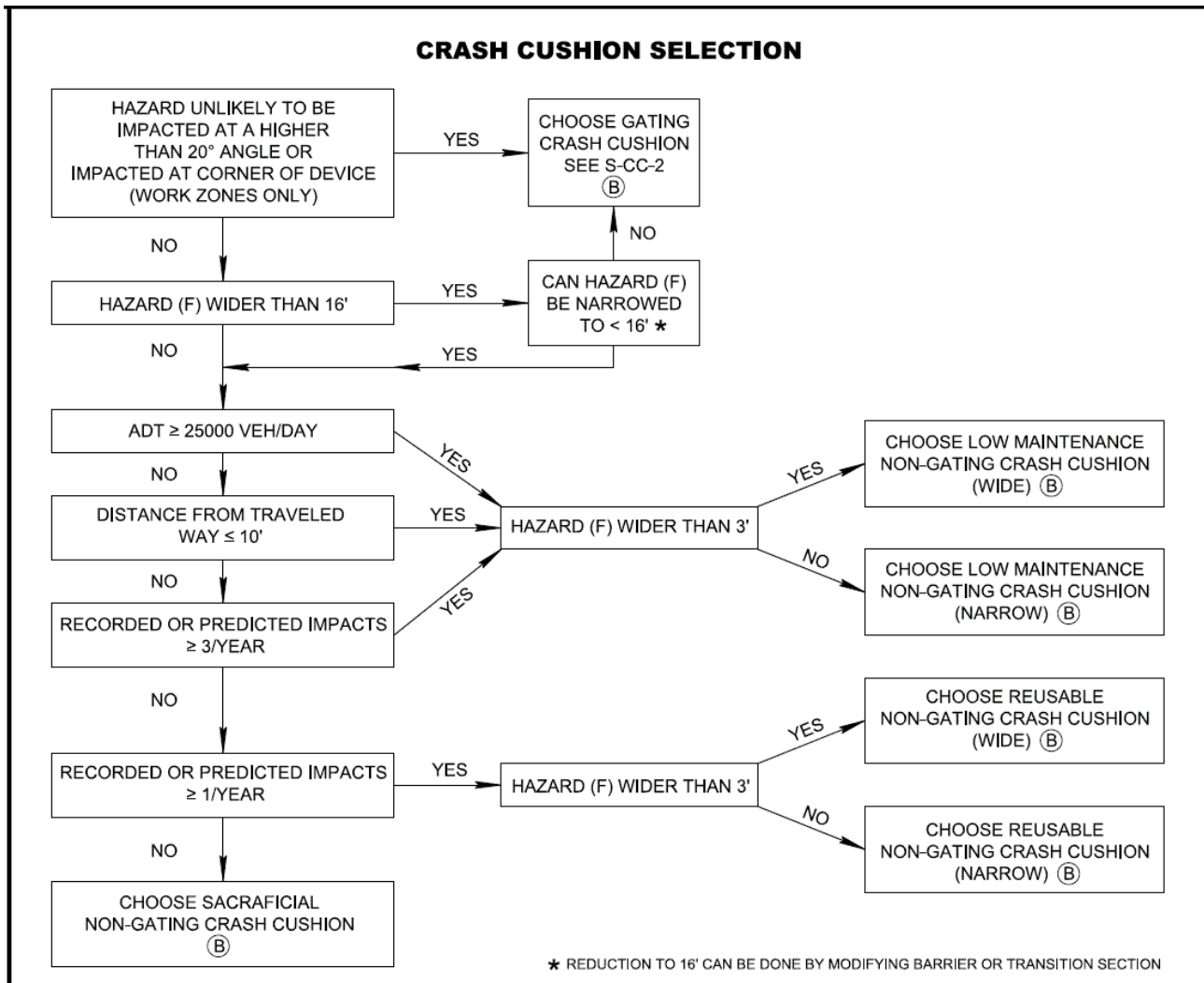

Figure 2-8
Crash Cushion Selection Flowchart

*Reduction to 16' can be done by modifying barrier or transition section
 (From Roadway Standard Drawing S-CC-1, see note B)

2-307.04 CRASH CUSHION SELECTION BASED ON SITE CHARACTERISTICS

Provisions for providing adequate space (reserve area) for crash cushions to shield fixed objects should be made during the Functional Design Plans stage for new roadway construction projects and for the rehabilitation or reconstruction of existing roadways. Roadway Standard Drawing S-CC-1 provides the minimum and desired reserve area dimensions that should be made available. The preferred condition represents the optimum and desirable values for any location. The unrestricted conditions represent the minimum dimensions for all locations. The restricted conditions shall be used only where it can be demonstrated that dimensions of the unrestricted

TDOT ROADWAY DESIGN GUIDELINES – PDN
CHAPTER 2 GEOMETRIC DESIGN CRITERIA

English

Revised:

condition are unattainable. The information in the table is for preliminary design purposes. Final design should be based on the crash cushion system selected and the manufacturer's specifications. Additionally, the table values are generic and may not apply to some proprietary systems.

To allow crash cushions to compress uniformly during an impact, systems should be installed on a hard, smooth, and generally flat surface of asphalt or concrete (preferred). All non-gating systems will require a foundation of this type. This can easily be accommodated for new construction; however, at retrofit locations or major roadway rehabilitation sites, the Designer should attempt to remove sloped surfaces as part of the project plans. Longitudinal and transverse slopes in excess of 5 percent should be avoided. Additionally, if the cross slope varies by more than 2 percent over the length of the system, the Designer may need to make site alterations. For gating systems, the hard-flat surface should be placed to provide a uniform foundation on which the barrel-array pattern may be installed, and the design masses of the sand-filled barrels can be marked. These marked locations will aid in the proper reconstruction of the barrel system to its originally designed capacity and configuration after a vehicle impact.

On new construction projects, no curb, curb and gutter, or raised pavement should be designed in the area surrounding or occupied by the crash cushion. When retrofitting an existing location, existing curbs, curb and gutter, or raised pavement should be removed where possible. If an existing curb is to remain, it shall be no more than 4 inches in height. The Designer should also verify that the existing curb has not previously contributed to poor crash performance.

The Designer should verify if sight distance will be compromised by installing a crash cushion at some intersection locations (i.e. locations at the end of concrete median barriers located at at-grade intersections). Where this is a concern, the Designer should choose a system that provides reduced overall height while still meeting the attenuation need at the location.

2-307.05 CRASH CUSHIONS IN TEMPORARY WORK ZONES

For temporary work or construction zones, the Designer should select a crash cushion system consistent with the expected time and site conditions that may be present at the given location. If the posted speed limit is greater than 45 mph, crash cushions installed in temporary work zones shall meet Test Level 3 criteria and each system must be listed on the Qualified Products List. Temporary systems shall be selected, designed, and installed based on the same guidance provided for permanent applications.

Non-gating, re-directive systems are approved for use in temporary work zones and available in narrow widths giving the ability to satisfy attenuation requirements where working conditions are constrained, provided that a paved surface is available for proper anchorage.

With all temporary applications, the selected system should provide adequate separation distance between the installed system and the actual area where work is being performed due to the possibility of flying debris during an impact. Additionally, sight distance at intersecting

TDOT ROADWAY DESIGN GUIDELINES – PDN
CHAPTER 2 GEOMETRIC DESIGN CRITERIA

English

Revised:

roadways or points of ingress/egress to the work zone should be considered and checked during the selection process.

2-308.00 CHECKING DRAINAGE PLANS PRIOR TO CONSTRUCTION

Before finalizing drainage plans, the Designer is to ensure that the drainage portion of the PS&E plans is consistent with current standard drawings. This will consist of making sure that the invert elevations shown on the proposed plan sheets facilitate the use of standard small drainage structures. The Designer is to use the same invert drop across the structures that are used on the standard drawings. This check must be completed prior to submitting the PS&E plans. It is necessary to make this adjustment in order to eliminate costly construction changes to the catch basins, manholes, junction boxes, etc. Check depth for 10 ft. or deeper structures for constructability prior to the PS&E Field Review.

Invert elevations are to be shown in the plans for all pipes entering and leaving these small drainage structures. The grate elevation is to be shown for all catch basins. The top of lid elevation is to be shown for all manholes. The top of slab elevation is to be shown for all junction boxes. The proper tabulation of these structures is shown in the TDOT Drainage Manual.

TDOT ROADWAY DESIGN GUIDELINES – PDN
CHAPTER 2 GEOMETRIC DESIGN CRITERIA

English

Revised:

SECTION 4 – SIGNS

2-400.00 ROADWAY SIGNING SHEETS DEVELOPMENT GUIDELINES

The development of signing plans and sign schedule sheets is the responsibility of the Design Office preparing the roadway plans. A Designer is assigned in each regional Design Office to serve as the Signing Designer. The Signing Designer is responsible for development of all roadway signing and sign schedule sheets for projects developed in the region. In addition, the Signing Designer will provide signing, item numbers, quantities, signing details, standard drawings, and signing notes to roadway Designers. See Traffic Operations Division, [Traffic Design Manual, Module 3: Signing and Pavement Marking Design](#) and [Traffic Operations Sign Policy, Design and Programs Section](#) webpage for more guidance.

The Roadway Design Manager will be responsible for determining whether the Signing Designer or the Roadway Designer will be responsible for CADD work to place signing on plans sheets for individual projects.

The Design Manager will be responsible for determining if Signing and/or Pavement Marking sheets are needed on projects other than freeways and full-access controlled highways. On all other projects, the proposed signing will normally be located on the proposed layout sheets. On projects utilizing pavement marking sheets, proposed signing should be shown on the same sheets.

The workflow for preparation of roadway signing plan sheets is as follows:

1. At the start of the Functional Design Phase, the Designer will provide a PDF set of plans, proposed layout sheet (or signing and marking sheet files) CADD files to the regional signing Designer to develop signing and sign schedule sheets.
2. After developing signing and sign schedule sheets, the Signing Designer submits a PDF file to Regional Traffic Engineering Office for review.
3. The Regional Traffic Engineering Office reviews the proposed signing and provides the Signing Designer with any comments.
4. The Signing Designer makes any needed changes and submits a PDF file of the proposed Signing Sheets and Sign Schedule sheets to the Traffic Operations Division, Headquarters Traffic Engineering Office (TDOT.TrafficOps.Sign-Reviews@tn.gov) for review.
5. The Signing Designer submits the proposed signing and sign schedule sheets to the Roadway Designer at the PS&E Plan Review, which is eight weeks prior to PS&E plans turn-in.

Freeway and full access control projects

For freeway and full access control projects Signing and Pavement Marking sheets will be developed for placement of signing and pavement markings.

TDOT ROADWAY DESIGN GUIDELINES – PDN
CHAPTER 2 GEOMETRIC DESIGN CRITERIA

English

Revised:

The Signing Designer should coordinate with the Roadway Designer concerning any design issues that may arise during the development of the signing plans. The Signing Designer should coordinate with the Structures Division to have overhead, cantilever, or bridge mounted structures be designed and structural standard drawing numbers are received.

Consultant Projects

For projects developed by design consultants, signing will be developed by the consultant Designer. The consultant will be responsible for furnishing PDF plans and CADD files to the Roadway Design Lead when construction plans are started. The Roadway Design Manager will forward the information to the Signing Designer to develop project signing as outlined above.

Other Projects

On projects (resurfacing, bridge replacement, etc.) requiring no more than three sizes of permanent signs, the Designer may place Traffic Operations Standard Drawing T-S-20 Sign Details in the Index of Standard Drawings. The Designer will need to show the proposed location and designate the type of sign (R1-1, R1-2, TN-5, etc.) on the plans. These signs will be paid for per each under Item Numbers. 713-16.20 through 713-16.39. Appropriate Foot Notes, General Notes, and Standard Drawings will also need to be included.

If any sign needed for a project is not included on Traffic Operations Standard Drawing T-S-20, or if there are any questions, contact the Regional Design Office Signing Designer for further guidance.

TDOT ROADWAY DESIGN GUIDELINES – PDN
CHAPTER 2 GEOMETRIC DESIGN CRITERIA

English

Revised:

**2-401.00 ADVANCE GUIDE SIGNS AND EXIT DIRECTIONAL SIGNS ON
TRAFFIC CONTROL PLANS**

The Designer shall include advance guide signs and exit directional signs (green and white signs) on all phases of the traffic control plan for projects on access controlled highways including interchange cross streets. Advance guide signs and exit directional signs should also be shown on the traffic control plan on access controlled resurfacing projects when the traffic control phasing requires the placement of temporary pavement markings which conflict with directional signs or requires directional signs to be relocated or adjusted. It will be the Designer's responsibility to prepare any required traffic control sheets for all phases showing the layout and location of all directional and guide signs. Supplemental signing is not required to be shown.

Existing signs should be used as part of the traffic control plan for as long as possible throughout the different construction phases provided signs are located in accordance with MUTCD and do not provide inaccurate information. The most common conflict of existing signing with new construction occurs when overhead guide signs with down arrows or diagrammatic signs displaying lane lines are over lanes that are closed during certain construction phases. Once existing signs cannot be used at the original location, the Designer should attempt to relocate the existing sign or place the permanent sign. If relocation or placement of the permanent sign is not feasible, a new temporary advance guide sign or exit directional sign shall be shown on the traffic control plan for the affected construction phase and for any other construction phase the sign is needed. Sign location shall conform to the MUTCD. Sign size should be the same as the sign removed if feasible. There shall be at least one temporary advance directional and temporary exit directional for each exit on the project.

For signs located on overhead structures, the Designer should contact the Traffic Operations Division, Traffic Operations Sign Policy, Design and Programs Section (TDOT.TrafficOps.Sign-Reviews@tn.gov) and the Regional Traffic Engineer for additional guidance.

The following guidance should be used when it is necessary to install temporary exit directional signs or temporary advanced guide signs. The Designer should contact the Traffic Operations Division, Traffic Operations Sign Policy, Design and Programs Section (TDOT.TrafficOps.Sign-Reviews@tn.gov) or the Regional Traffic Engineer for any additional technical questions or guidance required.

1. In the event it is not feasible to replace an exit directional sign with the existing sign size, the new sign shall be 48" x 96", 0.100" sheet aluminum. The letters will be minimum 8 inch "D" (all capital) letters and there will be a 3/4" border with a 2" radius. The color will be a reflective green background with a reflective white copy. The supports will be included in the sq. ft. of the sign face as it is with other construction signs.

TDOT ROADWAY DESIGN GUIDELINES – PDN
CHAPTER 2 GEOMETRIC DESIGN CRITERIA

English

Revised:

2. The information on exit directional signs should be the same as the information on the existing signs that were removed. There shall be no more than four lines of copy on these signs. The layout of these signs should look as close to the existing as possible.
3. On advanced guide signs; the first line shall be the exit number for the interchange (i.e. EXIT 234), the second line will be the first destination (i.e. OLD HICKORY BLVD), the third line will be the second (i.e. MADISON), the fourth line will be NEXT RIGHT (Center all lines of copy). These signs should be located no closer than one half mile from the exit directional sign.
4. The exit directional sign shall have the same exit number and destinations as the advance guide but in lieu of NEXT RIGHT there will be a type “B” arrow at a 45 degree angle to the right. (Center all lines of copy.) These signs should be located at the beginning of the taper for the appropriate exit ramp.
5. If an interchange has a TN (TN-6a -TN-6d) or U.S. (M1-4) route shield on the directional signing, then a shield, and if needed, a cardinal direction (M3-1 –M3-4) shield, will be shown mounted to the left support under both the advance and exit directional signs.
6. If more lines of copy are needed, then the Designer can add a 24” x 96” or another 48”x 96” aluminum sheet to the bottom of the first sign, but the size shall not be larger than a total of 96”x96”.
7. Removal of existing signs shall be paid for under item number 713-15, Removal of Signs, Posts, and Footings, Lump Sum.
8. New signs shall be paid for under item number 712-06, New Signs (Construction), per S.F. Team Leads should contact the HQ Construction Office to have item numbers assigned when the traffic control plan involves relocating existing signs.
9. See Chapter 9-160.00 for notes to be placed in the General Notes on all access controlled and freeway projects and on access controlled and freeway resurfacing projects when the traffic control phasing requires placement of temporary pavement markings which conflict with directional signs or requires directional signs to be relocated or adjusted.

If advance guide signs or exit directional signs are included in the traffic control plan, the Designer or Design Manager (for consultant projects) shall upload the traffic control plan to FileNet and an email notification sent to the Traffic Operations Division, Traffic Operations Sign Policy, Design and Programs Section (TDOT.TrafficOps.Sign-Reviews@tn.gov). See PDN for more information. For resurfacing projects with advance guide signs or exit directional signs, plans should be sent as soon as possible. Only traffic control plans with advance guide signs or exit directional signs shall be sent to the Traffic Operations Division, Traffic Operations Sign Policy, Design and Programs Section for review.

The Designer shall place a copy of the email in the project folder to document the submittal of traffic control plans for advance guide or exit directional signing review.

The naming convention for the traffic control plan PDF will include the PIN and the Region #, **nnnnnn-nn-TrafficControlReview-RegX.pdf**. If there are modifications to the traffic control

TDOT ROADWAY DESIGN GUIDELINES – PDN
CHAPTER 2 GEOMETRIC DESIGN CRITERIA

English

Revised:

plans that affect the advance guide signs or exit directional signs, then the naming convention will be ***nnnnn-nn-TrafficControlReview-RegX-Rev-00-00-00.pdf***. The revised traffic control plan review request will contain all traffic control sheets.

Example: 123456-00-TrafficControlReview-Reg1.pdf

2-402.00 HISTORICAL MARKERS

On projects impacting a Tennessee Historical Marker sign, the Designer shall add Item Numbers 713-16.50 to 713-16.60 “Remove and Replace Sign (description)” per EACH to the quantities, as needed. The Designer shall also add special note from Chapter 9-220.00.

TDOT ROADWAY DESIGN GUIDELINES – PDN
CHAPTER 2 GEOMETRIC DESIGN CRITERIA

English

Revised:

SECTION 5 – PAVEMENT MARKINGS

2-500.00 PAVEMENT MARKING GUIDELINES

These guidelines are general in nature for average-type projects. It is not intended that these guidelines supersede the exercise of good engineering judgment in the development of a pavement marking plan for a project. Special problem areas may require special treatment, that shall be determined at or prior to the PS&E Field Review. Traffic volumes may be found in the project specific traffic reports, ETRIMS or the Strategic Transportation Investments Division latest [Traffic Flow Maps](#).

Permanent striping will consist of both centerlines and edge lines on all pavements with a minimum total width of 16 feet.

If surface materials other than hot plant mix asphalt (such as cold mix asphalt, DBST, etc.) are applied, no temporary or permanent centerline markings will be required, since these surface materials would be incapable of retaining the pavement markings.

See Chapter 2-501.00 through 2-502.00 for guidance for temporary and permanent pavement marking and Chapter 9-135.00 for pavement marking general notes.

See [Traffic Design Manual, Module 3: Signing and Pavement Marking Design](#).

2-501.00 TEMPORARY PAVEMENT MARKINGS

Temporary pavement markings on the intermediate layers of pavement open to traffic will be installed to permanent standards daily with reflectorized paint or the approved QPL equivalent. If there are no centerline pavement markings on the existing roadway before the proposed construction or resurfacing project begins, no temporary centerline pavement markings will be required on the roadway during construction.

The temporary pavement markings will be paid for under Item Number 716-05.01, Painted Pavement Marking (4" Line) per L.M., Item Number 716-05.20, Painted Pavement Marking (6" Line), per L.M., Item Number 716-05.02, Painted Pavement Marking (8" Barrier Line), or Item Number 716-05.49, Painted Pavement Marking (8" Line) per L.F.

If the permanent marking material is thermoplastic, the contractor may elect to mark the final layer of pavement with reflectorized paint to permanent standards daily and wait until the paving operation has been completed before the permanent markings are installed. In this case, the temporary markings for the final layer will not be measured and paid for directly, but the costs are to be included in the price bid for the permanent markings.

TDOT ROADWAY DESIGN GUIDELINES – PDN
CHAPTER 2 GEOMETRIC DESIGN CRITERIA

English

Revised:

2-501.01 TEMPORARY PAVEMENT MARKING FOR USE ON PAVEMENT SURFACE OTHER THAN FINAL

1. ON ALL FREEWAYS AND CONTROLLED ACCESS ROUTES (During Construction)

A. On Non-Transition Sections:

- a. **Lane lines** – use 8” painted white skip lines (Item Number 716-05.49, Painted Pavement Marking (8” line)) and white raised pavement markers (716-01.06, Temporary Raised Pavement Marker, White) on 40’ spacing.
- b. **Left edge lines** (yellow) – Use 8” painted solid yellow lines (Item Number 716-05.49, Painted Pavement Marking (8” line)) and yellow raised pavement markers (Item No. 716-01.07, Temporary Raised Pavement Marker, Yellow) on 20’ spacing.
- c. **Right edge lines** (white) – Allow as equals:

Use 8” solid white wet-reflective temporary tape (according to manufacturer’s specifications). (Item No. 712-09.21, Removable Wet Reflective Pavement Marking Tape),

Use 8” painted solid white lines (Item No. 712-09.02, Removable Pavement Marking (8” barrier line)) with an approved white barrier rail delineator on top of barrier rail (Item No. 712-04.50, Barrier Rail Delineator) on 20’ spacing, **OR**

Use 8” painted solid white lines (Item No. 716-05.49, Painted Pavement Marking (8” Line)) only with white flexible delineators (Item No. 712-04.10, Temporary Flexible Tubular Delineator) at outside edge of shoulder on 20’ spacing when no barrier rail is present.

B. On Transition Sections

- a. **Lane lines** – Use 8” painted solid white lines (Item No. 716-05.49, Painted Pavement Marking (8” Line)) and white raised pavement markers (Item No. 716-01.06, Temporary Raised Pavement Marker, White) on 20’ spacing.
- b. **Left edge lines** (yellow) – Use 8” painted solid yellow lines (Item No. 716-05.49, Painted Pavement Marking (8” Line)) and yellow raised pavement markers (Item No. 716-01.07, Temporary Raised Pavement Marker, Yellow) on 20’ spacing.
- c. **Right edge lines** (white) – Allow as equals:

Use 8” solid white wet-reflective temporary tape (Item No. 712-09.21, Removable Wet Reflective Pavement Marking Tape). (according to manufacturer’s specifications)

Use 8” painted solid white lines (Item No. 712-09.02, Removable Pavement Marking (8” barrier line)) with an approved white barrier rail delineator on top of barrier rail (Item No.712-04.50, Barrier Rail Delineator), on 20’ spacing, **OR**

TDOT ROADWAY DESIGN GUIDELINES – PDN
CHAPTER 2 GEOMETRIC DESIGN CRITERIA

English

Revised:

Use 8" painted solid white lines (Item No. 716-05.49, Painted Pavement Marking (8" Line)) only with white flexible delineators (Item No. 712-04.10, Temporary Flexible Tubular Delineator) at outside edge of shoulder on 20' spacing when no barrier rail is present.

NOTES:

1. Raised pavement markers are to be placed in a single row, not staggered, under all applications.
 2. If Project Engineer has specific recommendations, they should be discussed at the PS&E Field Review.
 3. Missing raised pavement markers shall be replaced:
 - a. at least monthly or,
 - b. at the instruction of the engineer
 4. All raised pavement markers shall be removed before placement of the final pavement surface. The cost of removal shall be included in the price bid for raised pavement markers, Item Numbers 716-01.05 Temporary Raised Pavement Marker per Each, 716-01.06 Temporary Raised Pavement Marker, White per Each, and/or 716-01.07 Temporary Raised Pavement Marker, Yellow per Each.
2. STATE ROUTES WITH 4 OR MORE LANES (Unlit During Construction)
- a. **Lane Lines** – Use 8" wide white painted skip lines (Item No. 716-05.49, Painted Pavement Marking (8" Line)) and raised pavement markers (Item No. 716-01.06, Temporary Raised Pavement Marker, White) on 80' spacing.
 - b. **Edge and center lines** – Use solid lines (yellow or white, as appropriate) with an 8" width. Raised pavement markers (yellow or white, as appropriate) may be specified for use on a case-by-case basis, as determined at the Plan-in-Hand Field Review. Raised pavement markers should not be used on right edge line. When raised pavement markers are used for the left edge line, spacing shall be 20 feet.

NOTES:

1. Raised pavement markers are to be placed in a single row, not staggered, under all applications.
2. If Project Engineer has specific recommendations, they should be discussed at the Plan-in-Hand Field Review.
3. Missing raised pavement markers shall be replaced; at least monthly or, at the instruction of the engineer
4. All raised pavement markers shall be removed before placement of the final pavement surface. The cost of removal shall be included in the price bid for raised pavement markers, Item Numbers 716-01.05 Temporary Raised Pavement

TDOT ROADWAY DESIGN GUIDELINES – PDN
CHAPTER 2 GEOMETRIC DESIGN CRITERIA

English

Revised:

Marker per Each, 716-01.06 Temporary Raised Pavement Marker, White per Each, and/or 716-01.07 Temporary Raised Pavement Marker, Yellow per Each.

3. ALL OTHER STATE ROUTES

- a. **All Lines** – Use 4” marking lines. Centerline yellow raised pavement markers may be considered on a case-by-case basis. Discuss need at Plan-in-Hand Field Review.

NOTES:

1. Raised pavement markers are to be placed in a single row, not staggered, under all applications.
2. If Project Engineer has specific recommendations, they should be discussed at the Plan-in-Hand Field Review.
3. Missing raised pavement markers shall be replaced:
 - a. at least monthly or,
 - b. at the instruction of the engineer.
4. All raised pavement markers shall be removed before placement of the final pavement surface. The cost of removal shall be included in the price bid for raised pavement markers, Item Numbers 716-01.05 Temporary Raised Pavement Marker per Each, 716-01.06 Temporary Raised Pavement Marker, White per Each, and/or 716-01.07 Temporary Raised Pavement Marker, Yellow per Each.

2-502.00 PERMANENT PAVEMENT MARKINGS

The Designer should refer to Tables 2-3A and 2-3B for pavement marking guidelines for all freeways and state routes. In addition to pavement marking guidelines, Tables 2-3A and 2-3B provide guidance for the placement of rumble strips and rumble stripes. This guidance shall be used on all new, reconstruction, and resurfacing projects except in areas which require special treatment as determined at the Plan-in-Hand Field Review and approved by the Project Manager.

Type	Thickness (mils)	Bead Package	Pavement Type				Comments
			Asphalt			Concrete	
			Conventional	OGFC	HFS		
Thermoplastic Spray	60	Type I	X		X	X	Spray Thermoplastic, Multipolymer
Thermoplastic Extruded	100	Type I & IV	X	X Note 1	X	X	Enhanced Flatline Thermoplastic, Multipolymer
Thermoplastic Ribbon	100	Type I & IV	X	X Note 1	X		Enhanced Flatline Thermoplastic with clean borders, Multipolymer

**TDOT ROADWAY DESIGN GUIDELINES – PDN
CHAPTER 2 GEOMETRIC DESIGN CRITERIA**

English

Revised:

Profile Thermoplastic	125	Type IV	X	X	X	X	Audible feedback, Wet visibility Per SP 716PTA
Polyurea	20	Type I	X	X	X		Moisture resistance
Tape	85	NA	X			X	
Specialty Pavement Markings							
Extruded	100	Type I & IV	X Note 2		X Note 2	X Note 2	Enhanced Flatline Thermoplastic,
Pre-formed	90 - 125	N/A	X Note 2		X Note 2	X Note 2	
Temporary Traffic Control							
Paint	15	N/A	X	X	X	X	See Chapter 2-500.00

Notes:

1. For projects using an Open-Graded Friction Course (OGFC) for the surface layer, only Enhanced Flatline Thermoplastic (Item No 716-12.02) may be used for the edge, center, skip and lane lines. Use the width of line specified in Table 2-3B. The Designer shall footnote the Enhanced Flatline Thermoplastic Quantity with the following note: *“Contractor shall use the extruded or ribbon method for application.”*
2. Specialty Striping Items: stop lines, cross walks, arrows, words, shapes, channelization, and other specialty striping items other than lane and edge lines. The contractor may elect to use either thermoplastic or preformed thermoplastic for specialty striping items.

**Table 2-3A
Permanent Pavement Markings Selection Guide Base on Pavement Type**

**TDOT ROADWAY DESIGN GUIDELINES – PDN
CHAPTER 2 GEOMETRIC DESIGN CRITERIA**

English

Revised:

Roadway Functional Classification		Permanent Pavement Markings		Snowplowable Raised Pavement Markers		Rumble Strip and Rumble Stripe							
		100 mils Extruded or Ribbon Thermoplastic with Type I & IV bead Package 716-12.02 6" Enhanced Flatline Thermoplastic	100 mils Extruded or Ribbon Thermoplastic with Type I & IV bead Package 716-12.09 12" Enhanced Flatline Thermoplastic Or 716-02.07 Plastic Pavement Marking 24" Barrier Line	60 mils Spray Thermoplastic with Type I bead Package 716-13.02 6" Spray Thermoplastic	15 mil Painted Pavement Marking 716-05.01 4" Painted Pavement Marking	716-01.21 SRPM (Bi-Dir) (1-color, 2-sides)	716-01.22 SRPM (Mono-Dir)	716-01.23 SRPM (Bi-Dir) (2-colors, 2-sided)	411-12-01 16" Rumble Strip	411-12.03 8" Rumble Stripe	411-12.04 4" Rumble Stripe	411-12.05 CL Rumble Stripe	
Roadway Functional Classification	Freeways or Divided State Route	Edge Lines	X Note 3						X Note 2				
		HOV Lane Lines		X Note 4					X Note 1				
		Dotted Lines Note 5	X Note 3										
		Gore Marking		X Note 4					X Notes 1, 4				
		Lane Lines	X Note 3					X Note 1	X Note 1				
	Undivided State Route Urban	Center line	X Note 3				X Note 1						
		Edge Lines	X Note 3				X Note 1						
		Lane Lines	X Note 3					X Note 1					
		Dotted Lines Note 5	X Note 3										
	Undivided State Route Rural	Center Line	X Note 3				X Note 1						Note 2
		Edge Lines Shoulder ≥8'	X Note 3							X Note 2			
		Edge Lines Shoulder 2' < 8'	X Note 3								X Note 2		
		Edge Lines Shoulder ≤ 2'	X Note 3									X Note 2	
		Lane Lines	X Note 3										
	Local Roads and streets ADT ≥ 2000	All Lines Notes 6, 7, & 8	X		X								
Local Roads ADT < 2000	All Lines Note 7 & 8				X								

**Table 2-3B
Permanent Pavement Markings, Raised Pavement Markers,
Rumble Strip and Rumble Stripe Guidelines Notes**

TDOT ROADWAY DESIGN GUIDELINES – PDN
CHAPTER 2 GEOMETRIC DESIGN CRITERIA

English

Revised:

Notes:

1. Snowplowable Raised Pavement Markers (SRPMs) shall conform to this guidance:
 1. SRPMs located along centerlines of 2 direction roadways (Yellow Stripe) shall be paid for under Item No. 716-01.21 “Snowplowable Raised Pavement Markers (Bi-Dir) (1-Color)” per each. Lenses shall be yellow.
 2. SRPMs on lane lines between lanes of the same travel (Broken White Stripes) direction on undivided roadways shall be paid under Item No. 716-01.22, “Snowplowable Raised Pavement Markers (Mono-Dir) (1-Color)” per each. Lenses shall be clear or white.
 3. SRPMs on lane lines between lanes of the same travel (Broken White Stripes) direction on divided roadways shall be paid for under Item No. 716-01.23, “Snowplowable Raised Pavement Markers (Bi-Dir) (2-Color)” per each. Lenses shall be clear or white on the upstream side (facing traffic), lenses shall be red facing downstream side (facing wrong-way traffic).
 4. Refer to T-M-series standard drawings for details. Three lane and multilane roads with 2-way traffic will normally require both mono-directional and bi-directional snowplowable raised pavement markers. Two lane roads will normally require bi-directional snowplowable raised pavement markers.
 5. Payment for the removal of Snowplowable Raised Pavement Markers shall be paid for under Item number 716-01.30 (Removal of Snowplowable Reflective Marker, per each). The cost shall not be included in the cost of installing the following items for Snowplowable Reflective Marker: 716-01.21, 716-01.22, and 716-01.23.
 6. Installation of SRPMs may be optional at undivided rural state routes with speed < 45 mph if historical crash data supports lane departure concerns.
2. Rumble Strip/Stripe
 1. All resurfacing projects shall follow the guidance in Table 2-3B for pavement marking and rumble installations. See 2-504.00 and 2-505.00 for additional guidance regarding rumble strip and rumble stripe placement. Application of rumble shall be included on all rural roadway resurfacing projects if there is no existing rumble on the shoulder. Pavement markings and rumble strips/stripes shall be applied to the roadway surface after it has been scraped clean of overgrown vegetation and swept of loose debris.
 2. Rumble strips are not required on ramps.
 3. If a bike lane is proposed on a shoulder, only non-continuous rumble shall be used. See Standard Drawings MM-PM-2, T-M-15A and T-M-16.

TDOT ROADWAY DESIGN GUIDELINES – PDN
CHAPTER 2 GEOMETRIC DESIGN CRITERIA

English

Revised:

4. Centerline Rumble Stripes (See T-M-16A) may only be used if justified by crash history and if the road meets the following conditions:
 - i. Design Speed of 45 mph or greater
 - ii. ADT of 2000 or greater
 - iii. Lane width of 12 feet or greater
 - iv. Undivided Section
 - v. No passing or one-way passing zone
5. For concrete shoulders, the rumble strip is to be placed in accordance with standard drawings RP-CS-1 or RP-CS-2. Item No. 501-03.10, Concrete Shoulder Rumble Strip, L.F. The length of scoring shall be measured as the actual length of pavement scored.
6. Freeways and divided highways, See STD DWG T-M-15
Undivided state routes, See STD DWG T-M-15A, STD DWG T-M-16, and 16A
7. The Designer or the Field Engineer may choose to alternate rumble with profile thermoplastic pavement marking (per SP716PTA) when the following conditions exist:
 - i. On roadways with rigid pavement shoulders, when it is not practical or desirable to install ground-in rumble on the inside and outside edge line pavement markings.
 - ii. On shoulder pavement types, Micro surface and Thin lift.
 - iii. On bridge decks without an asphalt layer.
3. Specialty Pavement Marking Materials: Polyurea, Profile Thermoplastic, and Tape. The Designer may choose to use one of the specialty pavement marking material as needed.
4. Use applicable standard drawings:
 1. Freeways, See STD DWG T-M-5, T-M-6, T-M-7, and T-M-8
 2. State Route, See STD DWG T-M-1, T-M-2, and T-M-3
 3. HOV Lanes, See STD DWG T-M-5
 4. Gore Areas, See T-M-6, SRPM along edge line only.
5. Dotted Lines and Dotted Line Extensions shall be utilized when called out on the Standard Drawings. See Standard Drawings T-M-4, 5, 6, and 8.

TDOT ROADWAY DESIGN GUIDELINES – PDN
CHAPTER 2 GEOMETRIC DESIGN CRITERIA

English

Revised:

6. On Local Roads with the ADT \geq 2000, permanent pavement markings may be Item Number 716-13.02 Spray Thermo Pavement Marking (60 mil 6 IN) per L.M. or Item Number 716-12.02 Enhanced Flatline Thermoplastic Pavement Marking (6 IN) per L.M.
7. For non-State Route Local Roads with ADT < 2000, no permanent striping is required on the final surface if Item Number 716-05.01 Painted Pavement Marking (15 mil 4 IN) is used as the temporary striping for the final layer.
8. Low cost resurfacing treatments may have modified marking recommendations.

2-503.00 RUMBLE STRIPS

Rumble **strips** are an effective countermeasure for reducing roadway departure crashes. The noise and vibration produced by rumble strips alert drivers when they leave the traveled way.

The scored rumble strip shall be constructed in accordance with Standard Drawing T-M-15. Rumble strips are to be paid for under Item No. 411-12.01 Scoring Shoulders (Continuous) (16 inch Width) per L.M. For estimating purposes, the item will be measured longitudinally along the edge of each shoulder and will usually be two (2) times the project length less deductions for entrance and exit ramps, public roads, and bridges.

Refer to [Chapter 2-502.00, Permanent Pavement Markings](#), for guidelines for placement of rumble strips on non-access-controlled state routes. When rumble strips are placed on non-access-controlled routes, paved shoulders should be 8 ft. or wider. A 60-foot rumble will be followed by a 15-foot gap in the rumble to allow for bicycles to cross without having to traverse the rumble strip. Rumble strips should normally be placed on rural routes with posted speeds of 45 mph or greater. Rumble strips may be used on urban routes where crash history or other factors warrant the placement. When placed on urban routes, the Designer should consider expected bicycle traffic and noise generated. Alternatively, mumble stripes may be used on urban routes to mitigate external noise. Scored rumble strip shall be constructed in accordance with Standard Drawing T-M-15A. Rumble strips are to be paid for under Item No. 411-12.02 Scoring Shoulders (Non-continuous) (16 inch Width) per L.M. The item will be measured and paid as the actual length of pavement scored along each shoulder.

Typically rumble strips reduce run-off-the-road crashes, which includes rollover and fixed-object crashes. Shoulder rumble strips are 16” wide scored strips placed as a countermeasure to assist drivers who may unintentionally drift over the edge line. Rumble strips shall be specified on all new construction and resurfacing projects on freeways and access-controlled facilities. Both the inside and the outside shoulders shall be scored. Typically, rumble strips are applied on freeways and access-controlled facilities 16” wide at a 12” offset from the edge line.

TDOT ROADWAY DESIGN GUIDELINES – PDN
CHAPTER 2 GEOMETRIC DESIGN CRITERIA

English

Revised:

2-503.01 TYPES OF RUMBLE STRIPS

1. SCORED SHOULDER RUMBLE STRIPS

Scored rumble strips and scored rumble stripes provide an audible warning to vehicles leaving the travel lane. Unlike a scored rumble stripe which is placed at the edge line location, a scored rumble strip is placed on the shoulder adjacent to the travel lane and edge line. Shoulder rumble strips should be omitted on concrete bridge decks, adjacent to ramps, acceleration and deceleration lanes.

Based on pavement type the application of rumble strips varies as follows:

A. Flexible pavement

Install new paved shoulder rumble strips per Standard Drawings T-M- 15 and 15A. It is recommended to seal the scored strip on OGFC. Shoulder rumble strips on thin lift should be limited to the depth of 1/4" per Standard Drawing T-M-16A. Do not remove more than 50% of new pavement depth during scoring. Alternatively, raised or inverted profiled thermoplastic pavement marking may be installed. Shoulder rumble strips on chip seal is not recommended. Application of fog seal over the existing rumble does not affect the performance.

B. Rigid Pavement

There are two alternatives available to install rigid pavement rumbles: stamped or scored.

Install stamped concrete shoulder per Standard Drawing RP-CS-1 and scored concrete shoulder per RP-CS-2.

Rumble strips on concrete shoulders shall be paid for under Item No. 501-03.10 Concrete Shoulder Rumble Strips per L.F. The item will be measured as the actual length of pavement scored along each shoulder.

2. RAISED RUMBLE STRIPS

Transverse rumble strips

They are used to alert drivers for a need to slow down or stop, or to other upcoming changes that may not be anticipated by an inattentive driver. These rumble strips are placed in the travel lane perpendicular to the direction of travel per Standard Drawing T-WZ-56. Typical locations for these rumble strips are on approaches to intersections, toll plazas, horizontal curves and work zones.

B. Transverse raised bituminous rumble Strips

Raised bituminous rumble strips are a traffic warning device, and when required, shall be constructed installed in accordance with Standard Drawing T-WZ-56. Raised bituminous rumble strips will require a detail to be furnished in the plans. This type of rumble strip is to be used for warning or unexpected stop conditions and shall not be used routinely as a shoulder treatment. The raised bituminous rumble strip may be

TDOT ROADWAY DESIGN GUIDELINES – PDN
CHAPTER 2 GEOMETRIC DESIGN CRITERIA

English

Revised:

used to warn the motoring public at approaches to T-intersections or narrow bridges. They should not be used in urban residential zones without engineering justification.

For more information refer to [FHWA Technical Advisory T 5040.39: Shoulder and Edge Line Rumble Strips](#) for use and information on the purpose and effectiveness of shoulder and edge line rumble strips. Additionally, it provides application considerations, design and installation information, suggestions for mitigating adverse effects and public outreach.

2-504.00 RUMBLE STRIPES

Rumble **stripes** is the term used for rumble strips painted with a retroreflective pavement marking to increase the visibility of the pavement edge at night and during inclement weather conditions.

1. SCORED EDGE LINE RUMBLE STRIPES

They are an effective means of reducing run-off-the-road crashes. They are primarily used to warn drivers when they have drifted from their lane. Edge line rumble stripes are a variation on shoulder rumble strips. The pavement markings are placed within the rumble strip, improving the visibility of the marking. Typically rumble stripes are applied on two or four lane rural highways with variable shoulder widths.

Scored Edge line rumble stripes should be omitted adjacent to tapers and along the radius of side road approaches, entrances and median crossovers. However, they are recommended at lane reduction taper sections. Edge line rumble stripes may be applied 4" or 8" wide with skip to minimize impacts to the other road users such as bike. Like rumble strips, edge line rumble stripes may be applied at 1/4" deep with thin lift pavement or 3/8" as a standard depth per Standard Drawing T-M-16A.

2. RAISED EDGE LINE RUMBLE STRIPES

Raised edge line rumble stripes should be installed using raised or inverted profiled thermoplastic pavement marking. This treatment provides a rumble effect and enhances visibility compared with standard lane markings, particularly at night and during wet conditions. This treatment may be installed at locations where flexible pavement depth is too shallow to install scored edge line rumble stripes. However, due to the material cost, only locations that justify the safety benefit may receive the treatment. Also, the treatment would be limited to areas where there is little or no snow because snowplow blades will easily scrape off the markings.

3. SCORED CENTER LINE RUMBLE STRIPES

Scored center line rumble stripes are an effective countermeasure to reduce head-on collisions and opposite-direction sideswipes (often referred to as cross-over or cross-center line crashes). Center line rumble strips are primarily used to warn drivers whose vehicles are crossing center lines of two-lane, two-way roads at no passing zones. Center line rumble strips shall be

TDOT ROADWAY DESIGN GUIDELINES – PDN
CHAPTER 2 GEOMETRIC DESIGN CRITERIA

English

Revised:

installed per Standard Drawing T-M-16A and are to be paid for under Item No. 411-12.04 Scoring for Rumble Stripe (Non-Continuous) (4IN Width), per L.M. by doubling the quantity and having a description, “CONTINUOUS”. Center line rumble stripes should be omitted adjacent to tapers and along the radius of side road approaches, entrances, and median crossovers.

For more information refer to, [FHWA Technical Advisory T 5040.40](#) for use and information on the purpose and effectiveness of center line rumble strips. Additionally, it provides application considerations, design and installation information, suggestions for mitigating adverse effects and public outreach.

2-505.00 MUMBLE STRIPES

Mumble stripes are similar to traditional rumble strips, but they have a wave pattern that is grounded into the pavement that lessens the external noise produced when vehicles travel across them. The sinusoidal mumble stripe pattern does lower roadside noise levels while maintaining interior cabin noise and vibration levels adequate to alert the driver. Therefore, they are the preferred alternative on roadways in urban zones. Reach out to the Engineering Production Support Division for more information.

2-506.00 SAFETY EDGE

A safety edge is a sloped (25 to 30 degree) asphalt edge that more easily allows vehicles that have run off the road to regain the roadway than a standard vertical face. The Designer should calculate the additional quantities needed for the pavement required for safety edges.

For resurfacing projects, a safety edge will be applied only when identified on the PS&E Report submitted by the Regional Resurfacing Coordinator. If the total existing drop off and any additional elevation difference from paving operations results in a drop off exceeding 1.75”, a safety edge should be used. See *Chapter 9-140.00, Pavement*, for note that shall be added to the plans on all projects that specify safety edge.

2-507.00 FLEXIBLE DELINEATORS

Flexible delineators will be installed on all freeway and access-controlled highways. Flexible delineators may also be used on other routes. On resurfacing projects (4R, etc.), the Designer will be responsible for computing the quantity of flexible delineators and shall refer to Roadway Standard Drawing T-WZ-PBR2 to calculate quantities. The Designer shall replace delineators along the ramps as well as along the main line on freeway and access-controlled highway resurfacing projects.

On projects with signing and marking plans, the location of the flexible delineators should be shown on the signing and marking plan sheets. If signing and marking plans are not included, the Designer does not need to show the location of the proposed delineators but must make sure

TDOT ROADWAY DESIGN GUIDELINES – PDN
CHAPTER 2 GEOMETRIC DESIGN CRITERIA

English

Revised:

Roadway Standard Drawing T-S-11 is included in the plans so the proper location can be determined by the engineer and contractor.

2-508.00 SPECIALTY PAVEMENT MARKINGS

Contractors will have the option of using either Thermoplastic or Preformed Plastic Pavement Markings specialty markings. For plan development and bidding purposes, Designers will use the appropriate Thermoplastic Pavement Marking items numbers. All specialty pavement marking item numbers shall be footnoted:

“Contractor may elect to substitute Preformed Plastic for Thermoplastic. Preformed Plastic shall be paid for at the same unit price as bid for Thermoplastic.”

On projects where plastic specialty pavement items are being used, the following items will be used:

1. Crosswalk with longitudinal lines as shown on Standard Drawing T-M-4 will use the following pay item:

716-02.09, Plastic Pavement Marking (Longitudinal Cross Walk) per L.F.

The measurement for this marking is identical to that for standard crosswalk, for example, one measurement along the centerline of the crosswalk (perpendicular to curbs).

2. Dotted white line for vehicle double turn path delineation requires an 8-inch stripe. Pay item will be as follows:

716-02.08, Plastic Pavement Marking (8" Dotted Line) per L.F.

2-509.00 USE OF REMOVABLE PAVEMENT MARKING LINE

Item No. 712-09.01, Removable Pavement Marking Line per L.F., shall be used as temporary marking for directional or separation of traffic during the traffic control phases of construction when these lines are used on a roadway surface that is to remain in place and undisturbed. Item No. 712-09.08, Removable Pavement Marking Line per L.F., shall be used for lane shifts as shown in T-WZ-16. When a barrier is in use, item no. 712-09.02, Removable Pavement Marking Line (8" Barrier Line) shall be used in that location as shown the Standard Drawing.

2-510.00 SNOWPLOWABLE RAISED PAVEMENT MARKERS

Snowplowable raised pavement markers shall be included on all freeway and full-access controlled roadways. See Table 2-3B for guidance.

Snowplowable raised pavement markers should be included on state routes with the exception of undivided state routes with speed < 45 mph. Reflective pavement markers are to be

TDOT ROADWAY DESIGN GUIDELINES – PDN
CHAPTER 2 GEOMETRIC DESIGN CRITERIA

English

Revised:

placed in accordance with the Roadway Standard Drawing T-M-series and the current edition of the MUTCD.

Spacing of snowplowable raised pavement markers may be reduced or additional snowplowable raised pavement markers added in areas that require special treatment as determined by the Design Manager or at the Functional Design Plans field review. When additional snowplowable raised pavement markers are used, the markers shall be placed in accordance with the current edition of the MUTCD. Raised pavement markers may be omitted on urban roadways where roadway lighting is present. Raised pavement markers should not be used on the right edge line. See Table 2-3B for guidance regarding type of markers to be used.

On freeway, full-access control, and state route resurfacing projects, the Resurfacing PS&E Team shall be responsible for verifying the existence of snowplowable raised pavement markers and for computing the quantity of these markers for removal. The Designer shall also compute the quantity for new snowplowable raised pavement markers to be installed for these projects.

SECTION 6 – INTERSECTIONS

2-600.00 INTERSECTIONS

Intersections are either at-grade (two roads meet and cross each other) or are grade-separated (i.e. an interchange). Intersections are either uncontrolled, controlled by traffic signals/signs, shared spaces (such as a roundabout), or are interchanges. Chapter 3, Multimodal Design, should be used to ensure that bicycle, pedestrian, and transit are considered in addition to roadway traffic at urban locations. The guidelines also ensure compliance with the Americans with Disabilities Act (ADA) and Public Rights-of-Way Accessibility Guidelines (PROWAG). For more information, please see the TDOT [Multimodal Project Scoping Manual](#).

2-601.00 LANE DROP AFTER INTERSECTION

Existing two-lane highways are often widened to a multi-lane section at intersections to provide additional capacity (especially at signalized locations). When this occurs, the lane may be dropped at the intersection, at a crossroad or may carry through and transition after the intersection.

In order to address the resulting lane drop situation, follow the schematic shown in *Figure 2-9, Minimum Length (X) for Lane Reduction Transition through an Intersection with a Lane Reduction Taper (L)*, which shows the minimum length for the additional through lanes required to adequately sign the lane drop and minimize lane changing within the intersection. Use *Table 2-4, Guidelines for Advance Placement of Warning Signs*, to help find the “d” value reflected in *Figure 2-9, Minimum Length (X) for Lane Reduction Transition through an Intersection with a Lane Reduction Taper (L)*. An example for computing the required transition lengths is also included with this figure.

TDOT ROADWAY DESIGN GUIDELINES – PDN
CHAPTER 2 GEOMETRIC DESIGN CRITERIA

English

Revised:

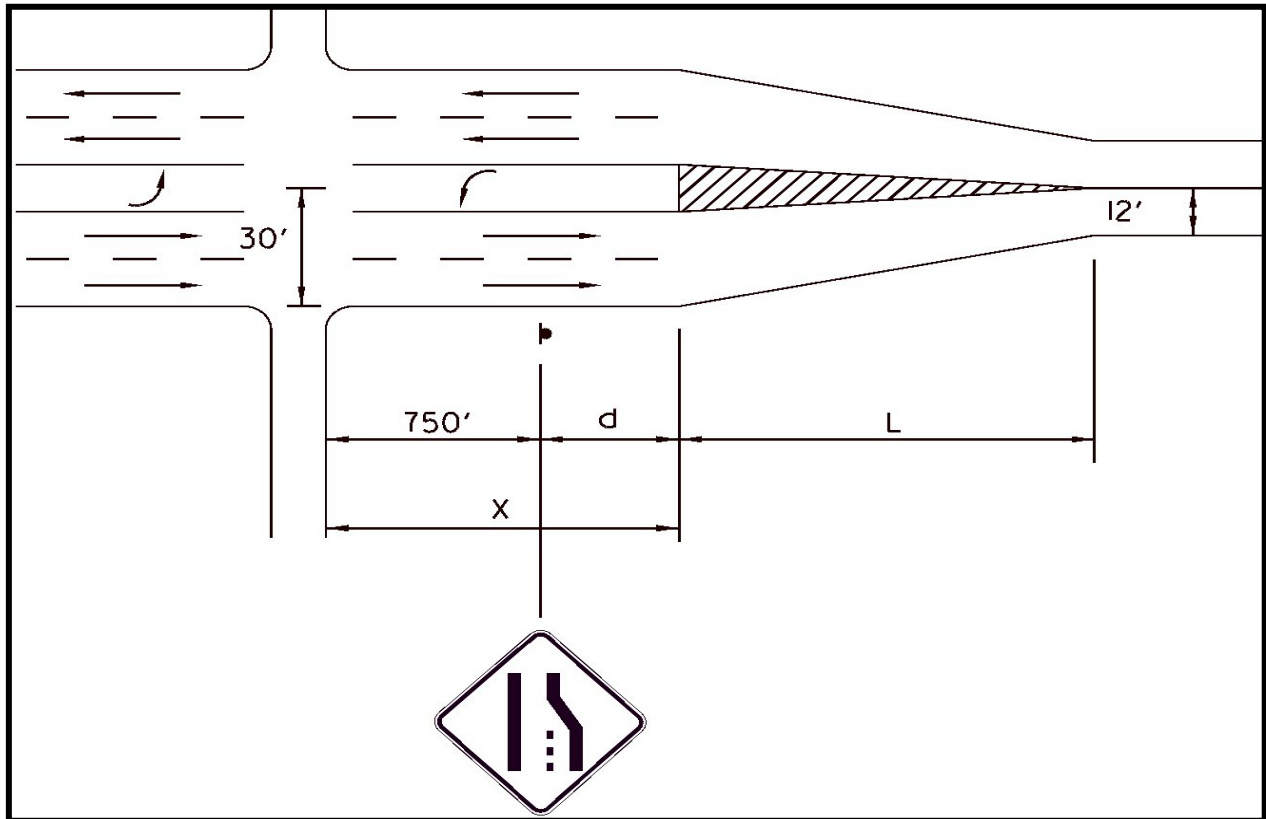

Figure 2-9

**Minimum Length (X) for Lane Reduction Transition through an Intersection
with a Lane Reduction Taper (L)**

$$L = (S^2 \times W) / 60 \text{ (for speed less than 45 mph)}$$

$$L = S \times W \text{ (for speed 45 mph or more)}$$

- 750 ft = Minimum distance at which sign is not visible to traffic approaching intersection (in order to minimize lane changing within intersection).
- X = Minimum length for lane reduction transition (ft)
- S = Speed (mph)
- W = Width of the offset distance (ft.)
- d = As required by *M.U.T.C.D.*, Sec. 2C.05, Table 2C-4, Condition A.
- L = Taper length, as required by *M.U.T.C.D.*, Sec. 3B.09, Fig. 3B-14.

Note 1: Terminating the outside lane as a right-turn lane at an intersection may be considered subject to the review and approval of the TDOT Signal Section and the Design Manager.

Note 2: See *M.U.T.C.D* Section 2C.42 for guidance, options, and standard use of Lane

TDOT ROADWAY DESIGN GUIDELINES – PDN
CHAPTER 2 GEOMETRIC DESIGN CRITERIA

English

Revised:

Ends Signs.
 To find “d” use the following table:

Posted or 85 th - Percentile Speed	Advance Placement Distance ¹								
	Condition A: Speed Reduction and lane changing in heavy traffic ²	Condition B: Deceleration to the listed Advisory Speed (mph) for the Condition							
		0 ³	10 ⁴	20 ⁴	30 ⁴	40 ⁴	50 ⁴	60 ⁴	70 ⁴
20 mph	225 ft	100 ft ⁶	N/A ⁵	-	-	-	-	-	-
25 mph	325 ft	100 ft ⁶	N/A ⁵	N/A ⁵	-	-	-	-	-
30 mph	460 ft	100 ft ⁶	N/A ⁵	N/A ⁵	-	-	-	-	-
35 mph	565 ft	100 ft ⁶	N/A ⁵	N/A ⁵	N/A ⁵	-	-	-	-
40 mph	670 ft	125 ft	100 ft ⁶	100 ft ⁶	N/A ⁵	-	-	-	-
45 mph	775 ft	175 ft	125 ft	100 ft ⁶	100 ft ⁶	N/A ⁵	-	-	-
50 mph	885 ft	250 ft	200 ft	175 ft	125 ft	100 ft ⁶	-	-	-
55 mph	990 ft	325 ft	275 ft	225 ft	200 ft	125 ft	N/A ⁵	-	-
60 mph	1,100 ft	400 ft	350 ft	325 ft	275 ft	200 ft	100 ft ⁶	-	-
65 mph	1,200 ft	475 ft	450 ft	400 ft	350 ft	275 ft	200 ft	100 ft ⁶	-
70 mph	1,250 ft	550 ft	525 ft	500 ft	450 ft	375 ft	275 ft	150 ft	-
75 mph	1,350 ft	650 ft	625 ft	600 ft	550 ft	475 ft	375 ft	250 ft	100 ft ⁶

Table 2-4
Guidelines for Advance Placement of Warning Signs

Reference: M.U.T.C.D. 2009 Manual (Table 2C-4 of Section C.05)

Notes:

¹The distances are adjusted for a sign legibility distance of 180 ft for Condition A. The distances for Condition B have been adjusted for a sign legibility distance of 250 feet, which is appropriate for an alignment warning symbol sign.

For Conditions A and B, warning signs with less than 6-inch legend or more than four words, a minimum of 100 feet should be added to the advance placement distance to provide adequate legibility of the warning sign.

²Typical conditions are locations where the road user must use extra time to adjust speed and

TDOT ROADWAY DESIGN GUIDELINES – PDN
CHAPTER 2 GEOMETRIC DESIGN CRITERIA

English

Revised:

change lanes in heavy traffic because of a complex driving situation. Typical signs are Merge and Right Lane Ends. The distances are determined by providing the driver a PRT of 14.0 to 14.5 seconds for vehicle maneuvers (2005 AASHTO Policy, Exhibit 3-3, Decision Sight Distance, Avoidance Maneuver E) minus the legibility distance of 180 feet for the appropriate sign.

³Typical condition is the warning of a potential stop situation. Typical signs are Stop Ahead, Yield Ahead, Signal Ahead, and Intersection Warning signs. The distances are based on the 2005 AASHTO Policy, Exhibit 3-1, Stopping Sight Distance, providing a PRT of 2.5 seconds, a deceleration rate of 11.2 feet/second², minus the sign legibility distance of 180 feet.

⁴Typical conditions are locations where the road user must decrease speed to maneuver through the warned condition. Typical signs are Turn, Curve, Reverse Turn, or Reverse Curve. The distance is determined by providing a 2.5 second PRT, a vehicle deceleration rate of 10 feet/second², minus the sign legibility distance of 250 ft.

⁵No suggested distances are provided for these speeds, as the placement location is dependent on site conditions and other signing. An alignment warning sign may be placed anywhere from the point of curvature up to 100 feet in advance of the curve. However, the alignment warning sign should be installed in advance of the curve and at least 100 feet from any other signs.

⁶The minimum advance placement distance is listed as 100 feet to provide adequate spacing between signs.

EXAMPLE:

For Condition A: Speed Reduction and Lane Changing in Heavy Traffic:

Posted speed = 55 mph

$X = 750 \text{ feet} + d = 750 \text{ feet} + 990 \text{ feet} = 1,740 \text{ feet}$

$L = S \times W \text{ (for speed 45 mph or more)} = 55 \times 18 = 990 \text{ feet}$

Where:

L = Taper Length (ft)

S = Posted speed (55 mph)

W= Transition Width (30 feet – 12 feet = 18 feet)

For Condition B: Deceleration from Posted speed of 45mph to speed of 30 mph:

$X = 750 \text{ feet} + d = 750 \text{ feet} + 100 \text{ feet} = 850 \text{ feet}$

$L = \frac{WS^2}{60} \text{ (for speed less than 45 mph)} = L = \frac{18 \times 45^2}{60} = 607.5 \text{ ft}$

Where:

L = Taper Length (ft)

TDOT ROADWAY DESIGN GUIDELINES – PDN
CHAPTER 2 GEOMETRIC DESIGN CRITERIA

English

Revised:

S = Posted speed (45 mph)

W= Transition Width (30 feet – 12 feet = 18 feet)

2-602.00 TURNING LANES AT INTERSECTIONS

Left and right turn lanes are added at intersections to increase capacity and improve safety and traffic flow.

The following guidelines are applicable to right and left-turn lanes and give procedures for desirable design. Design may be limited by geometric or other constraints, but these guidelines shall be followed as closely as possible. *Figure 2-10, Turning Lane Terminology*, shows the terminology for turning lanes.

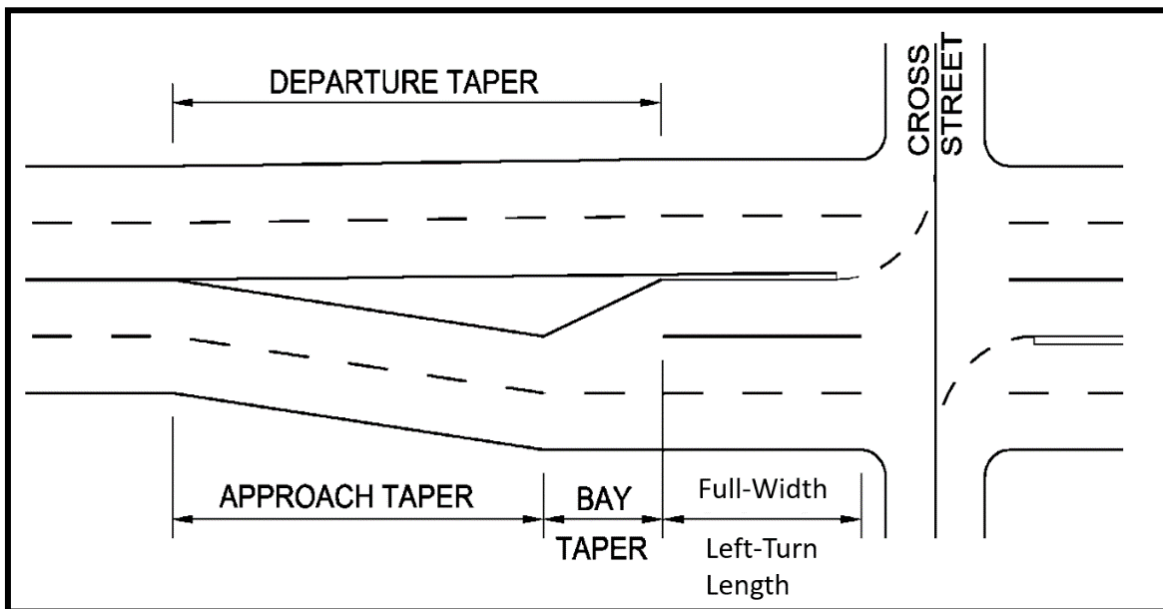

Figure 2-10
Turning Lane Terminology

1) APPROACH TAPER

(a) $L = W \times S$, Speed \geq 45 mph

(b) $L = \frac{WS^2}{60}$, Speed < 45 mph

Where: L = Length of Taper in feet
W = Width of Offset in feet;
S = Design Speed in miles per hour

TDOT ROADWAY DESIGN GUIDELINES – PDN
CHAPTER 2 GEOMETRIC DESIGN CRITERIA

English

Revised:

2) BAY TAPER

$L = \frac{WS}{3}$, L, W, S as defined for approach taper above.

3) FULL-WIDTH LEFT-TURN LANE WIDTH

Refer to TDOT Highway Systems Access Manual, Volume 3 for turn lane warrants and guidance on turn lane sizing.

4) DEPARTURE TAPER

The departure taper begins at the end of the bay taper and ends at the beginning of the approach taper and cannot exceed the approach taper rate criteria.

2-603.00 J-TURN INTERSECTIONS

A J-turn intersection is an intersection that prevents direct crossing and left-turn movements from the minor approach roadway. This is a variation of the restricted crossing u-turn (RCUT). It is often used in areas where the crash rate is high due to motorists attempting to cross a median into oncoming traffic traveling at a high speed. *Figure 2-11, J Turn in Maury County, TN*, is a J-turn located on Canaan Road and US 43/SR 6 in Mt. Pleasant, Maury County, TN. This J-turn was constructed because there were several crashes at the intersection with over 50% involving right angle collisions and a posted speed of 55 mph. From the figure, the J-turn requires side road movements to be made indirectly by making a right turn into traffic (move 1) (opposite than the direction they want to travel), traveling about a quarter-mile on the divided main road (moves 2-3-4), turning left into the median (move 5), proceeding to the J-Turn area (move 6) until it is safe to proceed into traffic (move 7) in the original direction they want to go. Refer to TDOT Highway Systems Access Manual, Volume 3 for design guidance of J-turn intersection and other U-turn dependent designs.



Figure 2-11
J Turn in Maury County, TN (Not to Scale)

2-604.00 INTERSECTIONS LOCATED NEAR THE LIMITS OF CONSTRUCTION

On new construction or reconstruction projects when an intersection is located at the beginning or end limit of construction the project shall comply with the following:

- A. If design of the intersection is included in the scope of the project defined by the technical report, the Designer shall include the entire intersection (i.e. place the construction limit at a point beyond the stop bar on the far side of the intersection from the project.) **This includes installing updates to ensure all ADA and PROWAG measures are met.**
- B. If design of the intersection is not included in the scope of the work defined by the Concept Report, the Designer shall exclude the entire intersection (i.e. place the construction limit at a point no closer than the stop bar on the near side of the intersection from the project).
- C. In no case shall the Designer place the construction limits between the stop bars of a signalized intersection.

SECTION 7 – INTERCHANGES

2-700.00 INTERCHANGES

There are several types of interchanges including diamond, directional, cloverleaf, single point urban interchanges (SPUI), and diverging diamonds. Information on Interchanges can be found in *A Policy of Geometric Design of Highways and Streets*, Chapter 10, AASHTO, 2018. See *Figure 2-12, Types of Interchanges*.

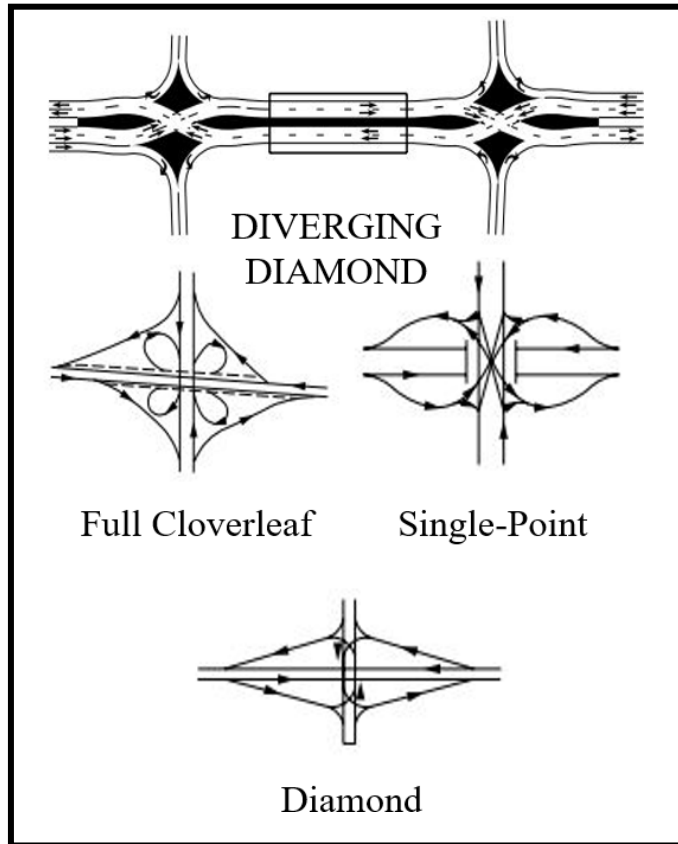

Figure 2-12 Types of Interchanges

TDOT ROADWAY DESIGN GUIDELINES – PDN
CHAPTER 2 GEOMETRIC DESIGN CRITERIA

English

Revised:

2-700.01 INTERCHANGE RAMP DESIGN

A ramp is used to connect two or more legs at an interchange. They are composed of a terminal at each leg and a connecting road. See *A Policy of Geometric Design of Highways and Streets*, Section 10.9.6.1, AASHTO, 2018 for more information. See *Figure 2-13, Common Ramp Types*.

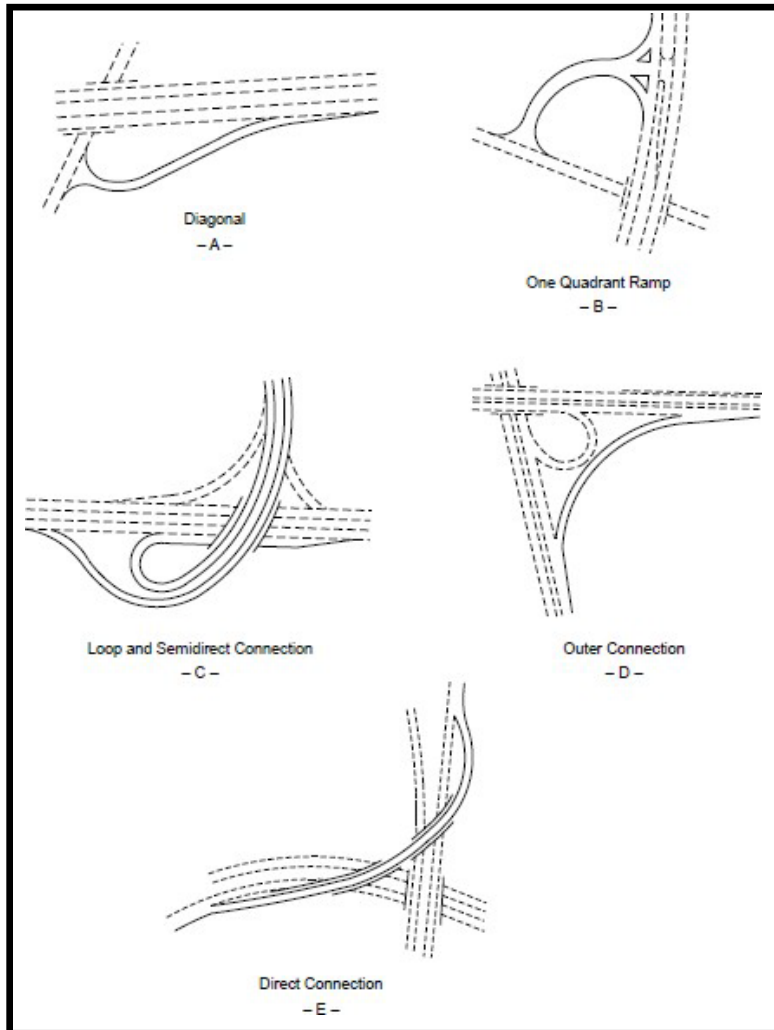

Figure 2-13
Common Ramp Types

2-700.02 TWO-LANE ENTRANCE RAMPS ON FREEWAYS AND EXPRESSWAYS

Designers shall use the parallel design when introducing two-lane entrance ramps to freeways and expressways. Parallel ramps are preferred on both single and multi-lane ramps.

The parallel design is preferable for two reasons: (1) past experience with the tapered

TDOT ROADWAY DESIGN GUIDELINES – PDN
CHAPTER 2 GEOMETRIC DESIGN CRITERIA

English

Revised:

design has been undesirable from an operational and safety standpoint; (2) uniformity of design due to the fact that most two-lane entrance ramps statewide are the parallel type.

For examples of the parallel design for two-lane entrance ramps, refer to *A Policy on Geometric Design of Highways and Streets*, AASHTO, 2018, Figure 10-76 and Figure 10-77.

2-700.03 ACCESS CONTROL AT INTERCHANGE RAMPS

Refer to TDOT Highway Systems Access Manual, Volume 3 for spacing requirements of across points near interchange ramps.

Refer to the [AASHTO Highway Safety Manual](#) and the [Interstate System Access Informational Guide](#) for additional guidance on access control at interchange ramps.

SECTION 8 – MEDIANS

2-800.00 MEDIANS

Safety and improved traffic operations dictate the need for providing roadways with medians in the State of Tennessee. Both flush and depressed median widths and other general median principles are shown in the RD11-TS series - Typical Sections and Design Criteria section of the Roadway Standard Drawings and discussed in TDOT Highway Systems Access Manual, Volume 3. Due to safety concerns, many median divided roadways are access controlled and do not allow an opening for every private drive.

2-800.01 MEDIAN OPENING SPACING

Refer to TDOT Highway Systems Access Manual, Volume 3 for median opening spacing requirements.

2-800.02 MEDIAN OPENING SPACING - EXAMPLES

Refer to the [Median Opening Spacing Guide](#) for example problems detailing the procedure to be used in determining the appropriate median opening spacing.

2-800.03 LEFT TURN LANES IN MEDIANS

As discussed in *A Policy of Geometric Design of Highways and Streets*, Chapter 9, it is desirable to align left-turn lanes in medians – see *Figure 2-14, Left-Turn Lane Alignment*. The advantages of this placement are:

- a) Better visibility of opposing through traffic as left turners look for gaps.
- b) Decreased conflict between opposing left-turn vehicle paths.
- c) Increased numbers of left-turn vehicles served in a given period of time. The farther left the turn lane, the shorter the crossing distance for left-turn vehicles, allowing drivers to choose shorter gaps in opposing traffic and clear the intersection. There is also an increase in capacity at signalized intersections, due to more flexibility in left-turn phasing and shorter clearance intervals.

The following guidelines apply to four-lane divided roadways with a maximum median width of 48 feet. For medians greater than 48 feet, designers should offset left turn lanes to reduce the length required for the left turn onto an intersecting road.

The centerline of left-turn lanes shall be placed along the centerline of the median, so that opposing left-turn lanes are directly opposite each other. Excess pavement area between the turn

TDOT ROADWAY DESIGN GUIDELINES – PDN
CHAPTER 2 GEOMETRIC DESIGN CRITERIA

English

Revised:

lane and adjacent through lane shall be marked with channelization striping (see *Figure 2-14, Left-Turn Lane Alignment*)

For future traffic signal warrants, see Chapter 4 in the TDOT Traffic Design Manual and use the Hourly Percentages.

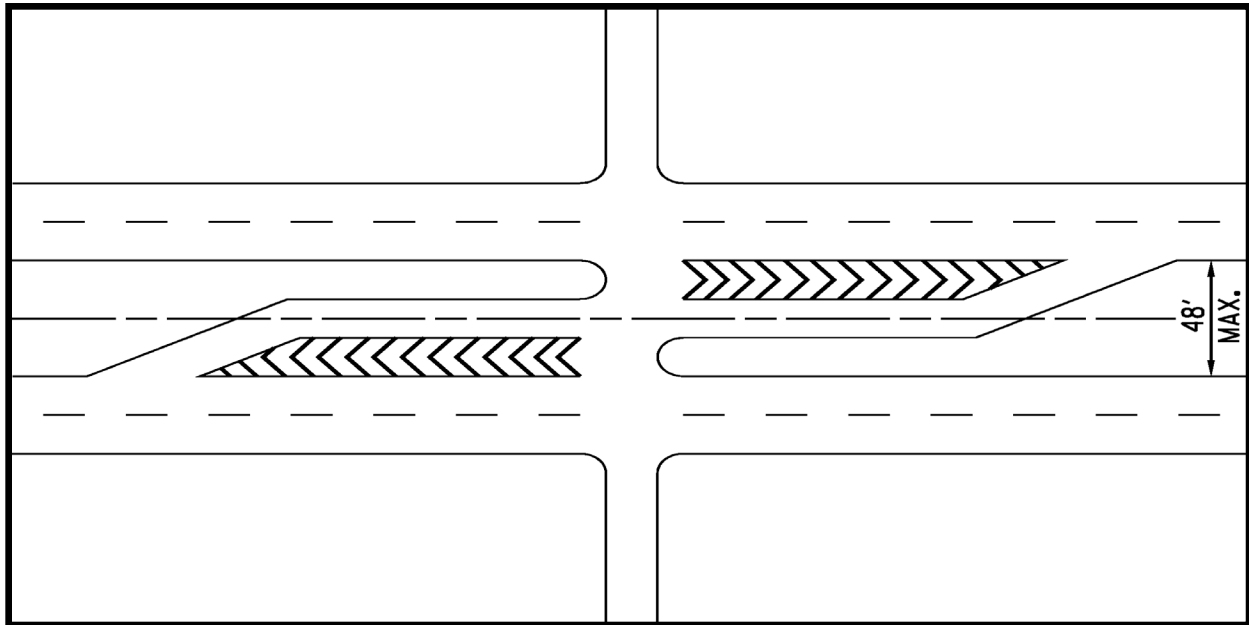

Figure 2-14
Left-Turn Lane Alignment

SECTION 9 – RETAINING WALL DESIGN

2-900.00 RETAINING WALLS

During the development of many roadway design projects, a retaining wall is proposed due to right-of-way limitations, environmental impacts, drainage issues, or the need to reduce damage to adjacent properties. The development of a retaining wall involves TDOT personnel including Project Development, Structures, and the Geotechnical Engineering Section of the Materials and Tests Division. A consultant may also serve as the Designer in place of Project Development and/or Structures personnel. When biological, environmental, hazardous materials, historical, or archeological factors are involved, it shall be necessary to coordinate with the Environmental Division to ensure the affected area is properly identified and protected.

The following sections will define the role each TDOT Division has in designing retaining walls, the steps needed to create retaining wall sheets, and which sheets are mandatory for field reviews and plan submittals.

2-900.01 RETAINING WALL SHEET NAMES, NUMBER, AND ORDER IN PLANS

All Retaining Wall Detail Sheets shall be designated as an “R” series. Refer to Chapter One of the Roadway Design Guidelines for information on the correct placement of the sheets in the index and plan sets for Functional, Plan-in-Hand, and PS&E Projects.

NOTE: Sheets with retaining wall information shall no longer be part of the Roadway “2” series sheets in construction plans.

The following series of sheets shall be used for each retaining wall:

1. Retaining Wall (R)
The sheet title block shall be named: Retaining Wall Estimated Quantities
The sheet number will be *R.sht, RA.sht, RB.sht, etc.*
These sheet(s) shall be provided by the Structures Division and Geotechnical Engineering Section and include the quantities for all retaining walls.
2. Retaining Wall (R#)
The sheet title block shall be named: Retaining Wall (R#) Geotechnical Design Notes and Requirements
The sheet number will be *R1.sht, R2.sht, R3.sht, etc.*

**TDOT ROADWAY DESIGN GUIDELINES – PDN
CHAPTER 2 GEOMETRIC DESIGN CRITERIA**

English

Revised:

These sheet(s) shall be provided by the Structure Division and Geotechnical Engineering Section.

3. Retaining Wall (R#A)

The sheet title block shall be named: Retaining Wall (R#A) Geometric Layout
The sheet number will be *R1A.sht, R2A.sht, R3A.sht, etc.*

These sheet(s) shall be provided by the Designer.

4. Retaining Wall (R#B)

The sheet title block shall be named: Retaining Wall (R#B) Soil Profiles and Details
The sheet number will be *R1B.sht, R2B.sht, R3B.sht, etc.*

These sheet(s) shall be provided by the Structures Division and Geotechnical Engineering Section.

If additional sheets are needed, the following naming format will be used:

5. Retaining Wall (R#C, R#D, etc.)

If there is additional information needed for a wall that falls outside the normal sheet titles as shown in previous numbers 1-4, this sheet series can be used and named as needed by Structures or Geotechnical.

The sheet title block shall be named: Retaining Wall (R#C) XXXXXXXX

The sheet number will be *R1C.sht, R2C.sht, R3C.sht, etc.*

These sheet(s) shall be provided by the Structures Division and Geotechnical Engineering Section.

The following is an example of the retaining wall portion of the R.O.W. Index for a project with three retaining walls where the additional sheet (R#C) was not needed.

RETAINING WALL DETAILS R1-R3B

The order of sheets in the plans shall be the following:

R1, R1A, R1B, R2, R2A, R2B, R3, R3A, and R3B.

The following is an example of the retaining wall portion of the Construction Index for a project with three retaining walls where the additional sheet (R#C) was not needed.

RETAINING WALL ESTIMATE AND DETAILS..... *R,R1-R3B

The order of sheets in the plans shall be the following:

*R, R1, R1A, R1B, R2, R2A, R2B, R3, R3A, and R3B.

TDOT ROADWAY DESIGN GUIDELINES – PDN
CHAPTER 2 GEOMETRIC DESIGN CRITERIA

English

Revised:

*Note that the Retaining Wall Estimates, sheet (R) is only in the construction plan set.

2-900.02 DEVELOP THE RETAINING WALL GEOMETRIC LAYOUT SHEET

During initial plans development, the Designer shall determine if a retaining wall shall be considered. When it is, **Steps 1- 4** shall be followed to develop the *Retaining Wall (R#A) Geometric Layout* sheet, often referred to as the conceptual drawing.

STEP 1: PREPARE THE PLAN, PROFILE, AND CROSS SECTION SHEETS

The following sheets in the roadway plans shall include the proposed retaining wall(s):

Present Layout Sheet: The Designer shall show the retaining wall on the present sheet. The station and offset for beginning, ending, and all breakpoints along the wall shall be labeled.

Proposed Layout Sheet: The Designer shall show the retaining wall on the proposed sheet. The station and offset for beginning, ending, and all breakpoints along the wall shall be labeled.

Profile Sheet: The Designer shall show a profile view of the top and bottom of the wall. The bottom of the wall shall be 2' below the ground line. The station and elevation for beginning, ending, and all breakpoints along the wall shall be labeled.

Cross Sections: The Designer shall display the centerline of the retaining wall in the cross sections. The Present R.O.W. limits and Proposed R.O.W. limits shall also be displayed onto the cross sections. For walls that are 100' or greater in length, cross sections shall be cut at the beginning and end stations of the wall, at **50'** station increments along the wall, and additional cross sections at 10' increments 50' prior to the beginning and 50' after the end of the wall. This will aid the Structures Division in determining the exact location of the beginning and ending stations of the wall. For retaining walls less than 100' in length, cross sections shall be cut at the beginning and end stations of the wall, at **10'** station increments along the wall, and additional cross sections at 10' increments 50' prior to the beginning and 50' after the end of the wall. These cross sections will be submitted in the **nnnnnn-nn-RetainingWall.zip** file but shall not be part of the R.O.W. or Construction .zip submittal. These cross sections shall remain in the Designer's files for information purposes only.

**TDOT ROADWAY DESIGN GUIDELINES – PDN
CHAPTER 2 GEOMETRIC DESIGN CRITERIA**

English

Revised:

STEP 2: PREPARE THE RETAINING WALL (R#A) GEOMETRIC LAYOUT SHEET

In addition to sheets in the roadway plans, a Retaining Wall Detail Geometric Layout Sheet, as shown in *Figure 2-15, Example Retaining Wall Detail Geometric Layout Sheet*, shall be developed by the Designer for each proposed retaining wall that includes the retaining wall Plan View, Profile View, and Typical Section details.

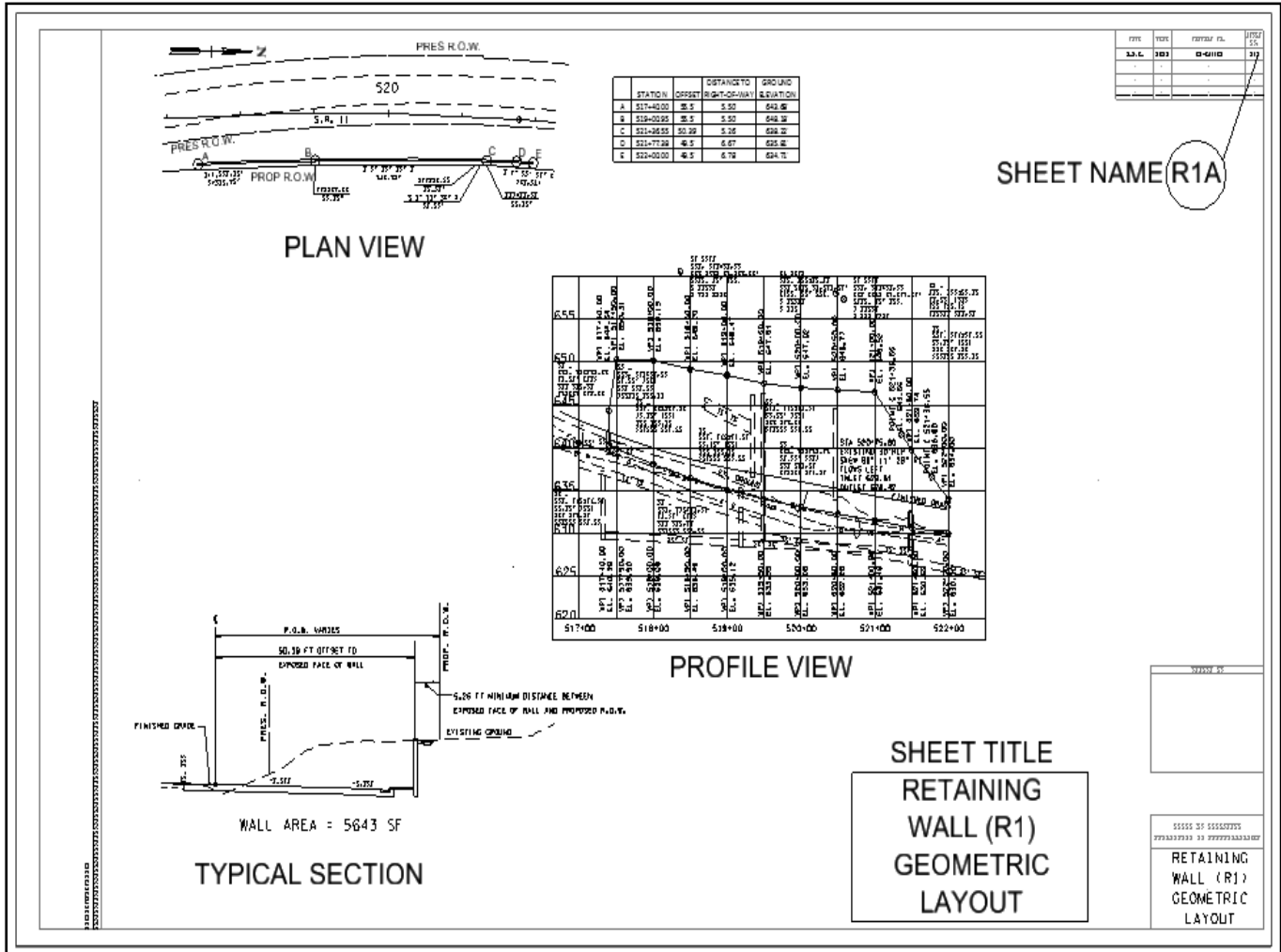

Figure 2-15

Example Retaining Wall Detail Geometric Layout Sheet

TDOT ROADWAY DESIGN GUIDELINES – PDN
CHAPTER 2 GEOMETRIC DESIGN CRITERIA

English

Revised:

Plan View: The Designer shall show the proposed layout of the retaining wall relative to the roadway centerline and Present and Proposed R.O.W. boundaries. All Proposed R.O.W. and/or easements shall be labeled. The layout shall show an alphabetical representation for the beginning, ending, and all breakpoints along the length of the wall. A chart shall be shown representing each of these points by stations based on the proposed centerline, offsets from proposed centerline to the exposed face of wall, distances between the exposed face of wall and Proposed R.O.W., and the ground elevations at the center of the wall. (Assume wall thickness is 1').

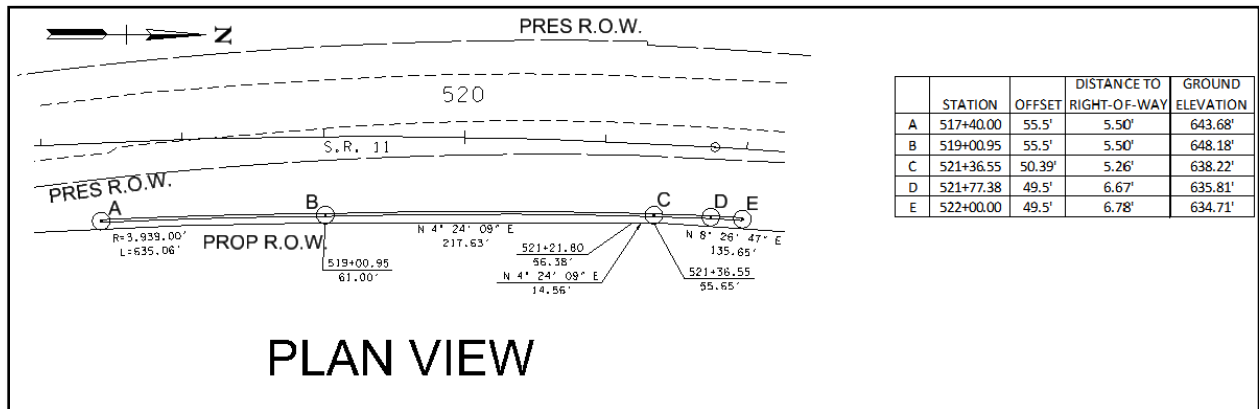

Figure 2-16
Example Retaining Wall Plan View

For clarity, the plan view used for the Retaining Wall (R#A) Geometric Layout Sheet shall not show any other features. The present and the proposed layout sheets shall have the retaining wall shown with additional features (existing and proposed utilities (if available), drainage structures, etc.).

Profile View: The Designer shall show a profile view of the top and bottom of the wall. The bottom of the wall shall be 2' below the ground line (this depth may change after review by the Structures Division). The stations and elevations for beginning, ending, and all breakpoints along the wall shall be labeled. The corresponding Points as shown in the Plan View shall also be shown in the profile. For this example, only Points C and D needed to be added. Because Point B at Sta. 519+00.95 was within 1' of the VPI at Sta. 519+00.00, the elevation was the same; thus, the point did not need to be labeled.

TDOT ROADWAY DESIGN GUIDELINES – PDN
CHAPTER 2 GEOMETRIC DESIGN CRITERIA

English

Revised:

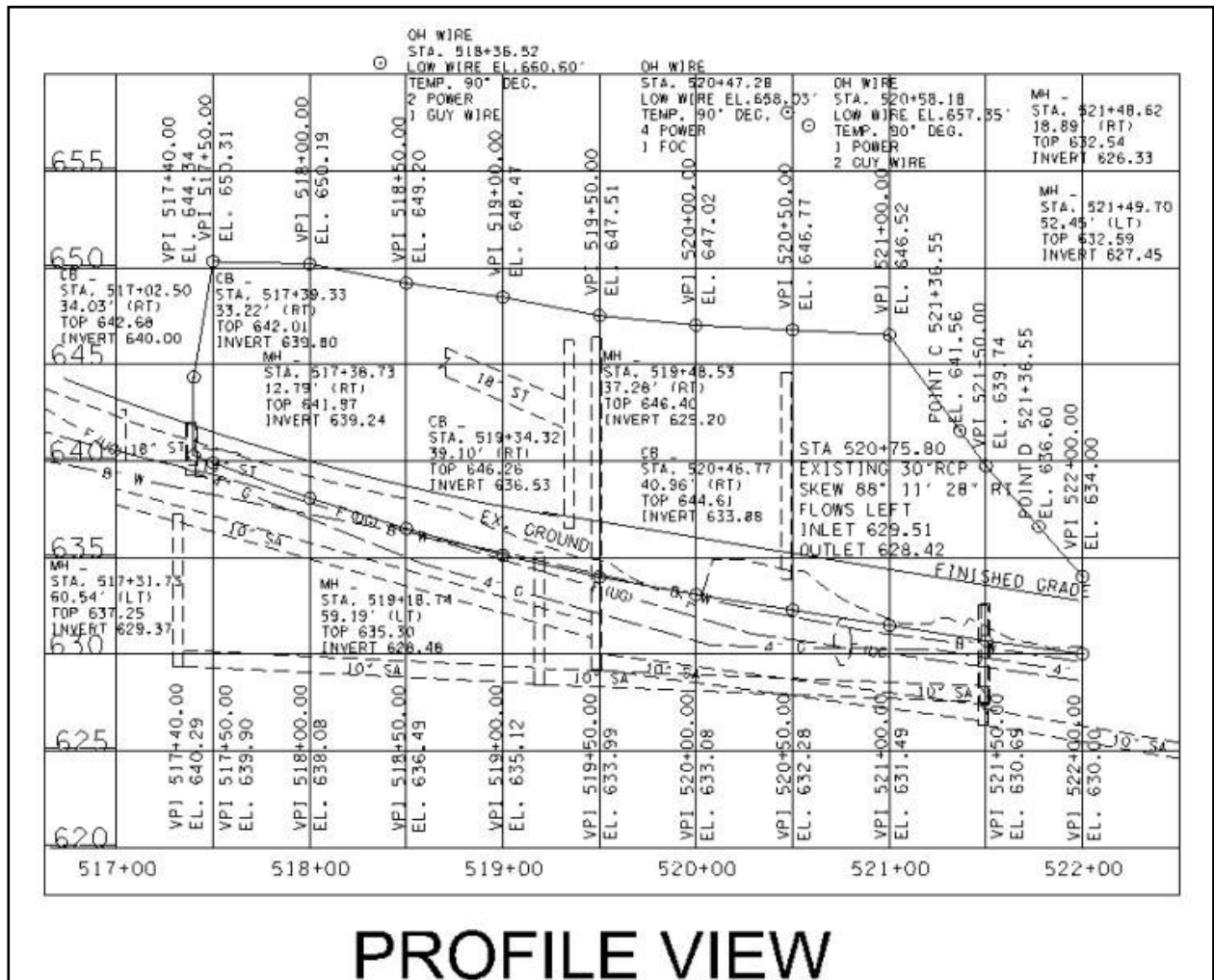

PROFILE VIEW

Figure 2-17
Example Retaining Wall Profile View

The example profile view displays existing drainage, utilities, etc. The designer shall make the decision to display additional features (existing and proposed utilities (if available), drainage structures, etc.) as long as clarity is not an issue. The profile sheet in the plans shall show all of these features.

Typical Section: The Designer shall show a typical section of the retaining wall. The chart shown in Plan View represents all stations and offsets for the beginning, ending, and all breakpoints along the wall. A typical section shall be shown at the station where the minimum distance between the exposed face of the wall and the Proposed R.O.W. occurs. For this example, the minimum distance (5.26') occurs at Sta. 521+36.55, Point "C". The Present and Proposed R.O.W. lines shall be shown and labeled with the distance between the centerline and Proposed R.O.W. labeled as "R.O.W. Varies" or as a defined distance for areas with fixed R.O.W. width. Slope and

TDOT ROADWAY DESIGN GUIDELINES – PDN
CHAPTER 2 GEOMETRIC DESIGN CRITERIA

English

Revised:

construction easements shall be shown and labeled if applicable. The offset from the roadway centerline to the exposed face of the retaining wall shall be labeled. The offset does not include wall thickness. **Note the location of the exposed face of the wall in a cut section.** The square footage of the wall shall be shown if applicable.

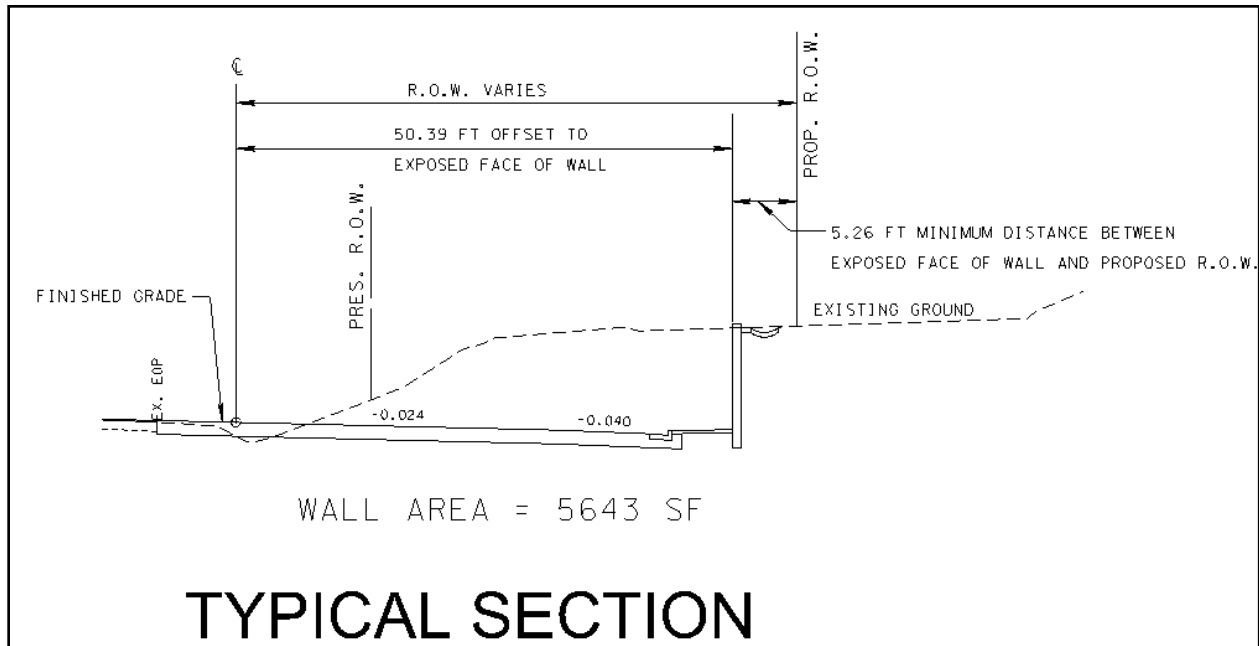

Figure 2-18
Example of Retaining Wall Typical Sections for Cut Section

For examples of walls shown in Cut and Fill Sections, see *Figure 2-18, Example of Retaining Wall Typical Sections for Cut Section* and *Figure 2-19, Example of Retaining Wall Typical Sections for Fill Section*. The typical section shall be shown to represent the section of the wall with the minimum distance between the exposed face of the wall and the Proposed R.O.W. The Present and Proposed R.O.W. lines shall be displayed and labeled with the distance between the centerline and Proposed R.O.W. labeled as “R.O.W. Varies” or as a defined distance for areas with fixed R.O.W. width. The offset from the roadway centerline to the exposed face of the retaining wall shall be labeled. **Note the location of the exposed face of the wall in a fill section.** The square footage of the wall shall also be shown, if applicable.

TDOT ROADWAY DESIGN GUIDELINES – PDN
CHAPTER 2 GEOMETRIC DESIGN CRITERIA

English

Revised:

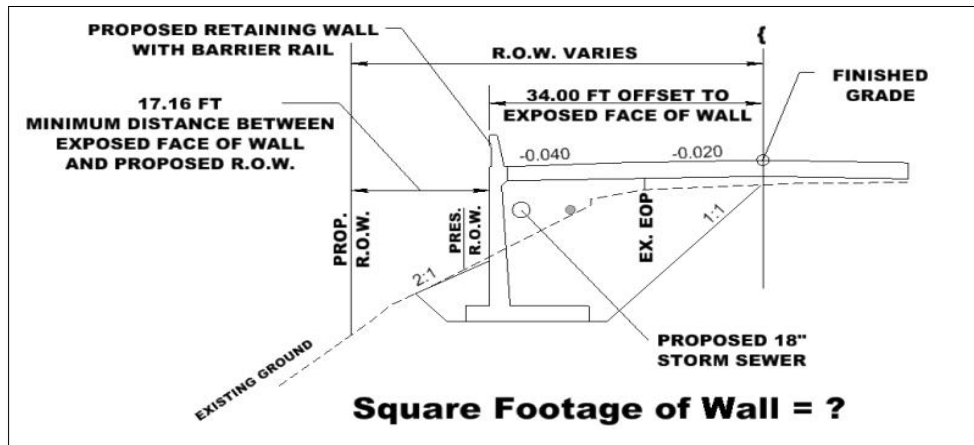

Figure 2-19
Example of Retaining Wall Typical Sections for Fill Section

See Roadway and Pavement Appurtenances - Wall Series Roadway Design Standard Drawings for additional information including retaining wall type restrictions on wall types that cannot be built within available ROW limits.

STEP 3: FILENET ARCHIVING

The Designer or Consultant Manager shall place the following files in a compressed file and place it on FileNet with the name:

nnnnnn-nn-Retainingwall.zip

- Roadway plan sheets including present, proposed, profile, and cross-section as defined in Step 1(.tin and .gpk files)
- Survey, Proposed and Alignment Files, and cross sections cut at intervals as defined in Step 1
- Retaining Wall (R#A) Geometric Layout Sheet as defined in Step 2(.dgn)
- Retaining Wall Design Letter as shown in Step 4 (.docx)

STEP 4: RETAINING WALL DESIGN LETTER

The Project Development Manager shall email the Proposed Retaining Wall Design letter (see *Figure 2-20, Example Proposed Retaining Wall Design Letter*, for example) to the Retaining Wall email address of the Structures Division (TDOT.StructuresRW@tn.gov) and CC the Geotechnical Engineering Section (TDOT.Geotech@tn.gov) and the Designer. For projects where the wall crosses over a waterway or connects to a bridge over a waterway, the Hydraulic

TDOT ROADWAY DESIGN GUIDELINES – PDN
CHAPTER 2 GEOMETRIC DESIGN CRITERIA

English

Revised:

Section of the Structures Division (TDOT.Structures@tn.gov) shall also be included in the email distribution. Any additional requirements on the wall shall be noted in the letter (such as a barrier system, light and/or signal pole, sign, or ITS features incorporated into the wall). If there is proposed lighting or signals in proximity to the wall, TDOT.TrafficOps.Sign-Reviews@tn.gov and/or TDOT.TrafficOps.SNL-Reviews@tn.gov shall be included in the email distribution. If there is an ITS feature concerning the wall, TDOT.TrafficOps.ITS-Reviews@tn.gov shall be included in the email distribution.

The subject line in the email distribution shall be noted by:

**Region X, County Name, Project Description (as shown in POS), Federal
Project Number, State Project Number, PIN nnnnnn-nn, Retaining Wall
Design**

The Designer shall archive the Proposed Retaining Wall Design letter on FileNet as part of the zip file (Refer to Step 3: FileNet Archiving).

**TDOT ROADWAY DESIGN GUIDELINES – PDN
CHAPTER 2 GEOMETRIC DESIGN CRITERIA**

English

Revised:



PROPOSED RETAINING WALL DESIGN

TO: Structures Division, TDOT.StructuresRW@tn.gov
FROM: Project Development Manager
DATE: [Click here to enter a date.](#)
SUBJECT: COUNTY:
PIN:
PROJECT NO.
PROJECT DESCRIPTION:

During the development of the subject project, our office determined retaining walls shall be considered. I am requesting the Structures Division coordinate with the Geotechnical Section to evaluate each retaining wall to determine if the retaining wall is a feasible option for locations as shown on the plans and request that they coordinate the acquisition of soil surveys deemed necessary by the structural designer. Please notify our office immediately if a wall is deemed not to be a feasible solution.

The retaining wall information shown on the preliminary plans is conceptual in nature; therefore, any changes to the length, location, or footprint of proposed walls could affect R.O.W. in an already constrained location. Please note the following R.O.W. restrictions, known environmental constraints, or project commitments when determining your design and approved alternatives: ([Designer to enter all R.O.W. restrictions, environmental constraints, and/or project commitments for each wall location here](#))

The *Retaining Wall Detail (R1A.sht, R2A.sht, etc.) Geometric Layout* sheet(s) and related files are on FileNet under the name: *nnnnn-nn-RetainingWall.zip*. For all walls, additional information or changes to all *Retaining Wall Detail (R1A.sht, R2A.sht, etc.) Geometric Layout* sheet(s) pertaining to wall length, location, or footprint of the wall shall be provided to the TDOT Project Development Designer or Consultant Designer by this date [Click here to enter a date.](#) (Designer to enter date three weeks prior to the date scheduled to print for the R.O.W. Field Review).

For each wall **designed** by the Structures Division, the Structures Division shall also provide Preliminary *Retaining Wall Details (R1.sht, R2.sht, etc.) Geotechnical Design Notes* sheet(s) for insertion into the plans for R.O.W. field review by this date [Click here to enter a date.](#) (Designer to enter date one week prior to the date scheduled to print for R.O.W. Field Review distribution). *Retaining Wall Details (R1B.sht, R2B.sht, etc.) Soil Profiles and Details* sheet(s) **shall not** be provided.

For each wall **not designed** by the Structures Division, the *Retaining Wall Details (R1.sht, R2.sht, etc.) Geotechnical Design Notes* and *Retaining Wall Details (R1B.sht, R2B.sht, etc.) Soil Profiles and Details* sheet(s) **shall not** be provided for the R.O.W. Field Review.

This project will have a Design Meeting (PPRM Activity #400) on [Click here to enter a date.](#)

For further information, please contact: _____, Phone: (_____) _____ - _____, Email: _____.

CC: Geotechnical Engineering Section: TDOT.Geotech@tn.gov
Project Delivery Designer (Enter Email)
Or Consultant Designer
Traffic Operations Division:
If plans include ITS Communication TDOT.TrafficOps.ITS-Reviews@tn.gov
If plans include signals and/or lighting TDOT.TrafficOps.SNL-Reviews@tn.gov

**Figure 2-20
Example Proposed Retaining Wall Design Letter**

**TDOT ROADWAY DESIGN GUIDELINES – PDN
CHAPTER 2 GEOMETRIC DESIGN CRITERIA**

English

Revised:

2-900.03 RETAINING WALL ASSESSMENT AT SITE REVIEW

At the Site Review, the Structures Division and the Geotechnical Engineering Section will analyze all proposed retaining wall(s), ensure there are no other alternatives but to build the wall(s), and use the checklist (*Figure 2-21, Retaining Wall Constructability Check List in Site Review Document*) within the Site Review document to determine if the wall(s) are susceptible to constructability issues:

<p>Retaining Wall Number ____ Road Name/Sta. Range: _____</p> <p>1. Circle all of the following that may apply:</p> <ul style="list-style-type: none">a. The footprint of the wall is within 10' of R.O.W.b. Existing and/or Proposed Utilities (Signal Poles, TVA towers or fixed Structures) are near the footprint of the wallc. Existing and /or Proposed Drainage Structures are near the footprint of the walld. Foundation Improvement for the wall could affect traffic phasinge. This is a Top Down Constructed wall (Soldier Pile\Lagging, Soil Nail)f. This wall is needed to mitigate pyritic materialg. This wall will be greater than 10 feet in heighth. There are 2 or more traffic phases (affect when the wall is built)i. ITS Infrastructure is within 10 feet of the footprint of the wallj. There is a RR adjacent to the wall (RR usually does not want MSE wall)k. The wall is within the clear zonel. The proposed slope in front of the wall is 2:1 or steeper or zero percentm. There are environmental limitations (wetlands near or needs stream relocation, etc.) <p>When 3 or more are circled, the wall will be considered to be susceptible to constructability issues.</p>

**Figure 2-21
Retaining Wall Constructability Check List in Site Review Document**

Once the analysis is complete, the wall is classified into one of these categories:

1. Category One -Retaining walls **WITH** constructability issues
2. Category Two- Retaining walls **WITHOUT** constructability issues

TDOT ROADWAY DESIGN GUIDELINES – PDN
CHAPTER 2 GEOMETRIC DESIGN CRITERIA

English

Revised:

2-900.04 GUIDELINES FOR CATEGORY ONE RETAINING WALLS

For Category One retaining walls with constructability issues, the following guidance shall be used for each wall:

1. The Structures Division or a Structures Consultant **shall design** the wall.
2. The Plan-In-Hand Field Review and plans shall contain the **Retaining Wall (R#) Geotechnical Design Notes and Requirements** sheet(s). These sheets shall be delivered to Project Development by the date noted in the Retaining Wall Design Letter to allow the designer to print for Plan-In-Hand Field Review Distribution. Updates to the sheet(s) as a result of comments from the Plan-In-Hand Field Review shall be completed and returned to Project Development for insertion into Plan-In-Hand plans.
3. The **Retaining Wall (R#) Geotechnical Design Notes and Requirements** sheet(s) shall list **only one** allowable wall type.
4. If there are R.O.W./Easement station ranges that shall remain clear of utilities or there are other restrictions, it shall be noted on the **Retaining Wall (R#) Geotechnical Design Notes and Requirements** sheet(s). Because this sheet is part of the submittal, it is not necessary to add the note to a Project Commitment sheet.
5. If an agreement has been made between the department and a city or county concerning a specific decorative wall finish, Project Development shall notify Structures and Geotech immediately for approval. A note shall be added to the **Retaining Wall (R#) Geotechnical Design Notes and Requirements** sheet(s) and can also be added as a project commitment. See [Chapter 2-900.06, Decorative Facing on Retaining Walls](#).
6. The Plan-in-Hand Field Review and plans shall contain the **Retaining Wall (R#A) Geometric Layout** sheet(s). The proposed square footage of the wall shall be shown on the sheet. Information for the sheet shall be delivered by the date noted in the Retaining Wall Design Letter to allow Project Development the time necessary to make any changes recommended by the Structures Division.
7. Any revisions concerning the retaining wall shall be processed by Project Development with changes to the sheet(s) completed by the appropriate division(s).
8. The PS&E Field Review plans shall contain the **Retaining Wall Estimated Quantities (R)** sheet(s), **Retaining Wall (R#) Geotechnical Design Notes and Requirements** sheet(s), **Retaining Wall R#A) Geometric Layout** sheet(s), and the **Retaining Wall (R#B) Soil Profiles and Details** sheet(s) for each wall. Project Development shall request sheets developed by the Structures Division a minimum of two months prior to the print date for PS&E Field Review plans distribution. Updates shall be made to the sheet(s) as a result of comments from the PS&E Field Review and Constructability Review held by Headquarters Construction and Regional Operations, if applicable. Project Development shall send the updated **Retaining Wall (R#A) Geometric Layout** sheet(s) for each wall to the Structures Division for insertion into the final PS&E plans a minimum of two weeks prior to the Construction submittal date and shall not include the sheets in the Roadway plans submittal. The Structures Division shall seal and submit all sheets pertaining to retaining walls at PS&E submittal.
9. Value Engineering change proposals **shall not** be accepted from contractors for category one retaining walls.

TDOT ROADWAY DESIGN GUIDELINES – PDN
CHAPTER 2 GEOMETRIC DESIGN CRITERIA

English

Revised:

2-900.05 GUIDELINES FOR CATEGORY TWO RETAINING WALLS

For Category Two retaining walls without constructability issues, the following guidance shall be used for each wall:

1. The Structures Division **shall not design** the wall.
2. The Plan-in-Hand Field Review and Plans **shall** contain the **Retaining Wall (R#A) Geometric Layout** sheet(s) only. The proposed square footage of the wall shall be shown on this sheet. Information for the sheet shall be delivered by the date noted in the Retaining Wall Design Letter to allow Project Development the time necessary to make any changes recommended by the Structures Division.
3. **Retaining Wall (R#) Geotechnical Design Notes and Requirements** sheet(s) shall not be completed for Plan-In-Hand Field Review and plans; thus project commitments must be added to the project commitment sheet for the wall if there are R.O.W./easement station ranges that shall remain clear of utilities or other restrictions.
4. **Retaining Wall (R#) Geotechnical Design Notes and Requirements** sheet(s) shall not be completed for Plan-In-Hand Field Review and plans. plans; thus project commitments must be added if an agreement has been made between the department and a city or county concerning a specific decorative wall finish. Project Development shall notify Structures and Geotech immediately for approval. (See [Chapter 2-900.06, Decorative Facing on Retaining Walls.](#))
5. The PS&E Field Review plans shall contain the **Retaining Wall Estimated Quantities (R)** sheet(s), **Retaining Wall (R#) Geotechnical Design Notes and Requirements** sheet(s), **Retaining Wall (R#A) Geometric Layout** sheet(s), and the **Retaining Wall (R#B) Soil Profiles and Details** sheet(s) for each wall. Project Development shall request sheets developed by the Structures Division and the Structure Estimate a minimum of two months prior to the proposed date to print PS&E Field Review plans for distribution. Updates shall be made to the sheet(s) as a result of comments from the PS&E Field Review.
6. Any project commitments added to the Project commitment sheets for R.O.W. submittal shall be removed and only be shown in the **Retaining Wall (R#) Geotechnical Design Notes and Requirements** sheet(s) to ensure that there is only one note pertaining to the wall and diminish the likelihood of conflicting notes. Structures and Project Development shall work together to ensure that the notes are covered in the correct sheets.
7. Project Development shall send the updated **Retaining Wall (R#A) Geometric Layout** sheet(s) for each wall to the Structures Division for insertion into the final PS&E plans a minimum of two weeks prior to the PS&E submittal date. This sheet shall not be turned in with the Roadway Plans. The retaining wall shall be designed by the contractor that was awarded the project. Walls designed and constructed by the contractor **shall be limited to the approved alternatives** for the wall as specified on the **Retaining Wall (R#) Geotechnical Design Notes and Requirements** sheet(s).
8. See [Chapter 2-900.07, Retaining Wall Quantities](#)

**TDOT ROADWAY DESIGN GUIDELINES – PDN
CHAPTER 2 GEOMETRIC DESIGN CRITERIA**

English

Revised:

2-900.06 DECORATIVE FACING ON RETAINING WALLS

If the outside entity requests a decorative facing on walls, TDOT shall recommend the acceptable wall types for that finish. The wall finish shall be compatible with the Department's acceptable wall types. However, if the decorative facing is compatible with the acceptable wall type but unique in appearance, the additional cost of the decorative facing shall be paid for by the county/city. An estimate for the additional cost of the decorative facing shall be calculated by the Structures Division. The Project Development Manager and the Structures Manager overseeing the wall design shall contact the Local Programs Development Office at Local.Programs@tn.gov to discuss a potential contract between TDOT and the entity for the additional costs of the decorative finish.

2-900.07 RETAINING WALL QUANTITIES

Accurate retaining wall quantities are necessary when preparing an estimate for the project during the lifetime of the project. Retaining wall quantities must be estimated as early as possible and included in the request for R.O.W. funding. The quantities must also be included in any R.O.W. revisions that include retaining wall quantities.

Project Development shall calculate the following **roadway items** as applicable associated with each retaining wall:

ITEM NO.	DESCRIPTION	QUANTITY
620-05	CONCRETE PARAPET WITH STRUCTURAL TUBING	L.F.
620-10	CONCRETE PARAPET WITH PEDESTRIAN RAILING	L.F.
711-05.70	32" SINGLE SLOPE CONCRETE BARRIER WALL	L.F.
711-05.71	51" SINGLE SLOPE CONCRETE BARRIER WALL	L.F.

Structures and Geotech personnel shall calculate the quantity for each retaining wall. Each retaining wall shall be paid for separately utilizing Item Numbers 604-07.01 through 604-07.XX, as needed, with quantities calculated in square feet (S.F.).

ITEM NO.	DESCRIPTION	QUANTITY
*604-07.01 through 604-07.XX	RETAINING WALL (DESCRIPTION)	S.F.

NOTE: The description shall be filled in with the wall number, beginning and end station, and the location of the wall in reference to the centerline of the associated road, ramp, or side road left (LT) or right (RT).

Example: 604-07.01 RETAINING WALL (R1, STA. 500+00.00 to STA. 502+05.00, LT)

Example: 604-07.02 RETAINING WALL (R2, STA. 603+15.00 to STA. 604+55.00, RT)

TDOT ROADWAY DESIGN GUIDELINES – PDN
CHAPTER 2 GEOMETRIC DESIGN CRITERIA

English

Revised:

The following quantities are **INCLUDED** in the square footage of the wall and shall not be listed as separate pay items:

ITEM NO.	DESCRIPTION	QUANTITY
203-40.10	TIE-BACK ANCHORS (SOIL)	L.F.
203-40.11	TIE-BACK ANCHORS (ROCK)	L.F.
203-40.12	TIE-BACK ANCHORS (3-STRAND UNCLASSIFIED)	L.F.
203-40.13	TIE-BACK ANCHORS (4-STRAND UNCLASSIFIED)	L.F.
203-40.14	TIE-BACK ANCHORS (5-STRAND UNCLASSIFIED)	L.F.
203-40.18	TIE-BACK ANCHORS (ABANDONED)	L.F.
604-01.52	CUSTOM ELASTOMERIC FORM LINER	LS
604-04.01	APPLIED TEXTURE FINISH (NEW STRUCTURES)	S.Y.
710-09.01	6" PERFORATED PIPE WITH VERTICAL DRAIN SYSTEM	L.F.

Structures and Geotech personnel shall calculate the foundation quantities associated with each Category 1 retaining wall **only**. For gravity type retaining walls, the Roadway Designer will use standard drawings and associated item numbers. **Foundation Items** for each retaining wall shall be paid for separately and are not included in the square footage of the wall. Foundation items include but are not limited to the following:

ITEM NO.	DESCRIPTION	QUANTITY
203-02.01	BORROW EXCAVATION (GRADED SOLID ROCK) (off site)	TON
203-02.02	BORROW EXCAVATION (GRADED SOLID ROCK) (on site)	C.Y.
203-03.01	BORROW EXCAVATION (SELECT MATERIAL)	C.Y.
203-03.05	BORROW EXCAVATION (SELECT MATERIAL)	TON
606-03.03	STEEL PILES (12 INCH)	L.F.
606-03.05	STEEL PILES (12 INCH) COLUMN	L.F.
606-04.03	STEEL PILES (14 INCH)	L.F.
606-04.05	STEEL PILES (14 INCH) COLUMN	L.F.
625-02.01 through 625- 02.06	DRILLED SHAFT-SOIL (DIA.)	V.F.
625-02.13 through 625- 02.18	DRILLED SHAFT-ROCK (DIA.)	V.F.
625-02.25 through 625- 02.30	DRILLED SHAFT CASING-PERMANENT (DIA.)	V.F.
625-02.40	DRILLED SHAFT (SH-SCC) CONCRETE	C.Y.
625-02.44	DRILLED SHAFT REINFORCING STEEL	LB.
626-01.01	AGGREGATE FOUNDATION SYSTEMS	L.S.
740-10.04	GEOTEXTILE (TYPE IV) (STABILIZATION)	S.Y.
930-08.26	LOADING TEST (SOIL NAILS)	EACH
Numerous Items	DRILLING	

TDOT ROADWAY DESIGN GUIDELINES – PDN
CHAPTER 2 GEOMETRIC DESIGN CRITERIA

English

Revised:

2-900.08 R.O.W. FUNDING REQUEST AND R.O.W. REVISIONS

Accurate retaining wall quantities are necessary when preparing an estimate for the project. It is essential that the quantities are estimated as early as possible and included in the request for R.O.W. or Utilities Only funding and included in an updated estimate of R.O.W. when revisions to proposed walls occur that affect quantities.

The Project Manager requests R.O.W. or Utilities Only funding following the Functional Design field review. All changes in retaining wall quantities as a result from the Functional Design Field Review shall be addressed prior to requesting funding. An Estimated Roadway Quantity Excel file is included in the R.O.W. funding request submittal package. The Structures Division does not turn in an estimate for the Functional Design phase; thus, it is essential that the Project Manager communicate with the Structures Manager to obtain applicable pay items for each wall to be included in the Estimated Roadway Quantity Excel file. At a minimum, the roadway items pertaining to the wall and square footage of the wall shall be in the Excel file (See [Chapter 2-900.07, Retaining Wall Quantities](#)). Any other available quantities provided by Structures shall be included in the Excel File.

If there are significant changes, additions, deletions, etc. to the retaining wall(s) after R.O.W. or Utilities Only submittal, a plans revision shall be distributed and shall include an updated Estimated Roadway Quantity Excel file. The Project Manager or Designer shall include the updated estimate in the R.O.W. revision email distribution to TDOT.Preliminary.Estimates@tn.gov and TDOT.PDSO@tn.gov. The email shall state that the estimate is updated and refer to the R.O.W. revision letter for additional information. If a proposed retaining wall was considered a Category Two wall in the R.O.W. submittal but becomes a Category One wall during the development of the project, a R.O.W. revision must be distributed with the additional sheets added to the plans.

2-900.09 PS&E FIELD REVIEW, SUBMITTAL, AND REVISIONS

Project Development and Structures shall follow the steps as outlined in [Chapter 2-900.04, Guidelines for Category One Retaining Walls](#) and [Chapter 2-900.05, Guidelines for Category Two Retaining Walls](#) for both the PS&E Field Review and Final Construction plans submittal. Project Development personnel shall ensure that all pay items except those specified as roadway items shall be removed from the Estimated Roadway Quantity Excel File.

If there are significant changes, additions, deletions, etc. to the retaining wall(s) after PS&E submittal, a plans revision shall be distributed for sheet *(R) Retaining Wall Estimated Quantities* and shall include an updated Estimated Roadway Quantity Excel file for retaining wall roadway quantities, if applicable.

2-900.10 RETAINING WALL FOOTNOTES ON PS&E PLANS

The Designer shall add the following footnote on the Estimated Roadway Quantity sheet

TDOT ROADWAY DESIGN GUIDELINES – PDN
CHAPTER 2 GEOMETRIC DESIGN CRITERIA

English

Revised:

for PS&E Field Reviews and final Construction plans on all projects that have retaining walls:

1. ALL COST OF BUILDING AND INSTALLING THE RETAINING WALL, INCLUDING FOUNDATION PREPARATION, BACKFILLING, AND EXCAVATION, SHALL BE INCLUDED IN THE SQUARE FOOTAGE COST OF THE RETAINING WALL. QUANTITIES FOR FOUNDATION PREPARATION, BACKFILL, AND EXCAVATION ARE REFLECTED IN THE END AREA CALCULATIONS ON CROSS SECTIONS AND IN GRADING QUANTITY ROADWAY ITEM 203-01, ROAD AND DRAINAGE EXCAVATION (C.Y.). THE DESIGNER HAS NOTED THE PORTION OF THIS QUANTITY FOR THESE ITEMS ON THE PROFILE SHEET XX AND ON THE GRADING QUANTITY TABULATION SHEET. THE PORTION OF THIS QUANTITY HAS BEEN REMOVED FROM ROADWAY ITEM 203-01, ROAD AND DRAINAGE EXCAVATION (C.Y.). FOR FURTHER INFORMATION ON RETAINING WALLS AND QUANTITIES, SEE SHEET(S) (R, R1, R1A, R1B, R2, R2A, R2B, etc.).

If a Concrete Parapet is on one retaining wall, the quantity shall be shown as a roadway item and the following footnote shall be added:

2. CONCRETE PARAPET IS LOCATED ON RETAINING WALL R# AND IS NOT INCLUDED IN THE COST OF THE RETAINING WALL.

If Concrete Parapet is on multiple retaining walls, the quantity shall be shown as a roadway item and the following footnote shall be added:

3. CONCRETE PARAPET IS NOT INCLUDED IN THE COST OF THE RETAINING WALL. BREAKDOWN OF CONCRETE PARAPET FOR EACH WALL IS XX L.F. FOR R#, XX L.F. FOR R#, XX L.F. FOR R#, (ETC.)

If Concrete Barrier is on one retaining wall, the quantity shall be shown as a roadway item and the following footnote shall be added:

4. CONCRETE BARRIER IS LOCATED ON RETAINING WALL R# AND IS NOT INCLUDED IN THE COST OF THE RETAINING WALL.

If Concrete Barrier is on multiple retaining walls, the quantity shall be shown as a roadway item and the following footnote shall be added:

5. CONCRETE BARRIER IS NOT INCLUDED IN THE COST OF THE RETAINING WALL. BREAKDOWN OF CONCRETE BARRIER FOR EACH WALL IS XX L.F. FOR R#, XX L.F. FOR R#, XX L.F. FOR R#, (etc.)

2-900.11 RETAINING WALL BARRIER SYSTEM REQUIREMENTS

The Designer shall show proper barrier type associated with the acceptable wall type. See the Roadway and Pavement Appurtenances - Wall Series Roadway of Design Standard Drawings for type and placement of barrier.

TDOT ROADWAY DESIGN GUIDELINES – PDN
CHAPTER 2 GEOMETRIC DESIGN CRITERIA

English

Revised:

Retaining walls in fill sections may require a barrier system due to the drop off. If there is sufficient room, the barrier system should be placed away from the wall. If the only option is to include the barrier as part of the wall, the Designer shall notify the Structures Division.

Retaining walls in cut sections may require a barrier system. Generally, all retaining wall types inside the clear zone require a concrete barrier. If the wall is outside of the clear zone, a retaining wall may not be required unless deemed appropriate by engineering judgment.

SECTION 10 – EARTHWORK DESIGN

2-1000.00 EARTHWORK CONSIDERATIONS

The earthwork design is dependent on all the other roadway design elements, such as horizontal alignment, vertical alignment, roadway cross section, etc. The designer must use good engineering judgement to achieve an appropriate balance between all these elements to provide a final roadway design that meets all the constraints for a particular project. One of the major tasks in roadway construction is removing and placing earth materials to achieve the desired earth grade cross-section. The Designer should define where the roadway material is to be obtained, where it will be placed, and the amount of material to be excavated, etc. when developing plans. This section will discuss information that should be taken into consideration when a Designer is calculating earthwork and trying to balance their job.

The geotechnical report and geotechnical related drawings should be consulted by the Roadway Designer to determine what type of materials will be encountered during excavation and embankment construction for a project. The geotechnical report should provide enough information to determine the type materials described below and project specific recommendations for shrink and swell factors. It is recommended that the Designer contact the Geotechnical Engineering Section (TDOT.Geotech@tn.gov) of the Materials and Test Division as needed to clarify any questions arising regarding the nature of materials to be encountered and accounted for in the grading tabulations and bid quantities.

The following terms and definitions will be used by all TDOT Divisions so that a consistent definition is used in all phases of project development and in contract documents. Guidance to Designers as to the material breakdown to be shown on the plans and cross-sections should be found in the geotechnical report.

A. **SOIL MATERIAL**

Soil material is material that is predominantly made up of naturally occurring mineral particles which are readily separated into relatively small pieces, and in which the mass may contain air, water, or organic materials. This material may contain rock pieces in the form of disconnected slabs, lenses, or boulders of less than approximately 0.5 cubic yards. The main soil groups consist of clay, silt, sand, gravel, cobbles, boulders (less than 0.5 cubic yard volume) or a combination of any of the constituents. For construction purposes, this material would typically be considered to be excavatable by conventional excavation machinery such as pans, track hoes, or front-end excavators/loaders. This material would have a shrink factor as given in the shrink factors shown in Section 2-405.05, Shrinkage and Swell Factors, of the Design Guidelines or as recommended by the Geotechnical Engineering Section of the Materials and Tests Division.

TDOT ROADWAY DESIGN GUIDELINES – PDN
CHAPTER 2 GEOMETRIC DESIGN CRITERIA

English

Revised:

- B. SOLID ROCK MATERIAL
Solid rock material is that naturally occurring material, composed of mineral particles so firmly bonded together; great effort is required to separate the particles (i.e. blasting or heavy crushing forces). For construction purposes, this material would typically have to be blasted to separate into pieces small enough to load and transport on earth moving trucks and which when subjected to proper pre-split and production blasting would result in a uniform stable rock cut face. Note that this material would not by definition necessarily be a proven source of any rock type aggregate such as solid rock, graded solid rock, rip rap, or other rock aggregate construction products. This material would have a significant swell factor as given in swell factors shown in [Chapter 2-1002.00, Shrinkage and Swell Factors](#), of the Design Guidelines or as recommended by the Geotechnical Engineering Section of the Materials and Tests Division.
- C. SOFT ROCK OR DEGRADABLE ROCK
This material is that naturally occurring material composed of mineral particles that are so firmly bonded such that they are not separated into small pieces yet has such relatively low bonding strength that would allow for separating into small pieces through moderate to heavy crushing forces. For construction purposes this material would have to be subjected to ripping type equipment, hoe rams, or rugged use of a large bulldozer in order to separate the material such that it can be readily loaded into earth moving trucks. These materials would typically be shales, claystones, siltstones, weathered sandstones, weathered schist and weathered gneiss. This material would have a relatively small shrink or swell factor depending on the type material and the degree of weathering, disintegration, or degradation.
- D. TRANSITIONAL MATERIALS
This material is that material comprised of a combination of soil and rock (Materials A, B, and C as defined above) occurring in either non-uniform interbedded layers of the above materials (i.e. shale material with relatively thin layers of solid rock such as hard limestone) or erratic localized changes of material types both laterally and with depth (such as a geologic formation resulting in pinnaced rock columns, floating boulders or lenses intercalated with clay soil, a common occurrence in certain regions of Tennessee). For construction purposes, this material may have to be excavated using a combination of excavation methods such as blasting of rock pinnacles, layers or boulders along with a ripping of weathered rock and excavating of soil with track hoes or loaders all within a localized area. This material would not be suitable for the use of excavating pan type equipment.
- E. COMMON EXCAVATION
Common excavation is that sum of materials excavated from a project inclusive of all those materials described in **A**, **C**, and **D** above. The grouping of these materials

TDOT ROADWAY DESIGN GUIDELINES – PDN
CHAPTER 2 GEOMETRIC DESIGN CRITERIA

English

Revised:

is to generally define those materials that would not generally be acceptable to permanently place on a pre-split, blasted face and also to define those materials that would not be considered a source of a defined fill material such as solid rock fill, graded solid rock, rip rap or other rock type aggregates. Typically the materials in this grouping would have either a shrink factor or a relatively low swell factor as compared to solid rock material described in B above.

F. UNCLASSIFIED EXCAVATION

Unclassified excavation is that sum of materials excavated from a project inclusive of all those items described in **A**, **B**, **C**, and **D** above. On most projects, road and drainage excavation will be listed as unclassified and is to be bid as one item regardless of the type material encountered. See Section 203.02(a) of the Standard Specifications for Road and Bridge Construction.

2-1001.00 EARTHWORK BALANCES ON WIDENING OF EXISTING ROADWAYS

When balancing the earthwork on a project that involves a grade change on the existing roadway, attention needs to be paid to the construction sequencing. It is not possible to maintain traffic on the existing roadway and, at the same time, use material from that roadway to lower the grade, or conversely, to add material to raise the grade of the existing roadway.

When the Designer considers the need to stockpile material, detour traffic, or maintain traffic by other means, this shall be detailed in the traffic control plans, earthwork balances, or elsewhere as deemed appropriate.

When widening symmetrically along the existing roadway, please request HQ Geotech to core the existing roadway pavement to ensure that the pavement structure is adequate for the widening if additional measures and/or full depth replacement of the existing pavement is needed to meet the needs of the 20 year design.

2-1002.00 SHRINKAGE AND SWELL FACTORS

Although the recommended shrink and swell factors to be used for each project are to be requested from the Geotechnical Engineering Section, below is some general guidance. Shrinkage and swell of earth and rock material vary with types of material, weather conditions, equipment used, depth of cuts and fills, and length of haul. Table 2-5, *Shrink and Swell Factors* are examples and are offered as a guide.

**TDOT ROADWAY DESIGN GUIDELINES – PDN
CHAPTER 2 GEOMETRIC DESIGN CRITERIA**

English

Revised:

Light Cut and Fills	
1 – 2 foot cut and fills	Earth 30% to 50% Chert 20% to 30%
2 – 4 foot cut and fills	Earth 25% to 30% Chert 10% to 15%
4 - 6 foot cut and fills	Earth 15% to 20% Chert 8% to 12%
Heavy Cut and Fills	Earth 10% Chert 0% to 8%
Heavy Cuts and Light Fills	
Cuts 12 feet+, Fills 1 - 2 feet (average)	Earth 15% to 20% Chert 5% to 10%
Cuts 12 feet+, Fills 2 – 4 feet (average)	Earth 10% to 15% Chert 5% to 10%
Shale and Slate	5% to 10% shrinkage; varies with type of material
Sandstone	0% shrinkage to 15% swell; varies with type of material and weather conditions
Limestone	If material is a small percentage and mixed with embankment, 0% shrinkage Heavy cuts and fills: 15% to 20% swell Light fills: 20% swell
Light work through wooded areas call for heavier shrinkage.	
Do not call for rock to be placed in fills less than 3 feet in height unless requested by the Geotechnical Engineering Section.	

**Table 2-5
Shrink and Swell Factors**

2-1003.00 GRADING LINE THROUGH SOLID ROCK

Do not show a solid rock grading line on the typical sections. Specifications for excavation of rock at the subgrade and where rock slopes are to be seeded are covered in the [TDOT Standard Specifications for Road and Bridge Construction](#).

TDOT ROADWAY DESIGN GUIDELINES – PDN
CHAPTER 2 GEOMETRIC DESIGN CRITERIA

English

Revised:

2-1004.00 PRESPLITTING OF ROCK EXCAVATION

On all projects having rock excavation, a quantity shall be included for pre-splitting the rock at the outside limits of the cut areas containing the rock. Pre-splitting shall not be required on slopes flatter than 1:1 as per Section 203 of the Standard Specifications.

The quantity of pre-splitting shall be computed from the roadway cross-sections and paid for under Item Number 203-01.11 Presplitting of Rock Excavation per S.Y. or Item Number 203-01.12 Oriented Presplitting of Rock Excavation per S.Y.

2-1005.00 CAPPING ROCK FILLS

In areas where a solid rock fill is expected and grassed slopes are designed, provide road and drainage excavation (unclassified) or borrow excavation (unclassified) in sufficient quantity to cap these fills with a minimum of ± 9 inches of common material before placing topsoil and seeding.

2-1006.00 EARTHWORK BALANCES IN PLANS

Earthwork balances shall be computed using average end areas. Examples of how to calculate earthwork balances are as follows:

1. Calculation procedure for balanced Earthwork.

250,000 C.Y.	Exc. (Common)
-13,000 C.Y.	Topsoil from Exc. Areas
<u>- 5,000 C.Y.</u>	Topsoil from Emb. Areas
232,000 C.Y.	Exc. (Common) available for balance

Exc. (Com) x (1 – 0.15) + [Exc. (Rock) x 1.15] vs. Emb.

232,000 x 0.85 + (45,000 x 1.15) vs. 248,950 C.Y.

197,200 + 51,750 vs. 248,950 C.Y.

248,950 C.Y. = 248,950 C.Y.

2. Calculation procedure for unbalanced Earthwork.

350,000 C.Y. Exc. (Common)

**TDOT ROADWAY DESIGN GUIDELINES – PDN
CHAPTER 2 GEOMETRIC DESIGN CRITERIA**

English

Revised:

- 13,000 C.Y. Topsoil from exc. Areas
- 5,000 C.Y. Topsoil for emb. Area
- 332,000 C.Y. Exc. (Common) available for balance

Exc. (Com) x 0.85 + [Exc. (Rock) x 1.15] vs. Emb.

332,000 x 0.85 + (45,000 x 1.15) vs. 248,950 C.Y.

333,950 C.Y. vs. 248,950 C.Y.

The 85,000 C.Y. of excess material has had the shrinkage factor applied to it (this assumes all excess material will be common). When this quantity is multiplied by the shrinkage factor (to "un-shrink" it), the excess then becomes 97,750 C.Y.

2-1007.00 TOPSOIL REQUIREMENTS FOR EARTHWORK BALANCES

In areas to be seeded or sodded, compute the quantity of topsoil required based on a 3-inch ± thickness with 100% shrinkage.

A note shall be added to the plans below the earthwork tabulation block detailing any special areas where topsoil will not be required (such as rock fills not to be seeded). Include topsoil and seeding quantities for sodded or paved ditch areas on projects requiring topsoil and seeded slopes.

Topsoil shall be secured from within the proposed roadway balances where possible. If necessary, embankment areas shall be stripped in addition to excavation areas.

When final earthwork balances are calculated, the topsoil shall be taken into account in the following manner:

1. Calculate the topsoil needed and the topsoil available to see if all the topsoil can possibly be obtained from the proposed roadway areas.
2. Adjust the cross-section end areas as necessary to reflect the topsoil that is to be stripped. These adjusted areas are to be used to balance the job.
3. Balance the project using the proper shrinkage and swell factors.
4. Include the topsoil on the estimated grading quantities tabulated block.

If no topsoil can be secured from the project area to accommodate seeding/sodding, include Item Number 203-07 Furnishing & Spreading Topsoil per C.Y. in the estimated quantities.

TDOT ROADWAY DESIGN GUIDELINES – PDN
CHAPTER 2 GEOMETRIC DESIGN CRITERIA

English

Revised:

If adequate topsoil can be secured from the project area to accommodate seeding/sodding, include Item Number 203-04 Placing and Spreading Topsoil per C.Y. in the estimated quantities.

If adequate topsoil cannot be secured from the project area to accommodate seeding/sodding, include Item Number 203-04 Placing and Spreading Topsoil per C.Y. and Item Number 203-07 Furnishing & Spreading Topsoil per C.Y. in the estimated quantities.

Using the example in [Chapter 2-1006.00, Earthwork Balances in Plans](#), a total of 18,000 C.Y. of topsoil has been stripped from the project area. According to the [TDOT Standard Specifications for Road and Bridge Construction](#), payment for stripping and stockpiling of topsoil shall be paid for under Item Number 203-01, Road & Drainage Excavation (Unclassified). Given the 100% shrinkage factor, when placing and spreading topsoil, the thickness used in calculations should be 6" since the final thickness needs to be 3".

For example, 18,000 C.Y. of topsoil spread 6" thick will cover 22.31 acres. This will be paid for under Item Number 203-04, Placing and Spreading Topsoil, per C.Y. If the project area that needs topsoil is greater than 22.31 acres, then the additional topsoil will be paid for under Item Number 203-07, Furnishing & Spreading Topsoil.

2-1008.00 ESTIMATED GRADING QUANTITIES TABULATED BLOCK

The Estimated Grading Quantities tabulated block should be shown on Sheet 2E, Tabulated Quantities Sheet. An example of the tabulated block is shown in *Table 2-6, Estimated Grading Quantities – Balanced Example* and *Table 2-7, Estimated Grading Quantities – Unbalanced Example*.

On all projects using Item No. 203-01, Road and Drainage Excavation (Unclassified), it is to be referred to as unclassified excavation. When the Designer has received the Soils and Geology Report stating approximately what portion is common and what portion is solid rock, the Designer is to include the quantities in the block, even if the quantity is zero. If the Designer does not know the composition of the material being excavated, the Designer should use write 'UNKNOWN' in the Rock cell.

**TDOT ROADWAY DESIGN GUIDELINES – PDN
CHAPTER 2 GEOMETRIC DESIGN CRITERIA**

English

Revised:

ESTIMATED GRADING QUANTITIES																		
DESCRIPTION	UNADJUSTED VOLUMES (CY)		ADJUSTED VOLUMES (CY)	BALANCE SUMMARY														
	EXC.	EMB.	EXC.	SHRINK = 15 % SWELL = 15 %														
MAINLINE	225000	237500	191250	<table style="width: 100%; border: none;"> <tr> <td style="width: 30%;">EXC.</td> <td style="width: 40%;"></td> <td style="width: 30%;">EMB.</td> </tr> <tr> <td>248950</td> <td style="text-align: center;">vs.</td> <td>-248950</td> </tr> <tr> <td>AVAILABLE</td> <td style="text-align: center;">=</td> <td>0</td> </tr> <tr> <td>WASTE MATERIAL</td> <td style="text-align: center;">=</td> <td>0</td> </tr> </table>			EXC.		EMB.	248950	vs.	-248950	AVAILABLE	=	0	WASTE MATERIAL	=	0
EXC.		EMB.																
248950	vs.	-248950																
AVAILABLE	=	0																
WASTE MATERIAL	=	0																
SIDE ROADS	7000	11450	5950															
PVT. DRIVES, BUSINESS AND FIELD ENTRANCES	0	0																
INDEPENDENT DITCHES	0	0																
TEMPORARY CONSTRUCTION EXITS	0	0																
OTHER (BRIDGE EXCAVATION, PAVEMENT, ETC...)	0	0																
TOPSOIL (EMB.)	5000																	
TOPSOIL (EXC.)	13000																	
TOPSOIL TOTALS (SEE TOPSOIL TAB)																		
ROCK (C.Y.)		TOTALS (C.Y.)																
EXC.	EMB.	EXC. (UNCL.)	EMB. (UNCL.)	EXC (COMMON)	EXC. (AVAIL.)	EXC. (ADJ.)												
45000	0	295000	248950	250000	232000	248950												

**Table 2-6
Estimated Grading Quantities – Balanced Example**

ESTIMATED GRADING QUANTITIES																		
DESCRIPTION	UNADJUSTED VOLUMES (CY)		ADJUSTED VOLUMES (CY)	BALANCE SUMMARY														
	EXC.	EMB.	EXC.	SHRINK = 15 % SWELL = 15 %														
MAINLINE	325000	375150	276250	<table style="width: 100%; border: none;"> <tr> <td style="width: 30%;">EMB.</td> <td style="width: 40%;"></td> <td style="width: 30%;">EXC.</td> </tr> <tr> <td>386600</td> <td style="text-align: center;">vs.</td> <td>-333950</td> </tr> <tr> <td>AVAILABLE</td> <td style="text-align: center;">=</td> <td>52650</td> </tr> <tr> <td>BORROW MATERIAL</td> <td style="text-align: center;">=</td> <td>60548</td> </tr> </table>			EMB.		EXC.	386600	vs.	-333950	AVAILABLE	=	52650	BORROW MATERIAL	=	60548
EMB.		EXC.																
386600	vs.	-333950																
AVAILABLE	=	52650																
BORROW MATERIAL	=	60548																
SIDE ROADS	7000	11450	5950															
PVT. DRIVES, BUSINESS AND FIELD ENTRANCES																		
INDEPENDENT DITCHES																		
TEMPORARY CONSTRUCTION EXITS																		
OTHER (BRIDGE EXCAVATION, PAVEMENT, ETC...)																		
TOPSOIL (EMB.)	5000																	
TOPSOIL (EXC.)	13000																	
TOPSOIL TOTALS (SEE TOPSOIL TABLE)																		
ROCK (C.Y.)		TOTALS (C.Y.)																
EXC.	EMB.	EXC. (UNCL.)	EMB. (UNCL.)	EXC (COMMON)	EXC. (AVAIL.)	EXC. (ADJ.)												
45000		395000	386600	350000	332000	333950												

**Table 2-7
Estimated Grading Quantities – Unbalanced Example**

TDOT ROADWAY DESIGN GUIDELINES – PDN
CHAPTER 2 GEOMETRIC DESIGN CRITERIA

English

Revised:

2-1009.00 GRADING REPORT

All grading report sheets shall show the federal and/or state project numbers, route numbers and/or street names and county on each sheet. The Designer should use the [Grading Report template](#). Each sheet shall be numbered to reflect both the individual sheet number as well as the total number of quantity sheets in the submission. See *Figure 2-22, Sample Grading Report*.

GRADING REPORT								
COMPUTED BY: Jordan Del Sardo				SHEET 1 OF 18				
CHECKED BY: David D. Layhew				STATE NO.: 65455-3623-04				
FEDERAL PROJECT NO: N/A				PIN: 124501.00				
ROUTE NO. OR STREET: Macedonia Road				COUNTY: Morgan				
ESTIMATED GRADING QUANTITIES								
DESCRIPTION	UNADJUSTED VOLUMES (CY)		ADJUSTED VOLUMES (CY)	BALANCE SUMMARY				
	EXC.	EMB.	EXC.	SHRINK = 20 % SWELL = 20 %				
MAINLINE	4235	6578	3388					
SIDE ROADS	2341	654	1873					
PVT. DRIVES, BUSINESS AND FIELD ENTRANCES				EMB.	EXC.			
INDEPENDENT DITCHES								
TEMPORARY CONSTRUCTION EXITS				7232	VS.		-6346	
OTHER (BRIDGE EXCAVATION, PAVEMENT, ETC...)	542		434					
TOPSOIL (EMB.)				AVAILABLE = 886				
TOPSOIL (EXC.)				BORROW MATERIAL = 1064				
TOPSOIL TOTALS (SEE TOPSOIL TABLE)								
ROCK (C.Y.)		TOTALS (C.Y.)						
EXC.	EMB.	EXC. (UNCL.)	EMB. (UNCL.)	EXC. (COMMON)	EXC. (AVAIL.)	EXC. (ADJ.)		
543		7661	7232	7118	7118	6346		
Macedonia Road Earthwork								
Station	Material Name	End Areas	Unadjusted	Adjusted	Mult	Mass	Accum	Accum
			Volumes	Volumes	Factor	Ordinate	Unadj Vol	Adj Vol
			(sq. ft.)	(cu. yd.)			(cu. yd.)	(cu. yd.)

2+94.13 EARTH								
	Excavation	24	0	0	1.00		0	0
	Fill	0	0	0	1.00	0	0	0
2+95.00 EARTH								
	Excavation	23	1	1	1.00		1	1
	Fill	0	0	0	1.00	1	0	0
2+97.65 EARTH								
	Excavation	123	7	7	1.00		8	8
	Fill	0	0	0	1.00	8	0	0

Figure 2-22
Sample Grading Report

SECTION 11 – TRUCK CLIMBING LANES

2-1100.00 TRUCK CLIMBING LANE DESIGN

It is desirable to provide a truck-climbing lane as an added lane for the upgrade direction of a highway where the grade, traffic volumes and heavy-vehicle volumes combine to degrade traffic operations from those on the approach to grade. This section discusses guidelines for determining the location of truck-climbing lanes, critical lengths of grade, design criteria for truck-climbing lanes and guidance on how to develop truck speed profiles. For additional guidance on these topics, see *AASHTO A Policy on Geometric Design of Highways and Streets*.

2-1100.01 LOCATION GUIDELINES

A truck-climbing lane may be necessary to allow a specific upgrade to operate at an acceptable level of service. The following criteria will apply:

Two-Lane Highways – On a two-lane, two-way highway, a truck-climbing lane should be considered if the following conditions are satisfied:

- The upgrade traffic flow is in excess of 200 veh/h; and
- The heavy-vehicle volume (i.e., trucks, buses and recreational vehicles) exceeds 20 veh/h during the design hour; and

One of the following conditions exists:

- The critical length of grade is exceeded for the 10 mph speed reduction curve (see *Figure 2-23, Critical Length of Grade for Design*), or
- The level of service (LOS) on the upgrade is E or F, or
- There is a reduction of two or more LOS when moving from the approach segment to the upgrade; or
- The construction costs and the construction impacts (e.g., environmental, right-of-way) are considered reasonable.

Multi-lane Highways – A truck-climbing lane should be considered on a multi-lane highway if the following conditions are satisfied:

- The directional service volume for LOS D is exceeded on the upgrade; and
- The directional service volume exceeds 1000 veh/h/lane; and

TDOT ROADWAY DESIGN GUIDELINES – PDN
CHAPTER 2 GEOMETRIC DESIGN CRITERIA

English

Revised:

- One of the following conditions exists:
 - The critical length of grade is exceeded for the 10 mph speed reduction curve (see *Figure 2-23, Critical Length of Grade for Design*), or
 - The LOS on the upgrade is E or F, or
 - There is a reduction of one or more LOS when moving from the approach segment to the upgrade; and
 - The construction costs and the construction impacts (e.g., environmental, right-of-way) are considered reasonably.

Also, truck-climbing lanes should be considered where the above criteria are not met and if there is an adverse crash experience on the upgrade related to slow-moving heavy vehicles.

2-1100.02 CAPACITY ANALYSIS

See the [Highway Capacity Manual 2016](#) for guidance on conducting capacity analyses for climbing lanes on two-lane and multi-lane highways.

2-1100.03 CRITICAL LENGTH OF GRADE

The critical length of grade is the maximum length of a specific upgrade on which a truck can operate without an unreasonable reduction in speed. The highway gradient, in combination with the length of the grade, will determine the truck speed reduction on upgrades.

The following will apply to the critical length of grade:

1. Design Vehicle – *Figure 2-23, Critical Length of Grade for Design*, presents the critical length of grade for a 200 lb/hp truck. This vehicle is representative of size and type of a heavy vehicle normally used for design on main roads.
2. Criteria – *Figure 2-23, Critical Length of Grade for Design*, provides the critical lengths of grade for a given percent grade and acceptable truck speed reduction. Although these curves are based on an initial truck speed of 70 mph, they apply to any design or posted speed. For design purposes, use the 10 mph speed reduction curve in the figure to determine if the critical length of grade is exceeded.
3. Momentum Grades – Where an upgrade is preceded by a downgrade, trucks will often increase their speed to ascend the upgrade. A speed increase of 5 mph on moderate downgrades (3%-5%) and 10 mph on steeper downgrades (6%-8%) of sufficient length are reasonable adjustments to the initial speed. This assumption allows the use of a higher speed reduction curve in *Figure 2-23, Critical Length of Grade for Design*. However, the Designer should also consider that these speed increases may not always be attainable. If traffic volumes are sufficiently high, a truck may be behind another vehicle when descending the momentum grade, thereby restricting the

TDOT ROADWAY DESIGN GUIDELINES – PDN
CHAPTER 2 GEOMETRIC DESIGN CRITERIA

English

Revised:

increase in speed. Therefore, only consider these increases in speed if the highway has a LOS C or better.

4. Measurement – Vertical curves are part of the length of grade. *Figure 2-24, Measurement for Length of Grade*, illustrates how to measure the length of grade to determine the critical length of grade using *Figure 2-23, Critical Length of Grade for Design*.
5. Application – If the critical length of grade is exceeded, flatten the grade, if practical, or evaluate the need for a truck-climbing lane. Typically, only two-lane highways have operational problems that require truck-climbing lanes.

TDOT ROADWAY DESIGN GUIDELINES – PDN
CHAPTER 2 GEOMETRIC DESIGN CRITERIA

English

Revised:

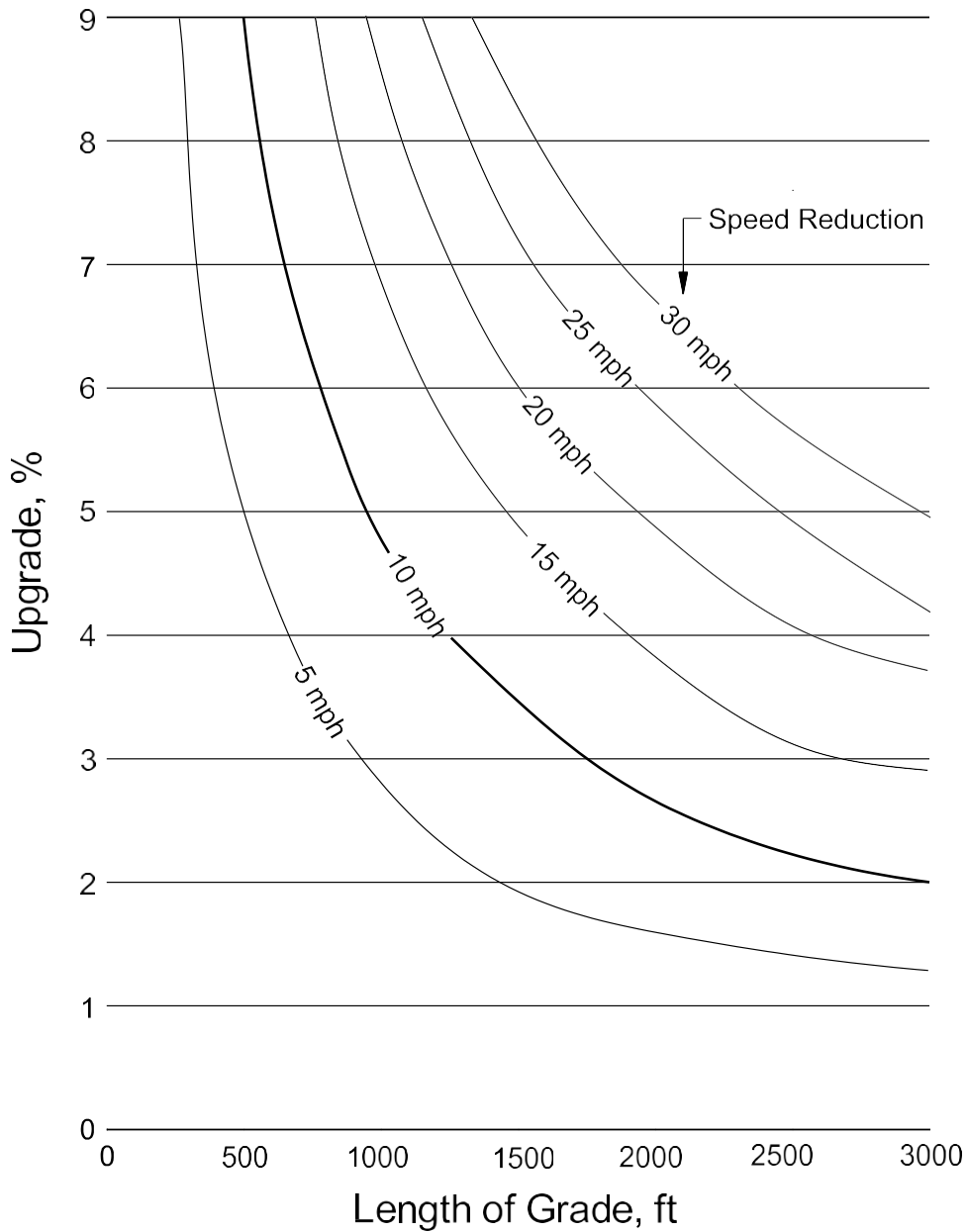

Notes:

1. Typically, the 10 mph curve will be used.
2. Figure is based on a truck with initial speed of 70 mph. However, it may be used for any design or posted speed.
3. This figure is based on a 200 lb/hp heavy vehicle.
4. Figure is from the AASHTO A Policy on Geometric Design of Highways and Streets.

Figure 2-23
Critical Length of Grade for Design

TDOT ROADWAY DESIGN GUIDELINES – PDN
CHAPTER 2 GEOMETRIC DESIGN CRITERIA

English

Revised:

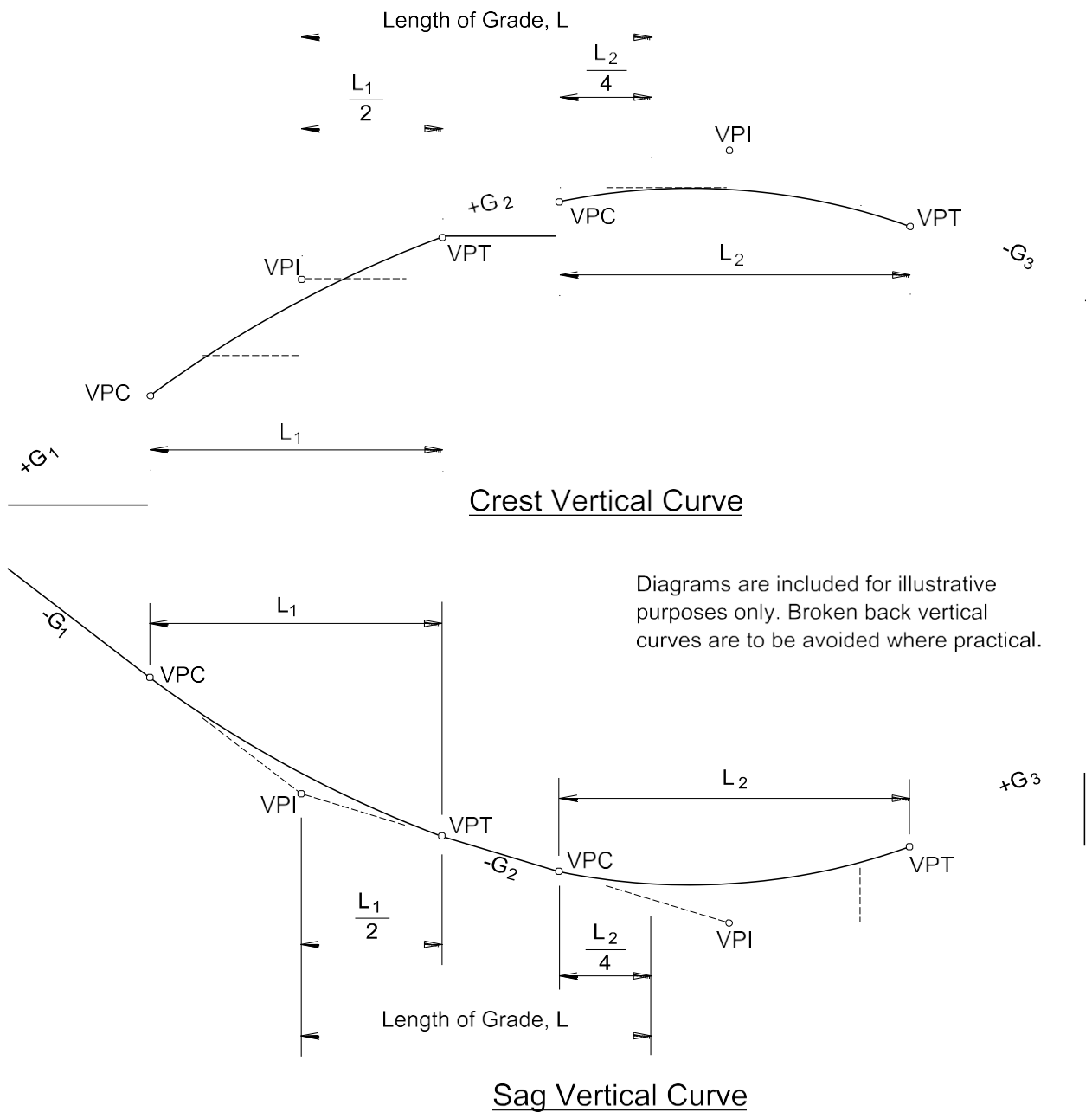

Notes:

1. For vertical curves where the two tangent grades are in the same direction (both upgrades or both downgrades), 50% of the curve length will be part of the length of grade.
2. For vertical curves where the two tangent grades are in opposite directions (one grade up and one grade down), 25% of the curve length will be part of the length of grade.

Figure 2-24
Measurement for Length of Grade

TDOT ROADWAY DESIGN GUIDELINES – PDN
CHAPTER 2 GEOMETRIC DESIGN CRITERIA

English

Revised:

Highway Types – The critical-length-of-grade criteria applies equally to two-lane or multi-lane highways, and applies equally to urban and rural facilities.

Alternative Critical Lengths of Grades – In many design situations, *Figure 2-23, Critical Length of Grade for Design*, may not be directly applicable to the determination of the critical length of grade for one of following reasons:

- The truck population for a given site may be such that a weight/power ratio is either less than or greater than the 200 lb/hp design vehicle (e.g., coal mining trucks, gravel trucks).
- The truck speed at the entrance to the grade may differ from the 70 mph assumed in *Figure 2-23 Critical Length of Grade for Design*.
- The profile may not consist of a constant percent grade.

For these situations, the Designer may want to consider using the software program Truck Speed Profile Model (TSPM) described in [NCHRP Report 505 Review of Truck Characteristics as Factors in Roadway Design](#) to determine the applicable critical length of grade. This program may be used to generate speed truck profiles for any specified truck weight/power ratio, initial truck speed, and sequence of grades.

Example Problems – Examples No. 1 and No. 2 illustrate the use of *Figure 2-23 Critical Length of Grade for Design*, to determine the critical length of grade. Example No. 3 illustrates the use of *Figure 2-23, Critical Length of Grade for Design*, and *Figure 2-24, Measurement for Length of Grade*. In the examples, the use of subscripts 1, 2, etc., indicate the successive gradients and lengths of grade on the highway segment.

Example No. 1

Given: Level Approach
G = +4%
L = 1500 ft (length of grade)
Rural Principal Arterial

Problem: Determine if the critical length of grade is exceeded.

Solution: *Figure, 2-21, Critical Length of Grade for Design*, yields a critical length of grade of 1200 ft for a 10-mph speed reduction. The length of grade (L) exceeds this value. Therefore, flatten the grade, if practical, or evaluate the need for a truck-climbing lane.

Example No. 2

Given: Level Approach

TDOT ROADWAY DESIGN GUIDELINES – PDN
CHAPTER 2 GEOMETRIC DESIGN CRITERIA

English

Revised:

$$G_1 = +4.5\%$$

$$L_1 = 500 \text{ ft}$$

$$G_2 = +2\%$$

$$L_2 = 700 \text{ ft}$$

Rural Arterial with a significant number of heavy trucks

Problem: Determine if the critical length of grade is exceeded for the combination of grades G_1 and G_2 .

Solution: From *Figure 2-23, Critical Length of Grade for Design*, G_1 yields a truck speed reduction of 5 mph. G_2 yields a speed reduction of approximately 3 mph. The total of 8 mph is less than the maximum 10 mph speed reduction. Therefore, the critical length of grade is not exceeded.

Example No. 3

Given: *Figure 2-23. Critical Length of Grade Calculations*, illustrates the vertical alignment on a low-volume, two-lane rural collector highway with no large trucks.

Problem: Determine if the critical length of grade is exceeded for G_2 or for the combination upgrade G_3 and G_4 .

Solution: Use the following steps:

Step 1: Determine the length of grade using the criteria in *Figure 2-25. Critical Length of Grade Calculations*. For this example, the following calculations are used:

$$L_2 = \frac{1000}{4} + 600 + \frac{800}{4} = 1050 \text{ ft}$$

$$L_3 = \frac{800}{4} + 700 + \frac{400}{2} = 1100 \text{ ft}$$

$$L_4 = \frac{400}{2} + 300 + \frac{600}{4} = 650 \text{ ft}$$

Step 2: Determine the critical length of grade in both directions. Use *Figure 2-23, Critical Length of Grade for Design*, to determine the critical length of grade.

- For trucks traveling left to right, enter into *Figure 2-23, Critical Length of Grade for Design*, the value for G_3 (3.5%) and $L_3 = 1100$ ft. The speed reduction is 7.0 mph. For G_4 (2%) and $L_4 = 650$ ft., the speed reduction is approximately 3.5 mph. The total speed reduction on the combination upgrade G_3 and G_4 is 10.5 mph. This exceeds the maximum 10 mph speed reduction. However, on low-volume roads, one can assume a 5 mph increase in truck speed for the 3% “momentum” grade (G_2), which precedes G_3 . Therefore, a speed reduction may be as high as 15 mph before concluding that the combination grade exceeds the critical length of grade. Assuming the benefits of the momentum grade, this leads to the conclusion that the critical length of grade is not exceeded.

TDOT ROADWAY DESIGN GUIDELINES – PDN
CHAPTER 2 GEOMETRIC DESIGN CRITERIA

English

Revised:

-
- For trucks traveling in the opposite direction, on *Figure 2-23, Critical Length of Grade for Design*, enter in the value for G_2 (3%) and determine the critical length of grade for the 10 mph speed reduction (i.e., 1700 ft). Because L_2 is less than 1700 ft (i.e., 1050 ft), the critical length of grade for this direction is not exceeded.

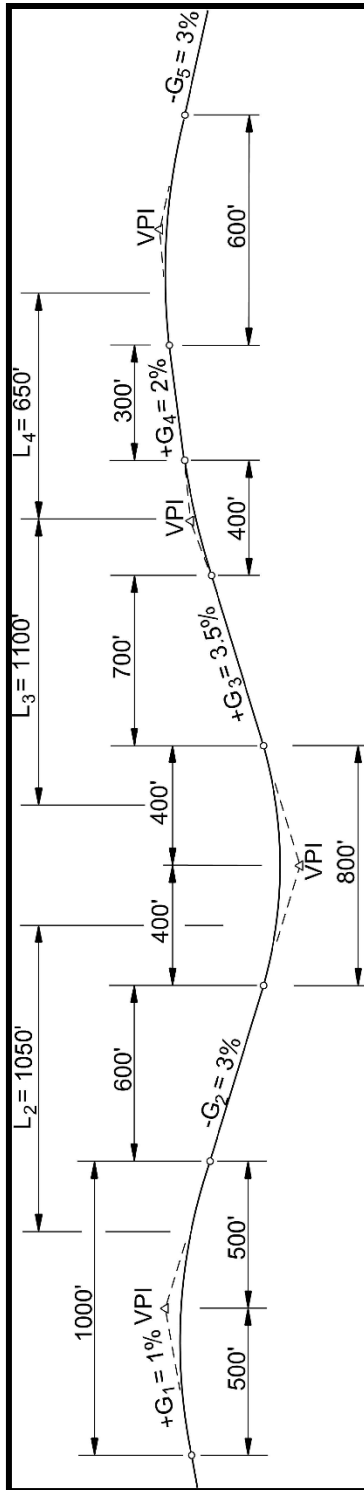

Figure 2-25
Critical Length Of Grade Calculations
(Example No. 3)

TDOT ROADWAY DESIGN GUIDELINES – PDN
CHAPTER 2 GEOMETRIC DESIGN CRITERIA

English

Revised:

2-1100.04 DESIGN CRITERIA

Table 2-8, Design Criteria for Truck-Climbing Lanes, summarizes the design criteria for a truck-climbing lane. Also, consider the following:

1. Design Speed – For entering speeds equal to or greater than 70 mph, use 70 mph for the truck design speed. For speeds less than 70 mph, use the roadway design speed or the posted speed limit, whichever is less. Under restricted conditions, the Designer may want to consider the effect a momentum grade will have on the entering speed. See Section 2-800.03 for additional information on momentum grades. However, the maximum speed will be 70 mph.
2. Cross Slope – On tangent sections, refer to RD11-SE-1 for cross slope information on the truck-climbing lanes.
3. Superelevation – For horizontal curves, superelevate the truck-climbing lane at the same rate as the adjacent travel lane.
4. Performance Curves – *Figure 2-26, Performance Curves for Trucks (200 lb/hp)*, presents the deceleration and acceleration rates for a 200 lb/hp truck.
5. End of Full-Width Lane – In addition to the criteria in *Table 2-8, Design Criteria for Truck-Climbing Lanes*, ensure that there is sufficient sight distance available to the point where the truck, RV, or bus will begin to merge back into the through travel lane. At a minimum, this will be stopping sight distance. Desirably, the driver should have decision sight distance available to the roadway surface (i.e., height of object = 0.0 ft.) at the end of the taper. See the AASHTO *A Policy on Geometric Design of Highways and Streets* for decision sight distance values.

The full-lane width should be extended beyond the crest vertical curve and not ended just beyond the crest of the grade. Desirably the full-lane width should not end on a horizontal curve.

6. Signing and Pavement Markings – Contact the Regional Project Delivery Signing Designer for signing and pavement marking guidance for truck-climbing lanes.

TDOT ROADWAY DESIGN GUIDELINES – PDN
CHAPTER 2 GEOMETRIC DESIGN CRITERIA

English

Revised:

Design Element	Desirable	Minimum
Lane Width	12 ft	Width of adjacent lane
Shoulder Width	Same width as approach shoulder	Interstate: 6 ft Other Highways: 4 ft
Cross Slope on Tangent	0.02 ft/ft	0.02 ft/ft
Beginning of Full-Width Lane ⁽¹⁾	Location where the truck speed has been reduced to 10 mph below the posted speed limit	Location where the truck speed has been reduced to 45 mph
End of Full-Width Lane ⁽²⁾	Location where truck has reached highway posted speed or 55 mph, whichever is less	Location where truck has reached 10 mph below highway posted speed limit
Entering Taper	25:1	300 ft
Exiting Taper	Interstate: 70:1 Other Highways: 600 ft	50:1
Minimum Full-Width Length	1000 ft or greater	Interstate Only: 1000 ft

Table 2-8
Design Criteria for Truck-Climbing Lanes

Notes:

1. Use Figure 2-26, *Performance Curves for Trucks (200 lb/hp)* to determine truck deceleration rates. In determining the applicable truck speed, the Designer may consider the effect of momentum grades.
2. Use Figure 2-26, *Performance Curves for Trucks (200 lb/hp)* to determine truck acceleration rates. Also, see Comment 5 in [Section 2-1100.03](#).

TDOT ROADWAY DESIGN GUIDELINES – PDN
CHAPTER 2 GEOMETRIC DESIGN CRITERIA

English

Revised:

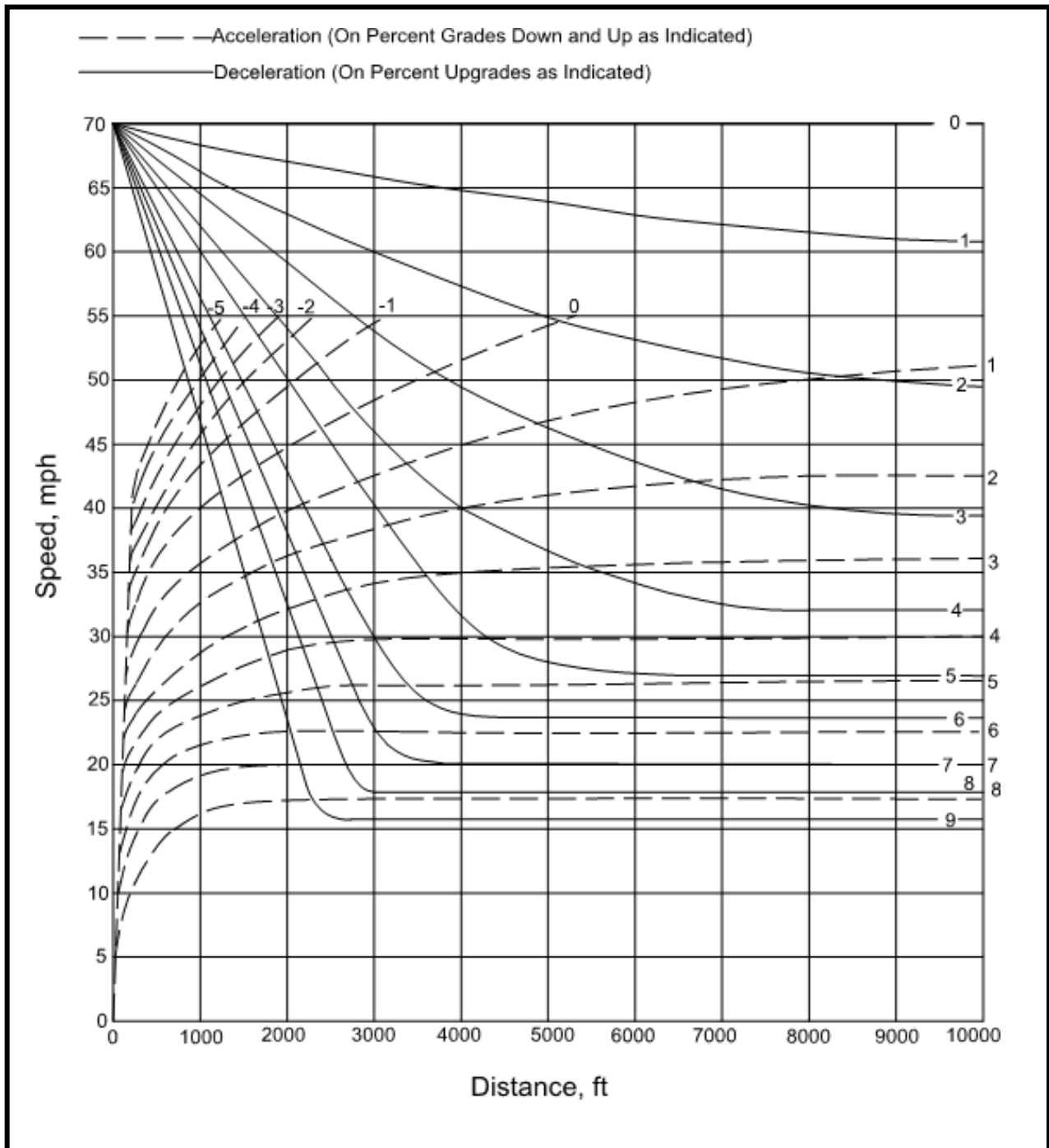

Notes:

1. For entering speeds equal to or greater than 70 mph, use an initial speed of 70 mph. For speeds less than 70 mph, use the design speed or posted speed limit as the initial speed.
2. Figure is from the AASHTO A Policy on Geometric Design of Highways and Streets.

Figure 2-26
Performance Curves for Trucks (200 lb/hp)

TDOT ROADWAY DESIGN GUIDELINES – PDN
CHAPTER 2 GEOMETRIC DESIGN CRITERIA

English

Revised:

2-1100.05 DOWNGRADES

Truck lanes on downgrades are not typically considered. However, steep downhill grades may also have a detrimental effect on the capacity and safety of facilities with high traffic volumes and numerous heavy trucks. Although specific criteria have not been established for these conditions, trucks descending steep downgrades in low gear may produce nearly as great an effect on operations as an equivalent upgrade. The need for a truck lane for downhill traffic will be considered on a site-by-site basis.

2-1100.06 TRUCK SPEED PROFILE

For highways with a single grade, the critical length of grade and deceleration and acceleration rates can be directly determined from *Figure 2-26, Performance Curves for Trucks (200 lb/hp)*. However, most highways have a continuous series of grades. Often, it is necessary to find the impact of a series of significant grades in succession. If several different grades are present, then a speed profile may need to be developed. The following example illustrates how to construct a truck speed profile and how to use *Figure 2-26, Performance Curves for Trucks (200 lb/hp)*.

Example No. 4

Given: Level Approach
 $G_1 = +3\%$ for 800 ft (VPI to VPI)
 $G_2 = +5\%$ for 3200 ft (VPI to VPI)
 $G_3 = -2\%$ beyond the composite upgrade (G_1 and G_2)
 $V = 60$ mph design speed with a 55 mph posted speed limit
 Rural Principal Arterial

Problem: Using the criteria in Table 2-8, *Design Criteria for Truck-Climbing Lanes*, and *Figure 2-26, Performance Curves for Trucks (200 lb/hp)*, construct a truck speed profile and determine the beginning and ending points of the full-width climbing lane.

Solution: Apply the following steps:

Step 1: Determine the truck speed on G_1 using, *Figure 2-26, Performance Curves for Trucks (200 lb/hp)*, and plot the truck speed at 200 ft increments. Assume an initial truck speed of 55 mph. Move horizontally along the 55 mph line to the 3% deceleration curve. This is approximately 2800 ft along the horizontal axis. This is the starting point for G_1 .

TDOT ROADWAY DESIGN GUIDELINES – PDN
CHAPTER 2 GEOMETRIC DESIGN CRITERIA

English

Revised:

Figure 2-27 Distance From VPI₁ (ft)	Horizontal Distance on Figure 2-26 (ft)	Truck Speed (mph)	Comments
0	2800	55	VPI ₁
200	3000	54	
400	3200	53	
600	3400	52	
800	3600	51	VPI ₂

Table 2-9
Truck Speed on G₁

TDOT ROADWAY DESIGN GUIDELINES – PDN
CHAPTER 2 GEOMETRIC DESIGN CRITERIA

English

Revised:

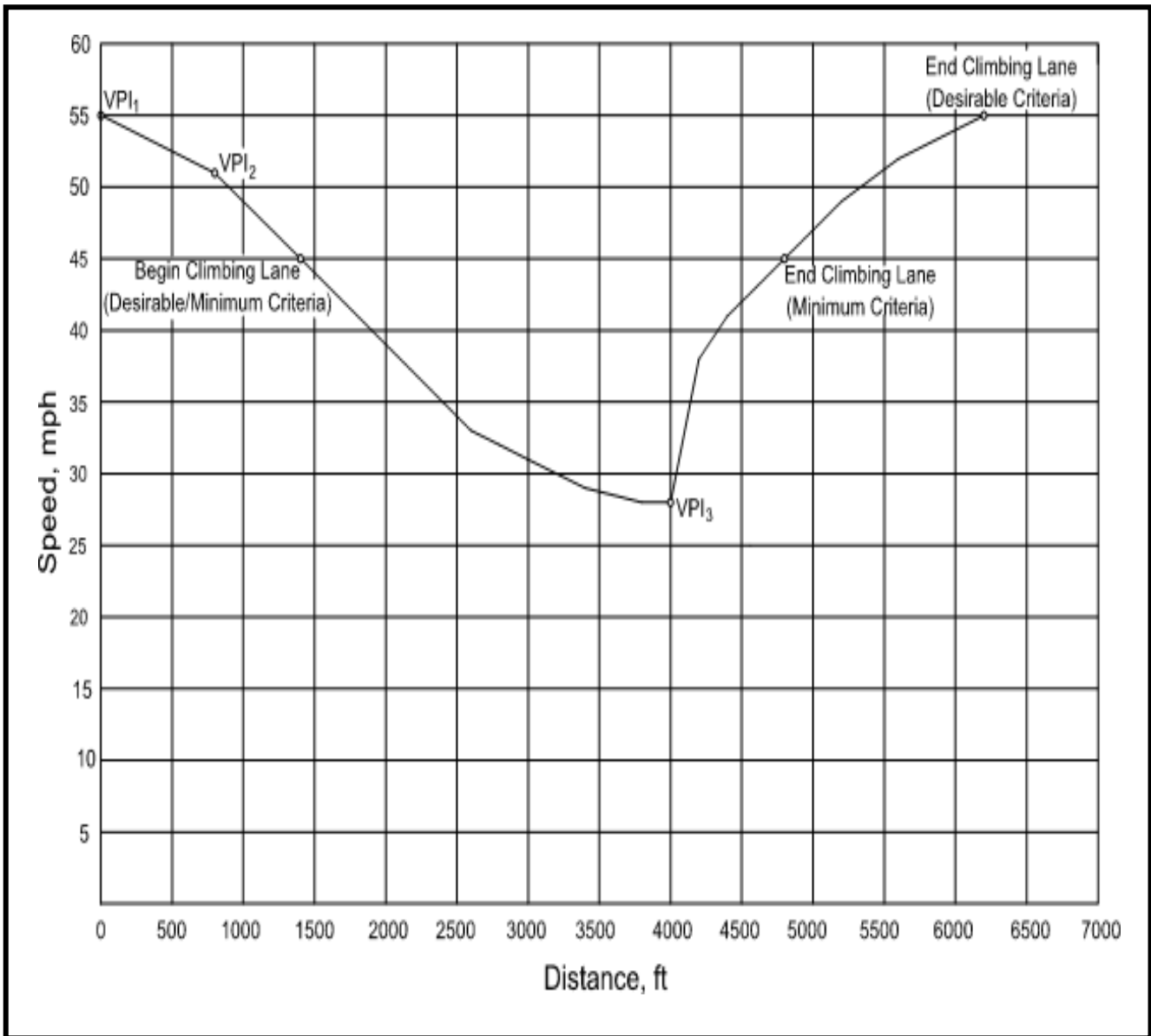

Figure 2-27
Truck Speed Profile

Step 2: Determine the truck speed on G_2 using *Figure 2-26, Performance Curves for Trucks (200 lb/hp)* and plot the truck speed at 200 ft. increments in *Figure 2-27, Truck Speed Profile*. From Step 1, the initial speed on G_2 is the final speed from G_1 (i.e., 51 mph). Move right horizontally along the 51 mph line to the 5% deceleration curve. This is approximately 1900 ft. along the horizontal axis. This is the starting point for G_2 .

TDOT ROADWAY DESIGN GUIDELINES – PDN
CHAPTER 2 GEOMETRIC DESIGN CRITERIA

English

Revised:

Figure 2-27 Distance From VPI ₁ (ft)	Horizontal Distance on Figure 2-26 (ft)	Truck Speed (mph)	Comments
800	1900	51	VPI ₂
1000	2100	49	
1200	2300	47	
1400	2500	45	
1600	2700	43	
1800	2900	41	
2000	3100	39	
2200	3300	37	
2400	3500	35	
2600	3700	33	
2800	3900	32	
3000	4100	31	
3200	4300	30	
3400	4500	29	
3600	4700	29	
3800	4900	28	
4000	5100	28	VPI ₃

Table 2-10
Truck Speed on G₂

Step 3: Determine the truck speed on G₃ using *Figure 2-26, Performance Curves for Trucks*, until the truck has fully accelerated to 55 mph, and plot the truck speed at 200 ft. increments in *Figure 2-27, Truck Speed Profile*. The truck will have a speed of 28 mph as it enters the 2% downgrade at VPI₃. Read into *Figure 2-26, Performance Curves for Trucks*, at the 28 mph point on the vertical axis and move over horizontally to the -2% line. This is approximately 150 ft. along the horizontal axis. This is the starting point for G₃.

**TDOT ROADWAY DESIGN GUIDELINES – PDN
CHAPTER 2 GEOMETRIC DESIGN CRITERIA**

English

Revised:

Figure 2-27 Distance From VPI ₁ (ft)	Horizontal Distance on Figure 2-26 (ft)	Truck Speed (mph)	Comments
4000	150	28	VPI ₃
4200	350	38	
4400	550	41	
4600	750	43	
4800	950	45	
5000	1150	47	
5200	1350	49	
5400	1550	50	
5600	1750	52	
5800	1950	53	
6000	2150	54	
6200	2350	55	

**Table 2-11
Truck Speed on G₃**

Step 4: Determine the beginning and end of the full-width climbing lane. From Table 2-8, *Design Criteria for Truck-Climbing Lanes*, the desirable and minimum beginning of the full-width lane will be where the truck has reached a speed of 45 mph (10 mph below the posted speed). This point occurs 1400 ft. beyond VPI₁.

For ending the full-width climbing lane, the desirable criterion from Table 2-8, *Design Criteria for Truck-Climbing Lanes*, is where the truck speed has reached the posted speed limit (55 mph) or 6200 ft. beyond the VPI₁. The minimum criterion is where the truck has reached a speed of 45 mph (10 mph below the posted speed). This occurs at 4800 ft. beyond VPI₁.

SECTION 12 – STRUCTURAL DESIGN

2-1200.00 CONCRETE BOX AND SLAB TYPE CULVERTS AND BRIDGES

As structures are proposed or changed on projects, the impact to the environment shall be considered. Early consideration for the type of structure and construction of the structure shall be considered, especially when there are restrictions of piers being placed in the water or construction time restrictions. Precast, pre-stressed bridge deck panels will not be allowed to be used on concrete box or slab type culverts.

2-1200.01 TYPE DESIGNATION

For each culvert or bridge, the plans must clearly indicate the type (box or slab) that should be used on the project. The type shall be shown and labeled on the plans along with corresponding quantities as noted in the checklists for each project stage.

The current Standard Drawings for box or slab type culverts or bridges are found in the Standard Structure Drawings. Special or new designs may be requested through the proper channels from the Structures Division.

For all projects having either concrete box and/or slab culverts or bridge projects, the Standard Drawing Index Sheet shall include the appropriate STD-17 series of drawings showing the particular structures that apply to the project.

2-1200.02 PAVED APRON FOR BOX CULVERT AND BRIDGE OUTLETS

A paved apron may be used on concrete box culverts and bridges in selected locations as determined by the Design Manager if requested by the Structures or Construction Division. Standard Drawing STD-17-19 should be used when an apron is required.

The quantities shall be added to the concrete, steel, and foundation fill material quantities for the box culvert or slab bridge. Footnote these quantities to show the amount of concrete and steel bar reinforcement included for the paved aprons, when applicable. The steel bar reinforcement may be computed using a weight of 58 pounds per 100 square feet of apron, plus the weight of the A500 bars (use 3.13 pounds per bar).

2-1200.03 CONCRETE BOX AND SLAB TYPE CULVERTS AND BRIDGES IN SHALLOW FILLS

On concrete box and slab type culverts and bridges where there is little or no fill to be placed on top of the structure and/or there are significant effects on construction due to grades, superelevation or curvature, the Designer shall place information on the plans as follows:

TDOT ROADWAY DESIGN GUIDELINES – PDN
CHAPTER 2 GEOMETRIC DESIGN CRITERIA

English

Revised:

- A. Where the horizontal curvature of the roadway, as opposed to the normally straight nature of the inlet and outlet, is sufficient that the guardrail may encroach on the shoulder and/or roadway (See *Figure 2-28, Potential Guardrail Encroachment*), the Designer shall investigate the need to have the inlet and outlet constructed on a curve parallel to the centerline of the roadway.

If curved inlets and/or outlets are required, a note similar to the one below shall be placed on the culvert section.

"The inlet and outlet ends of the box culvert at Sta. ___ shall be curved parallel to the centerline of the roadway."

- B. Where grades and/or superelevation cause significant effects on construction, the Designer shall show the following additional details and elevations on the culvert drainage section as shown in *Figure 2-29, Box Bridge or Culvert Elevation Details*:

1. Add detail of box showing flow line, top of wall and top of slab adjacent to vertical walls on both inlet and outlet ends.
2. Show elevations of top of curb and top of wingwalls to suit roadway grades and superelevation. The height of curb may vary; but shall not exceed a height of 2.5 feet above the top of the box. In the event this cannot be avoided, the Designer will contact the Hydraulics Section of the Structures Division to resolve the issue.

Provide a cross-section of the roadway on top of the box showing the asphalt paving needed on the box to obtain the roadway grade and proper pavement cross slope. See *Figure 2-30, Typical Cross-Section Information for Box and Slab Type Culverts and Bridges*.

3. Show crown or superelevation when the concrete top slab is to be the riding surface.
- C. Table 2-12, *Adjustment Factor for Estimating Additional Reinforcing Steel Quantities in the Vertical Walls of Concrete Box or Slab Type Culverts or Bridges* to determine the appropriate adjustment factor. (See associated *Figure 2-31, Typical Concrete Box or Slab Type Culvert or Bridge Modification*). The Structures Division will assist the Designer in these calculations, if assistance is requested.
- D. If the top slab is to be used as the riding surface and the design speed is less than 40 mph, the following note shall be added to the plans as a footnote for the concrete item for box bridges.

"Bridge deck finish to be burlap drag in accordance with method "A" as specified in Subsection 604.23 of the *Tennessee Department of Transportation Standard Specifications*."

TDOT ROADWAY DESIGN GUIDELINES – PDN
CHAPTER 2 GEOMETRIC DESIGN CRITERIA

English

Revised:

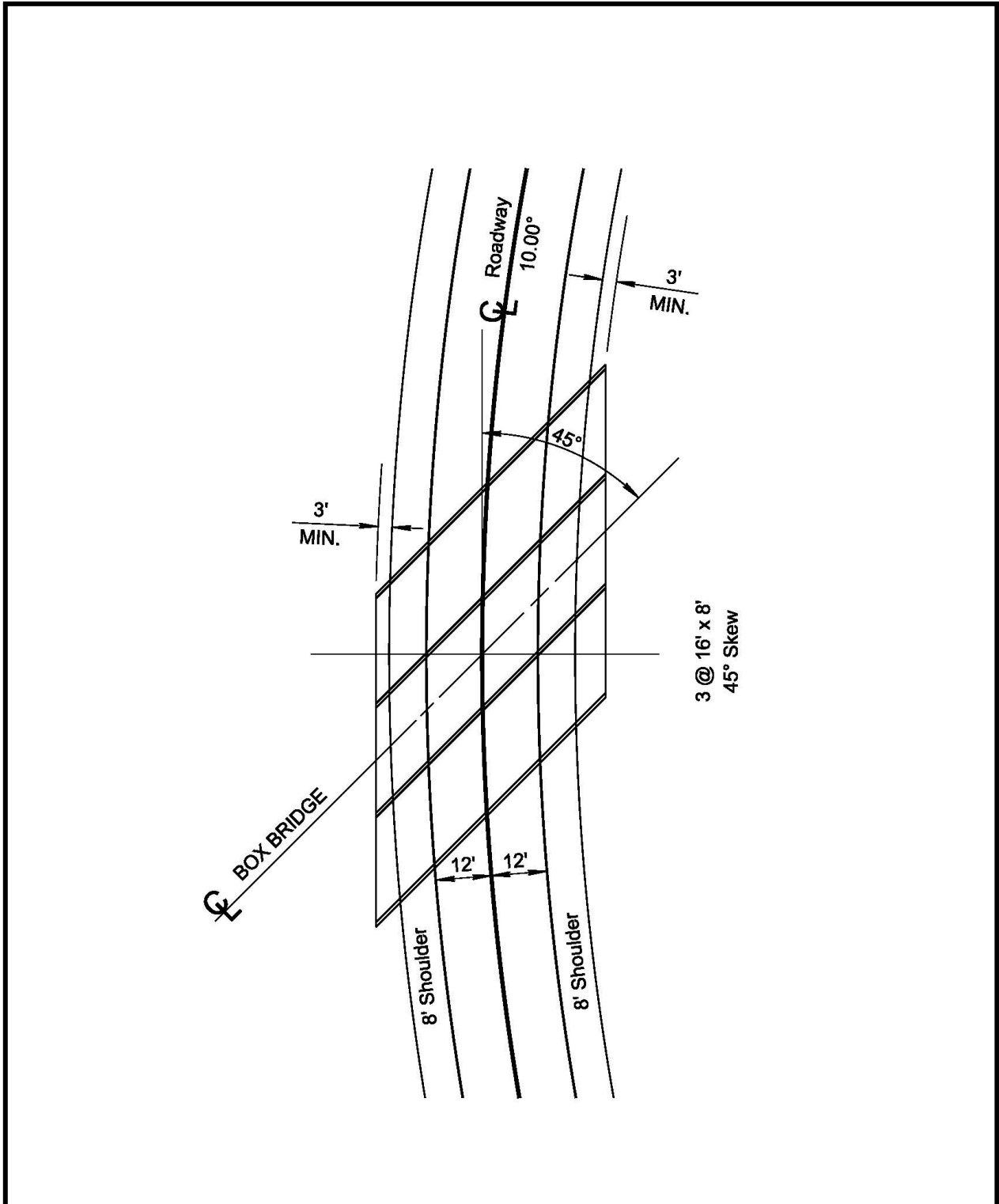

Figure 2-28
Potential Guardrail Encroachment

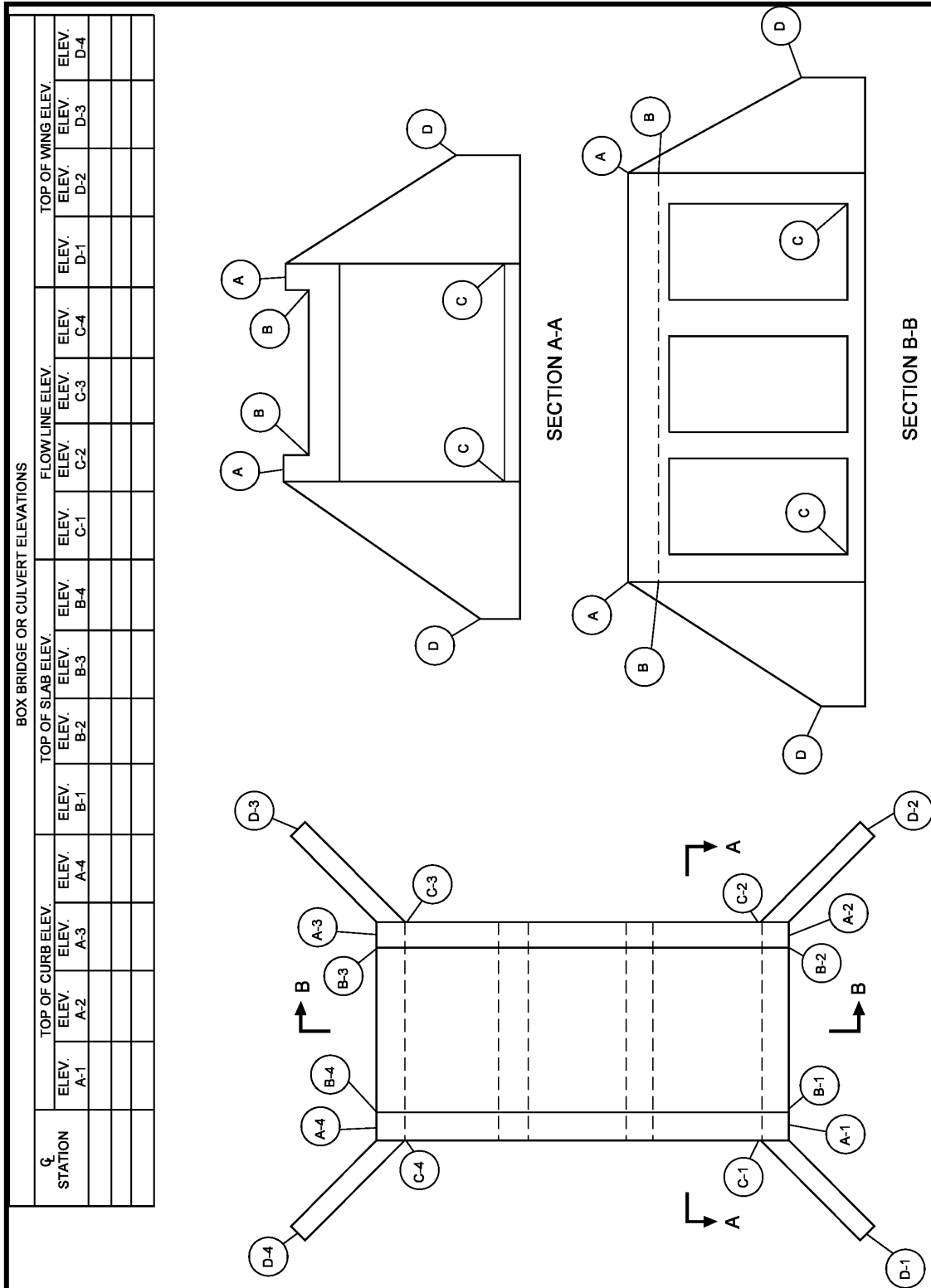

Figure 2-29
Box Bridge or Culvert Elevation Details

TDOT ROADWAY DESIGN GUIDELINES – PDN
CHAPTER 2 GEOMETRIC DESIGN CRITERIA

English

Revised:

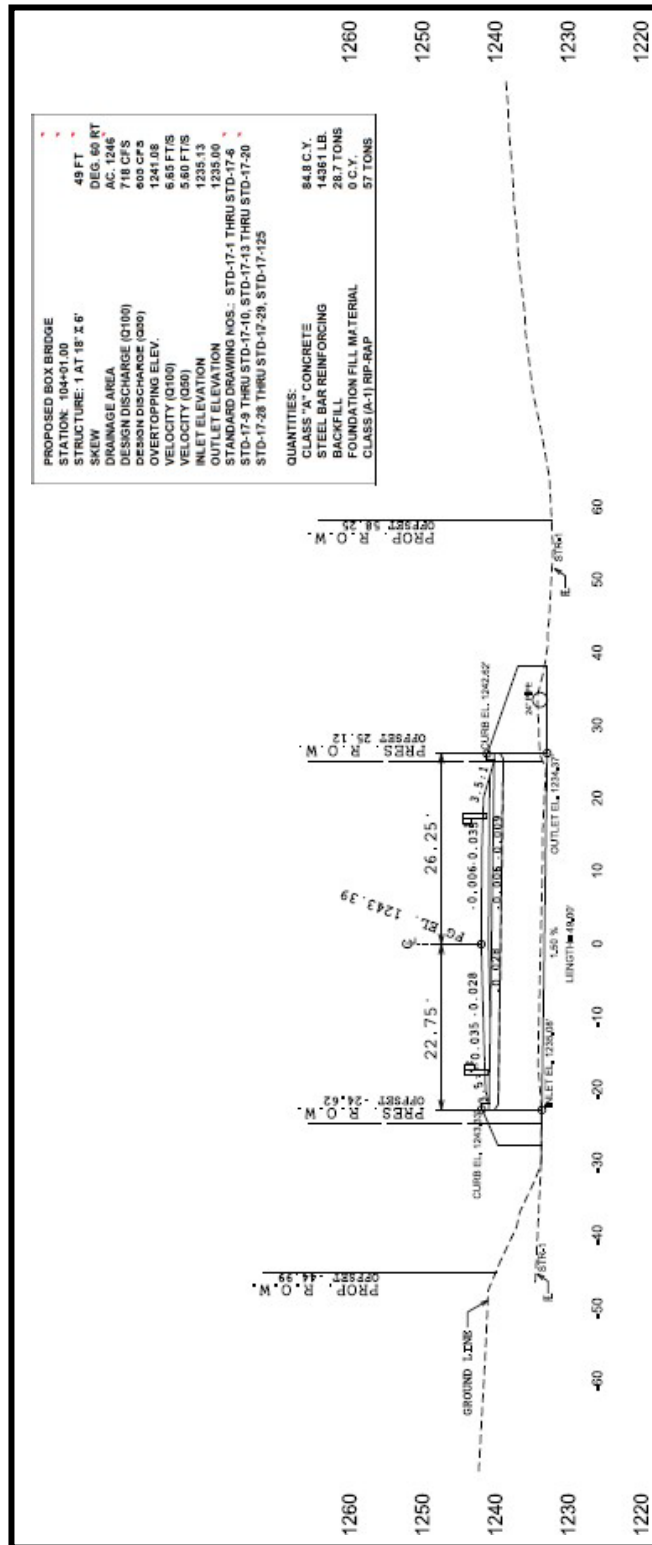

Figure 2-30

Typical Cross-Section Information for Box and Slab Type Culverts and Bridges

TDOT ROADWAY DESIGN GUIDELINES – PDN
CHAPTER 2 GEOMETRIC DESIGN CRITERIA

English

Revised:

ADJUSTMENT FACTOR FOR ESTIMATING ADDITIONAL REINFORCING STEEL QUANTITIES IN THE VERTICAL WALLS OF CONCRETE BOX OR SLAB TYPE CULVERTS OR BRIDGES		
SPAN WIDTH IN FEET	*EXTERIOR WALL IN LB./L.F./V.F.	*INTERIOR WALL IN LB./L.F./V.F.
8	2.27	1.33
10	2.45	1.50
12	2.94	1.71
14	3.94	2.17
16	3.94	2.17
18	3.94	2.17

* ADDITIONAL POUNDS OF REINFORCING STEEL IN VERTICAL WALLS BASED ON POUNDS PER LINEAR FOOT ONE FOOT IN HEIGHT FOR ANY NUMBER OF BARRELS ON ANY SKEW. THIS TABLE IS GOOD FOR AN INCREASE IN WALL HEIGHT NOT EXCEEDING TWO FEET AND FILL HEIGHTS NOT EXCEEDING TWO FEET.

Table 2-12
Adjustment Factor for Estimating Additional Reinforcing Steel Quantities in the Vertical Walls of Concrete Box or Slab Type Culverts or Bridges

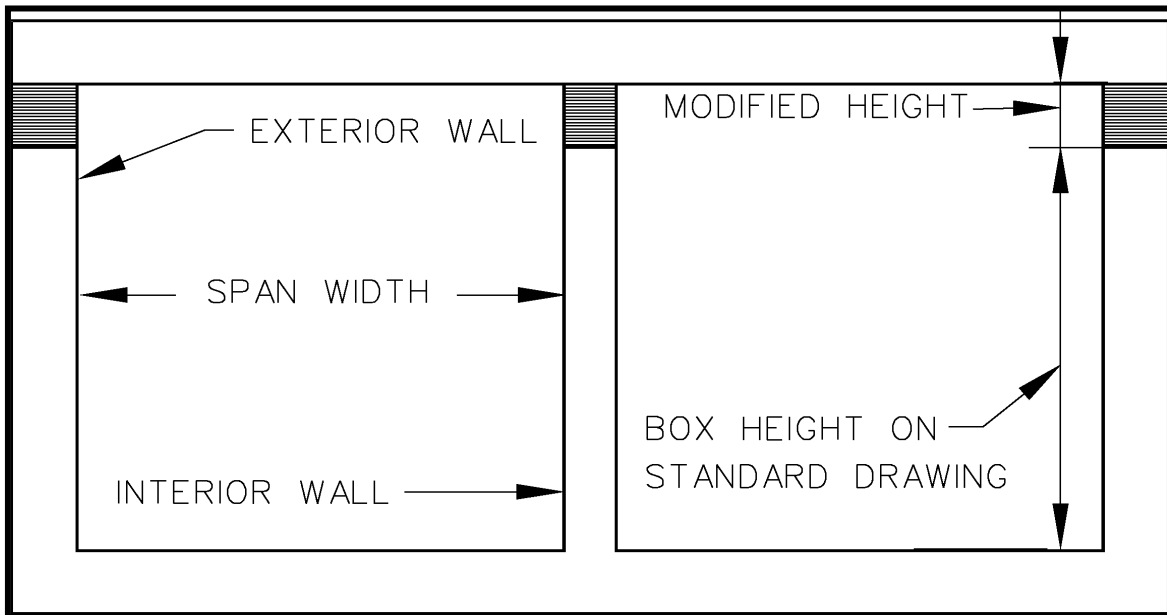

Figure 2-31
Typical Concrete Box or Slab Type Culvert or Bridge Modification

TDOT ROADWAY DESIGN GUIDELINES – PDN
CHAPTER 2 GEOMETRIC DESIGN CRITERIA

English

Revised:

2-1200.04 STEEL BAR REINFORCEMENT (ROADWAY)

On all projects which include reinforced concrete box or slab type culverts or bridges, Standard Drawing STD-9-1, Standard Reinforcing Bar Support Details for Concrete Slabs, shall be listed on the appropriate culvert sheets and in the Structures Standard Drawing index.

If the top slab used on concrete box or slab type culverts or bridges is to be used as a riding surface or has less than 1 foot of fill over it, then epoxy-coated reinforcing steel is to be used in the top mat of the top slab and curbs, including tie bars for curbs and corner bars of the exterior walls. All other steel is to be in the form of black bars. The unit cost bid for Item Number 604-02.02, Steel Bar Reinforcement (Box Bridges), is to include any additional cost for epoxy-coated steel as noted on plans details or Standard Drawings.

If the project has a reinforced concrete deck bridge, STD-9-1 will appear in the bridge index and it will not be necessary to list it again in the roadway index.

2-1201.00 HAUL ROADS

Haul roads are required to provide temporary access to facilitate the movement of equipment and materials on a project site during construction. Haul roads should encroach no further than the top of a stream bank. If access is needed to extend into or across a stream, this is considered a temporary stream crossing and Designers should refer to Standard Drawing EC-STR-25. For clarification purposes, this section is only referring to haul roads and not temporary stream crossings.

2-1201.01 HAUL ROAD DESIGN CONSIDERATIONS

If a stream has Q50 discharge greater than or equal to 500 cfs, the Designer should request that the Hydraulics Section of the Structures Division prepare a hydraulic design of the haul road. Otherwise, Designers are responsible for designing the haul roads. Haul roads shall be shown on the Typical Section, Property Map, Present Layout, ROW Detail, Proposed Layout, Profile, Drainage Map, EPSC, Traffic Control, and Bridge Layout sheets. A separate sheet is not required for the haul road profile but if included with a side road, the sheet name shall be modified to include the haul road.

If the haul roads are strictly to be used for the transport of materials to the construction site, the haul road widths shall be a minimum of 22'-0". If the haul roads are also to be used for the staging of work, the haul road widths shall be increased to 38'-0", which should be adequate for most cranes with lift capacities up to 200 tons. The profile of haul roads above ground shall be at least 12". If the haul roads are to be constructed in a floodplain, the haul road profile shall be at least 12" above the 5-year storm event water surface elevation. The Designer shall seek additional guidance during field reviews from the Headquarters Construction Office and Regional

TDOT ROADWAY DESIGN GUIDELINES – PDN
CHAPTER 2 GEOMETRIC DESIGN CRITERIA

English

Revised:

Operations staff to determine the location and appropriate size of the haul roads. It is recommended to limit extending haul roads more than 25' along a stream top of bank.

2-1201.02 HAUL ROAD COMPENSATION

The cost of supplying and placing all materials for the initial construction of the haul road and cost for removal of the haul road shall be paid under Item Number 203-50 Construction of Haul Road and the unit of measure shall be Lump Sum. The cost for constructing the haul road includes the following items:

- Geotextile (Type IV)(Stabilization)
- ¹Borrow Excavation (Graded Solid Rock)
- ¹Machined Rip-Rap (Class A-1)
- ¹Machined Rip Rap (Class B)
- ¹Machined Rip Rap (Class C)
- ²Mineral Aggregate (Size 57)
- Temporary Drainage Pipe – May not be necessary on all haul roads

¹ If the haul road is constructed in a dry or unsaturated area, Borrow Excavation (graded solid rock) shall be used. If the haul road is constructed in water or in an area within the flood plain, Machined Rip-Rap (Class A-1, Class B, or, Class C) shall be used in place of Borrow Excavation.

² An additional ten (10) percent for Mineral Aggregate is included in Item 203-50. The additional ten (10) percent is for the maintenance of the haul road due to inclement weather events outside the contractor's control.

Item Number 203-50 shall be footnoted as shown below in the Roadway Estimated Quantities sheet:

FOOTNOTE:

ITEM NUMBER 203-50 SHALL INCLUDE GEOTEXTILE (TYPE IV), BORROW EXCAVATION (GRADED SOLID ROCK) OR MACHINED RIP-RAP (CLASS A-1, CLASS B, OR CLASS C), MINERAL AGGREGATE (SIZE 57), AND TEMPORARY DRAINAGE PIPE (IF APPLICABLE). THE MINERAL AGGREGATE INCLUDES AN ADDITIONAL TEN (10) PERCENT FOR MAINTENANCE.

Any item numbers needed for stabilization of the area due to the removal of the haul road shall be paid for separately.

TDOT ROADWAY DESIGN GUIDELINES – PDN
CHAPTER 2 GEOMETRIC DESIGN CRITERIA

English

Revised:

2-1201.03 HAUL ROAD TYPICAL SECTION

The following haul road typical section (see *Figure 2-32, Haul Road Typical Section*) shall be shown and labeled with the appropriate width and depth based on the anticipated function and loads. The typical section shall be revised accordingly for haul roads constructed in a floodplain. The note shall also be shown.

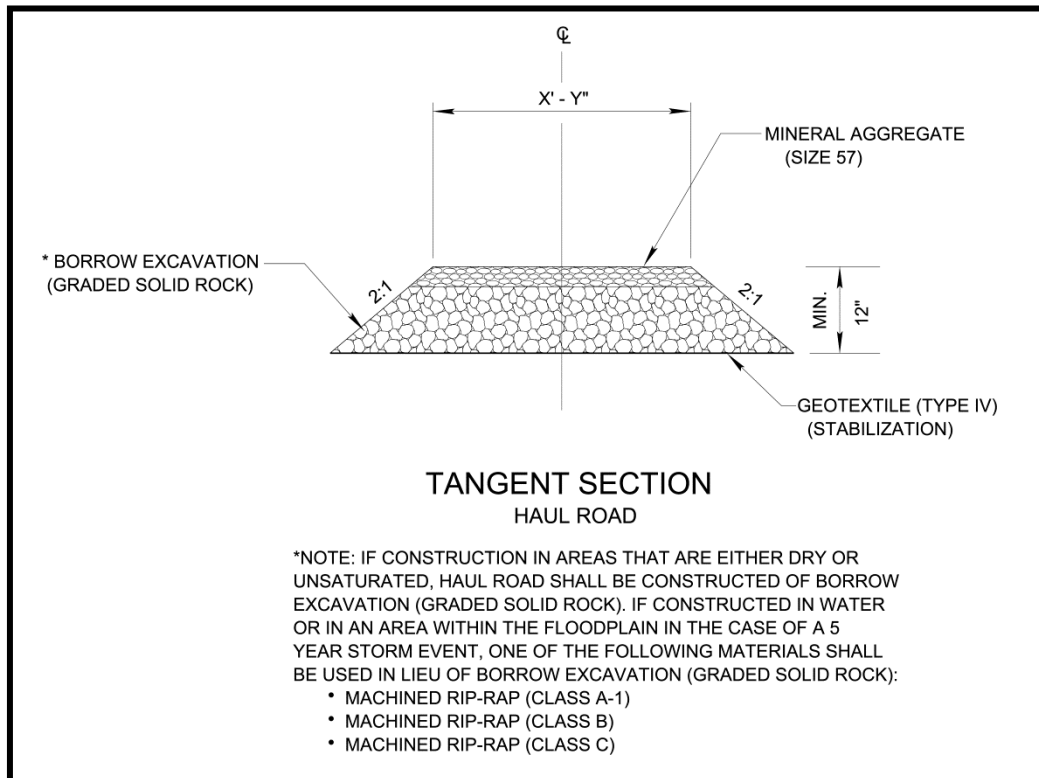

**Figure 2-32
Haul Road Typical Section**

Any changes to the haul road typical section in the field shall be approved by the Regional Operations Engineer. The Regional Operations Engineer shall request a revision from the Designer. The Designer shall check with the Regional Environmental Tech Group to determine if the permit needs to be modified due to the typical section revision.

TDOT ROADWAY DESIGN GUIDELINES – PDN
CHAPTER 2 GEOMETRIC DESIGN CRITERIA

English

Revised:

SECTION 13 - ROUNDABOUT DESIGN

Refer to the [Roundabout Design Reference Guide](#).

TDOT ROADWAY DESIGN GUIDELINES – PDN
CHAPTER 2 GEOMETRIC DESIGN CRITERIA

English

Revised:

SECTION 14 – ROAD RECONFIGURATION AND ROAD DIET

2-1400.00 ROAD RECONFIGURATION

Road Configuration is repurposing the existing available pavement width to improve safety and to accommodate non-motorized users to achieve systemic improvements by modifying roadway geometric design elements (lane width, number of lanes, shoulder width and speed). Road Reconfiguration provides the opportunity to address existing safety issues or multimodal accommodation in an expedited and cost-effective manner by using pavement markings only. Additional information regarding Multimodal Design can be found in the [Roadway Design Guidelines Chapter 3 – Multimodal Design Guidelines](#).

A Road Reconfiguration shall maintain the current Level of Service (LOS) without negatively impacting operational safety of the motorist and non-motorized users (both existing and new). All road reconfigurations must meet TDOT's roadway typical section design standards (Roadway Standard Drawing RD11-TS-Series) or require completion of Design Exception Request or a Design Waiver Request justifying the reason for the deviation. All Design Exception request will be addressed by the Engineering Division as outlined under [Chapter 2-105.00 Design Exception Request](#) and Design Waiver requests will be addressed by the Engineering Division as outlined under [Chapter 2-201.00 Design Waiver Request](#). A Road Reconfiguration request shall be coordinated with local agencies and a local agency coordination letter should be included in the Road Reconfiguration request.

2-1401.00 ROAD DIET

A Road Diet is the reduction of vehicular lanes of an existing four or six lane roadway to a three or five lane roadway to improve safety, and/or accommodate non-motorized users to achieve systemic improvements. Roadway projects identified as a candidate for a Road Diet must be evaluated using the [Road Diet and Road Reconfiguration Request](#) form.

A Road Diet shall maintain a reasonable Level of Service (LOS) without negatively impacting operational safety of the motorist or non-motorized users. Consider whether future LOS will be affected by urbanization which may subsequently change the context, capacity, and performance of an existing rural roadway section. Existing roadway sections functioning at LOS D capacity or worse are not good candidates for a road diet. Any LOS reduction should clearly justify the safety benefits and be included in the [Road Diet and Road Reconfiguration Request](#) form.

TDOT ROADWAY DESIGN GUIDELINES – PDN
CHAPTER 2 GEOMETRIC DESIGN CRITERIA

English

Revised:

2-1402.00 PLANS DISTRIBUTION AND REVIEW PROCESS

All Road Reconfiguration and Road Diet requests shall be submitted by the Team Lead or requesting agency to the Regional Traffic Office. All relevant forms, analyses, and documentation should be included.

The Engineering Division will share the information amongst the committee represented by TDOT Traffic Operations, Engineering Production Support, Multimodal, Long Range Planning, Maintenance, Regional Project Delivery, and Regional Traffic Engineering Offices. This committee will identify whether the geometric design criteria, operational safety impacts, and context elements could be mitigated safely within the existing right-of-way. Requests should be submitted early in the project development process to provide enough time to complete this review. The Team Lead will receive a response and comments from the committee addressing whether the proposed Road Diet could be implemented within the scope of the project or if a separate project with additional planning would be required. The Team Lead or requestor shall keep all reference materials and correspondence in the project folder.

SECTION 15 – DRIVEWAYS

2-1500.00 DRIVEWAYS

A driveway is defined as an improved area leading from a public road to private property. There are three types of driveways: private drives, business entrances, and field entrances. Driveways should be provided for the following:

- A. Where Existing Road is being improved
 - 1. Tie into existing driveway
 - 2. Relocate drive if connection to existing drive is too steep (see Limits of Vertical Grade)
 - 2. Tracts where there is no prior access
- A. New Roadway Construction
 - 1. Provide access to each tract if requested

All driveways on private and public side roads shall be shown on Present, Proposed, Profile, Signing and Marking, and Traffic Control sheets. The following section provides design requirements and considerations when creating a driveway. Designers will be required to add in ROW details for the driveway parcel in COGO. Designers will need to look at the grade sections to develop the correct construction easements. Designers should follow the standard guidance for construction easements of applying 10 ft for urban and 15 ft for rural. See *Figure 2-35, Rural Type Projects Typical Driveway Notation* and *Figure 2-36, Urban Type Projects Typical Driveway Notation* for examples of how to display driveways on plans. For additional information see also, [Manual for Constructing Driveway Entrances on State Highways, 2015](#) and the [Driveway Design Guide](#).

TDOT ROADWAY DESIGN GUIDELINES – PDN
 CHAPTER 2 GEOMETRIC DESIGN CRITERIA

English

Revised:

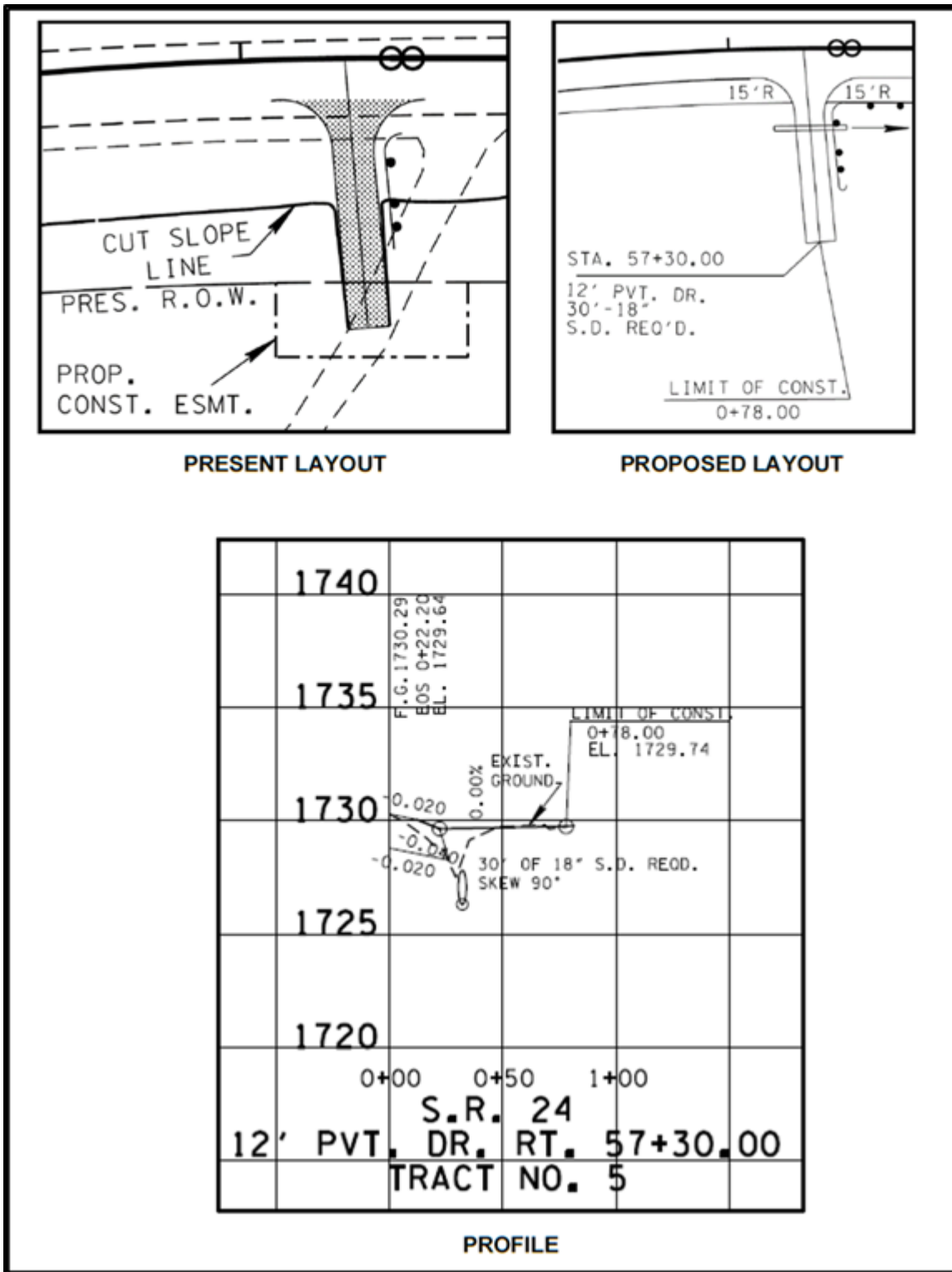

Figure 2-35
 Rural Type Projects Typical Driveway Notation

Note: This figure is for layout procedure purposes only. Please refer to [Manual for Construction Driveway Entrances on State Highways, 2015](#) and Roadway Standard Drawings RP-D-15, RP-D-16 and RP-R-1 for design information.

TDOT ROADWAY DESIGN GUIDELINES – PDN
 CHAPTER 2 GEOMETRIC DESIGN CRITERIA

English

Revised:

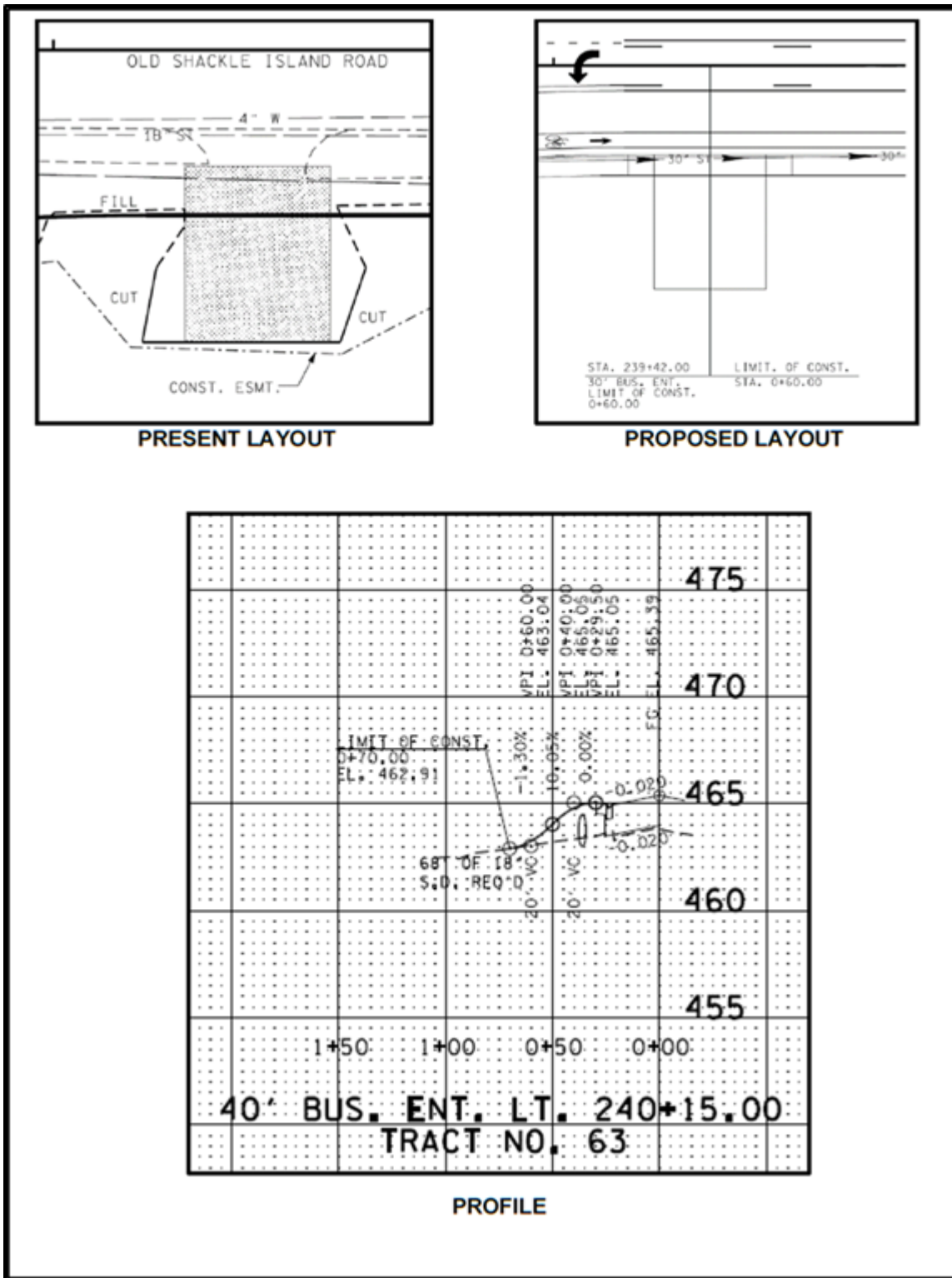

Figure 2-36
Urban Type Projects Typical Driveway Notation

Note: This figure is for layout procedure purposes only. Please refer to [Manual for Construction Driveway Entrances on State Highways, 2015](#) and Roadway Standard Drawings RP-D-15, RP-D-16 and RP-R-1 for design information. .

TDOT ROADWAY DESIGN GUIDELINES – PDN
CHAPTER 2 GEOMETRIC DESIGN CRITERIA

English

Revised:

2-1501.00 DRIVEWAY TYPICAL SECTION AND DESIGN CRITERIA

A new asphalt driveway section should consist of a surface, binder, and a base layer. See *Figure 2-37, Driveway Typical Section*. Where the surface of an existing drive is concrete, substitute 6 inches of concrete for surface and binder and 4 inches for base. Designers shall add a footnote for the Item Number 303-01, Mineral Aggregate, Type A Base, Grading D that notes the quantity used for driveways. When a Designer is connecting into an existing drive, the surface material should match.

If an existing drive is greater than 12 feet in width, the width of the proposed drive shall be equal to the existing width but not greater than the maximum allowable width, typically 40' for commercial. See Roadway Standard Drawing - RP Series for more information.

If an existing drive is gravel, surfacing will be for one shoulder width. The remainder of the drive will be replaced with gravel to the touchdown point.

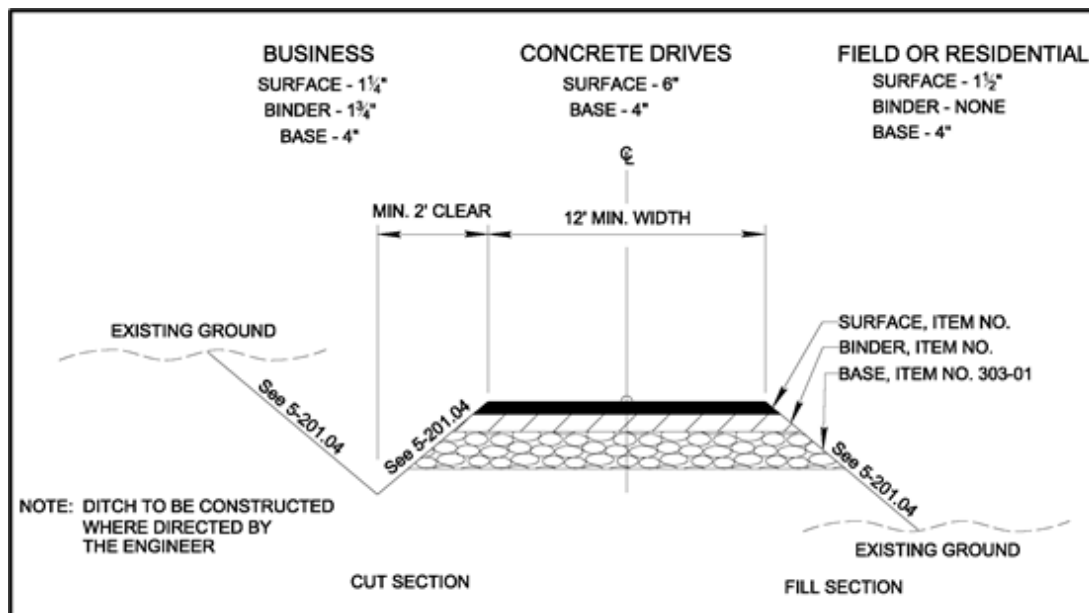

Figure 2-37
Driveway Typical Section

2-1501.01 DRIVEWAY VERTICAL CURVES

Vertical grade limits vary between rural and urban designs, both for private drives and field entrances and for business entrances. See *Table 2-13, Vertical Grade Limits for Rural and Urban Roadways* for maximum vertical grade limits. Vertical curve K values are 1 for a crest curve and 2 for a sag curve. See, Sections 5.3.1 through 5.3.3 of the [Manual for Constructing Driveway Entrances on State Highways, 2015](#) and Roadway Standard Drawing RP-R-1 for additional vertical curve information.

**TDOT ROADWAY DESIGN GUIDELINES – PDN
CHAPTER 2 GEOMETRIC DESIGN CRITERIA**

English

Revised:

Rural Roadways Vertical Grade Limits	
Private Drives & Field Entrances	15% maximum
Business Entrances	8% Maximum
Urban Roadway Design Vertical Grade Limits	
Private Drives and Field Entrances	10% Maximum
Business Entrances	8% Maximum

**Table 2-13
Vertical Grade Limits for Rural and Urban Roadways**

2-1501.02 DRIVEWAY HORIZONTAL CURVES

For private drives, business entrance, and field entrance design on rural roadways, horizontal curve radius limits are 10 ft minimum and 20 ft maximum. For private drives, business entrance and field entrance design on urban roadways, horizontal curve radius limits are 5 ft minimum and 15 ft maximum. See [Manual for Constructing Driveway Entrances on State Highways, 2015](#), Section 5.1.3 and Roadway Standard Drawing RP-R-1 for additional horizontal curve information.

2-1501.03 DRIVEWAY CROSS SLOPE

Positive drainage should be maintained throughout the length of the driveway. One driveway edge may be higher than the other or the center line may be higher than the edges, creating driveway cross slope. Where the driveway and sidewalk intersect, the driveway cross slope is the same as the sidewalk grade.

2-1501.04 DRIVEWAY EDGE

A driveway edge should be clearly defined and visible to all users. The designer should avoid sudden drop-offs along the edge of drive. Fixed objects such as utility poles, fire hydrants, and drainage inlets should be set back from the edge of the driveway and from the edge of the roadway. If there is a side drain and the side drain is within the clear zone, maintain mainline side slopes through the safety endwall. If a parallel side drain is not required, 2:1 slopes may be used beyond the driveway radius. Designers should review the roadway and driveway slopes to ensure that a non-traversable slope within the clear zone is not created when the drop off is five foot or more.

2-1501.05 DRIVEWAY APRONS

Right-of-Way plans for new construction or reconstruction projects shall accommodate the appropriate driveway aprons. The driveway standard drawings have been modified to provide Public Right-of-Way Accessibility Guidelines (PROWAG) compliant cross-slope for sidewalks through driveway aprons. For curb and gutter sections, this typical section is to begin at the back

TDOT ROADWAY DESIGN GUIDELINES – PDN
CHAPTER 2 GEOMETRIC DESIGN CRITERIA

English

Revised:

edge of the proposed or future sidewalk. The aprons have also been modified to provide for a better turning radius into the drive. See Roadway Standard Drawings RP-D-15 and RP-D-16.

2-1501.06 DRIVEWAY SIDE DRAINS

A side drain is a pipe located under a driveway, at the toe of slope in a fill section or in the ditch line in a cut section. The drainage pipe (side drain) shall be a minimum of eighteen inches (18") in diameter. The side drain cover should be 12 inches from the top of pipe to the bottom of the driveway base. Endwalls are required if the drainage pipe falls within the clear zone. The pipe slope should be 0.5% to 2% slope for proper flow. See Roadway Standard Drawings D- SEW-1A, D-SEW-12D, and RP-R-1 for additional information. See the [Driveway Design Guide](#) for side drain calculation information.

2-1502.00 MULTIMODAL ROADWAY DESIGN IN DRIVEWAYS

Multimodal components must be considered when designing driveways. Driveway guidance has traditionally focused on accommodating motor vehicles, but now emphasis is also being placed on managing access and accommodating pedestrians and cyclists. The design of a driveway affects the safety and mobility of motorists, cyclists, and pedestrians. See [Chapter 3 Multimodal Design](#) for additional information for multimodal components.

2-1503.00 GUIDELINES FOR CONSTRUCTION AND RESURFACING OF DRIVEWAYS ON HIGHWAY PROJECTS

2-1503.01 GENERAL

For new construction projects, new driveway entrances shall be located and designed in accordance to the TDOT [Manual for Constructing Driveway Entrances on State Highways, 2015](#) and to the current Roadway Standard Drawings RP-D-series and RP-R-series. For retrofit, resurfacing, and reconstruction projects the designer should leave existing driveway entrances in place if the existing locations do not affect operational safety. It is important to identify potential conflicts during field reviews and have Traffic Operations Division evaluate the potential conflicts. This must be done early in the design process because if an existing driveway entrance needs to be relocated it can affect Right-of-Way acquisition.

DEFINITION OF TERMS

- Paved Shoulder Width - The width of the shoulder paved as part of the project.
- Paver Width - The width of asphalt paving machine used on mainline paving with maximum width of 12 feet or to extend beyond Right-of-Way limit.
- Normal Right-of-Way – The areas of land including the normal slopes of the highway and the public road intersection.

2-1503.02 RESURFACING

TDOT ROADWAY DESIGN GUIDELINES – PDN
CHAPTER 2 GEOMETRIC DESIGN CRITERIA

English

Revised:

- A. Where directed by the TDOT Engineer, the Contractor shall be required to shape public side roads, business entrances, and private drives, as well as clean existing drains before placing materials. All costs are to be included in the price bid for other items of construction.
- B. Resurfacing projects on roadways with shoulders and ditches (no curb or gutter):
 - 1. Private driveways, field entrances, and business entrances will be resurfaced a paver width as a minimum. A pavement taper to transition the new pavement shall be required, it shall be based on an additional 1 foot of width per inch depth of pavement. If the shoulder is narrow enough that the sum of the shoulder and the transition are less than a paver width (lane width), the transition shall occur within the paver width. If the sum of the shoulder and the transition is greater than a paver width, the transition shall occur outside of the paver width.
- C. Resurfacing projects on roadway with urban curb and gutters
 - 1. Residential driveways and business entrances shall have a minimum width of material not less than one foot used in the transition to feather the pavement edge.
- D. In all cases, the length of the pavement transition, the thickness and width of the resurfacing and any additional pavement materials shall be as directed by the TDOT Engineer.
- E. During resurfacing projects, it is the Department's intent to evaluate the repair or installation of curb ramps which meet the PROWAG whenever possible as encountered through resurfacing. See [TDOT Policy Number 530-01](#) for additional information. According to TCA §54-5-202, when resurfacing or performing any maintenance work on a roadway, the Department is responsible for work from "curb to curb". Due to the limited resources of some localities, the Department will attempt to install or repair curb ramps whenever possible. The local government is responsible for maintaining sidewalks, curb ramps, etc.

2-1503.03 NEW OR RECONSTRUCTION

- A. Facilities with Full Access Control
Full access control will be maintained for the entire designated project limits.
- B. Facilities with Limited Access Control
Access will be allowed at public roads and streets only. No driveways will be permitted access to the mainline project.
- C. Facilities with Partial Access Control or Non-Access Control - driveways permitted:
 - 1. Fence Opening: For Partial Access Control facilities, one 50-foot opening in the control access fence will be provided per tract remainder, unless access

TDOT ROADWAY DESIGN GUIDELINES – PDN
CHAPTER 2 GEOMETRIC DESIGN CRITERIA

English

Revised:

is provided from an intersecting road or based on physical conditions and/or conflicts with other design considerations, which prevent an access opening.

2. Existing Driveways:
 - a. For Partial Access Control facilities, one existing paved driveway per tract remainder will be replaced in-kind to a touchdown point. For Non-Access Control facilities, exiting paved driveways will be replaced in-kind to a touchdown point.
 - b. Where the existing driveway is unpaved and the proposed driveway equals or exceeds 7 percent in grade, each proposed driveway will be paved to a touchdown point or until the grade is less than 7 percent.
 - c. Where the existing driveway is unpaved and the proposed driveway is less than 7 percent in grade, each proposed driveway will be paved a shoulder width from the edge of pavement and the remainder of that driveway replaced in-kind to a touchdown point.
3. Requirements for field entrances and/or other driveways:
 - a. New driveways provided in the plans will be paved based on the 7 percent criteria. Those 7 percent or steeper in grade will be paved and those flatter than 7 percent will be covered with base stone.
 - b. Field entrances provided in the plans will be covered with base stone.
 - c. Normally, one field entrance or driveway, whichever is appropriate per tract remainder will be provided except in the following circumstances:
 1. In the project's preconstruction condition, there is a barrier to access such as a substantial cut, fill, ditch or curb.
 2. A non-gated fence where the existing frontage is totally fenced.
 3. In the project's post-construction condition, there is a substantial cut, fill, or ditch.
 - d. Small remainders and damage considerations are to be reviewed by Design Managers and the Right-of- Way Office to determine if a proposed driveway or field entrance is justified. The location, design and method of surfacing of the field entrance or driveway must be in accordance with the previously mentioned Rules. If the landowner does not desire a driveway, then it will not be included in the project.
4. All public roads will be paved to a touchdown point.