

Maintenance Quality Assurance (MQA) Inspection Handbook

Version 1.4



Revised October 6, 2023

CONTENTS

Introduction	3
Conducting the Survey	5
Travel Lanes	7
Paved Lanes – Asphalt	7
Paved Lanes - Concrete.....	8
Paved Shoulders (Rigid or Flexible).....	11
Unpaved Shoulders and Ditches	13
Unpaved Shoulders.....	13
Front / Back Slope	15
Lateral and Outfall Ditches (Unpaved Ditches).....	16
Paved Ditches.....	18
Drainage Structures	19
Curb and Gutter	19
Pipes and Culverts.....	20
Miscellaneous Drainage Structures	23
Inlets.....	24
Roadside.....	25
Turf Condition and Mowing	26
Brush and Trees	28
Roadway Sweeping.....	30
Roadside Appurtenances	31
Guardrail / Cable Rail / Concrete Barrier	31
Impact Attenuators.....	33
Control Access Fence	34
Noise Walls and Retaining Walls.....	35
Graffiti	36
Traffic	37
Ground Signs & Overhead Signs	37

Pavement Markings	41
Words and Symbols	42
.....	42
Object Markers and Delineators.....	43
Glare Screens	45
THRESHOLD CRITERIA TABLES	46
APPENDIX A	55

INTRODUCTION

This handbook defines a method of conducting a visual evaluation of routine highway maintenance conditions. It was developed for use of personnel responsible for conducting the Maintenance Quality Assurance (MQA) Survey. Training for conducting the survey was provided as a part of initiating the MQA program and shall be provided in the future as required. The survey is applicable to all types of highway facilities outlined later in the document.

Using outcome-based maintenance measures and a common Level of Service (LOS) scale such as 0 to 100, the service delivery results can be rated against the established thresholds. The program analysis would be accomplished through the use of periodic statistically valid, random sampling procedures that capture the LOS provided for individual asset features.

A **LOS Rating** is used to determine the existing LOS. Consistent with the practices of peer agencies, TDOT has elected to utilize randomly selected 0.10-mile road segments to evaluate the condition of each feature located within the segment. The evaluations will be based on meeting established “threshold” conditions for each feature/characteristic.

The LOS ratings are carried out by comparing existing field conditions to the threshold value. If the feature/characteristic meets or exceeds the threshold, then it is coded as “PASSED” as it meets the criteria. If it does not meet the criteria, then it is coded as “FAIL”. When the survey is complete, the number of PASSES and FAIL’s are totaled, and a composite number (using a 1 to 100 scale) is produced which represents the level of maintenance currently being provided.

For any given maintenance characteristic, the number assigned as the target LOS represents the percentage of random samples in which the maintenance condition standard corresponding to the activity is to be met or exceeded. For instance, a characteristic with a LOS rating of 83 means that 83 percent of the sample locations met the condition standard.

TDOT’s overall target rating is 80. Each element level should not be below 75. No feature/characteristic should be below a 70.

MQA MANUAL REVISION LOG

Page	Revision	Revised By	Approved By	Date
5	Ramp segment clarification	KM	MQA Committee	6/26/23
7-12	Remove all pavement cracking criteria	KM	MQA Committee	6/26/23
21	Add 'crushed ends' to criteria. NBIS culvert description.	KM	MQA Committee	6/26/23
26	Added description of interstate mowing pattern	KM	MQA Committee	6/26/23
31	Added 'Medium damage' guardrail to criteria	KM	MQA Committee	6/26/23
32	Added guardrail picture	KM	MQA Committee	6/26/23
35	Clarified CA fence w/100 ft minimum.	KM	MQA Committee	6/26/23
37	Deleted 'Lateral Clearance' criteria from signs	KM	MQA Committee	6/26/23
38	Removed 'bracket install' criteria. Added note on breakaway support	KM	MQA Committee	6/26/23
38	Removed lateral clearance chart	KM	MQA Committee	6/26/23
41	Reword striping criteria	KM	MQA Committee	6/26/23
42	Deleted pavement marker criteria	KM	MQA Committee	6/26/23
43	Edited delineators lean to 45 degrees	KM	MQA Committee	6/26/23
44	Noted evaluation criteria only applicable to ramps.	CD	MQA Committee	6/26/23
46	Updated performance Criteria Tables	KM	MQA Committee	6/26/23
13	Unpaved Shoulder edited to 3" and note for under GR.	KM	MQA Committee	9/06/23
20	Changed 25% blockage to 50% for pipes, misc drainage, inlets	KM	MQA Committee	9/27/23

37	Added Sign retro standard to Interstate and NHS roadways	KM	MQA Committee	10/5/23
----	--	----	---------------	---------

CONDUCTING THE SURVEY

TDOT will produce random samples of roads in each Region to be reviewed and inspected. These samples are compiled by using the sampling equation on page 21 from the NCHRP Report 422, Maintenance QA Program Implementation Manual.

A MQA survey team will be composed of a minimum of two people. The MQA survey team's first responsibility is required to be the safety of pedestrians, motorists, and themselves. All surveys are to be conducted at a safe distance from the travel lanes on the outside shoulder of the roadway. On occasion, it may be necessary to schedule the survey of samples with high traffic density during low traffic periods to provide proper safety. It may become necessary to request a safety crew (flag persons, cones, signs, flashing directional arrow boards, etc.) for the maintenance area in which the survey is taking place. The survey team shall walk together on the same side of the street, facing traffic, as they evaluate each sample. The survey team is safer facing traffic as they can observe approaching vehicles. Walking together, the survey team is less likely to miss items that could be missed by a single surveyor, permitting more accurate measurements.

The data collected by the survey team should be recorded on the data base system in a timely manner. All data should be entered completely and accurately.

If the randomly selected segment is under construction, select one of the nearest alternate segments. If the segment is located along a bridge or railroad track, the survey team will skip over the bridge or rail track and then the segment continues after the bridge or tracks.

At the beginning of the survey, the current segment's beginning and ending mile points along with the site number should be recorded and marked. This ensures the segment can be relocated if it needs to be revisited because of data problems.

Ramp segments should be rated from the beginning of the painted gore area to the end of the segment. The deceleration and acceleration lanes are rated with the mainline segments and not evaluated with the ramp.

EQUIPMENT AND SUPPLIES

The following is a list of equipment and supplies for the efficient and safe collection of the survey data:

Copy of MQA Handbook

Agency approved safety vest

Flashing amber lights for vehicle roof

Sample point marking material (e.g. paint, reflective tape)

Measuring wheel

Measuring tape (50 ft. or more)

Straightedge (5 ft. to 8 ft.) (metal or wood)

Min. 4-foot level

Range pole or level rod capable of extending 16.5 feet

String line (100 ft. or more)

Hammer

Probing rod

Binoculars

Mobile data collector

Other publication as needed (e.g. Design Standards, TDOT Roadside Safety Field Guide 2014, MUTCD, etc.)

GENERAL NOTES

- Rate all directional sample points from center of median to right-of-way.
- Rate all other sample points from available right-of-way to right-of-way limits.
- Rate only those items maintained by TDOT being evaluated.
- A directional roadway sample is 1/10 mile or 528 feet in length.
- Exclude all bridge structure elements, i.e. bridge deck, parapet walls, substructure and superstructure.

TRAVEL LANES

Paved Lanes – Asphalt

Desired Outcomes: Safe, durable, smooth

Evaluation Standard:

1. No Potholes greater than six (6) inches in diameter and 1.25 inches or greater in depth or no permeable base exposed.
2. No more than 50 cumulative feet of unsealed longitudinal joints larger than 0.25 inches.

Definitions:

Pothole – These are commonly bowl-shaped holes in the pavement that usually form in low areas, such as wheel paths and utility trenches. They are caused by pavement weaknesses on the pavement surface or within the base, or a loss of load support by either base or sub grade.

Evaluation Procedure:

Potholes: High traffic volume makes the travel lanes inaccessible to safely measure. DO NOT TAKE MEASUREMENTS IN THE TRAVEL LANES! Generally, pothole size can be estimated at a safe distance from the shoulder. For a six-inch diameter estimate, compare the pothole to the size of your hand. Any pothole larger than a hand with fingers extended will likely not meet the desired threshold condition.



Pothole examples - greater than 6 inches in diameter and 1.25 inches deep, failing the criteria.

Paved Lanes - Concrete

Desired Outcomes: Safe, durable, smooth

Definitions:

Pothole – These are commonly bowl-shaped holes in the pavement that usually form in low areas, such as wheel paths and utility trenches. They are caused by pavement weaknesses on the pavement surface or within the base, or a loss of load support by either base or sub grade.

Spalling – Cracking, breaking, or chipping of slab edges.

Joint Seal Damage – Condition which enables materials or water to infiltrate the joint. Also, includes extrusion, hardening, adhesive failure, cohesive failure or complete loss of sealant.

Evaluation Standard: Concrete paved lanes do not meet the maintenance standards when any of the following criteria are not met:

1. No potholes greater than 6 inches in diameter and 1.25 inch or greater in depth.
2. No more than 25% of the joint material is missing or detached.
3. No more than 10% of the surface area with spalling greater than 1 inch deep.
4. No vertical deviation (settlement or heaving) greater than 1 inch in depth.

Evaluation Procedure:

Unsealed Joints and Cracks: Determine the total number of slabs within the evaluation area. Then determine the number of slabs that have unsealed joints. Divide the number of slabs with unsealed joints by the total number of slabs within the evaluation area to determine the percentage of slabs with unsealed joints. If this percentage is more than 25%, then this characteristic does not meet desired maintenance conditions.



Example: Vertical deviation

Vertical Deviation: Observe for unrepaired joint blowups or slab breakage or cracking resulting in 1 inch or greater vertical differentiation with the adjoining slab.

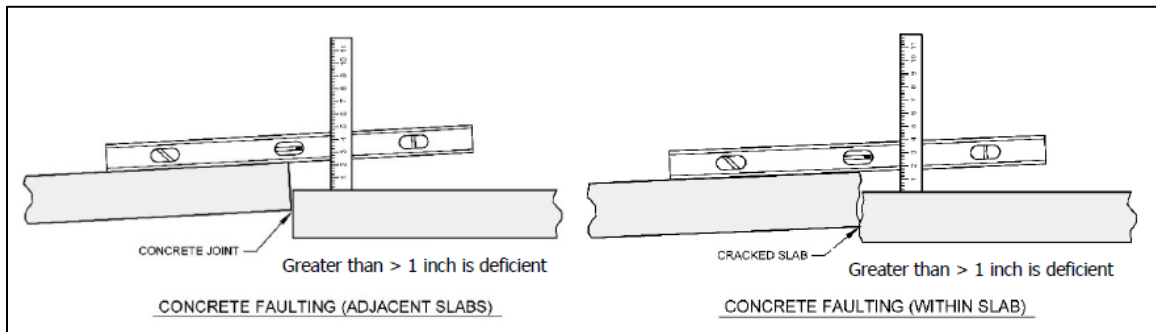

Vertical Deviation – Measurement should be taken as close to the fault as possible

Potholes: Measure the size of the pothole. For all inaccessible high traffic areas, estimate the size of the pothole from the shoulder using your outstretched flared hand as a guide. From the tip of your finger to your wrist is approximately 6 inches.

Joint Seal Damage - Determine the length of the joints in the sample section. Any cumulative length of unsealed joint that exceeds 25% of the total length of all joints in the sample section does not meet the desired maintenance condition.

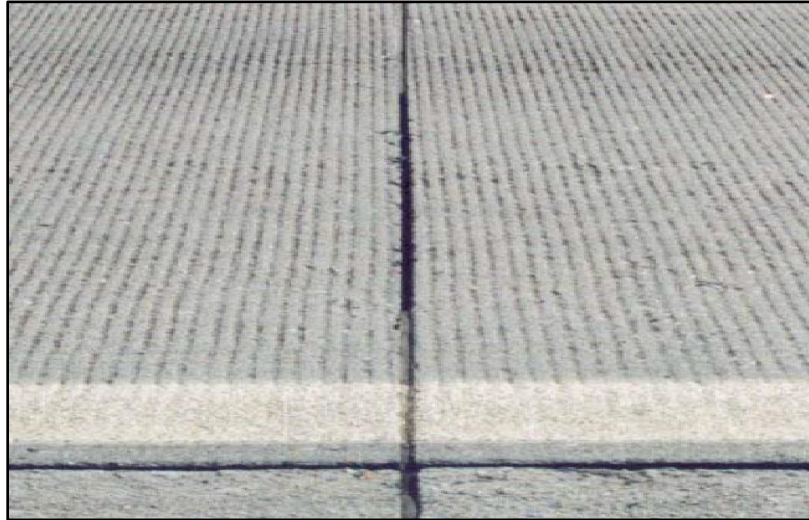

Joint Seal Damage – example of missing joint sealant

Paved Shoulders (Rigid or Flexible)

Desired Outcomes: Safe, smooth

Definitions:

Pavement Edge Drop-off – Occurs when the elevation of the paved shoulder is lower than the elevation of the travel lane. A pavement edge drop-off can result in an unsafe recovery in the event a vehicle leaves the travel lane.

Pothole – These are commonly bowl-shaped holes in the pavement that usually form in low areas, such as wheel paths and utility trenches. They are caused by pavement weaknesses on the pavement surface or within the base, or a loss of load support by either base or sub grade.

Detrimental Transverse Settlements or Heaving – Transverse settlements and heaving is the lateral or longitudinal movement of flexible roadway surface. Severe movement will result in cracking or breaking of the surface exposing the underlying roadway course or the base material.

Evaluation Standard: Paved Shoulders (Rigid or Flexible) do not meet the maintenance standards when any of the following criteria are not met:

1. No potholes greater than 6 inches in diameter and 1.25 inch or greater in depth.
2. No more than 50 continuous linear feet of the rumble strips are missing, filled with debris, or damaged in a manner rendering them ineffective.
3. No travel-lane edge differentiation greater than 2" for 25 continuous feet or greater than 4" at any location.
4. No settlements or heaving greater than 2 inches.
5. No more than 25% of the joint material (Between lane and shoulder) is missing or detached.

Evaluation Procedure:

Many roadways have combinations of paved and unpaved shoulder widths. The Paved Shoulder methods of measuring for evaluating Paved Shoulders are the same as for Paved Lanes. For condition measures purposes, Paved Shoulder evaluation is limited to shoulder widths of 2 feet or greater.

Inspect as a paved shoulder when:

- It is marked as a bicycle lane.



Paved Shoulder Drop-off – example of drop-off from rigid pavement travel lane to flexible paved shoulder

- Within median crossovers for divided highways.
- Areas of on-street parking.
- Gores on the interstates.

Do not inspect:

- Business entrances and commercial driveways as paved shoulders.
 - Paved residential driveways or bulb-outs for mailbox pull-offs if there is not paved shoulder already present.
-

UNPAVED SHOULDERS AND DITCHES

Unpaved Shoulders

Desired Outcome: Smooth with Deteriorated Areas Properly Repaired

Definitions:

Unpaved Shoulder – Unpaved shoulders are generally designed for a six-foot width (but may often be less) and slope at $\frac{3}{4}$ inch per foot (6.25% slope) away from the pavement edge except in superelevated curves.

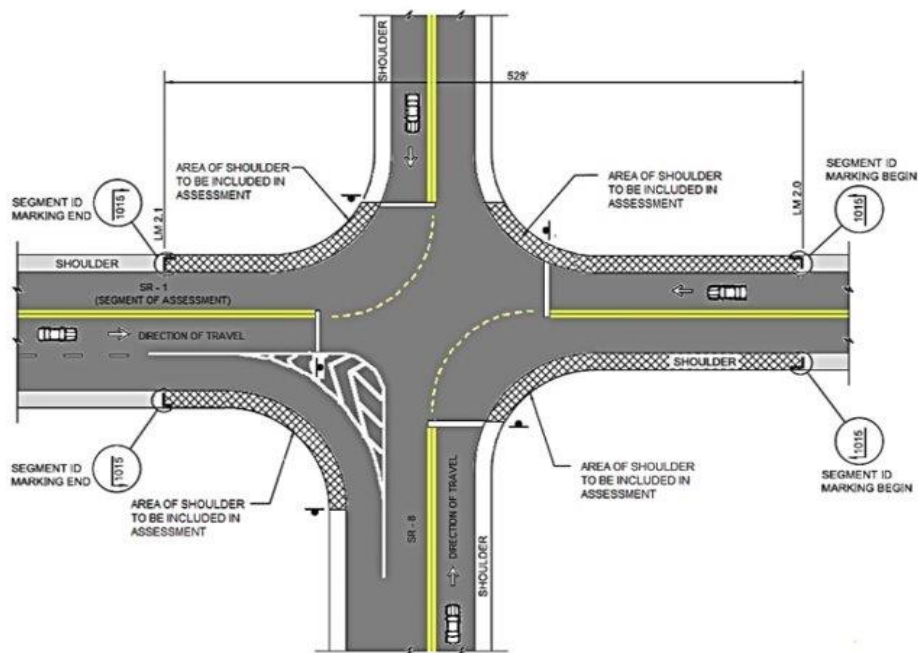

Evaluation Standard:

1. No drop-offs greater than 3" within one foot (1') of the edge of pavement for 25 continuous feet or 100 cumulative feet, or 6 inches anywhere along the shoulder template.
2. No shoulder build-up exceeds 3 inches across the design template for 25 continuous feet.

Quantify LF of failure in notes.

Evaluation Procedure:

To measure a shoulder drop-off, place a *level* on the pavement and measure down. If there is an unpaved shoulder in conjunction with a paved shoulder present, the first two feet adjacent to the paved shoulder should be rated as unpaved shoulder. This applies

to the inside and outside paved shoulder. If there is no defined shoulder, rate drop-off from the edge of pavement. NOTE: The three-inch drop-off criteria does not apply in the presence of guardrail overtop the shoulder edge. All other criteria are still in effect.



Examples: Shoulder drop-off exceeding 2 inches within 1 foot of pavement edge for 25 continuous feet.



Examples: Any shoulder drop-off exceeding 4 inches.



Examples: Shoulder build-up that could cause pooling water.

Front / Back Slope

Desired Outcome: Stable with Minimal Erosion, No Erosion Showing a Pattern that will Endanger Slope Stability

Definitions:

Front Slope – Front slopes provide a gradual and contoured transition from the shoulder edge to the roadside ditch or toe of slope in a fill section.

Back Slope – Back slopes provide a gradual and contoured transition from the roadside ditch to the top of slope in a cut section.

Evaluation Standard:

1. No erosion greater than 6 inches in depth.

Evaluation Procedure:

Survey the sample point for deviations which may include ruts, washouts, and/or buildups. Any deviation greater than 6 inches does not meet desired maintenance conditions. Front slopes are evaluated from the shoulder edge to the roadside ditch bottom, to edge of slope in a fill section, or to the limits of the right-of-way. It is often easier to spot a washout as viewed from the toe of the slope looking up the slope.



Examples: Slope with > 6-inch deviation in depth.

Lateral and Outfall Ditches (Unpaved Ditches)

Desired Outcome: No blockage or erosion

Definitions:

Lateral / Roadside Ditch – Generally, a standard roadside ditch is designed to a minimum depth below the roadway; although, there will be special ditches or exceptions on some older roadways. A roadside ditch must have a front slope and at least a 6-inch back slope to be considered a ditch.

Typical Cross Section

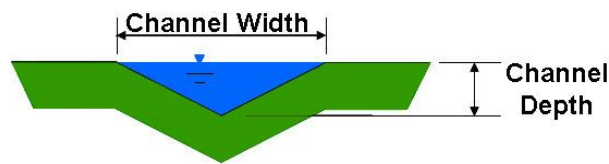

Evaluation Standard:

1. No more than 50 cumulative linear feet of ditch with >50% of the depth of cross-sectional area blocked, or any single blockage of 100%.
2. No erosion greater than 1 foot below original ditch line.

Evaluation Procedure:

Determine if the ditch has a front slope and at least a 6-inch back slope. If it does, then rate the sample for lateral / roadside ditch. If there is no backslope present, then do NOT rate the sample for lateral / roadside ditches unless a roadside pipe, cross-drain pipe or outfall ditch are observed adjacent to the roadway gradient. Observation of the ditches throughout the section should provide insight as to the original design of the ditches. If no ditch is formed but flow still provides positive conveyance away from the pavement, then the drainage is probably functioning as intended (do not rate the sample for lateral ditch).

Each ditch in the segment is to be evaluated. Once a ditch's design shape is determined, check whether any blockage occurs that is 50% or higher from the ditch invert. The elevation of the outside edge of roadway will be used to determine the depth of the ditch. A surveyor's handheld level and folding rule or string line level can be used to make measurements along the sample. The structures in the adjacent to the ditch can be used to determine the design flow line. The general function of the roadside ditch can also be determined by observing the roadside pipes for siltation and obstruction. Sediment obstruction may result in the growth of objectionable vegetation within the ditch area.

Any rock check dams left behind by construction activity may not necessarily present a failure unless the rock check is silted or capturing other debris with 50% or more cross-sectional area blocked.



Examples: Left - Ditch with less than 50% blockage. Right – Ditch with greater than 50% blockage.



Material blocking this paved ditch is greater than 50% of the ditch depth.

Paved Ditches

Desired Outcome: No blockage or erosion

Definitions:

Paved Ditches – This characteristic applies to all urban and rural roadways and paved ditches on urban limited access roadways. Because ditches are constructed to collect and disperse surface water in a controlled manner, they are often paved to prevent erosion or to increase velocity. A proper lining helps increase water flow velocities, and it prevents loss of roadbed support by stabilizing the soil. Ditch erosion can not only impact road stabilization and contaminate natural drainage areas, it can also be a safety problem for errant motorists.

Evaluation Standard:

1. No more than 50 cumulative linear feet of ditch with >50% of the depth of cross-sectional area blocked, or any single blockage of 100%.
2. No undermining or erosion is present at either end or along the parallel edges that exposes any soil area beneath the paved ditch and threatens the structural integrity.
3. No settlement or misalignment greater than 2 inches.
4. No more than 10% of the surface area has cracking exceeding 0.5 inches in width.

Evaluation Procedure:

Review paved ditch for undermining at the approach and trailing end and along the parallel edges. Any erosion that has compromised the structural integrity will cause this characteristic to not meet the desired maintenance condition.

Surface cracking measured at ½ inch or greater over more than 10% of the sample section does not meet the desired maintenance condition.



Example: Paved ditch with >50% of depth blocked by debris for 50 continuous feet.



Example: Not a paved ditch, but example of undermining of a paved slab.

DRAINAGE STRUCTURES

Curb and Gutter

Desired Outcome: No settlement, damage

Definitions:

Curb and Gutter – This characteristic applies to all TDOT roadways and streets with concrete curbing. It also applies to valley gutter and other curbing in subdivision areas. Do not rate curb inlet throats. In areas with curb and gutter as well as sidewalk, rate only to the back of curb and not any portion of the sidewalk. An obstruction in the gutter may divert water flow onto the traveled way and cause vehicle hydroplaning.

Evaluation Standard:

1. No Settlement greater than 2 inches
2. No Misalignment greater than 2 inches
3. No Structural damage is present.

Note: Any unsealed cracking that is $\frac{3}{4}$ inches or greater on 10% of the cumulative length is considered structural damage.

Evaluation Procedure:

Review any and all curb and gutter along the parallel roadway: standard urban curb, valley gutter, freeway curb, asphalt curb sections. Measure the depth of any settlement and misalignment at the joints. If the settlement or misalignment is more than the allowed threshold of 2 inches, it does not meet desired maintenance conditions.



Misalignment greater than two inches does not meet the MQA threshold.

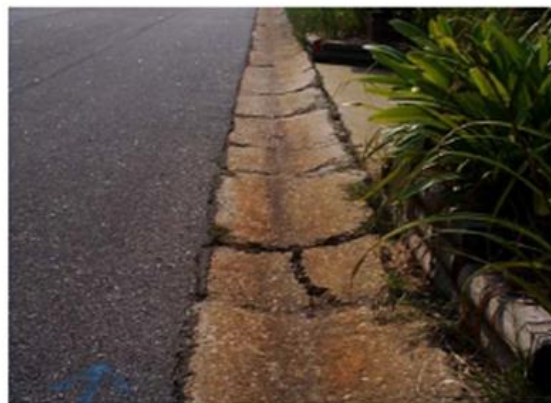

Example: Unsealed cracking greater than $\frac{3}{4}$ inches.

Pipes and Culverts

Desired Outcome: Structurally Sound, Open and Draining, and No Erosion or Sediment Effecting Functional Capacity

Definitions:

Cross Culverts (Pipes) – is a conduit channel that allows water to flow under a road, from one side of the road to the other. These normally run underneath the roadway, perpendicular to the direction of travel, and beginning or ending in an open roadside ditch.

Evaluation Standard:

1. Not more than 50% of the structure is obstructed or blocked.
2. Eroded area at the inlet or outlet is not wider or longer than 1.5 times the pipe diameter and greater than 6 inches deep.
3. End protection has no deteriorations, erosions, washouts or buildups adversely affecting the natural flow of water.
4. No metal pipes with crushed ends or rusted through.
5. No indications of asphalt or concrete roadway over drainage pipe is cracking, sinking, or rising.

Evaluation Procedure:

MQA inspection is limited to culverts less than 20 feet as measured longitudinally along the roadway. All culverts greater than 20 feet are inspected as part of the NBIS structure inspection program.

Determine the area of the culvert opening. Measure whether at least 50% of the opening is clear of obstruction. If more than 50% of either the inlet or outlet is blocked, the culvert does not meet the threshold condition. Consider the area within 1.5 times the pipe diameter of the outlet to the pipe to be assessed as pipe. Any blockage beyond 1.5 times the pipe diameter should be rated as outlet ditch blockage.

Observe whether there is any damage to pipes or end protection. There should be no crushed ends or exposed steel reinforcing. Check the road above the pipe for settlement, cracking, or rising that may indicate structural issues such as pipe joint separation or collapse.

Observe whether there is any significant flooding or erosion near the inlet or outlet. Erosion greater than 1.5 times the pipe diameter and greater than 6 inches deep does not meet the acceptable standard.

TDOT has an Aquatic Organism Passage (AOP) program for wet stream conveyance through culverts. To define, use the “72 hour” rule: “If water is present after 72 hours from the last rain event, inspector can assume waterbody is a stream. “

Culvert AOP requires stream beds to remain continuous through a culvert. This means the culvert pipe or box structure will be imbedded and the culvert bottom should have rocks and material similar to the stream bed. For MQA, start the blockage measurement from the top of the imbedded material in the bottom of the culvert.

AOP is not required on stormwater drainage (ditches). The culverts on drainage ditches will not be imbedded and any material within the culvert will be considered foreign debris.

Standard Diameter, D (inches)	Required unobstructed diameter, D_U (inches)
12	6.0
15	7.5
18	9
21	10.5
24	12
27	23.5
30	15
33	16.5
36	18

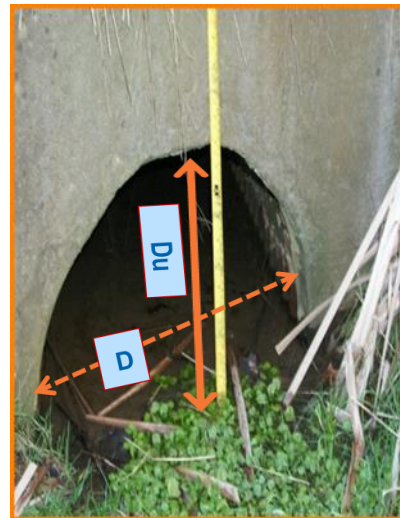



Example: Eroded area around inlet is greater than 1.5 times the diameter.



Example: Less than 50% of structure is blocked.



Example: Metal pipe is rusted through.

Miscellaneous Drainage Structures

Desired Outcomes: Functional and free of obstruction.

Definitions:

Miscellaneous Drainage Structure – This characteristic includes flumes, spillways, trench drains, edge drains, weep holes, piped slope drains and other miscellaneous drainage structures that are used to enhance or control the flow of runoff or storm drain water, but does not include curb and gutter, retention/detention ponds or siltation devices. Any grates encountered on miscellaneous drainage structures or manhole covers will be rated under the inlet characteristic. A piped slope drain that is connected to a side/cross drain is evaluated as side/cross drain. A piped slope drain that is connected to a side/cross drain is evaluated as side/cross drain.

Evaluation Standard:

1. Not more than 50% of the pipe or structure is obstructed or blocked.
2. End protection is free of deteriorations, erosions, washouts or buildups adversely affecting the natural flow of water.
3. Underdrain rodent screen (where applicable) is in place.

*Illicit Discharge - for TDEC reporting only. Note in comments and provide photo if observed. Does **NOT** constitute MQA failure.*

Evaluation Procedure:

To meet the required maintenance condition, each structure must function at no less than 50%. The miscellaneous drainage structure does not meet desired conditions when more than 50% of the structure is blocked or has deteriorations, erosions, washouts or buildups which adversely affect the natural flow of water. For underdrain outlets, evaluation is limited to the pipe outlet and the area of the structure pad for blockage.



Inlets

Desired Outcome: Free of Obstruction

Definitions:

Drainage Structures and Inlets – Drainage structures include curb inlets, drop inlets, junction boxes, grated inlets. They are specifically designed to collect surface runoff and deliver it to underground stormwater conveyance systems. This characteristic includes all inlets. Inlets may be found in curbs, ditches with or without ditch paving, in valley gutters, and at other locations that are designed to collect water runoff.

Evaluation Standard:

1. Grates and Outlets not blocked 50% or greater.
2. Grates are present, in place and not broken.
3. No eroded area within 1 foot of the structure that is greater than 6 inches deep or below the base elevation of the concrete apron.
4. Surface damage is not greater than 0.5 SF.
5. No cracking of the concrete apron greater than 0.25" over 10% of the apron area.
6. No unsealed concrete joint separations greater than 0.25".

Evaluation Procedure:

Measure the opening to determine the area. When any inlet structure is unslotted, the grate is the collection area to be measured. Grates must be the correct size and in place to meet maintenance conditions. Grates that are broken do not meet conditions. For a grate to be in place, it must be properly seated in the design cradle and cannot be unseated by normal pedestrian or vehicular traffic. Manhole lids are required to be fastened by an acceptable method. Inlets with exposed steel, surface damage ½ square foot or more, or any deformation of the inlet that creates a hazard are considered to fail the conditions. Gutter grates or gutter cover plates on slotted curb inlets are installed as cleaning or maintenance access and are not to be considered as part of the opening area.



Example: An inlet that has approximately less than 50% blocked would meet the threshold condition.



Example: Exposed steel in curb inlet and greater than 0.5 SF fails to meet the desired condition.



Example: An inlet fully obstructed.



Example: Cracking and misalignment of concrete apron.



Example: Grate is out of the cradle.



Example: More than 50% of the inlet is blocked.

ROADSIDE

Turf Condition and Mowing

Desired Outcome: Healthy growing, neat appearance

Definitions:

Turf – This includes grass and weed growth along right-of-way.

Evaluation Standard:

1. No more than 100 continuous SF of bare ground is present in the turf evaluation area, -or- more than 10% of the cumulative sample area is bare ground.
2. No more than 2% of the vegetation exceeds a uniform height of 18 inches. Minimum height not less than 4 inches.

Evaluation Procedure:

Calculate the mowing area in the sample section. Generally, the mowing standard along state roads includes the area adjacent to the roadway to 5 feet beyond the ditch line or 5 feet beyond the shoulder point down a fill slope. This is to include any 5-foot area behind guardrail. TDOT mowing patterns on interstate are generally as follows:

- 15 feet outside shoulders
- 15 feet inside median (if median is greater or equal to 60 feet in width), full width median (if less than 60 feet wide)
- Full width of entire interchange area
- Clean up cycle (full width of mowable right of way) at end of year

Determine the area of vegetation above the standard height of 18 inches by measuring with a rule or stick marked at the appropriate heights. Measure the average height of the grass from base to top as it stands, without pulling or standing the grass blades up.

If more than 2% of vegetation exceeds the appropriate measurement of 18 inches, then this characteristic does not meet the desired maintenance condition.



Example: Bare ground.

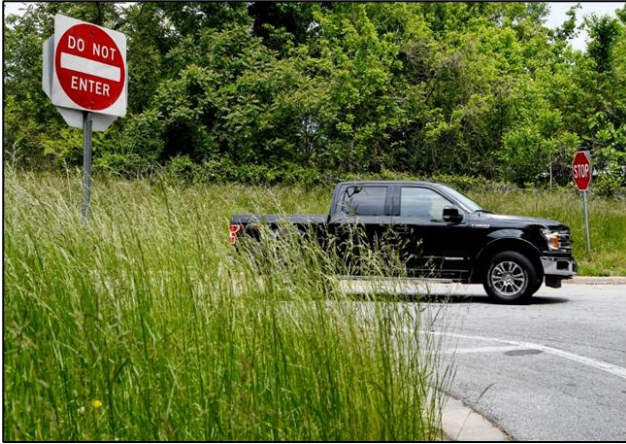

Example: Grass height would need to be measured. This may exceed 18". Picture should include tape measure.

Brush and Trees

Desired Outcome: Unobstructed Sight Distance & Vertical Clearance

Definitions:

Trees and Brush – This characteristic is the encroachment control of trees or tree limbs and heavy brush within the right-of-way.

Evaluation Standard:

1. No trees (leaning or dead) or woody growth are overhanging the pavement or shoulder on roadways obstructing sight distance or sign visibility (see Table below for distances).
2. Trees or woody growth 4 inches in diameter as measured 6" from the ground are not within 50 feet of travel way on mainline control access highway, measured along surface of ground.
 - a. All other SR routes – 5 feet back of ditch or 5 feet beyond the shoulder point on fill slopes.
 - b. Ramps – clear horizontal area to 10 feet back of ditch.
 - c. 15 feet clear distance behind guardrail and concrete barriers.
 - d. No woody vegetation around headwalls.
3. Vertical clearance over the roadway including any paved shoulder is not less than 16' - 6".
4. No dead trees or leaning live trees that present hazards to the travel lanes.

Noise Wall:

5. No more than 10% of exposed surface is covered with unwanted vegetation.
6. No woody vegetation / branches greater than 4 inches in diameter overhanging wall within 10 feet vertical.
7. No woody vegetation leaning against the wall greater than 4 inches in diameter.
- 8.

Evaluation Procedure:

Table 1 - Recommended Minimum Line of Sight, (L)		
Speed	Roadway Signs	Major Guide Signs
50 mph	450 ft	800 ft
55 mph	525 ft	800 ft
60 mph	600 ft	800 ft
65 mph	700 ft	800 ft
70 mph	800 ft	800 ft

SOURCE: FHWA & AASHTO

Confirm that trees and brush are not blocking any signs or pavement markings. Measure vertical clearance over roadway as necessary with a range pole. Use the 'Table 1' above from FHWA & AASHTO as guide for roadway signs on state routes other than controlled access / interstate. Take into account the limits of right of way and other reasonable physical restraints when determining failures.

Any dead trees or live trees leaning toward the travel lane of a height such that if the tree were

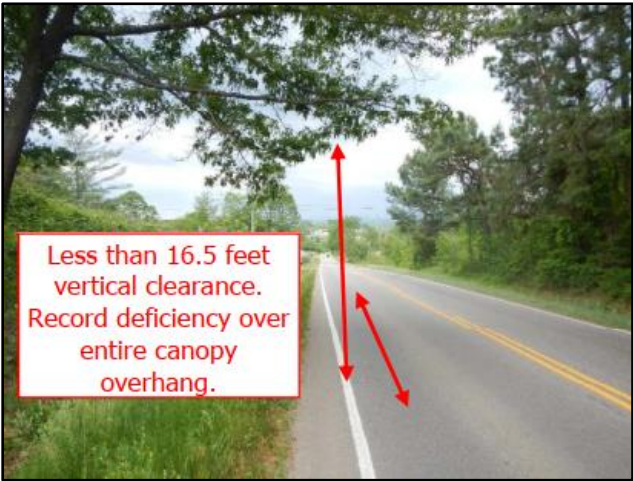

Example: Trees overhanging roadway and shoulder within 16.5 feet does not meet the desired condition.



Example: Sign obstruction.

to fall it would impact the travel lane or shoulder of the roadway represent a failure.

Roadway Sweeping

Desired Outcome: Free of any accumulation of sand or aggregate particles

Definitions:

Roadway Sweeping – Roadway sweeping includes the mechanical sweeping and removal of sand or aggregate particles and small items of debris from designated areas along the roadways. This activity applies to all travel lanes, curb and gutter, valley gutter, bridge deck/curb line, concrete barrier rail curb line, paved shoulders, and intersections. In areas with curb and gutter and sidewalk, sweeping includes areas around the returns to the back of the sidewalk.

Evaluation Standard:

1. No material accumulation exceeding 0.25 inches in depth for more than 10 continuous linear feet in the paved shoulder or paved lanes.
2. No material accumulation exceeding 0.75 inches in depth for more than 10 continuous linear feet in curb and gutter and concrete barrier.
3. No material accumulation exceeding 4 inches at any point in curb and gutter or along concrete barrier.

Evaluation Procedure:

Review all limited access roadways, and paved shoulders on limited access roadways, all curb and gutter, all valley gutter, all barrier wall, and all intersections with state roads to determine the debris buildup. Measure the depth and length of any buildup. If the debris buildup is more than allowed by the standard, it does not meet desired maintenance conditions. In areas with curb and gutter and no sidewalk, do not rate sweeping around the radius returns.



Example: Material accumulation in curb and gutter.

ROADSIDE APPURTENANCES

Guardrail / Cable Rail / Concrete Barrier

Desired Outcome: Functional Repairs per current Standards

Definitions:

Guardrail – This is installed to guide a vehicle away from various hazards in and adjacent to the travel way and, in most controlled access cases, where fill slopes exceed 3:1.

Functionally Damaged Guardrail is functionally damaged if a rail beam has been torn loose, if the beam is crushed more than 9” out of line or if two or more posts have been separated or one or more post is broken.

Functionally Damaged End Treatment – Functional damage of end treatment includes one or more broken posts, rail that has been torn loose from any post, any damage to the bulb, or a damaged cable assembly.

Functionally damaged concrete barrier includes any loss of cross-sectional height.

Moderate Damage - Traffic damage such as dents, surface scarring or tearing or misalignment, which will not affect guardrail function on a subsequent traffic hit.

Minor Damage – Slight dents, rust, or slight misalignment that is aesthetic and does not affect guardrail function.

Evaluation Standard:

1. No NON-FUNCTIONING GUARDRAIL damage.
2. No loss of concrete barrier cross-sectional area as a result of vehicle crash.

Evaluation Procedure:

Confirm that the entire length of guardrail in the sample section meets the performance standard requirements. There may not be guardrail for the whole length of the section, but any guardrail that exists should be evaluated within the boundary of the sample section. Determine the general condition of the guardrail. Check for damaged rail, missing or damaged posts or blocks, connecting hardware and end sections. Check to make sure guardrail is lapped correctly. Consideration should be given to what Design Standards were used during original construction of guardrail. A previous minor collision may not prevent a guardrail system from functioning as designed and would not cause failure. Installations may vary from roadway to roadway because of design standard changes and should be evaluated using the appropriate design standard.



Example: Guardrail with lateral deflection.



Example: Guardrail with damaged end section.



Example: Guardrail penetrated by a crash.



Example: Rotted offset block.

Impact Attenuators

Desired Outcome: Present, Operational

Definitions:

Attenuator – Vehicle impact attenuators are of various configurations and are designed for different roadway conditions. They are generally constructed of modules containing cells of different types of energy absorption materials. Attenuators are intended to provide a motor vehicle with a cushioned impact area prior to solid obstructions such as parapet walls, bridge columns, sign structures and signal poles.

Functional Damage – Traffic damage which prevents the restoration of the unit to "Like New" condition or which requires the full replacement of functional parts.

Evaluation Standard:

1. Functional damage; obvious malfunctions, such as water or sand containers that are split, compression of the device, misalignment, etc.

Evaluation Procedure:

Each impact attenuator in the sample section is to be evaluated. Determine the general condition of the attenuator. When damage to an attenuator system is discovered that may compromise its function, the responsible maintenance unit should be promptly notified. Inspect impact attenuators for debris accumulation, antifreeze protection for Hydro-cell Units, missing parts, etc. Impact attenuators damaged, missing parts, or in a condition where its function may be compromised does not meet desired maintenance conditions.



Example: Operational impact attenuator.



Example: Impact attenuator not operational.
Source: AZDOT

Control Access Fence

Desired Outcomes: Limit access, structurally sound and continuous.

Definitions:

Fence – Fences are constructed on limited access facilities and restricted areas to discourage people, animals and vehicles from entering the right-of-way at unauthorized locations.

Evaluation Standard:

1. No compression of the fence greater than 1/3 of its original height as measured from the natural ground to the top of the fence fabric.
2. No opening in the fence fabric greater than 2 square feet.
3. No open gate in the limited access fence within the sample area.

Evaluation Procedure:

Inspect the fence within the sample section. Any unauthorized opening in the fence line within the right-of-way that allows unrestrained access causes this characteristic not to meet the desired maintenance conditions. Unrestrained access is defined as less than 2/3 (67%) of its original height as measured from natural ground to the top of the fence fabric or any opening in the fence fabric greater than 2 square feet.

Rate fence across an outfall ditch as installed. Washouts under the fence are not rated in the fence component. Openings in fence for drainage structures will not fail fabric opening criteria.

If 100 feet or more of the fence can be reached / observed, then that portion of the fence should be evaluated. If after a reasonable effort, less than 100 feet of the fence can be inspected, do not rate the fence. Private fencing for landowners and businesses ARE NOT to be rated.



Example: Damaged fence.



Example: Tree fallen on fence.

Noise Walls and Retaining Walls

Desired Outcome: Structurally sound, clean.

Definitions:

Retaining Wall – A soil-retaining structure constructed of masonry block, cast-in-place concrete, brick, or a mechanically stabilized earth system.

Noise Wall – An exterior structure constructed of piles and precast concrete panels or brick designed to protect sensitive land uses from noise pollution and mitigate roadway noise sources.

Evaluation Standard:

1. No obvious wall damage; leaning/missing panel damage.

Evaluation Procedure:

Measure or estimate areas covered by unwanted vegetation and areas of all walls located within a sample section. Observe any vegetation within 10 feet of the top of the vertical wall or any leaning woody vegetation greater than 4 inches in diameter. Observe whether there is any obvious damage to the wall.

Graffiti

Desired Outcomes: Project is free of Graffiti

Definitions:

Graffiti – Graffiti is defined as inscriptions or drawings placed on fixtures, bridge structures, sound walls, barriers, retaining walls, sign and gantry structures, screen walls, pavement, etc.

Evaluation Standard:

1. No graffiti is present on the sample area on any surface within the right of way at the time of the evaluation.

Evaluation Procedure:

Inspect all structural surfaces within the sample section. Any graffiti observed within a sample section causes this characteristic not to meet the desired maintenance conditions.



Examples: Graffiti.

TRAFFIC

Ground Signs & Overhead Signs

Desired Outcome: 90% of the signs in the sample area are present, visible, legible.

Definitions:

Signs – Signs are used to convey information to the motorist so they can travel safely and efficiently on the highway. According to the “Manual on Uniform Traffic Control Devices”, placement of a traffic control device should be within the road user’s view so that maximum visual acuity is provided. To aid in conveying the proper meaning, the traffic control device should be appropriately positioned with respect to the location, object, or situation to which it applies. The location and legibility of the traffic control device should be such that a road user has adequate time to make the proper response in both day and night conditions.

Evaluation Standard: 90% of the signs in the sample area are present and functioning according to the below criteria. For the purposes of evaluating individual sign installations, the following MUTCD criteria shall apply:

Visibility, Height, Lateral Clearance, and Installation (see individual descriptions below)

1. Visibility
 - a. Warning lights on signs, where required, are functional.
 - b. Signs convey the intended message without fading or surface accumulations.
 - c. Surface has less than 10% of the area damaged affecting sign function. No partial or whole of a single word is missing.
 - d. No sign rotation causing the sign message to become unreadable.
 - e. For Interstate and NHS roads: Sign retroreflectivity must be at or above the minimum levels of retroreflectivity standards in Table 2A-3, per the 2009 MUTCD.
2. Height
 - a. Roads with curb and gutter: 7 feet minimum height measured from top of curb to bottom of sign (measure from sidewalk if present).
 - b. Roads without curb and gutter: 5 feet minimum height measured from edge of driving lane to bottom of sign’.
 - c. The distance between the bottom of chevron sign and edge of travel lane (or top of curb if present) is not a minimum of 4 feet.
 - d. The distance between the bottom of mainline mile marker and edge of travel lane (or top of curb if present) is not 4 feet.
3. Installation
 - a. Sign installation including panels and posts are leaning no more than 1 inch per foot.
 - b. No missing or improperly installed connecting hardware, nuts, or bolts.
 - c. Sign support is not damaged and/or bent.

- d. A slip base or breakaway support is not covered with soil or is no more than 4 inches above the finished ground as measured at the center
- e. U-channel steel posts heavier than 3 pounds per foot are not installed on a slip base or breakaway support.

Note: Signs shielded by barrier walls or guardrail do not require breakaway support

Evaluation Procedure: Evaluate only TDOT signs and devices. Determine the number of signs within the sample point. Inspect the signs and determine the number of signs that do not meet desired MQA conditions. Divide the number of signs that meet MQA conditions by the total number of signs in the sample point. Multiply by 100 to get the percentage of signs that function as intended. If the percent is less than the (90%) standard, then the signs in the sample area do not meet MQA threshold standard. Determine what Design Standards were used during original construction and installation of signs when evaluating for MQA. Signs shielded by barrier wall or guardrail do not require breakaway support.

NOTES:

1. The height to the bottom of a secondary sign mounted below another sign may be one foot less than the appropriate height except where signs are over sidewalks (a route marking assembly consisting of a route marker with an auxiliary plate is treated as a single sign).
2. For purposes of these guidelines, a turn lane will be considered a driving lane.
3. If it is obvious the minimum lateral clearance cannot be met by physical restraints of the right of way, the sign shall be considered to meet acceptable maintenance conditions. The presence of sidewalk by itself shall not be considered a reason a sign cannot meet the minimum lateral clearance.
4. Signs in a divided median, are not evaluated for lateral clearance.
5. The evaluation of overhead signs does not include evaluation of the overhead structure.
6. Signs on signal mast arms are not included in this sign evaluation.
7. The dynamic message system is not included in this sign evaluation.
8. Logo signs are managed by others and are not evaluated in the MQA.

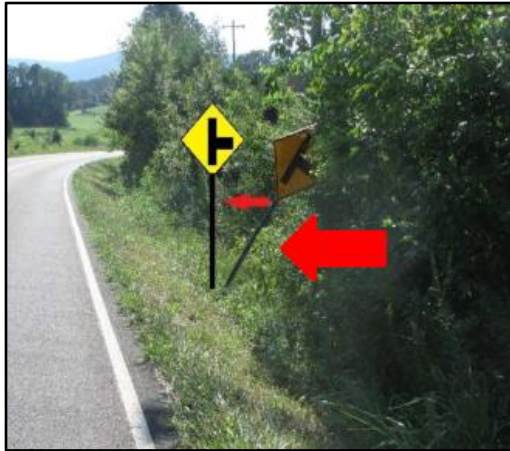

Example: Sign leaning more than 1 inch per foot.



Example: Measuring sign leaning. 4 inches at the top of a 4-foot level = 1 inch per foot.



Example: This u-channel post is lapped onto the previous sign mount which creates a greater than 3 lbs/ft weight without a breakaway assemble and does not meet the desired condition.



Example: Faded sign with sign face missing damage.

Miscellaneous sign information

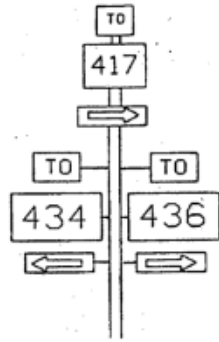

This sign assembly has three (3) messages and therefore should be rated as three (3) signs.

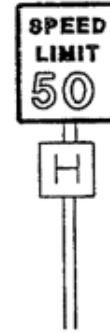

This is a regulatory sign with a hospital sign below it. The hospital sign is considered a secondary sign because its message is not related to the regulatory sign message.

FIGURE 23: SIGN CLEAR HEIGHT STANDARDS

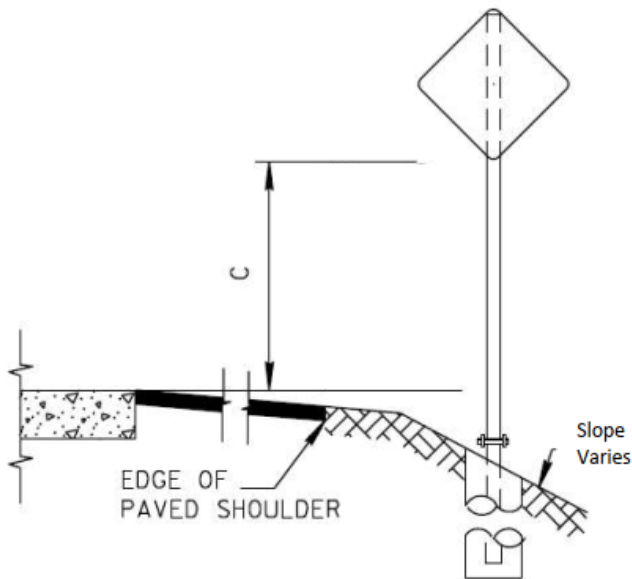

CLEAR HEIGHT OF SIGN (C)

RURAL (8)	5'
URBAN	7'
FREEWAY	7'

Pavement Markings

Desired Outcome: Visible

Definitions:

Striping – Pavement striping includes all 4- or 6-inch-wide centerline, skip line, or edge line.

Evaluation Standard:

1. No more than 10% of the length of any line is missing, covered by soil, grass or debris.

Evaluation Procedure:

Only daylight assessments are required. Each solid line and each continuous run of skip line is evaluated independently. Should any independent line not meet the 90% standard, the MQA standard is not met.

Solid lines – Determine the length and width of each solid line in the sample. A minimum of 5.4 or 3.6 inches of each line width should be present and visible.

Skip lines – Determine the length and width of each continuous directional run of skip lines in the sample. A minimum of 5.4 or 3.6 inches of each line width should be present and visible. On concrete pavement, black lines are used for contrast only and should not be evaluated.



Example: More than 10% of striping has worn off.



Example: Striping faded.

Words and Symbols

Desired Outcome: Visible

Definitions:

Words and Symbols – Pavement symbols, including words, are used to communicate certain traffic meanings at specific locations. Included in this characteristic are gore area markings, shoulder markings, word and symbol markings, stop bars, all crosswalk lines within the right-of-way, parking space markings (not including edge lines that delineate parking), curb markings, painted medians, radius markings and others.

Evaluation Standard:

1. No more than 30% of the symbol area is worn, missing or not visible.

Evaluation Procedure:

Only daylight assessments are required. Determine the total square footage of all symbols within the sample point. Symbols that appear to be abandoned should be verified as such with the traffic engineer and not evaluated if determined to be abandoned.

Pavement words and symbols do NOT meet MQA standards when the following is true:

- If more than 30% of the cumulative symbol area is not functioning as intended during daylight observation.



Examples: 30% of area of symbol is missing. Symbol depicted on left is intended to be a straight arrow. Symbol depicted on right is intended to denote an approaching railroad crossing.

Object Markers and Delineators

Desired Outcomes: Present, Functional

Definitions:

Object Markers – Object markers are used to mark obstructions within or adjacent to the roadway.

Delineators – Delineators are particularly beneficial at locations where the alignment might be confusing or unexpected, such as at lane reduction transitions and curves.

Delineators are effective guidance devices at night and during adverse weather. An important advantage of delineators in certain locations is that they remain visible when the roadway is wet or snow covered. Reflective elements for delineators shall have a minimum dimension of 3 inches. Post mounted delineators are not required where snow-plowable pavement markers are present. This characteristic also includes the clear or amber “button” type reflectors installed on guardrail and barrier wall systems, button or combination button and reflective sheeting markers used at crossovers and other applications where object or guide marking is used.



Reflective road markers and delineator posts dramatically improve highway safety.

Evaluation Standard:

1. No more than 30% of the object markers or post-mounted delineators lean more than 45 degrees.
2. No more than 30% of the required markers and delineators are missing or no more than 2 continuous markers are absent.

Evaluation Procedure:

Evaluation criteria is only applicable to ramps. Do not assess delineators on mainline.

For evaluation purposes, this characteristic will include clear or amber “button” type reflectors, button or combination button and reflective sheeting markers used at crossovers and other applications where object or guide marking is used.

Rate all post-mounted markers except those installed to prohibit unauthorized traffic movements (off-tracking, median crossing, shoulder parking, etc.). Rate post-mounted delineators at major/minor intersections, if installed. Day observations should have at least 70% of the required markers present.

Post-mounted delineators at median crossovers and major and minor roads shall be rated according to the design standard.

Glare Screens

Desired Outcome: Present, Functional

Definition: Glare Screens are commonly mounted on the top of median barrier walls to provide a 'glare screen' between opposing lanes of traffic. Glare screens are manufactured from a variety of materials (mesh fabric, plastic or metal foils, etc.) and have several mounting techniques.

Evaluation Standard:

1. No more than 10% missing or damaged portions of screens

Evaluation Procedure: Determine the total length of glare screens in the sample area. The total damaged or missing portion should not exceed 10% of the total length. Since the screens are mounted in the median, you may estimate the lengths by counting pavement marking skip lines which are 40 feet apart. Any portion of the height that is missing or damaged should be counted in the total length that fails.

THRESHOLD CRITERIA TABLES

TABLE 1			
PAVEMENT (0.2)			
Element Target: 75%			
CHARACTERISTIC	OUTCOME	PERF. TARGET (%)	TOLERANCE & CRITERIA
Flexible Pavement Travel Lane Repair (0.45)	Safe, durable, smooth	70	<ul style="list-style-type: none"> • No potholes greater than 6 inches in diameter and 1.25 inch or greater in depth. • No permeable base exposed. • No more than 50 cumulative feet of unsealed longitudinal joints larger than 0.25 inches.
Rigid Pavement Travel Lane Repair (0.45)	Safe, durable, smooth	70	<ul style="list-style-type: none"> • No potholes greater than 6 inches in diameter and 1.25 inch or greater in depth. • No more than 25% of the joint material is missing or detached. • No more than 10% of the surface area with spalling greater than 1 inch deep. • No vertical deviation (settlement or heaving) greater than 1 inch in depth.
Paved Shoulders (Flexible or Rigid) (0.10)	Safe, smooth	70	<ul style="list-style-type: none"> • No potholes greater than 6 inches in diameter and 1.25 inch or greater in depth. • No more than 50 continuous linear feet of the rumble strips are missing, filled with debris, or damaged in a manner rendering them ineffective. • No travel-lane edge differentiation greater than 2" for 25 continuous feet or greater than 4" at any location. • No more than 25% of the joint material is missing or detached. (Between lane and shoulder) • No settlements or heaving greater than 2 inches.

TABLE 2
UNPAVED SHOULDERS AND DITCHES (0.10)
Element Targets: 75%

CHARACTERISTIC	OUTCOME	PERF. TARGET (%)	TOLERANCE & CRITERIA
Unpaved Shoulders (0.50)	Safe Smooth	70	<ul style="list-style-type: none"> • No drop-offs greater than 2” within one foot (1’) of the edge of pavement for 25 continuous feet or 100 cumulative feet, or 4 inches anywhere along the shoulder template. • No shoulder build-up exceeds 2 inches across the design template for 25 continuous feet
Front / Back Slopes (0.10)	Stable with minimal erosion.	70	<ul style="list-style-type: none"> • No erosion greater than 6 inches in depth.
Lateral and Outfall Ditches (Unpaved Ditch) (0.30)	No blockage or erosion.	70	<ul style="list-style-type: none"> • No more than 50 cumulative linear feet of ditch with >50% of cross sectional blocked , or any single blockage of 100%. • No erosion greater than 1’ below original ditch line.
Paved Ditch (0.10)	Structurally sound, open and draining	70	<ul style="list-style-type: none"> • No more than 50 cumulative linear feet of ditch with >50% of cross sectional blocked , or any single blockage of 100%. • No undermining or erosion is present at either end or along the parallel edges that exposes any soil area beneath the paved ditch and threatens the structural integrity. • No settlement or misalignment greater than 2 inches. • No more than 10% of the surface area has cracking exceeding 0.5 inches in width.

TABLE 3
DRAINAGE Structures (0.15)
Element Targets: 75%

CHARACTERISTIC	OUTCOME	PERF. TARGET (%)	TOLERANCE & CRITERIA
Curb & Gutter (settlement / Damaged) (0.20)	No settlement, damage	70	<ul style="list-style-type: none"> • No Settlement greater than 2 inches • No Misalignment greater than 2 inches • No Structural damage is present. <p>Note: Any unsealed cracking that is 0.75 inches or greater on 10% of the cumulative length will be considered damaged.</p>
Pipes and Culverts (< 20 ft.) (Blocked / Damaged) (0.40)	Open Drains No Erosion	70	<ul style="list-style-type: none"> • Not more than 25% of the structure is obstructed or blocked. • Eroded area at the inlet or outlet is not wider or longer than 1.5 times the pipe diameter and greater than 6 inches deep. • End protection has no deteriorations, erosions, washouts or buildups adversely affecting the natural flow of water. • No metal pipes with crushed ends or rusted through. • No indications of asphalt or concrete roadway over drainage pipe is cracking, sinking, or rising.
Misc. Drainage Structures includes flumes, spillways, trench drains, edge drains, weep holes, piped slope drains and other misc. drain structures (Block/Damaged) (0.10)	Functional and free of obstructions	70	<ul style="list-style-type: none"> • Not more than 25% of the pipe or structure is obstructed or blocked. • End protection is free of deteriorations, erosions, washouts or buildups adversely affecting the natural flow of water. • Underdrain rodent screen is in place.

<p style="text-align: center;">Inlets (0.30)</p>	<p style="text-align: center;">Free of obstruction</p>	<p style="text-align: center;">70</p>	<ul style="list-style-type: none"> • Grates and Outlets not blocked 25% or greater. • Grates are present, in place and not broken • No eroded area within 1 foot of the structure that is greater than 6 inches deep or below the base elevation of the concrete apron. • Surface damage is not greater than 0.5 SF. • No cracking of the concrete apron greater than 0.25" over 10% of the apron area. • No unsealed concrete joint separations greater than 0.25".
--	--	---------------------------------------	--

TABLE 4
ROADSIDE (0.10)
Element Targets: 75%

CHARACTERISTIC	OUTCOME	PERF. TARGET (%)	TOLERANCE & CRITERIA
Turf Condition/ Seeding & Mulching (0.20) SR (0.60) PBMC	Healthy growing Neat appearance	70	<ul style="list-style-type: none"> No more than 100 continuous SF of bare ground is present in the turf evaluation area, - or- more than 10% of the cumulative sample area is bare ground.
Mowing (0.20) SR (0.00) PBMC	Grass height & mowing quality	N/A	Prescribed Maintenance Standard (PBMC) <ul style="list-style-type: none"> No more than 2% of the vegetation exceeds a uniform height of 18 inches. Minimum height not less than 4 inches.
Brush & Trees (0.30) SR (0.30) PBMC	Unobstructed sight distance & vertical clearance.	70	<ul style="list-style-type: none"> No trees (leaning or dead) or woody growth are overhanging the pavement or shoulder on roadways. No obstructions of sight distance or sign visibility (see manual for distances). Trees or woody growth do not meet the lateral clearance criteria. (see manual for distances) No woody vegetation around headwalls Vertical clearance over the roadway including any paved shoulder is not less than 16'- 6". No dead trees or leaning trees that present hazards to the travel lanes.
Roadway Sweeping (0.30) SR (0.00) PBMC	Free of any accumulation of sand or aggregate particles	70	<ul style="list-style-type: none"> No material accumulation exceeding 0.25 inches in depth for more than 10 continuous linear feet in the paved shoulder or paved lanes. No material accumulation exceeding 0.75 inches in depth for more than 10 continuous linear feet in curb and gutter and concrete barrier. No material accumulation exceeding 4 inches at any point in curb and gutter or along concrete barrier.
Retaining Walls / MSE Walls (0.10)	Safe Clean Functional Stable	70	<ul style="list-style-type: none"> Concrete elements have no spalls ≥ 2 inches deep. Weep holes are clean and free of foreign

			<p>material and properly functioning.</p> <ul style="list-style-type: none"> • Less than 10% of the surface is covered by live vegetation. • No branches greater than 2 inches in diameter overhanging wall.
Litter (0.0)	Neat Attractive	N/A	Prescribed Maintenance Standard

TABLE 5
ROADSIDE APPURTENANCES (0.15)

Element Target: 75%

CHARACTERISTIC	OUTCOME	PERF. TARGET (%)	TOLERANCE & CRITERIA
Guardrail/ Cable Rail / Concrete Barrier (0.40)	Functional Repairs per current Standards	70	<ul style="list-style-type: none"> No HIGH or MEDIUM PRIORITY damage guardrail: damaged end sections, or rail has penetrations or tears, loss of any tension in cable rail or cross-sectional loss of concrete barrier. SEE TIMELINESS REQUIREMENTS No loss of concrete barrier cross-sectional area as a result of vehicle crash.
Impact Attenuators (0.30)	Present Operational	70	<ul style="list-style-type: none"> No Functional damage; obvious malfunctions, such as water or sand containers that are split, compression of the device, misalignment, no missing parts. SEE TIMELINESS REQUIREMENTS
Control Access Fence (0.10)	Limit access, structurally sound and continuous	70	<ul style="list-style-type: none"> No compression of the fence greater than 1/3 of its original height as measured from the natural ground to the top of the fence fabric. No opening in the fence fabric greater than 2 square feet. No open gate in the limited access fence within the sample area.
Noise Walls and Retaining Walls (0.10)	Structurally Sound, Clean	70	<ul style="list-style-type: none"> No obvious wall damage; leaning/missing panel damage. No more than 10% of exposed surface is covered with unwanted vegetation. No branches greater than 4 inches in diameter overhanging wall within 10 feet vertical. No vegetation leaning against the wall greater than 4 inches in diameter.
Graffiti (0.10)	Project is free of Graffiti	100	<ul style="list-style-type: none"> No graffiti is present on the sample area on any surface within the right of way at the time of the evaluation.

TABLE 6
TRAFFIC (0.30)
Element Targets: 75%

CHARACTERISTIC	OUTCOME	PERF. TARGET (%)	TOLERANCE & CRITERIA
<p style="text-align: center;">Ground Signs & Overhead Signs (0.35) SR (0.50) PBMC</p>	<p style="text-align: center;">90% of the Signs in the sample area are present, visible, legible.</p>	<p style="text-align: center;">70</p>	<p>Visibility</p> <ul style="list-style-type: none"> • Warning lights on signs, where required, are functional. • Signs convey the intended message without fading or surface accumulations. • Surface has less than 10% of the area damaged affecting sign function. No partial or whole of a single word missing. • No sign rotation causing the sign message to become unreadable. • For Interstate and NHS roads: Sign retroreflectivity must be at or above the minimum levels of retroreflectivity standards in Table 2A-3, per the 2009 MUTCD. <p>Height</p> <ul style="list-style-type: none"> • Roads with curb and gutter: 7 feet minimum height measured from top of curb to bottom of sign (measure from sidewalk if present). • Roads without curb and gutter: 5 feet minimum height measured from edge of driving lane to bottom of sign. <p>Installation</p> <ul style="list-style-type: none"> • Sign installation including panels and posts are leaning no more than 1 inch per foot. • No missing or improperly installed connecting hardware, nuts, or bolts. • Sign support is not damaged and/or bent. • A slip base or breakaway support is not covered with soil or is no more than 4 inches above the finished ground as measured at the center. • U-channel steel posts heavier than 3 pounds per foot are not installed on a slip base or breakaway support. <p>Note: Signs shielded by barrier walls or guardrail do not require breakaway support.</p>

Pavement Markings (0.35) SR (0.0) PBMC	Visible	70	<ul style="list-style-type: none"> No more than 10% of the length of any line is missing, covered by soil, grass or debris.
Words and Symbols (0.15) SR (0.30) PBMC	Visible	70	<ul style="list-style-type: none"> No more than 30% of the symbol area is worn, missing or not visible.
Object Markers & Delineators (0.1 5)	Present Functional	70	<ul style="list-style-type: none"> No more than 30% of the object markers or post-mounted delineators lean more than 45 degrees. No more than 30% of the required markers and delineators are missing or no more than 2 continuous markers are absent.
Glare Screens (0.05)	Present Functional	70	<ul style="list-style-type: none"> No more than 10% missing or damaged portions of screens.

APPENDIX A

Summary of W-beam barrier repair thresholds

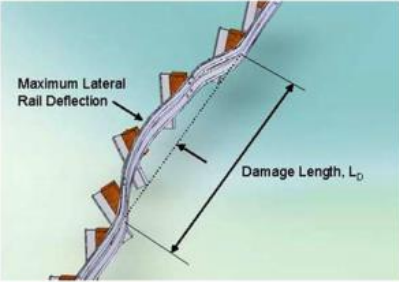
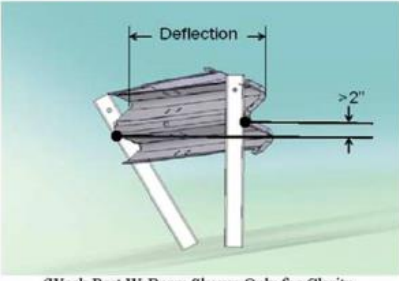
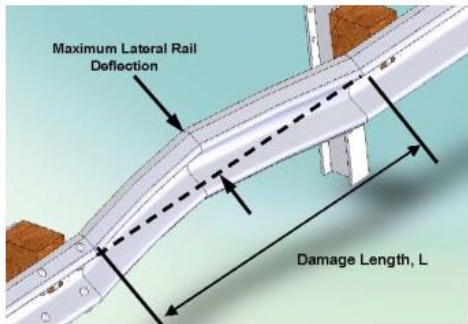
Damage Mode	Repair Threshold	Relative Priority	Measurement
Post and Rail Deflection	One or more of the following thresholds: <ul style="list-style-type: none"> More than 9 inches of lateral deflection anywhere over a 25 ft length of rail. Top of rail height 2 or more inches lower than original top of rail height. 	High	  <p style="font-size: small;">(Weak Post W-Beam Shown Only for Clarity. Each measurement taken at rail middle fold)</p>
	6-9 inches lateral deflection anywhere over a 25 ft length of rail.	Medium	
	Less than 6 inches of lateral deflection over 25 ft length of rail.	Low	
Rail Deflection Only	6-9 inches of lateral deflection between any two adjacent posts. Note: For deflection over 9 inches, use post/rail deflection guidelines.	Medium	
	Less than 6 inches of lateral deflection between any two adjacent posts.	Low	

(continued on next page)

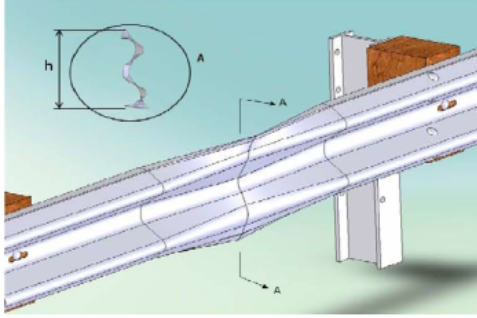
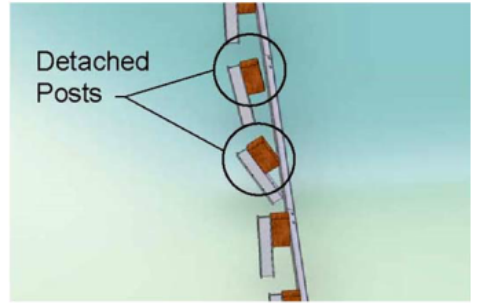
Damage Mode	Repair Threshold	Relative Priority	Measurement
Rail Flattening	One of more of the following thresholds: <ul style="list-style-type: none"> • Rail cross-section height, h, more than 17" (such as may occur if rail is flattened). • Rail cross-section height, h, less than 9" (such as a dent to top edge). 	Medium	
	Rail cross-section height, h, between 9 and 17 inches.	Low	
Posts Separated from Rail	<ul style="list-style-type: none"> • 2 or more posts with block-out attached with post-rail separation less than 3 inches. • 1 or more post with post-rail separation which exceeds 3 inches. 	Medium	
	<ul style="list-style-type: none"> • 1 post with block-out attached with post-rail separation less than 3 inches. 	Low	Note: <ol style="list-style-type: none"> 1. If the block-out is not firmly attached to the post, use the missing block-out guidelines. 2. Damage should also be evaluated against post/rail deflection guidelines.

(continued on next page)

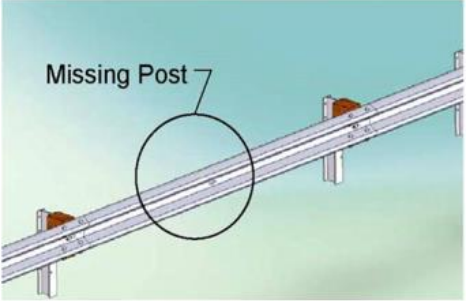
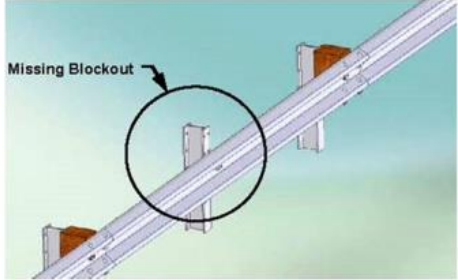
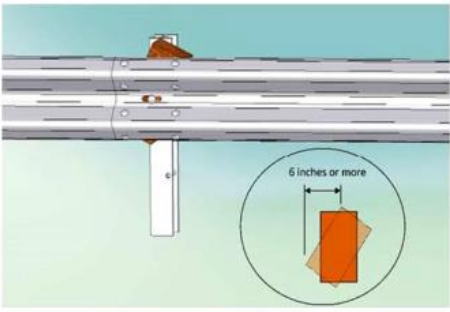
Damage Mode	Repair Threshold	Relative Priority	Measurement
Missing/Broken Posts	1 or more posts <ul style="list-style-type: none"> • Missing • Cracked across the grain • Broken • Rotten • With metal tears 	High	
Missing Block-out	Any block-outs <ul style="list-style-type: none"> • Missing • Cracked across the grain • Cracked from top or bottom block-out through post bolt hole • Rotted 	Medium	
Twisted Block-outs	Any misaligned block-outs, top edge of block 6 inches or more from bottom edge. Note: Repairs of twisted block-out are relatively quick and inexpensive	Low	

(continued on next page)

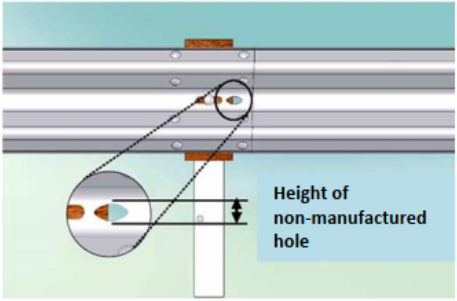
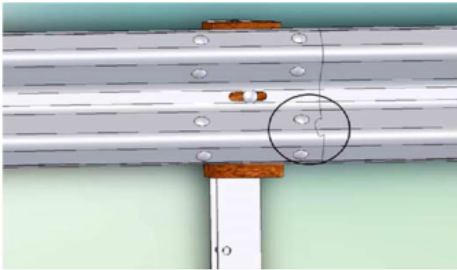
Damage Mode	Repair Threshold	Relative Priority	Measurement
<p>Non-Manufactured holes (such as crash induced holes, lug-nut damage, or holes rusted-through the rail)</p>	<ul style="list-style-type: none"> • More than 2 holes less than 1" in height in a 12.5' length of rail. • Any holes greater than 1" height. • Any hole which intersects either the top or bottom edge of the rail. 	High	
	<p>1-2 holes less than 1" in height in a 12.5' length of rail.</p>	Medium	
<p>Damage at a rail splice</p>	<p>More than 1 splice bolt:</p> <ul style="list-style-type: none"> • Missing • Damaged • Visibly missing any underlying rail • Torn through rail 	High	
	<p>1 splice bolt:</p> <ul style="list-style-type: none"> • Missing • Damaged • Visibly missing any underlying rail • Torn through rail 	Medium	

(continued on next page)

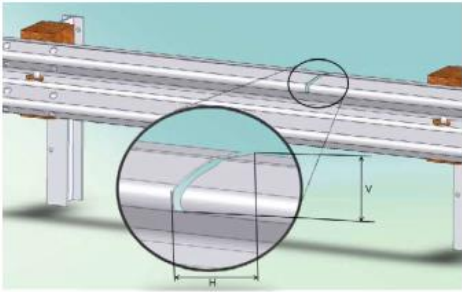
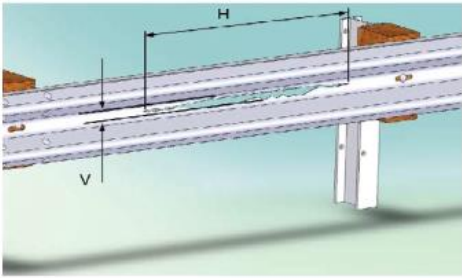
Damage Mode	Repair Threshold	Relative Priority	Measurement
Vertical Tear	Any length vertical (transverse) tear	High	
Horizontal Tear	<p>Horizontal (longitudinal) tears greater than 12 inches long or greater than 0.5 inches wide.</p> <p>Note: for horizontal tears less than 12 inches in length or less than 0.5 inches in height, use the non-manufactured holes guidelines.</p>	Medium	

Summary of generic end terminal repair thresholds

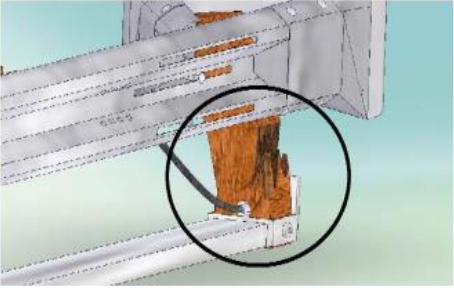
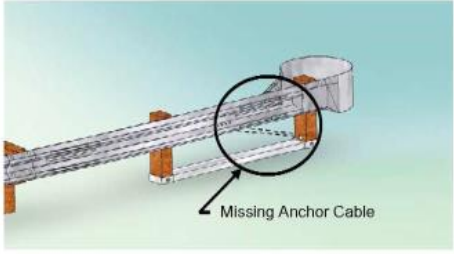
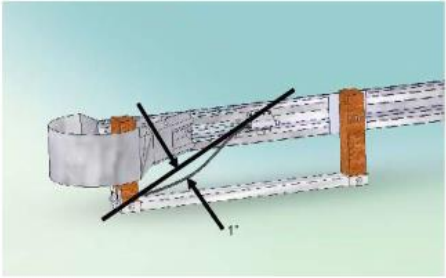
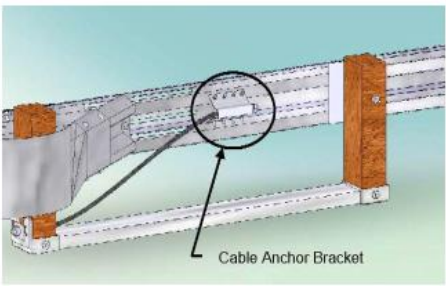
Damage Mode	Repair Threshold	Relative Priority	Measurement
Damage End Post	Not functional (sheared, rotted, cracked across the grain)	High	 A 3D model of a structural end post. A circular callout highlights a section of the post that is severely damaged, appearing rotted and cracked across its grain.
Anchor Cable	Missing	High	 A 3D model of a structural member with an anchor cable. A circular callout highlights the location where the anchor cable is missing. An arrow points to the gap with the label "Missing Anchor Cable".
Anchor Cable	More than 1" of movement when pushed down by hand	Medium	 A 3D model of a structural member with an anchor cable. Two black arrows indicate the direction of movement. A vertical dimension line between the arrows is labeled "1\"", indicating the threshold for movement.
Cable Anchor Bracket	Loose or not firmly seated in rail	Medium	 A 3D model of a structural member with a cable anchor bracket. A circular callout highlights the bracket's connection to the rail. An arrow points to the bracket with the label "Cable Anchor Bracket".

(continued on next page)

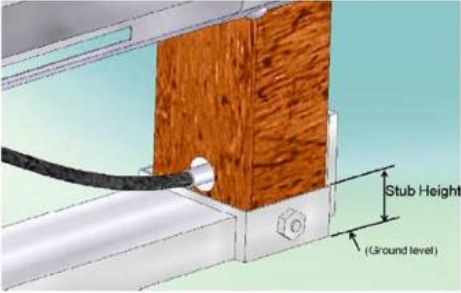
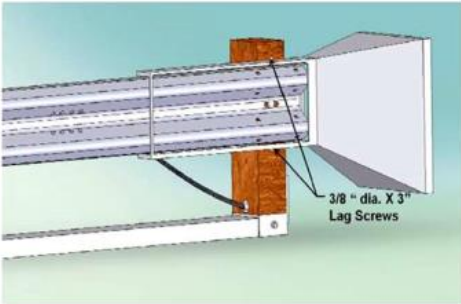
Damage Mode	Repair Threshold	Relative Priority	Measurement
Stub Height	Height which exceeds 4"	Medium	
Lag Screws (Energy Absorbing Terminals Only)	Missing or failed lag Screws	High	

(continued on next page)

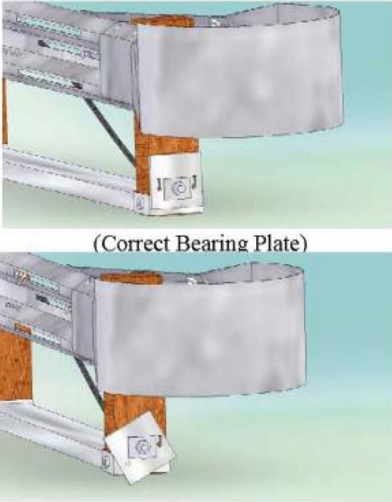
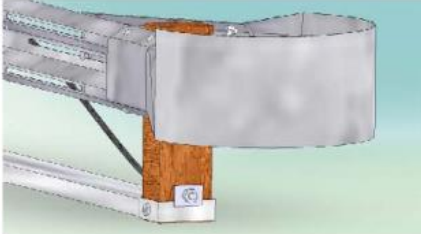
Damage Mode	Repair Threshold	Relative Priority	Measurement
Bearing Plate	Loose or Misaligned	Medium	 <p data-bbox="1024 663 1243 688">(Correct Bearing Plate)</p> <p data-bbox="1008 951 1260 976">(Misaligned Bearing Plate)</p>
	Missing Bearing Plate	High	 <p data-bbox="1029 1276 1255 1302">(Missing Bearing Plate)</p>