

RULES OF
TENNESSEE DEPARTMENT OF TRANSPORTATION
MAINTENANCE RIGHT OF WAY DIVISION

CHAPTER 1680-026-03
CONTROL OF OUTDOOR ADVERTISING

TABLE OF CONTENTS

1680-026-03-.01	_____ Preface	1680-026-03-.06	_____ On-premises signs <u>devices</u>
1680-026-03-.02	_____ Definitions	1680-026-03-.07	_____ Removal of abandoned <u>devices</u>
1680-026-03-.03	_____ Criteria for the erection and control of outdoor advertising <u>devices</u>	1680-026-03-.08	_____ Vegetation control
1680-026-03-.04	_____ <u>Permits, renewals, and administrative hearings</u>	1680-026-03-.09	_____ Appendix
1680-026-03-.05	_____ <u>Directional signs</u> Control of nonconforming outdoor advertising <u>devices</u>	1680-02-03-.10	through
		1680-02-03-.13	Repealed

1680-026-03-.01 PREFACE.

~~The purpose of these regulations have been established by the Tennessee Department of Transportation, Maintenance Division, is to implement and enforce the Outdoor Advertising Control Act of 2020 (effective June 22, 2020) to provide for effective control of Outdoor Advertising devices within the adjacent area of highways on Federal Aid the interstate and Primary and Federal Aid Interstate highway systems within the State of Tennessee in accordance with and as required by 23 U.S.C. § 131 and 23 CFR Part 750, subject only to any limitations imposed by the United States Constitution as determined in the final judgment of a tribunal having jurisdiction over the matter. The Outdoor Advertising Control Act of 2020 and these regulations are subject to any applicable requirements of the Tennessee Constitution.~~

Authority: T.C.A. § 54-21-~~23~~111 and 23 U.S.C §131. Administrative History: Original rule certified June 10, 1974. Repeal and new rule filed June 9, 1977; effective July 11, 1977. Repeal and new rule filed January 27, 1989; effective March 13, 1989.

1680-026-03-.02 DEFINITIONS. ~~(Listed Alphabetically)~~

- (1) ~~“Abandoned Outdoor Advertising Device,”~~ means any regulated outdoor advertising device ~~which that~~ for a twelve-month period falls into one or more of the following classifications:
- (a) ~~a~~ A device in substantial need of repair, ~~which means that, in the case of wooden sign structures, sixty percent (60%) or more of the upright poles or supports of a sign structure are physically damaged such that normal repair practices would call for replacement of the broken supports or, in the case of metal sign structures, replacement of at least thirty percent (30%) of the length above ground of each broken, bent, or twisted support; provided, however, that a nonconforming device in a condition meeting these criteria will immediately be considered destroyed rather than abandoned;~~
 - (b) ~~a~~ A device whose sign face ~~or faces is~~ remains damaged fifty percent (50%) or more, ~~or in the case of a device with multiple sign faces, each sign face that remains damaged fifty percent (50%) or more;~~
 - (c) ~~a~~ A device ~~which displays only a message of its availability for advertising purposes, with a blank sign face (i.e., no advertising message), or in the case of a device with multiple sign faces, each sign face that remains blank; or~~
 - (d) ~~A~~ A device that has been removed and has not been reconstructed in its permitted location; ~~provided, however, that a nonconforming device that has been removed will immediately be considered destroyed rather than abandoned.~~

(Rule 1680-026-03-.02,

(e) The twelve-month period for establishing abandonment under subparagraphs (a) – (d) may be waived or suspended during a period of involuntary discontinuance, such as the closing of a highway for repair in front of the sign; provided, however, that the termination of the permit holder's lease, easement, or other right or permission for access from the landowner shall not be grounds for waiver of the twelve-month period for establishing abandonment.

(See illustrations in Rule 1680-06-03-.09, Appendix.)

(2) "Adjacent Area," means that area within six hundred sixty feet (660') of the nearest edge of the right-of-way of interstate and primary highways and visible from the main traveled way of the interstate or primary highways. (See Rule 1680-06-03-.03(1) for additional explanation regarding standards for measurement of the adjacent area.)

(3) "Agreement," means the agreement entered into, pursuant to T.C.A. § 54-21-~~446~~113, between the ~~Commissioner~~Department and the ~~Secretary~~United States Department of Transportation, of the ~~United States~~Federal Highway Administration, regarding the definition of unzoned commercial and industrial areas, and size, lighting, and spacing of certain outdoor advertising devices. (Copies of the original agreement, dated November 11, 1971, and the supplemental agreement, dated October 16, 1984, are included in Rule 1680-06-03-.09, Appendix.)

(4) "Changeable message sign" means an outdoor advertising device that displays a series of messages at intervals by means of digital display or mechanical rotating panels.

(5) "Commissioner," means the Commissioner of the Tennessee Department of Transportation or the Commissioner's designee.

(6) "Compensation" means the exchange of anything of value, including money, securities, real property interests, personal property interests, goods or services, promise of future payment, or forbearance of debt.

(7) "Comprehensive Zoning," means a complete approach to land use within an entire political subdivision. For example, the mere placing of the label "Zoned Commercial or Industrial" on ~~lands~~ land use classification for taxation purposes does not constitute comprehensive zoning, but rather, Comprehensive zoning requires the establishment of a complete set of regulations to govern the land use within the entire political subdivision ~~is required~~.

(8) "Conforming" means an outdoor advertising device that was permitted under and conforms to the zoning, size, lighting, and spacing criteria established in accordance with either the current supplemental agreement entered into between the Department and Federal Highway Administration on October 16, 1984, or the original agreement entered into on November 11, 1971, as authorized in § 54-21-113. Any permitted outdoor advertising device that continues to conform to either the current supplemental agreement or the original agreement and conditions provided in § 54-21-113 is considered conforming.

(9) "Controlled access highway" means a divided highway with full control of access, including grade-separated interchanges rather than at-grade intersections, and with no permitted driveway entrances or exits from the main traveled way.

(10) "Customary maintenance" means maintenance of a nonconforming outdoor advertising device, which may include, but shall not exceed, the replacement of the sign face and stringers in like materials, and the replacement in like materials of up to fifty percent (50%) of the device's poles, posts, or other support structures; provided, that the replacement of any poles, posts, or other support structures is limited to one (1) time within a twenty-four-month period. (See illustrations

(Rule 1680-026-03-.02,
in Rule 1680-06-03-.09, Appendix.)

- (11) “Department;” means the Tennessee Department of Transportation.
- (12) “Destroyed;” means, with respect to a non-conforming and grandfathered non-conforming outdoor advertising devices, means that, in the case of wooden sign structures, fifty-sixty percent (50/60%) or more of the device’s upright poles or posts supports of a sign structure are dislocated or physically damaged to the extent such that normal repair practices would call for replacement of the broken supports or, in the case of metal sign structures, replacement of at least thirty percent (30%) of the length above any part of the stringers or sign face has fallen to the ground of each broken, bent, or twisted support. (See illustrations in Rule 1680-06-03-.09, Appendix.)
- (13) “Digital display” means a type of changeable message sign that displays a series of messages at intervals through the electronic coding of lights or light emitting diodes or any other means that does not use or require mechanical rotating panels.
- (14) “Directional Ssign;” means containing directional information about public places owned or operated by Federal, State, or local government or their agencies; publicly or privately owned natural phenomena, historic, cultural, scientific, educational, religious sites, and areas of natural scenic beauty or naturally suited for outdoor recreation a type of official sign that identifies a site, attraction, or activity and directional information useful to a traveler in locating the site, attraction, or activity, including mileage, route numbers, or exit numbers.
- (15) Double-faced, Bback-to-Bback, or “V” Ttype Ssign;” shall means those configurations or multiple outdoor advertising device structures, as those terms are commonly understood. In no instance shall these terms include two or more devices which that are not physically contiguous or connected by the same structure or cross-bracing or, in the case of back-to-back or “V” type signs, located more than 45fifteen feet (15’) apart at their nearest points. (See illustrations in Rule 1680-06-03-.09, Appendix.)
- (16) “Erect;” means to construct, build, raise, assemble, place, affix, attain, create, paint, draw, or in any other way bring into being or establish, but does not apply to changes of copy treatment on an existing outdoor advertising device.
- (17) “Facility” means a commercial or industrial facility, or other facility open to public, that operates with regular business hours on a year-round basis within a building or defined physical space, which may include a structure other than a building, together with any immediately adjacent parking areas; provided, that activity conducted in a temporary structure or a structure operated only on a seasonal basis may be considered a facility for the purpose of allowing an on-premises device to be located on the same property, but the device is only allowed on a temporary basis during the period the facility is actually conducting activity.
- ~~Grandfather Non-Conforming Device, means one which was lawfully erected prior to the passage of the state law which is located in a legal area as defined by the law but which does not meet the size, lighting, or spacing criteria as set forth in the Agreement entered into between the Department of Transportation and the Federal Highway Administration which is part of the law.~~
- (18) “Information Ccenter;” means an area or site established and maintained at a Ssafety Rrest Aarea for the purpose of informing the public of places of interest within this State and providing such other information as the Commissioner may consider desirable.
- (19) “Interstate Ssystem;” means that portion of the National System of Interstate and

(Rule 1680-026-03-.02,

Defense Highways located within this State, as officially designated, or as may hereafter be ~~so~~ designated, by the Commissioner, and approved by the Secretary of Transportation of the United States, pursuant to ~~the provisions of~~ Title 23, of the United States Code.

(20) "Main Traveled Way," means the traveled way of a highway on which through traffic is carried. In the case of a divided highway, the traveled way of each of the separated roadways for traffic in opposite directions is a main traveled way. ~~#~~ "Main traveled way" does not include such facilities as frontage roads, turning roadways, parking areas.

(21) "Non-Conforming Device," means ~~one which~~ an outdoor advertising device that was lawfully erected but ~~which does not comply with the provisions of state law or state regulations passed at a later date or which fail to comply with state law or state regulations due to changed conditions~~ conform to the zoning, size, lighting, or spacing criteria established by and in accordance with either the current supplemental agreement entered into between the Department and the Federal Highway Administration on October 16, 1984, or in accordance with the original agreement entered into on November 11, 1971, as authorized in T.C.A. § 54-21-113. Any outdoor advertising device that continues to conform to either the terms of the current supplemental agreement or the original agreement as provided in T.C.A. § 54-21-113 shall not be considered nonconforming.

(22) "Official Signs and Notices," means signs and notices erected and maintained by public officers or public agencies within their territorial or zoning jurisdiction and pursuant to and in accordance with direction or authorization contained in ~~F~~ederal, ~~S~~state, or local law for the purposes of carrying out an official duty or responsibility. Historical markers authorized by state law and erected by ~~S~~state or local government agencies or non-profit historical societies may be considered official signs.

(23) "On-premises device" means a sign:

(a) That is located within fifty feet (50') of, and on the same parcel of property and on the same side of the highway as, the facility (as defined above) that owns or operates the sign or within fifty feet (50') of, and on the same parcel of property and on the same side of the highway as, the entrance to the parcel of property upon which two (2) or more facilities are located; and

(b) For which compensation is not being received and not intended to be received from a third party or parties for the placement of a message on the sign.

(24) "Original conforming device" means a device that was legally permitted on or after April 4, 1972, in accordance with the original agreement entered into between the Department and the Federal Highway Administration on November 11, 1971, as authorized in T.C.A. § 54-21-113(a), and which remains in compliance with the zoning, size, lighting and spacing criteria established in the original agreement.

(25) "Outdoor Advertising Device," ~~means any outdoor sign:~~

(a) Means a sign that is operated or owned by a person or entity that is earning compensation directly or indirectly from a third party or parties for the placement of a message on the sign; and

(b) Does not include a sign that is an on-premises device or other type of sign exempt from regulation under Title 54, Chapter 21, of the Tennessee Code, but does include any other sign not specifically exempted from regulation under the Outdoor Advertising Control Act of 2020 as provided in T.C.A. § 54-21-103, display, device,

(Rule 1680-026-03-.02,

~~bulletin, figure, painting, drawing, message, placard, poster, billboard, or other thing which is used to advertise or inform any part of the advertising or informative contents of which is located within an adjacent area and is visible from any place on the main traveled way of the state, interstate, or primary highway systems.~~

~~Parkland, means any publicly owned land which is designated or used as a public park, recreation area, wildlife or waterfowl refuge, or historic site.~~

(26) "Person," means and includes an individual, a partnership, an association, a corporation, or other entity.

(27) "Primary System," means that portion of connected main highways, located within this State, as officially designated, or as may be hereafter be so designated by the Commissioner, and approved by the Secretary of Transportation of the United States, pursuant to the provisions of Title 23, of the United States Code, including highways designated as part of the national highway system and highways formerly designated as part of the federal-aid primary system.

(28) "Public park" means any publicly owned land which is designated or used as a park, recreation area, wildlife or waterfowl refuge, or historic site.

(29) "Safety Rest Area," means an area or site established and maintained within or adjacent to the right-of-way by or under public supervision or control, for the convenience of the traveling public.

(30) "Scenic Area," or "historic scenic area" means any area of particular scenic beauty or historical significance as determined by the Federal, State, or local officials having jurisdiction thereof and includes interests in lands which have been acquired for the restoration, preservation, and enhancement of scenic beauty or historical resources.

~~Service Club and Religious Notices, means devices and notices, relating to non-profit service clubs, or charitable associations, or religious services.~~

(31) "Sign" means an outdoor sign, light, display, device, figure, painting, drawing, message, placard, poster, billboard, or other thing which is designed, intended, or used to advertise or inform and any part of the advertising or informative contents of which is visible from any place on the main traveled way of an interstate system or primary system; provided, however, that a building, structure, or object having a primary function at its location other than to advertise or inform will not be considered a "sign" solely because words or figures, etc., are displayed on its exterior surface, unless the owner or operator is earning compensation directly or indirectly from a third party or parties for the placement of any message on the exterior of the building, structure, or object and provided that this exception shall not apply to any separate sign structure or sign face that is attached to the building, structure, or object.

(32) "Sign face" means the entire area of a sign used for the display of outdoor advertising. This includes the area normally intended for the display of advertising messages, within and including the border and trim, measured by the smallest square, rectangle, triangle, or circle, or combination thereof, and it also includes any additional area or areas extending outside the normal sign face within which any advertising embellishment or informative content is actually displayed. (See illustration in Rule 1680-06-03-.09, Appendix.)

(33) "Stacked device" means an outdoor advertising device in which two (2) or more displays facing in the same direction of travel along the highway are stacked one (1) above the other in multiple sign faces separated by airspace and regulated together under one permit, as provided in T.C.A. § 54-21-118. (See illustration in Rule 1680-06-03-.09, Appendix.)

(34) "State system" means that portion of highways located within this State, as officially designated.

(Rule 1680-026-03-.02,

or as may hereafter be designated, as state highways by the Commissioner.

(35) "Traveled ~~Way~~," means the portion of a roadway for the movement of vehicles, exclusive of shoulders.

(36) "Unzoned ~~C~~commercial or ~~Unzoned I~~industrial area,"

(a) ~~m~~Means ~~those~~an areas ~~in a political subdivision not comprehensively zoned,~~ on which there ~~are~~is located one (1) or more permanent structures within which a commercial or industrial business is actively conducted, and which ~~are~~is equipped with all customary utilities, facilities and open to the public regularly or regularly used by the employees of the business as their principle work station, or which, due to the nature of the business, is equipped, staffed, and accessible to the public as ~~is customary necessary.~~ Itand includes the area along the highway ~~extended~~ing outward ~~600~~six hundred feet (600') from and beyond the edge of ~~the regularly used area of said~~such activity in each direction and a corresponding zone directly across a primary highway ~~which that~~ is not also a limited ~~or controlled~~ access highway ~~when.~~ All measurements shall be from the edge of the regularly used building, parking lots, storage, or processing area of the commercial or industrial activity, not from the property lines of the activity and shall be along or parallel to the edge of the pavement of the highway. The area created by the 600 foot measurement may not infringe upon a public parkland, public playground, public recreation area, scenic area, cemetery, or upon an the area that is not primarily residential in character or a. The area shall not include land across the highway from a commercial or industrial activity when said highway is an interstate or controlled access primary highway. None of the following, but not limited to the following, shall be considered commercial or industrial activities for the purpose of outdoor advertising:

1. ~~Public park;~~

2. ~~Public playground;~~

3. ~~Public recreational area;~~

4. ~~Public forest, wildlife, or waterfowl refuge;~~

5. ~~Historic scenic area; or~~

6. ~~Cemetery;~~

(b) ~~Does not include land across the highway from a commercial or industrial activity when the highway is an interstate or controlled access primary highway;~~

(c) ~~Must be measured from the outer edges of the regularly used buildings, parking lots, storage, processing, or landscaped areas of the commercial or industrial activity, not from the property lines of the activity}; and~~

(d) ~~Does not include the following activities conducted within the area, when considered for purposes of outdoor advertising:~~

1. ~~e~~Outdoor advertising structures;

2. ~~a~~Agricultural, forestry, ranching, grazing, farming, and related activities, including ~~but not limited to~~ wayside fresh produce stands;

3. ~~t~~Transient or temporary ~~businesses and activities. All businesses and~~

(Rule 1680-026-03-.02,

~~activities that qualify must be established at least 10 months before the location is eligible, (i.e., activities that are not conducted, at least in part, within one or more permanent structures, or activities that are not conducted on a regular schedule for at least five (5) days per week over a continuous period of not less than ten (10) months within a calendar year);~~

~~4. businesses. Activities not recognizable at anytime of the year as a commercial or industrial activity visible from the main traveled way;~~

~~5. aActivities more than ~~660~~six hundred and sixty feet (660') from the nearest edge of the right-of-way;~~

~~6. aActivities conducted in a building ~~principally~~primarily used as a residence; and~~

~~7. rRailroad tracks and minor sidings.~~

~~(e) Note: The six hundred feet (600') feet shall be measured along the edge of the pavement nearest the commercial activity and from points ~~which~~that are perpendicular to the edge of pavement of the traveled way. (See illustration in Rule 1680-06-03-.09, Appendix.)~~

~~(37) "Utility signs" means warning signs, notices, or markers that are customarily erected and maintained for operational and public safety purposes by publicly or privately owned utilities, railroads, ferries, airports, or other entities that provide utility or transportation services.~~

~~(38) "Visible;" means capable of being seen, (whether or not readable), without visual aid by a person of normal visual acuity.~~

~~Void, means a status in which a permit is in violation of at least one requirement of these Rules or governing statutes and such violation cannot or has not been cured within the applicable cure period such that the permit is subject to immediate revocation.~~

~~(39) "Voidable;" means a status in which a permit is in violation of at least one requirement of these Rules or governing statutes and eligible to be rendered void and the outdoor advertising device removed by a final administrative action.~~

~~(40) "Zoned Ccommercial or Zzoned Iindustrial;" means those areas in a comprehensively zoned political subdivision set aside for commercial or industrial use pursuant to the state or local zoning regulations, but shall not include strip zoning, spot zoning, or variances granted by the local political subdivision strictly for outdoor advertising.~~

Authority: T.C.A. §§ ~~54-21-104, 54-21-105, 54-21-103, and 54-21-112, 111, and 54-21-118.~~

Administrative History: Original rule certified June 10, 1974. Repeal and refiled June 9, 1977; effective July 11, 1977. Repeal and new rule filed January 27, 1989; effective March 13, 1989. Amendment filed February 1, 1989; effective March 18, 1989. Public Necessity rule filed August 1, 2006; effective October 1, 2006 through March 15, 2007. Amendment filed December 21, 2006; effective March 6, 2007. Amendment filed September 24, 2008; effective December 8, 2008.

1680-026-03-.03 CRITERIA FOR THE ERECTION AND CONTROL OF OUTDOOR ADVERTISING DEVICES.

(1) Restrictions on ~~O~~outdoor ~~A~~advertising devices within the adjacent area of highways on the to Iinterstate and ~~P~~primary Highwayssystems;

(Rule 1680-026-03-.02,

~~(a) Outdoor Advertising devices erected or maintained within 660 feet of the nearest edge of the right-of-way the adjacent area of a highway on the interstate or primary system and visible from the main traveled way of the highway are subject to the following restrictions: established in T.C.A. § 54-21-103 and as further provided in this rule.~~

~~(a) Measurement of the adjacent area.~~

- ~~1. In general, the measurement of the adjacent area shall begin at the nearest edge of the highway right-of-way property line and continue outward six hundred and sixty feet (660'); provided, however, that:~~
- ~~2. Where the highway right-of-way width extends outward more than one hundred feet (100') from the main traveled way of an interstate or other controlled access highway at an interchange with another highway that is not a controlled access highway, the measurement of the adjacent area beyond the interchange will begin at a line that is one hundred feet (100') outward from, and parallel to, the outside edge line of the through lanes on the main traveled way, excluding shoulders, exit ramps, entrance ramps, and acceleration or deceleration lanes. (See illustration in Rule 1680-06-03-.09, Appendix.)~~

~~(b) Criteria for applying regulations based on visibility from the main traveled way.~~

~~The following criteria will be used to determine whether an outdoor advertising device located within the adjacent area of a highway on the interstate or primary system (regulated highway) should be subject to the restrictions established in this rule because the device has the purpose or effect of directing advertising messages to the main traveled way of the regulated highway:~~

- ~~1. In general, an outdoor advertising device within the adjacent area of a regulated highway is subject to the restrictions established in this rule if fifty percent (50%) or more of the sign face is visible from the main traveled way of the regulated highway.~~
- ~~2. Notwithstanding that fifty percent (50%) or more of the sign face is visible from the main traveled way of a regulated highway, the outdoor advertising device will not be subject to the restrictions applicable to the regulated highway, or it may be subject to restrictions applicable to a different regulated highway, if any of the following factors, or combination of factors, indicate that the device does not have the purpose or effect of directing advertising messages to the main traveled way of the regulated highway:~~
 - ~~(i) The proximate location of the device to another intersecting or parallel highway within the adjacent area of the regulated highway;~~
 - ~~(ii) The size of the sign face in relation to the distance of the device from the regulated highway or other highway;~~
 - ~~(iii) The orientation of the sign face by height or angle in relation to the regulated highway or other highway;~~
 - ~~(iv) The duration of time the sign face is visible from the main traveled way to the driver or passenger of a vehicle traveling at the maximum speed on the regulated highway;~~
 - ~~(v) The use of illumination or a digital display to attract attention to the sign face from the main traveled way of the regulated highway or other highway;~~
 - ~~(vi) The presence of obstructions or seasonal vegetation that blocks visibility of~~

(Rule 1680-026-03-.02,

the sign face for at least six (6) months of the year; or

(vi) Other potentially relevant factors.

3. If application of the factors in part 2 above indicates that the device does not have the purpose or effect of directing advertising messages to the main traveled way of the regulated highway, the device will not be subject to the restrictions applicable to that regulated highway, but will be subject to the restrictions applicable to another regulated highway on the interstate or primary system if the device has the purpose or effect of directing advertising messages to the other regulated highway.

4. If the outdoor advertising device has the purpose or effect of directing advertising messages to two or more regulated highways, the more stringent restrictions applicable to either regulated highway will apply.

4-(c) Zoning restrictions:

Outdoor advertising devices must be located in areas zoned for commercial or zoned industrial use or in areas which qualify for as unzoned commercial or industrial use areas. (See definitions of "unzoned commercial or industrial area" and "zoned commercial or zoned industrial" in Rule 1680-026-03-.02, Paragraph 27.)

(i)2. The following types of advertising signs are not restricted by the zoning criteria:

(i)(i) Directional and other official signs and notices, including directional signs, but not limited to natural wonders, scenic, and historic attractions, which are authorized or required by law;

(ii) Signs, displays, and devices advertising the sale or lease of property on which they are located;

(iii)(ii) Signs, displays, and devices advertising activities conducted on the property on which they are located On-premises devices. (See Rule 1680-026-03-.06 for detailed description of an on-premises sign devices);

(iii) Signs other than outdoor advertising devices that:

(I) Have a sign face that does not exceed twenty square feet (20 sq. ft.) in total area; and

(II) Do not contain any flashing, intermittent, or moving lights;

(iv) Landmark signs lawfully in existence on October 22, 1965, as authorized under 23 U.S.C. § 131 and 23 CFR 750.710; and

(v) Utility signs.

2-(d) Size restrictions:

(i)1. The maximum total gross area for one a sign face on an outdoor advertising structure device, or the total area of the sign faces per horizontal facing on a stacked device or double-faced sign, shall be 775 seven hundred seventy-five square feet (775 sq. ft.), with a maximum height of 30 thirty feet (30') or

(Rule 1680-026-03-.02,

maximum length of ~~60~~sixty feet (60'); provided, however, that ~~(a~~ 60'x30' sign face is not allowed). All measurements of the sign face shall be inclusive of any border and trim, and any advertising embellishments as provided in part 3 below, but exclusive of ornamental base or apron supports and other structural members.

2. In counties having a population greater than 250,000 the ~~state~~Department will accept the particular county's standard size, but in no instance shall this standard size, determined by the local governing body, exceed 1,200 square feet, inclusive of any border and trim and any advertising embellishments but exclusive of ornamental base or apron supports and other standard members.

~~(iii)~~3. The area of each sign face shall be measured by the smallest square, rectangle, triangle, or circle, or combination thereof ~~which that~~ will encompass the entire area of the sign used for the display of outdoor advertising. This includes the area normally intended for the display of advertising messages, within and including the border and trim, measured by the smallest square, rectangle, triangle, or circle, or combination thereof, and it also includes area or areas extending outside the normal sign face within which any advertising embellishment or informative content is actually displayed. In the case of stacked devices or double-faced signs, the total display area of the device will be determined by combining the area of each sign face, measured by the smallest square, rectangle, triangle, or circle, or combination thereof, including the border and trim and the area of any advertising embellishment outside the border and trim but excluding any airspace between the sign faces. (See illustrations in Rule 1680-06-03-.09, Appendix.)

~~(iii)~~4. An outdoor advertising ~~structure~~device may contain one ~~device~~sign face per horizontal facing and may be ~~stacked,~~ back-to-back or V-type, or in the case of a stacked device or double-faced sign the device may contain two (2) or more sign faces per horizontal facing, but the total area of any ~~facing~~sign face, or combination of sign faces, may not exceed ~~775~~seven hundred seventy-five square feet (775 sq. ft.) except as outlined above for counties with a population of 250,000 or greater. In accordance with T.C.A. § 54-21-118, no permits shall be issued for any new stacked devices after July 1, 2001. However, a stacked device legally permitted and erected on or before July 1, 2001, may remain in its location, subject to the annual renewal of the permit, or the holder of the permit may move a lawfully permitted stacked device to a new location if the location is otherwise eligible for a permit.

~~(iv)~~5. ~~Diagrams are included~~See illustrations in the Rule 1680-06-03-.09, Appendix, to this issuance to further describe the size requirements.

~~(v)~~ Size criteria for directional signs is contained in §1680-02-03-.05.

~~(vi)~~6. The following types of advertisingsigns are not subject to size restrictions:

~~(I)~~(i) Signs, displays, and devices advertising the sale or lease of property on which they are locatedOfficial signs and notices, including directional signs;

~~(II)~~(ii) Signs, displays, and devices advertising activities conducted on the property on which they are located (o)n-premises devices);

~~(iii)~~ Landmark signs lawfully in existence on October 22, 1965, as authorized under 23 U.S.C. § 131 and 23 CFR 750.710; and

(Rule 1680-026-03-.02,

(iv) Utility signs.

7. Signs located along a designated scenic highway or parkway are subject to additional size restrictions as provided in T.C.A. §§ 54-17-108 – 54-17-109 and §§ 54-17-205 – 54-17-206.

3-(e) Lighting restrictions:

(i)1. Outdoor advertising devices which that contain, include, have attached, or are illuminated by any flashing, intermittent or moving light, or lights which involve moving parts are prohibited, except that which gives public information, such as time, date, temperature, weather, or similar information changeable message signs with a digital display, as authorized in T.C.A. § 54-21-119 and subparagraph (h) below, or a small digital display, not to exceed one hundred square feet (100 sq. ft.), within a larger non-digital sign face.

(ii)2. Outdoor advertising devices which is that are not effectively shielded so as to prevent beams or rays of light from being directed at any portion of the traveled way of any interstate or Federal-Aid Primary Highway and are of such intensity or brilliance as to cause glare or to impair vision of the driver of any motor vehicle, or which otherwise interferes with any driver's operation of a motor vehicle, are prohibited.

(iii)3. No outdoor advertising device shall be so illuminated that it interferes with the effectiveness of, or obscures an official traffic sign, device, or signal.

4-(f) Spacing restrictions:

(i)1. Interstate Highway Systems and Controlled Access Primary Highways.

(i)(i) No two structures outdoor advertising devices shall be spaced less than one thousand feet (1,000')-feet apart on the same side of the highway on the interstate system or a controlled access highway on the primary system; provided, however, that outdoor advertising devices may be spaced closer together where they are separated by buildings or other obstructions, so that only one (1) outdoor advertising device is visible from the main traveled way of the highway at any one (1) time. The obstruction must be continuous in character; an obstruction caused by a temporary structure or seasonal vegetation will not qualify. (See illustration in Rule 1680-06-03-.09, Appendix.)

(ii)(ii) Outside the corporate limits of a municipality, or in a county having the metropolitan form of government, outside the urban services district, no structure outdoor advertising device may be located adjacent to or within one thousand feet (1,000') of an interchange or intersection at-grade, measured along the interstate or controlled access highway on the primary system from the nearest point of the beginning or ending of pavement widening at the exit or entrance to the main traveled way. Provided, however, that if the boundaries of the urban services district in a county having the metropolitan form of government, overlap the corporate limits of a municipality, located within any such county, then the corporate limits shall be the prevailing factor for determining spacing of structures, rather than the urban services district boundaries. (See

(Rule 1680-026-03-.02,

illustrations in Rule 1680-06-03-.09, Appendix, page 90.)

~~(ii)~~ 2. Primary Highway System (Non-Controlled Access).

~~(i)~~ (i) Outside the corporate limits of a municipality, or in the case of a county having the metropolitan form of government, outside the urban services district, no two ~~structures~~ outdoor advertising devices shall be spaced less than five hundred feet (500') apart on the same side of ~~the~~ highway on the primary system that is not a controlled access highway. Provided, however, that if the boundaries of the urban services district in a county having the metropolitan form of government, overlap the corporate limits of a municipality located within any such county, then the corporate limits shall be the prevailing factor for determining spacing of structures, rather than the urban services district boundaries.

~~(ii)~~ (ii) Within the corporate limits of a municipality, or in the case of a county having the metropolitan form of government, within the urban services district boundaries, no two outdoor advertising devices shall be spaced less than one hundred feet (100') feet apart on the same side of a highway on the primary system that is not a controlled access highway.

~~(iii)~~ Spacing Exceptions

~~With respect to (I) of (i) and (I) and (II) of (ii), structures may be spaced closer together when they are separated by buildings or other obstructions so that only one is visible from the main traveled way within the otherwise applicable spacing requirement at any one time. The applies to both Federal-Aid Interstate and Federal-Aid Primary routes.~~

~~(iv)~~ 3. Explanatory Notes.

With respect to spacing requirements on both the ~~Federal-Aid Interstate~~ and ~~Primary Highway Systems~~:

~~(i)~~ (i) The following types of signs are not subject to spacing requirements, shall not be counted nor shall measurements be made from them for purposes of determining compliance with spacing requirements:

~~I.~~ (I) Directional and other official signs and notices, including directional signs;

~~II.~~ (II) Signs, displays, and devices advertising the sale or lease of the property on which they are located.

~~III.~~ Signs, displays, and devices advertising activities conducted on the property on which they are located. (On-Premise) On-premises devices;

~~(III)~~ Signs other than outdoor advertising devices that:

I. Have a sign face that does not exceed twenty square feet (20 sq. ft.) in total area; and

II. Do not contain any flashing, intermittent, or moving lights;

(Rule 1680-026-03-.02,

(IV) Landmark signs lawfully in existence on October 22, 1965, as authorized under 23 U.S.C. § 131 and 23 CFR 750.710; and

(V) Utility signs.

~~(ii)~~(ii) The minimum distance between outdoor advertising devices shall be measured along the nearest edge of pavement to the outdoor advertising device between points determined by a right angle from the edge of pavement directly opposite and transecting the leading pole of the signs/devices along each side of the highway. (See illustrations in Rule 1680-06-03-.09, Appendix—page 94.)

4. Signs Located Along Scenic Highways or Parkways.

Signs located along a designated scenic highway or parkway are subject to additional spacing restrictions as provided in T.C.A. §§ 54-17-108 – 54-17-109 and §§ 54-17-205 – 54-17-206.

(g) ~~reserved~~Control of Original Conforming Devices.

1. An original conforming device, as defined in Rule 1680-06-03-.02, may remain in place or may be rebuilt, reconstructed, or upgraded, subject to the following restrictions:

(i) A valid permit must be maintained for the device;

(ii) The permit holder must notify and obtain authorization from the Headquarters Highway Beautification Office before rebuilding, reconstructing, or upgrading the device; and

(iii) The device must remain in place or be rebuilt in the exact previous location.

2. A violation of one or more of the restrictions established in part 1 above will render the permit voidable.

3. The Highway Beautification Office shall use its best efforts to review and respond to a request to rebuild, reconstruct, or upgrade an original conforming device within no greater than thirty (30) days after the request is received. If a response cannot be provided within thirty (30) days after receipt of the request, the Highway Beautification Office shall contact the requester prior to the expiration of the thirty (30) days to provide an explanation of the reasons why additional time is needed to review the request.

4. If an original conforming device is removed without prior approval from the Headquarters Highway Beautification Office to rebuild, reconstruct, or upgrade the device, the permit as an original conforming device is voidable and no new permit shall be issued for another outdoor advertising device as an original conforming device at that location.

(h) Changeable Message Signs with a Digital Display.

1. Changeable message signs with a digital display that meet all other requirements pursuant to Title 54, Chapter 21, of the Tennessee Code and these rules are permissible subject to the following restrictions:

(i) The message display time must remain static for a minimum of eight (8)

(Rule 1680-026-03-.02,

seconds with a maximum change time of two (2) seconds;

(ii) Video, continuous scrolling messages, and animation are prohibited; and

(iii) The minimum spacing of the changeable message signs with a digital display facing the same direction of travel on the same side of the interstate system or controlled access highways on the primary system is two thousand feet (2,000'); provided, however, that an outdoor advertising device that uses only a small digital display, not to exceed one hundred square feet (100 sq. ft.) in total area, within a larger non-digital sign face is not subject to the minimum spacing requirement established in this subpart (iii), or to any application for a specific digital display permit or permit addendum, or to any fee for a permit addendum as established in § 54-21-104(b).

2. Brightness standards.

(i) All changeable message signs installed on or after July 1, 2014, must come equipped with a light-sensing device that automatically adjusts the brightness in direct correlation with ambient light conditions.

(ii) The brightness standards and methods for measuring the brightness of a digital display are set forth in T.C.A. § 54-21-119(h), which is incorporated herein by reference, and as described in Rule 1680-06-03-.09, Appendix.

~~1. Application Requirements for New Outdoor Advertising Permits.~~

~~(i) No person shall construct, erect, operate, use, maintain, or cause or permit to be constructed, erected, operated, used or maintained, any outdoor advertising device visible from the main traveled way of the Interstate System, Federal Aid Primary System, or National Highway System and subject to regulation under Title 54, Chapter 21 of the Tennessee Code without first obtaining from the Department a permit and tag authorizing the same. An outdoor advertising device that is erected prior to obtaining the required permit shall be considered illegal and subject to removal at the expense of the owner as provided in Tennessee Code Annotated § 54-21-105.~~

~~(ii) The outdoor advertising permit application form and related forms may be viewed on the Department's Beautification Office website at An original permit application form and related forms may be obtained from any of the following Beautification Offices:~~

~~Headquarters - Beautification Office Suite 400, James K. Polk Bldg.
505 Deaderick Street
Nashville, TN 37243-0333
Telephone No. 615-741-2877
Fax No. 615-532-5995~~

~~Region I - Beautification Office Region II - Beautification Office 7345 Region Lane - P. O. Box 22368~~

~~Knoxville, TN. 37901 - 4005 Cromwell Road
Telephone No. 865-594-2451 Chattanooga, TN. 37422-2368
Fax No. 865-594-6341 Telephone No. 423-892-3430, Ext. 2293
Fax No. 423-899-1636~~

~~Region III - Beautification Office - Region IV - Beautification Office 6601 Centennial Blvd.
- 300 Benchmark Place
Nashville, TN. 37243-0360 - Jackson, TN. 38301-0429
Telephone No. 615-350-4389 Telephone No. 731-935-0170~~

(Rule 1680-026-03-.02,

~~Fax No. 615-350-3966 Fax No. 731-935-0208~~

- ~~(iii) A complete original application for an outdoor advertising permit must be hand delivered or mailed to the Department's Headquarters Beautification Office in Nashville at the address indicated above. No faxed application materials will be accepted.~~
- ~~(iv) In addition to a completed application form, a complete application for an outdoor advertising permit shall also include the following:~~
 - ~~(I) Payment of the application fee by check or money order made payable to the Tennessee Department of Transportation and in the amount established in T.C.A. § 54-21-104 (provided that payment in cash will be accepted if personally delivered to the Headquarters Beautification Office);~~
 - ~~(II) A map or scaled drawing which shows:~~
 - ~~I. The property lines of the real property within which the outdoor advertising device is to be located;~~
 - ~~II. The location of the highway along which the outdoor advertising permit is requested and any other public roads adjacent to the property;~~
 - ~~III. The location and property lines of the State's highway right-of-way;~~
 - ~~IV. The location of the proposed outdoor advertising device within the property; and~~
 - ~~V. The public road, driveway, or other means by which the applicant can obtain access to the real property where the proposed outdoor advertising device is to be located without using direct ingress and egress across or using any part of the state highway right-of-way.~~
 - ~~(III) A signed and notarized affidavit from the property owner (on a form provided by any of the Beautification Offices listed above), as follows:~~
 - ~~I. If the applicant is the property owner or the owner of a permanent easement granting the applicant the right to construct and operate an outdoor advertising device on the property, the affidavit shall:~~
 - ~~A. Certify the applicant's ownership interest in the property; and~~
 - ~~B. Attach a copy of the applicant's most recent property record in the Assessor of Property's Office of the county in which the property is located. If this record is available online, the Department will accept a print-out of this document.~~
 - ~~II. If the applicant is not the property owner or owner of a permanent easement granting the applicant the right to construct and operate an outdoor advertising device on the property, the affidavit shall:~~
 - ~~A. Certify that the property owner has given the applicant permission to construct and operate the proposed outdoor advertising device at the proposed location; and~~
 - ~~B. Attach a copy of the property owner's most recent property record in the Assessor of Property's Office of the county in which the property is located. If this record is available online, the Department will accept a print-out of this document.~~
- ~~(v) The applicant shall mark the proposed location of the outdoor advertising device in the~~

(Rule 1680-026-03-.02,

~~field by placing a stake in the ground, the top of which shall be not less than four (4) feet above ground level, at the precise location on the owner's property where the device is proposed to be located; provided, however, that if the proposed location of the device is in a paved area, the precise location shall be marked on the pavement in paint. The stake or mark shall identify the applicant.~~

~~2. Processing of Applications.~~

- ~~(i) No application for an outdoor advertising permit will be considered unless the completed application form and all other documents required by these Rules have been filed in the Headquarters Beautification Office. An incomplete application will not be considered.~~
- ~~(ii) All documents included with an incomplete application shall be returned to the applicant without being processed, and the application fee shall be returned or refunded. If the incomplete application is accompanied by any other documents pertaining to the permitting of any outdoor advertising device, including without limitation a request to cancel another outdoor advertising permit or the cancellation of a previous request for hearing, the entire package will be returned to the applicant with the incomplete application without being processed.~~
- ~~(iii) If an application is withdrawn or returned for any reason, and the applicant chooses to resubmit the application, the subsequently filed application, if complete, shall be processed as a new application as of the date it is received and shall be given a new application number.~~
- ~~(iv) The return of an incomplete application, and any accompanying materials, without processing in accordance with these Rules is not a final administrative action subject to appeal or an administrative hearing.~~
- ~~(v) Complete applications will be considered on a first come, first served basis and processed in order of time stamped at the Headquarters Beautification Office upon receipt.~~
- ~~(vi) Upon determining that an application is complete, the Headquarters Beautification Office will forward the complete application to the Beautification Office personnel assigned to conduct a field inspection.~~
- ~~(vii) Upon receiving a complete application, the assigned Beautification personnel will initiate a field inspection of the proposed location for the outdoor advertising device.~~
- ~~(viii) If Beautification personnel find that the actual proposed location is not marked on the pavement or staked in the field by a stake as required in these Rules, the Beautification personnel will so notify the Headquarters Beautification Office and the application will be denied. Prior to denying an application, the Beautification personnel will attempt to contact the applicant so that the defect may be cured.~~
- ~~(ix) If Beautification personnel find that the proposed outdoor advertising location would fail to meet the minimum spacing required by law due to a conflict with the location of an earlier filed application, or with the location of an existing permit that the Department has deemed voidable under these Rules, the Beautification personnel shall not complete the field inspection on the later filed application and shall notify the Headquarters Beautification Office that a minimum spacing conflict exists.~~
- ~~(x) Because applications must be considered on a first come, first served basis, the Headquarters Beautification Office shall proceed as follows upon being notified that a minimum spacing conflict exists:~~

(Rule 1680-026-03-.02,

- ~~(I) If an application is submitted for a proposed location that has a minimum spacing conflict with the location proposed in an earlier filed application, the Headquarters Beautification Office shall first determine whether to grant or deny the permit requested in the earlier filed application and proceed as follows:
 - ~~I. If the earlier filed application is granted, the Headquarters Beautification Office shall deny the later filed application.~~
 - ~~II. If the earlier filed application is denied, the later filed application will not be processed until such time as the earlier applicant has an opportunity to request a hearing on the denial and then as follows:
 - ~~A. If the earlier applicant makes a timely request for a hearing, the later filed application, including the application fee and all documents accompanying the application shall be returned to the applicant without processing.~~
 - ~~B. If the earlier applicant does not make a timely request for hearing, the later filed application will be processed and either granted or denied in accordance with these Rules.~~~~~~
- ~~(II) If an application is submitted for a proposed location that has a minimum spacing conflict with the location of an existing outdoor advertising device having a permit that the Department has deemed voidable under these Rules, but which remains in a pending status because the holder of the permit still has the opportunity to undertake remedial action or to request a hearing, or because the holder of the permit has requested a hearing but the case has not been finally adjudicated, the application for the new outdoor advertising permit, including the application fee and all documents accompanying the application, shall be returned to the applicant without processing.~~
- ~~(xi) If the proposed location is properly marked on the pavement or staked in the field and there does not appear to be any minimum spacing conflict with a pending application or permit, Beautification personnel will complete the field inspection in consideration of the zoning, spacing and other requirements for permitting an outdoor advertising device under these Rules.~~
- ~~(xii) Apart from the failure to meet any other requirement of these Rules, if it is determined by the Beautification personnel that the applicant is unable to obtain access to the proposed location to erect and maintain an outdoor advertising device except by direct ingress and egress across the state highway right of way, or by breaching the State's right of access control, if any, or by using some part of the State's right of way, then the application shall be denied.~~
- ~~(xiii) Upon completing the field inspection, Beautification personnel will submit a written field inspection report to the Headquarters Beautification Office.~~
- ~~(xiv) The Headquarters Beautification Office will review the field inspection report for completeness and accuracy. The Headquarters Beautification Office shall make the determination to grant or deny the requested outdoor advertising permit and shall notify the relevant Beautification Office of its decision.~~
- ~~(xv) If the Headquarters Beautification Office grants the permit, a serially numbered permit and metal tag will be issued to the applicant. The permit and metal tag shall be issued only for the specific outdoor advertising sign face identified on the approved application and only for the precise location footprint as marked on the pavement or as staked in the field. Under no circumstances shall a permit and/or tag be used for or moved to~~

(Rule 1680-026-03-.02,

~~any other location.~~

~~(xvi) If the Headquarters Beautification Office decides to deny the permit, the Department will send a copy of the disapproved application to the applicant with a letter explaining the reason for the permit denial. The application fee shall not be refunded.~~

~~3. Requirements for Construction of a Permitted Outdoor Advertising Device.~~

~~(i) If a permit is issued, the permit holder must erect the support structure and attach the sign face at the approved location within one hundred and eighty (180) days from the date the permit is issued. A copy of the approved application must be on-site in the possession of the permit holder, or any person acting on behalf of the permit holder during the construction of the device. If the device is not fully constructed within the one hundred eighty (180) day period, the permit shall be voidable.~~

~~(ii) The dimensions of the sign face on the outdoor advertising device, as built, must conform to the dimensions of the proposed sign face as described in the approved application. If the permit holder does not construct the sign face in accordance with the approved application, the permit shall be voidable.~~

~~(iii) The tag must be affixed to the outdoor advertising device and visible from the main traveled way of the highway on which the outdoor advertising device is permitted. If the tag is not attached and visible as required, the outdoor advertising permit for that device shall be voidable; provided, however, if the growth of vegetation on the highway right-of-way subsequently prevents visibility of the tag from the main traveled way of the highway, the Department may waive this visibility requirement.~~

~~(iv) Neither the permit holder nor any person acting on behalf of the permit holder shall obtain access to the site of the outdoor advertising device by direct ingress and egress across the state highway right of way, nor shall the permit holder or any such person use any part of the State's highway right of way, to erect or maintain the outdoor advertising device. No equipment used by the permit holder or any such person to construct or maintain the outdoor advertising device shall encroach upon the right of way. Removal of any access control fence or any breach of the Department's right of access control is strictly prohibited. If any of these provisions are violated, the permit shall be voidable.~~

~~(v) It is the responsibility of the permit holder to locate the state highway right-of-way property line. No outdoor advertising device shall under any circumstances be allowed on the State's highway right of way. Any outdoor advertising device located partly or entirely on the State's highway right of way shall be considered an encroachment subject to removal at the owner's expense under the provisions of Tennessee Code Annotated~~

~~§ 54-5-136.~~

~~4. Voiding of Permits.~~

~~(i) The Commissioner has the authority to void an outdoor advertising permit under the following conditions:~~

~~(I) Any negligent or intentional misrepresentation of material fact on any application submitted pursuant to these Rules;~~

~~(II) Any violation of one or more of the requirements for a permit under Federal or State law or these Rules.~~

(Rule 1680-026-03-.02,

~~(ii) In the event the Department deems a permit voidable under these Rules, the Department shall give notice either by certified mail or other form of~~

~~return receipt mail or by personal service to the permit holder; provided, however, that notice shall be deemed effective if the permit holder refuses to accept delivery of the certified mail or other return receipt mail. Such notice shall identify the alleged violation that renders the permit voidable; specify the remedial action, if any, which is required to correct the violation; and advise that failure to complete the remedial action within thirty (30) days or to request a hearing to contest the alleged violation within thirty~~

~~(30) days will result in the permit becoming void, the right to a hearing waived, and the outdoor advertising device subject to removal.~~

~~(iii) Once a permit is issued for a location, the Department will not void a permit based on a change in property ownership or the lack of consent of the property owner for the permit owner to operate and maintain an outdoor advertising device at this location unless the permit holder requests that the permit be voided or there is a court order stating, in effect, that the permit holder has no legal right to operate or maintain an outdoor advertising device at that location.~~

~~5. Administrative Hearings.~~

~~(i) If an application for an outdoor advertising permit is processed by the Department and subsequently denied, or if the permit for an existing device has been deemed void or voidable under these Rules, the applicant shall have thirty (30) days from the date of the receipt of the denial letter or notice to request, in writing, an administrative hearing concerning the grounds upon which the permit was denied or is deemed to be voidable. The request for hearing shall state the specific facts and provisions of law upon which the applicant relies to contest the denial or voiding of the permit.~~

~~(ii) If an administrative hearing is requested in the allotted time to contest the denial of an application for a permit, the application shall remain in a pending status until the matter has been finally adjudicated by a final administrative order, a final court order upon judicial review, or by agreement of the parties.~~

~~(iii) If an administrative hearing is requested in the allotted time to contest the grounds upon which the Department has deemed a permit to be voidable, the permit shall not be eligible for renewal and shall be placed in a pending status until the matter has been finally adjudicated by a final administrative order, a final court order upon judicial review, or by agreement of the parties. If the final order or agreement results in reinstatement of the permit, the permit holder shall be responsible for payment of all annual permit renewal back fees from the date of the hearing request. After the back fees are paid, the permit will be returned to active status and shall be eligible for renewal.~~

~~(iv) A hearing on the denial or proposed voiding of an outdoor advertising permit shall be conducted as provided in the Uniform Administrative Procedures Act, Tennessee Code Annotated § 4-5-101, et seq., and the Rules of the Tennessee Department of State, Administrative Procedures Division, Chapter 1360-4-1.~~

~~(v) The return of an application, and any accompanying materials, without processing in accordance with these Rules is not a final administrative action subject to appeal or an administrative hearing. Accordingly, the Department shall not initiate or accept any request for an administrative hearing based on the return of an application or any accompanying materials without processing.~~

~~(vi) The Department has no authority to resolve any dispute between the permit holder~~

(Rule 1680-026-03-.02,

~~and the current property owner concerning the terms of the permit holder's lease or any other claim the permit holder may have to remain on the property. Accordingly, the Department shall not initiate or accept any request for an administrative hearing to resolve any such dispute.~~

~~6. Replacement Tags for Outdoor Advertising Devices:~~

~~Replacements for stolen, vandalized, lost, or illegible tags may be obtained from the Headquarters Beautification Office. Requests for replacement tags must be made in writing and accompanied by a check or money order, payable to the Tennessee Department of Transportation, for the amount of the replacement tag fee as provided in Tennessee Code Annotated § 54-21-104 (provided that payment in cash will be accepted if personally delivered to the Headquarters Beautification Office).~~

~~7. Annual Renewal of Permits for Outdoor Advertising Devices:~~

~~(i) Permits shall be renewed annually between November 1st and December 31st.~~

~~(ii) For each permit that is to be renewed, the permit holder shall return the renewal form together with payment of the annual renewal fee by check or money order made payable to the Tennessee Department of Transportation and in the amount provided in Tennessee Code Annotated~~

~~§ 54-21-104 (provided that payment in cash will be accepted if personally delivered to the Headquarters Beautification Office).~~

~~(iii) The permit holder shall notify the Headquarters Beautification Office of any change in the permit holder's mailing address.~~

~~(iv) Permits and tags shall be voidable on January 1 of each year if not renewed by December 31 of the prior year.~~

~~(v) In the event that a permit holder fails to renew as provided in these Rules, the Department shall notify the permit holder of the violation, as provided in subparagraph (1)(a), part 9(ii) of this Rule. The notice shall state that the permit holder has thirty (30) days after receipt of the notice either to remove the device, request an administrative hearing to contest the violation, or to remedy the violation by applying for a new permit for the same location.~~

~~8. Transfer of Outdoor Advertising Permits.~~

~~(i) If a permit holder chooses to transfer a permit to another company or individual, the transfer request must be in writing and signed by the current permit holder and sent to the Headquarters Beautification Office. It must include a check or money order payable to the Tennessee Department of Transportation for the amount of the transfer fee as provided in Tennessee Code Annotated § 54-21-104 (provided that payment in cash will be accepted if personally delivered to the Headquarters Beautification Office).~~

~~(ii) Permits and tags are issued for a particular sign face and outdoor advertising location and may not be moved to or used for any other location.~~

(2) Restrictions on Outdoor Advertising devices adjacent to Interstate and Primary Highways Systems beyond six hundred sixty feet (660') feet of the nearest edge of the right-of-way outside of urban limits areas are as follows: Effective as of July 1, 1976.

(a) Control of outdoor advertising devices and displays extends to outdoor advertising devices and displays located beyond 660six hundred sixty feet (660') of the nearest edge of the right-of-way of highways on the Federal Aid Interstate

(Rule 1680-026-03-.02,

and ~~P~~primary ~~S~~systems outside of urban areas erected with the purpose of their message being read from the main traveled way of such systems. Such ~~signs, displays, or outdoor advertising~~ devices are prohibited, regardless of whether or not located in commercial or industrial areas, unless they are of a class or type allowed within ~~660~~six hundred sixty feet (660') of the nearest edge of the right-of-way of such systems outside of commercial or industrial areas. To determine whether an outdoor advertising device has been erected for the purpose of having its message read from the main traveled way of a highway on the interstate or primary system, the Department will apply the factors identified in Rule 1680-06-03-.03(1)(b).

(b) Explanatory Notes:

1. An Urban Area, as defined in Title 23, United States Code, Section 101, the term "urban area" means an urbanized area, or in the case of an urbanized area encompassing more than one State, that part of the urbanized area in each such State, or an urban place as designated by the Bureau of the Census having a population of five thousand (5,000) or more and not within any urbanized area, within boundaries to be fixed by responsible State and local officials in cooperation with each other, subject to approval by the Secretary of the United States Department of Transportation. Such boundaries shall encompass, at a minimum, the entire urban place designated by the Bureau of the Census.
2. The term "urbanized area" means an area with a population of fifty thousand (50,000) or more designated by the Bureau of the Census, within boundaries to be fixed by responsible State and local officials in cooperation with each other, subject to approval by the Secretary. Such boundaries shall encompass, at a minimum, the entire urbanized area within a State as designated by the Bureau of the Census.

(3) Landmark Signs.

- (a) Signs lawfully in existence on October 22, 1965, determined by the Commissioner, subject to the concurrence of the Secretary of Transportation of the United States, to ~~be~~ landmark signs, including signs on farm structures, or natural surfaces, of historic or artistic significance, the preservation of which would be consistent with the purposes of this section, are not required to be removed. Landmark signs are exempt from permit and fee requirements.

(b) Explanatory Note:

Reasonable maintenance, repair, and restoration of a landmark sign is permitted. Substantial change in the size, lighting, or message content will terminate its exempt status.

Authority: T.C.A. §§ 54-21-102, ~~54-21-104~~103, ~~54-21-105~~108, ~~and 54-21-112~~111, 54-21-113, 54-21-118, and 54-21-119. Administrative History: Original rule certified June 10, 1974. Repeal and new rule filed June 9, 1977; effective July 11, 1977. Repeal and new rule filed January 27, 1989; effective March 13, 1989. Amendment filed December 21, 2006; effective March 6, 2007. Amendment filed September 24, 2008; effective December 8, 2008.

1680-06-03-.04 PERMITS, RENEWALS, AND ADMINISTRATIVE HEARINGS.

(1) Application Requirements for New Outdoor Advertising Device Permits.

- (a) No person shall construct, erect, operate, use, maintain, or cause or permit to be constructed, erected, operated, used or maintained, any outdoor advertising device

(Rule 1680-026-03-.02,

visible from the main traveled way of the ~~Interstate System, Federal Aid or Primary System, or National Highway System~~ and subject to regulation under Title 54, Chapter 21 of the Tennessee Code, without first obtaining from the Department a permit and tag authorizing the same. An outdoor advertising device that is erected prior to obtaining the required permit shall be considered illegal and subject to removal at the expense of the owner as provided in ~~Tennessee Code Annotated~~ § 54-21-105. The Department shall not require any additional permit under this subparagraph for an outdoor advertising device lawfully permitted, erected, and in operation under the Billboard Regulation and Control Act of 1972 prior to the effective date of the Outdoor Advertising Control Act of 2020.

- (b) The outdoor advertising device permit application form and related forms may be viewed on the Department's Highway Beautification Office website, which can be found at <http://www.tdot.state.us/right-of-way-division.html>. An original permit application form and related forms may be obtained from any of the following Highway Beautification Offices:

Headquarters -- Highway Beautification Office
Suite 400, James K. Polk Bldg.
505 Deaderick Street
Nashville, TN 37243-0333
Telephone No. 615-741-2877
Fax No. 615-532-5995 Email: TDOT.ODA.HBO@tn.gov

Region I - <u>Highway Beautification Office</u> 7345 Region Lane Knoxville, TN- 37904 <u>37914</u> Telephone No. 865-594-2451 <u>Fax No. 865-594-6344</u> <u>Email: TDOT.ODA.HBO@tn.gov</u>	Region II - <u>Highway Beautification Office</u> <u>7512 Volkswagen Drive</u> <u>Chattanooga, TN 37416</u> <u>Telephone No. 423-892-3430, Ext. 2293</u> <u>Telephone No. 423-892-3430, Ext. 2293</u> <u>Email: TDOT.ODA.HBO@tn.gov</u> <u>Fax No. 423-899-1636</u>
--	---

Region III - <u>Highway Beautification Office</u> 6601 Centennial Blvd. Nashville, TN- 37243 <u>0360</u> Telephone No. 615-350-4389 <u>Fax No. 615-350-3966</u> <u>Email: TDOT.ODA.HBO@tn.gov</u>	Region IV - <u>Highway Beautification Office</u> 300 Benchmark Place <u>Jackson, TN- 38301-0429</u> Telephone No. 731-935-0170 <u>Fax No. 731-935-0208</u> <u>Email: TDOT.ODA.HBO@tn.gov</u>
--	--

- (c) A complete original application for an outdoor advertising device permit must be hand delivered or mailed to the Department's Headquarters Highway Beautification Office in Nashville at the address indicated above. No faxed application materials will be accepted.
- (d) In addition to a completed application form, a complete application for an outdoor advertising device permit shall also include the following; provided, however, that an outdoor advertising device that was not subject to regulation under Title 54, Chapter 21, of the Tennessee Code at the time it was erected but has been subsequently brought under such regulation is exempt from the requirements established in parts 2 and 3 of this subparagraph (d), as provided in T.C.A. § 54-21-104:
1. Payment of the application fee by check or money order made payable to the Tennessee Department of Transportation and in the amount established in T.C.A. § 54-21-104 (provided that payment in cash will be accepted if personally delivered to the Headquarters Highway Beautification Office);

(Rule 1680-026-03-.02,

2. A map or scaled drawing ~~which shows that indicates and labels the following:~~
 - (i) The property lines of the real property within which the outdoor advertising device is to be located;
 - (ii) The location of the regulated highway(s) on the interstate or primary system along which the outdoor advertising device permit is requested and any other public roads adjacent to the property;
 - (iii) The location and property lines of the State's highway right-of-way;
 - (iv) The location of the proposed outdoor advertising device within the property; and
 - (v) The public road, driveway, or other means by which the applicant can obtain access to the real property where the proposed outdoor advertising device is to be located without using direct ingress and egress across or using any part of the state highway right-of-way.

3. A signed and notarized affidavit from the property owner or permanent easement owner (on a form provided by any of the Highway Beautification Offices listed above), as follows:
 - (i) If the applicant is the property owner ~~or the owner of a permanent easement granting the applicant the right to construct and operate an outdoor advertising device on the property~~, the affidavit shall:
 - (I) Certify the applicant's ownership interest in the property; and
 - (II) Attach a copy of the applicant's most recent property record in the Assessor of Property's Office of the county in which the property is located. If this record is available online, the Department will accept a print-out of this document. The name of the property owner on the application must match the property owner's name on the affidavit exactly as the name on the property record card; provided, however, that the applicant may submit evidence, e.g., a copy of a deed or bill of sale, demonstrating that the name on the property record is out of date.

 - ~~(ii) If the applicant is the owner of a permanent easement granting the applicant the right to construct and operate an outdoor advertising device on the property, the affidavit shall:~~
 - ~~(I) Certify the applicant's easement interest in the property;~~

 - ~~(II) Attach a copy of the deed granting the applicant a permanent easement right to construct and operate an outdoor advertising device on the property. The name of the easement owner on the application must match the easement owner's name on the affidavit exactly as the easement owner's name on the deed granting the easement; and~~

 - ~~(III) Attach a copy of the most recent property record in the Assessor of Property's Office of the county in which the property is located. If this record is available online, the Department will accept a print-out of this document. Alternatively, the applicant may submit evidence, e.g., a copy of a deed or bill of sale, demonstrating that the name on the~~

(Rule 1680-026-03-.02,property record is out of date.

- (iii) If the applicant is not the property owner or owner of a permanent easement granting the applicant the right to construct and operate an outdoor advertising device on the property, the affidavit shall:
- (I) Certify that the property owner or owner of the permanent easement has given the applicant permission to construct and operate the proposed outdoor advertising device at the proposed location, or that a lessee or other person authorized by the property owner or owner of the permanent easement has given such permission, in which case the applicant shall provide an affidavit jointly signed by the property owner or owner of the permanent easement and the lessee or other person attesting that such permission has been given; and
 - (II) Attach a copy of the property owner's most recent property record in the Assessor of Property's Office of the county in which the property is located. If this record is available online, the Department will accept a print-out of this document. In addition, if applicable, attach a copy of the deed granting the permanent easement right to construct and operate an outdoor advertising device on the property. If the joint affidavit is signed by the property owner, the name of the property owner on the application must match the property owner's name on the affidavit exactly as the name on the property record card; provided, however, that the applicant may submit evidence, e.g., a copy of a deed or bill of sale, demonstrating that the name on the property record is out of date. If the joint affidavit is signed by the owner of the permanent easement, the name of the easement owner on the application must match the easement owner's name on the affidavit exactly as the easement owner's name on the deed granting the permanent easement
- (e) The applicant shall mark the proposed location of the outdoor advertising device in the field by placing a stake in the ground, the top of which shall be not less than four (4) feet above ground level, at the precise location on the owner's property where the device is proposed to be located; provided, however, that if the proposed location of the device is in a paved area, the precise location shall be marked on the pavement in paint. The stake or mark shall identify the applicant. An outdoor advertising device that was not subject to regulation under Title 54, Chapter 21, of the Tennessee Code at the time it was erected but has been subsequently brought under such regulation is exempt from the requirements of this subparagraph (e), as provided in T.C.A. § 54-21-104.
- (2) Processing of Applications.
- (a) No application for an outdoor advertising device permit will be considered unless the completed application form and all other documents required by these Rules have been filed in the Headquarters Highway Beautification Office. An incomplete application will not be considered. It is the applicant's responsibility to verify that all information and documents required for a complete application are accurate and complete.
 - (b) If the application is incomplete or defective on its face, the Highway Beautification Office shall notify the applicant regarding the application's incomplete or defective status no later than fifteen (15) days after receipt of the filed application. The notice shall indicate the information or documentation that is needed to complete or correct

(Rule 1680-026-03-.02,

the application. The notice shall give the applicant a deadline of fifteen (15) days after the date the written notice is sent, or to the end of the next regular business day if the fifteenth (15th) day falls on a weekend or official state holiday, within which to complete or correct the filed application. If the applicant fails to complete or correct the application by the established deadline, the application shall be considered incomplete and shall be returned without further processing, as provided below. The applicant shall be responsible for verifying that the entire application package is accurate and complete, notwithstanding any action or omission by the Department, and the applicant shall not be given a second opportunity to complete or correct the filed application. This shall not be construed to prevent the applicant from submitting a subsequent application for a permit at the same location.

- (bc) All documents included with an incomplete application shall be returned to the applicant without being processed, and the application fee shall be returned or refunded. If the incomplete application is accompanied by any other documents pertaining to the permitting of any outdoor advertising device, including without limitation a request to cancel another outdoor advertising device permit or the cancellation of a previous request for hearing, the entire package will be returned to the applicant with the incomplete application without being processed.
- (ed) If an application is withdrawn or returned for any reason, and the applicant chooses to resubmit the application, the subsequently filed application, if complete, shall be processed as a new application as of the date it is received and shall be given a new application number.
- (ee) The return of an incomplete application, and any accompanying materials, without processing in accordance with these Rules is not a final administrative action subject to appeal or an administrative hearing.
- (ef) Complete applications will be considered on a first come, first served basis and processed in order of time stamped at the Headquarters Highway Beautification Office upon receipt.
- (g) The Highway Beautification Office will use its best efforts to process an application, in accordance with these rules, within no greater than sixty (60) days after receipt of a complete application. If a decision either to issue or deny the permit cannot be made within sixty (60) days, the Highway Beautification Office will contact the applicant prior to the expiration of the sixty (60) days to provide an explanation of the reasons why additional time is needed to process the application.
- (fh) Upon determining that an application is complete, the Headquarters Highway Beautification Office will forward the complete application to the Highway Beautification Office personnel assigned to conduct a field inspection.
- (gi) Upon receiving a complete application, the assigned Highway Beautification Office personnel will initiate a field inspection of the proposed location for the outdoor advertising device.
- (hj) If Highway Beautification Office personnel find that the actual proposed location is not marked on the pavement or staked in the field by a stake as required in these Rules, the Highway Beautification personnel will so notify the Headquarters Highway Beautification Office and the application will be denied. Prior to denying an application, the Highway Beautification Office personnel will attempt to contact the applicant so that the defect may be cured.
- (ik) #The Highway Beautification Office personnel shall complete the field inspection on the later filed application, and if they find that the proposed outdoor advertising device

(Rule 1680-026-03-.02,

location would fail to meet the minimum spacing required by law due to a conflict with the location of an earlier filed application, or with the location of an existing permit that the Department has deemed voidable under these Rules, the Highway Beautification Office personnel shall ~~not complete the field inspection on the later filed application and shall~~ notify the Headquarters Highway Beautification Office that a minimum spacing conflict exists.

(j) Because applications must be considered on a first come, first served basis, the Headquarters Highway Beautification Office shall proceed as follows upon being notified that a minimum spacing conflict exists:

1. If an application is submitted for a proposed location that has a minimum spacing conflict with the location proposed in an earlier filed application, the Headquarters Highway Beautification Office shall first determine whether to grant or deny the permit requested in the earlier filed application and proceed as follows:

(i) If the earlier filed application is granted, the Headquarters Highway Beautification Office shall deny the later filed application.

(ii) If the earlier filed application is denied, the later filed application will not be processed until such time as the earlier applicant has an opportunity to request a hearing on the denial and then as follows:

(I) If the earlier applicant makes a timely request for a hearing, the later filed application, including the application fee and all documents accompanying the application shall be returned to the applicant without processing.

(II) If the earlier applicant does not make a timely request for hearing, the later filed application will be processed and either granted or denied in accordance with these ~~R~~rules.

2. If an application is submitted for a proposed location that has a minimum spacing conflict with the location of an existing outdoor advertising device having a permit that the Department has deemed voidable under these ~~R~~rules, but which remains in a pending status because the holder of the permit still has the opportunity to undertake remedial action or to request a hearing, or because the holder of the permit has requested a hearing but the case has not been finally adjudicated, the application for the new outdoor advertising device permit, including the application fee and all documents accompanying the application, shall be returned to the applicant without processing.

(k) If the proposed location is properly marked on the pavement or staked in the field and there does not appear to be any minimum spacing conflict with a pending application or permit, Highway Beautification Office personnel will complete the field inspection in consideration of the zoning, spacing and other requirements for permitting an outdoor advertising device under these ~~R~~rules.

(l) Apart from the failure to meet any other requirement of these ~~R~~rules, if it is determined by the Highway Beautification Office ~~personnel~~ that the applicant is unable to obtain access to the proposed location to erect and maintain an outdoor advertising device except by direct ingress and egress across the state highway right of way, or by breaching the State's right of access control, if any, or by using some part of the State's right-of-way, then the application shall be denied.

(m) Upon completing the field inspection, Highway Beautification Office personnel will

(Rule 1680-026-03-.02,

submit a written field inspection report to the Headquarters Highway Beautification Office.

- (hp) The Headquarters Highway Beautification Office will review the field inspection report for completeness and accuracy. The Headquarters Highway Beautification Office shall make the determination to grant or deny the requested outdoor advertising permit and shall notify the relevant Highway Beautification Office of its decision.
- (eq) If the Headquarters Highway Beautification Office grants the permit, a serially numbered permit and metal tag will be issued to the applicant. The permit and metal tag shall be issued only for the specific outdoor advertising sign face identified on the approved application and only for the precise location footprint as marked on the pavement or as staked in the field. Under no circumstances shall a permit and/or tag be used for or moved to any other location.
- (pr) If the Headquarters Highway Beautification Office decides to deny the permit, the Department will send a copy of the disapproved application to the applicant with a letter explaining the reason for the permit denial. The application fee shall not be refunded. The applicant shall have a right to appeal the denial of the permit as provided Rule 1680-06-03-.04(8) below.
- (s) If an outdoor advertising device was not subject to regulation under Title 54, Chapter 21, of the Tennessee Code at the time it was erected but has been subsequently brought under such regulation, the Department shall process the application as provided in T.C.A. § 54-21-104(b)(2).
 1. The application must be accompanied by payment of the application fee set in T.C.A. § 54-21-104(b)(2)(C).
 2. The Department shall not deny a permit for an existing outdoor advertising device under this subparagraph (s) solely because the outdoor advertising device does not meet the size, lighting, spacing, or zoning criteria that are required for new outdoor advertising devices under current law and regulations.
 3. An application for a permit may be denied on other grounds under this subparagraph (s) only as otherwise provided in current law or regulations, including as follows:
 - (i) The outdoor advertising device is located within or encroaches upon state highway right-of-way;
 - (ii) There is no access to the outdoor advertising device for maintenance or operational purposes except by direct access from state highway right-of-way or across the state's access control limits;
 - (iii) The applicant for the permit is subject to enforcement action under T.C.A. § 54-21-105(c); or
 - (iv) Issuance of the permit would violate federal law.
 4. If the Department determines that the permit should be denied on any of the grounds provided in part 3 above, the Department will proceed as follows:
 - (i) Before denying the permit, the Department shall notify the applicant in writing of the violation or circumstance that prevents issuance of the permit. The notice shall also give the applicant a reasonable amount of time to undertake such action, if any, that would cure the violation. At a

(Rule 1680-0~~26~~-03-.02,

minimum, the notice shall state that the applicant has forty-five (45) days within which to complete the remedial action or to request an administrative hearing to contest the proposed denial.

- (ii) Upon written request of the applicant, and for good cause shown, the Department may extend the time for completing the remedial action for up to an additional one hundred fifty (150) days, which may be made subject to the condition that the applicant remove all advertising content from the device.
- (iii) If the applicant cures the violation, the Department shall issue the permit, but if the applicant fails to cure the violation, the Department shall deny the permit.

5. Any permit that is issued under this subparagraph (s) must indicate whether the outdoor advertising device is characterized and regulated as a conforming or nonconforming device under these rules based upon the conditions and laws in effect on the date of the Department's field inspection. The Department shall notify the applicant in writing of the reason or reasons for characterizing a device as nonconforming.

6. The applicant has the right to appeal the Department's decision in accordance with this rule and the applicable provisions of the Uniform Administrative Procedures Act, compiled in Title 4, Chapter 5, of the Tennessee Code.

(3) Application Requirements for Changeable Message Signs with a Digital Display.

- (a) A person shall not erect, operate, use, or maintain a changeable message sign with a digital display in a new location without first obtaining a permit and tag expressly authorizing a changeable message sign with a digital display, and annually renewing the permit and tag, as provided in § 54-21-104. The Department shall not require any additional permit under this subparagraph for an outdoor advertising device with a digital display lawfully permitted, erected, and in operation under the Billboard Regulation and Control Act of 1972 prior to the effective date of the Outdoor Advertising Control Act of 2020.
- (b) A person shall not erect, operate, use, or maintain a changeable message sign with a digital display in place of or as an addition to any existing permitted outdoor advertising device without first obtaining, and annually renewing with the permit, an addendum to the permit expressly authorizing a changeable message sign with a digital display in that location as provided in T.C.A. § 54-21-104(b)(3) and this paragraph (3). An outdoor advertising device authorized by a valid permit from the Department that was effective on September 10, 2019, and has been upgraded to a changeable message sign with a digital display between September 11, 2019, and June 22, 2020, the effective date of the Outdoor Advertising Control Act of 2020, is required to apply for an addendum to the permit in accordance with this subparagraph. The Department shall charge an application fee of seventy dollars (\$70.00) for the addendum to the permit and shall process the application in the same manner as provided for an original permit under subparagraph (2)(s).
- (c) The Commissioner shall under no circumstances permit or authorize any person to erect, operate, use, or maintain a changeable message sign of any type as a replacement for or as an addition to any nonconforming outdoor advertising device or in any nonconforming location.
- (d) Notwithstanding any other law to the contrary, a person who is granted a permit or an addendum to a permit authorizing a changeable message sign with a digital display

(Rule 1680-026-03-.02,

in accordance with subparagraphs (a) or (b) has up to, but no more than, twelve (12) months after the date on which the permit or addendum is granted within which to erect and begin displaying an outdoor advertising message on the changeable message sign; provided, however, that prior to the expiration of this twelve-month period, and upon making application to the Commissioner and paying an additional permit fee in the amount of two hundred dollars (\$200), the permit holder may obtain an additional twelve (12) months within which to erect and begin displaying an outdoor advertising message on the changeable message sign. This additional two-hundred-dollar (\$200) fee is separate from any annual permit renewal fee required under § 54-21-104. If the permitted or authorized changeable message sign with a digital display is not erected and displaying a message within the required time, or as extended, the permit or addendum to the permit will be revoked and the changeable message sign with the digital display must be removed by the applicant or subject to removal by the Commissioner as provided in § 54-21-105.

~~Any application for a permit or addendum for a digital display as described in this section may be made using the form for an application for permit for an outdoor advertising device existing on the effective date of this act, until a separate form is available~~

~~(34)~~ Requirements for Construction of a Permitted Outdoor Advertising Device.

- (a) If a permit is issued, the permit holder must erect the support structure and attach the sign face at the approved location within one hundred and eighty (180) days from the date the permit is issued. A copy of the approved application must be on-site in the possession of the permit holder, or any person acting on behalf of the permit holder during the construction of the device. If the device is not fully constructed within the one hundred eighty (180) day period, the permit shall be voidable.
- (b) The dimensions of the sign face on the outdoor advertising device, as built, must conform to the dimensions of the proposed sign face as described in the approved application; provided, however, that upon giving prior written notice thereof to the Headquarters Highway Beautification Office the permittee may construct a sign face with dimensions that are smaller than the dimensions described in the approved application so long as the constructed sign face is at least twenty square feet (20 sq. ft.) in total area and both the sign face and the tag affixed to the device will be visible to the main traveled way of the highway. If the permit holder does not construct the sign face in accordance with the approved application or as modified in accordance with this subparagraph, the permit shall be voidable.
- (c) The tag must be affixed to the outdoor advertising device and visible from the main traveled way of the highway on which the outdoor advertising device is permitted. If the tag is not attached and visible as required, the outdoor advertising permit for that device shall be voidable; provided, however, if after construction of the device the growth of vegetation on the highway right-of-way subsequently prevents visibility of the tag from the main traveled way of the highway, the Department may waive this visibility requirement.
- (d) Neither the permit holder nor any person acting on behalf of the permit holder shall obtain access to the site of the outdoor advertising device by direct ingress and egress across the state highway right-of-way, nor shall the permit holder or any such person use any part of the State's highway right-of-way, to erect or maintain the outdoor advertising device. No equipment used by the permit holder or any such person to construct or maintain the outdoor advertising device shall encroach upon the right-of-way. Removal of any access control fence or any breach of the Department's right of access control is strictly prohibited. If any of these provisions are violated, the permit shall be voidable.
- (e) It is the responsibility of the permit holder to locate the state highway right-of-way

(Rule 1680-026-03-.02,

property line. No outdoor advertising device shall under any circumstances be allowed on the State's highway right-of-way. Any outdoor advertising device located partly or entirely on the State's highway right-of-way shall be considered an encroachment subject to removal at the owner's expense under the provisions of ~~Tennessee Code Annotated~~ § 54-5-136.

(5) Determining the Location of an Outdoor Advertising Device.

(a) For the purposes of issuing permits and regulating outdoor advertising devices in accordance with the Title 54, Chapter 21, of the Tennessee Code and these rules, the location of a permitted outdoor advertising device is determined by the location of the supporting monopole, or by the location of the supporting pole nearest to the highway in the case of a device erected on multiple supporting poles.

(b) Notwithstanding subparagraph (a), if a permitted multiple-pole device may be lawfully reconstructed, the replacement of the supporting poles with a monopole is not considered a change of location requiring a new permit if:

1. The permittee gives advance notice to, and receives the prior approval of, the Department before reconstructing the outdoor advertising device;

2. The monopole is erected within the line segment defined by the previous supporting poles; and

3. The location of the monopole meets applicable spacing requirements.

(46) Voiding of Permits.

(a) The Commissioner has the authority to void an outdoor advertising device permit under the following conditions:

1. Any negligent or intentional misrepresentation of material fact on any application submitted pursuant to these ~~R~~rules; or

2. Any violation of one or more of the requirements for a permit under Federal or State law or these ~~R~~rules.

(b) In the event the Department deems a permit voidable under these ~~R~~rules, the Department shall give notice either by certified mail or other form of return receipt mail or by personal service to the permit holder; provided, however, that notice shall be deemed effective if the permit holder refuses to accept delivery of the certified mail or other return receipt mail. Such notice shall identify the alleged violation that renders the permit voidable; specify the remedial action, if any, which is required to correct the violation; and advise that failure to complete the remedial action within ~~thirtyfourty-five (3045)~~ days or to request a hearing to contest the alleged violation within ~~thirtyfourty-five (3045)~~ days will result in the permit becoming void, the right to a hearing waived, and the outdoor advertising device subject to removal and other enforcement action under T.C.A. § 54-21-105.

(c) Once a permit is issued for a location, the Department will not void a permit based on a change in property ownership or the lack of consent of the property owner for the permit owner to operate and maintain an outdoor advertising device at this location unless the permit holder requests that the permit be voided or there is a court order stating, in effect, that the permit holder has no legal right to operate or maintain an outdoor advertising device at that location.

(7) Investigations.

(Rule 1680-026-03-.02,

- (a) If the Department has reason to believe that a sign is being operated, in whole or part, as an outdoor advertising device without first obtaining a permit as required under T.C.A. § 54-21-104, the Department may issue an investigative request to the owner or operator of the sign, the owner of the property, or any other person for the purpose of obtaining relevant documents or information to determine whether the sign is being operated as an outdoor advertising device.
- (b) If, after being served with an investigative request by the Department under Subparagraph (a), the person provides the requested documents or information and the Department determines that the sign is being operated as an outdoor advertising device in violation of T.C.A. §§ 54-21-103 and 54-21-104, the Department shall issue a written order to the owner or operator of the outdoor advertising device explaining the basis for determining that the sign is an outdoor advertising device and directing the owner or operator of the device to remedy the violation by applying for the applicable outdoor advertising device permit, or by removing the unlawful device, as appropriate, by the date set forth in the order, which shall be no less than sixty (60) days after the date of the order.
- (c) The person may appeal the Department's order under subparagraph (b) by filing a written notice of appeal with the Department within thirty (30) days of the date on which the order is issued. If an appeal is timely filed with the Department, the Department shall initiate a contested case proceeding under the Uniform Administrative Procedures Act, compiled in Tennessee Code Annotated, Title 4, Chapter 5, to hear the person's appeal.
- (d) If a person fails to comply with the Department's investigative request under subparagraph (a), or if the Department reasonably believes the documents or information provided are incomplete or inaccurate, the Department may initiate a contested case proceeding under the Uniform Administrative Procedures Act to compel the production of relevant documents or information and to determine whether the outdoor advertising device is being operated in violation of §§ 54-21-103 and 54-21-104 and therefore subject to enforcement action under § 54-21-105.

~~(58)~~ Administrative Hearings.

- (a) If an application for an outdoor advertising device permit is processed by the Department and subsequently denied, or if the permit for an existing device has been deemed ~~void or~~ voidable under these ~~R~~rules, the applicant shall have ~~thirtyfourty-five~~ (3045) days from the date of the receipt of the denial letter or notice to request, in writing, an administrative hearing concerning the grounds upon which the permit was denied or is deemed to be voidable. The request for hearing shall state the specific facts and provisions of law upon which the applicant relies to contest the denial or voiding of the permit.
- (b) If an administrative hearing is requested in the allotted time to contest the denial of an application for a permit, the application shall remain in a pending status until the matter has been finally adjudicated by a final administrative order, a final court order upon judicial review, or by agreement of the parties.
- (c) If an administrative hearing is requested in the allotted time to contest the grounds upon which the Department has deemed a permit to be voidable, the permit shall not be eligible for renewal and shall be placed in a pending status until the matter has been finally adjudicated by a final administrative order, a final court order upon judicial review, or by agreement of the parties. If the final order or agreement results in reinstatement of the permit, the permit holder shall be responsible for payment of all annual permit renewal back fees from the date of the hearing request. After the back

(Rule 1680-026-03-.02,

fees are paid, the permit will be returned to active status and shall be eligible for renewal.

- (d) A hearing on the denial or proposed voiding of an outdoor advertising device permit shall be conducted as provided in the Uniform Administrative Procedures Act, Tennessee Code Annotated § 4-5-101, et seq., and the Rules of the Tennessee Department of State, Administrative Procedures Division, Chapter 1360-04-01.
- (e) The return of an application, and any accompanying materials, without processing in accordance with these ~~R~~rules is not a final administrative action subject to appeal or an administrative hearing. Accordingly, the Department shall not initiate or accept any request for an administrative hearing based on the return of an application or any accompanying materials without processing.
- (f) The Department has no authority to resolve any dispute between the permit holder and the current property owner concerning the terms of the permit holder's lease or any other claim the permit holder may have to remain on the property. Accordingly, the Department shall not initiate or accept any request for an administrative hearing to resolve any such dispute.

~~(69)~~ Replacement Tags for Outdoor Advertising Devices: ~~;~~

Replacements for stolen, vandalized, lost, or illegible tags may be obtained from the Headquarters Highway Beautification Office. Requests for replacement tags must be made in writing and accompanied by a check or money order, payable to the Tennessee Department of Transportation, for the amount of the replacement tag fee as provided in ~~Tennessee Code Annotated~~T.C.A. § 54-21-104 (provided that payment in cash will be accepted if personally delivered to the Headquarters Highway Beautification Office).

~~(710)~~ Annual Renewal of Permits for Outdoor Advertising Devices: ~~;~~

- (a) Permits shall be renewed annually between November 1st and December 31st.
- (b) For each permit that is to be renewed, the permit holder shall return the renewal form together with payment of the annual renewal fee by check or money order made payable to the Tennessee Department of Transportation and in the amount provided in ~~Tennessee Code Annotated~~T.C.A. § 54-21-104 (provided that payment in cash will be accepted if personally delivered to the Headquarters Highway Beautification Office).
- (c) The permit holder shall notify the Headquarters Highway Beautification Office of any change in the permit holder's mailing address.
- (d) Permits and tags shall be voidable on January 1 of each year if not renewed by December 31 of the prior year.
- (e) In the event that a permit holder fails to renew a permit as provided in these ~~R~~rules, ~~the Department shall notify the permit holder of the violation, as provided in subparagraph (1)(a), part 9(ii) of this Rule. The notice shall state that the permit holder has thirty (30) days after receipt of the notice either to remove the device, request an administrative hearing to contest the violation, or to remedy the violation by applying for a new permit for the same location. permit will not be considered void until the Department has given the permit holder notice of the failure to renew and the opportunity to correct the unlawfulness, as provided in T.C.A. §54-21-105(b). The Department must send the notice of the failure to renew within sixty (60) days after the failure to renew. The failure to renew may be remedied by submitting a late renewal form and paying the annual permit renewal fee together with a late fee, in the total amount of two hundred dollars~~

(Rule 1680-026-03-.02,

(\$200), within one hundred twenty (120) days of receipt of the notice. If a permit holder fails to renew the permit within this one hundred twenty (120) day notice period, then the permit is void and the outdoor advertising device is considered unlawful and subject to removal as further provided in T.C.A. § 54-21-105. The notice given by the Department must include the requirements for renewal and consequences of failure to renew as provided in this subparagraph (e).

~~(811)~~ Transfer of Outdoor Advertising Device Permits.

- (a) If a permit holder chooses to transfer a permit to another company or individual, the transfer request must be in writing and signed by the current permit holder and sent to the Headquarters Highway Beautification Office. It must include a check or money order payable to the Tennessee Department of Transportation for the amount of the transfer fee as provided in ~~Tennessee Code Annotated~~ T.C.A. § 54-21-104 (provided that payment in cash will be accepted if personally delivered to the ~~Headquarters Highway~~ Beautification ~~Office~~).
- (b) Permits and tags are issued for a particular sign face and outdoor advertising device location and may not be moved to or used for any other location.

Authority: T.C.A. §§ 54-21-104, 54-21-105, and 54-21-111.

~~1680-026-03-.04.05 CONTROL OF NON-CONFORMING AND GRANDFATHERED NON-CONFORMING OUTDOOR ADVERTISING DEVICES ALONG THE INTERSTATE AND PRIMARY SYSTEM OF HIGHWAYS.~~

- (1) Those outdoor advertising devices legally in existence on April 4, 1972, shall be entitled to remain in place and in use until compensation for removal has been made.
- (2) ~~Grandfathered non-conforming devices as defined in § 1680-02-03-.02, paragraph 11, and n~~ Nonconforming devices as defined in §Rule 1680-026-03-.02, paragraph 15, may remain in place, subject to restrictions set forth herein, until such time as they may be purchased.
- (a3) Restrictions on non-conforming ~~and grandfathered non-conforming~~ devices are as follows:
 - 1-(a) Maintenance beyond customary maintenance will not be allowed. Customary maintenance is defined ~~as the replacement of the sign face or stringers, but not the replacement of any pole, post, or support structure in Rule 1680-06-03-.02.~~ Customary maintenance may include, but shall not exceed, the replacement of the sign face and stringers in like materials, and the replacement in like materials of up to fifty percent (50%) of the device's poles, posts, or other support structures; provided, that the replacement of any poles, posts, or other support structures is limited to one (1) time within a twenty-four-month period.
 - 2-(b) Under no circumstances may the location be changed.
 - 3-(c) Extension or changing height above ground level or enlargement of the sign face will not be allowed.
 - 4-(d) Lighting cannot be added to an unilluminated sign.
 - 5-(e) Reflective material cannot be added to a ~~n unreflectorized non-reflective~~ sign.
- (4) A lawfully permitted non-conforming device ~~or grandfathered non-conforming device~~ that

(Rule 1680-026-03-.02,

has been destroyed or damaged beyond what may be repaired through customary maintenance may be rebuilt or repaired beyond customary maintenance only if all of the following conditions are satisfied:

- (a) The destruction of or damage to the device must have been caused by vandalism or some other criminal or tortious acts, excluding any negligent or intentional acts of the permit holder or any party acting by permission of, with the knowledge of, or in concert with the permit holder and/or sign owner.
- (b) No device may be rebuilt and/or repaired without the prior written approval of the Regional Highway Beautification Office for the administrative region of the ~~Tennessee~~ Department of ~~Transportation~~ in which the device is located.
- (c) The current holder of the permit or sign owner, if different, must submit a written request for approval to the appropriate Regional Highway Beautification Office, which written request must provide, at a minimum:
 1. Proof of the date and cause of the destruction of and/or damage to the device, including a copy of the police report made with respect to the vandalism or other criminal or tortious act causing such destruction or damage; and
 2. A general description of the manner in which it is proposed to rebuild and/or repair the device.
- (d) No post, pole or other support structure, or any component of the device other than the sign face or stringers, will be approved for replacement or repair without proof that such post, pole, support structure, or other component of the device was destroyed or damaged by an act of vandalism or some other criminal or tortious act. The replacement or repair of destroyed components of the device under this subparagraph is separate and distinct from, and does not operate as limitation of, the provision for customary maintenance of such devices.
- (e) The device must be rebuilt and/or repaired in such manner that it replicates the original device, including specifically as follows:
 1. The rebuilt and/or repaired device must remain or be rebuilt in the exact same location as the original device; and
 2. The rebuilt and/or repaired device must have the same height, size, and dimensions as the original device; and
 3. Each post, pole, other support structure, or other component of the device, including the sign face and stringers, must be rebuilt and/or repaired with materials that replicate the materials used to construct that same component in the original device (e.g., wood for wood, steel for steel, etc.); and
 4. No component may be added to the rebuilt device that was not permitted under the original device, including no lighting if the original sign was not illuminated, no reflective material if the original sign was not reflectorized, and no changeable message technology on the sign face if not included on the original sign.
- (f) The rebuilding and/or repair of the device must be completed within twelve (12) months after the date on which the original device was destroyed and/or damaged or the device will be treated as an abandoned outdoor advertising

(Rule 1680-026-03-.02,

device. Permittee must contact the Regional Highway Beautification Office for field inspection once rebuilding or repair has been completed.

(45) Except as provided in ~~p~~Paragraph (24) of this rule above, any previously permitted nonconforming device ~~or grandfathered non-conforming device~~ that is destroyed by natural disaster, natural attrition, or any other cause whatsoever shall not continue to be permitted under this Chapter.

(6) See illustrations at Rule 1680-06-03-.09, Appendix, for further descriptions of damaged nonconforming devices that are qualified for customary maintenance and destroyed nonconforming devices that are subject to removal.

Authority: T.C.A. §§ 54-21-102, 54-21-442111, and 54-21-120. Administrative History: Original rule certified June 10, 1974. Repealed and refiled June 9, 1977; effective July 11, 1977. Repeal and new rule filed January 27, 1989; effective March 13, 1989. Amendment filed February 1, 1989; effective March 18, 1989. Public Necessity rule filed March 13, 1989. Amendment filed February 1, 1989; effective March 18, 1989. Public Necessity rule filed August 1, 2006; effective October 1, 2006 through March 15, 2007. Amendment filed December 21, 2006; effective March 6, 2007.

~~1680-02-03-.05 DIRECTIONAL SIGNS. Directional devices must meet the following criteria:~~

~~Directional Signs shall not exceed the following size limits:~~

~~Maximum area—150 square feet~~

~~Maximum height—20 feet~~

~~Maximum length—20 feet~~

~~All dimensions include border and trim, but exclude supports.~~

~~The lighting requirements are explained in §1680-02-03-.03.~~

~~Spacing of Directional Signs:~~

~~Each location of a directional sign must be approved by the Department.~~

~~No directional sign may be located within 2000 feet of an intersection or interchange at grade measured along the interstate system or controlled access highway. Measurement shall be made from the nearest point of the beginning or ending of pavement widening at the exit from or entrance to the main traveled way.~~

~~No directional sign may be located within 2000 feet of a rest area, parkland, or scenic area.~~

~~No two directional signs facing in the same direction of travel shall be spaced less than one (1) mile apart:~~

~~Not more than three (3) directional signs pertaining to the same activity facing the same direction of travel shall be erected along a single route approaching the activity.~~

~~Signs located adjacent to the Interstate System shall be within 75 air miles of the activity.~~

~~Signs located adjacent to the Primary System shall be within 50 air miles of the activity.~~

~~Message Content—Directional Signs~~

~~The message on directional signs shall be limited to the identification of the attraction or activity and directional information useful to the traveler in locating the attraction, such as mileage, route~~

~~(Rule 1680-026-03-.02, numbers, and exit numbers. Descriptive words or phrases and pictorial or photographic representations of the activity or its environs are prohibited.~~

~~Selection Methods and Criteria~~

~~In determining whether privately owned attractions or activities can be eligible for directional signing the following must be met:~~

~~The site must fall into one of the categories as listed in §1680-02-03-.02, paragraph 8.~~

~~The attraction or activity must document that it is nationally or regionally known in the Southeastern United States.~~

~~It must be determined that the activity or attraction is of outstanding interest to the traveling public.~~

~~All applications for directional signing must be submitted to the Highway Beautification Headquarters Office in Nashville, Tennessee, whose personnel will determine eligibility.~~

~~If an application is approved, a metal identification tag will be issued at no cost to the sign owner. This tag will be displayed on the pole nearest the highway, at least four (4) feet off the ground and visible from the highway. This tag is a permanent identification of the sign.~~

~~The following directional devices are prohibited:~~

~~Signs advertising activities that are illegal under Federal or State Laws or regulations in effect at the location of such devices or at the location of such activities.~~

~~Devices located in such manner as to obscure or otherwise interfere with the effectiveness of an official traffic sign, signal or device, or obstruct or interfere with the driver's view of approaching, merging, or intersecting traffic.~~

~~Devices which are erected or maintained upon trees or painted or drawn upon rocks or other natural features.~~

~~Obsolete signs.~~

~~Devices which are structurally unsafe or in disrepair.~~

~~Devices which move or have any animated or moving parts.~~

~~Devices located in rest areas, parklands, or scenic areas.~~

~~Civic or Service Club Signs~~

~~Any civic or service club sign that is requested shall be approved by the Regional Engineer. Such requests shall be rejected if they encroach any primary or interstate right of way.~~

~~Criteria for civic or service signs are as follows:~~

~~The sign must be no larger than eight (8) square feet.~~

~~The message must pertain only to a religious, charitable, or civic organization.~~

~~Such signs will not be placed in any intersection or in any other location that would block sight distance.~~

~~Authority: T.C.A. § 54-21-112. Administrative History: Original rule certified June 10, 1974. Repeal and new rule filed June 9, 1977;~~

(Rule 1680-026-03-.02,

~~effective July 11, 1977. Repeal and new rule filed January 27, 1989;
effective March 13, 1989. Amendment filed December 21, 2006; effective March 6, 2007.~~

1680-026-03-.06 ON-PREMISES ~~S~~ SIGNS ~~S~~ DEVICES.

(1) General

(a) ~~Signs advertising the sale or lease of the property on which they are located and signs advertising activities conducted on the property upon which they are located are called "on-premise" signs. These are not required to be permitted as discussed in §1680-02-03-.03, 5. And 6., but are subject to the criteria listed below when determining whether a sign is an on-premise sign. On-premises devices are not subject to the zoning, size, lighting, or spacing regulations set out in Rule 1680-06-03-.03 or to the permitting requirements established in Rule 1680-06-03-.04. However, on-premises devices located along a designated scenic highway or parkway are subject to additional size and spacing restrictions as provided in T.C.A. §§ 54-17-108 – 109 and §§ 54-17-205 – 54-17-206.~~

(b) ~~To qualify as an on-premises device, a sign must meet the following requirements, as provided in the definitions set out in Rule 1680-06-03-.02, and as further detailed in subparagraphs (2) and (3), below:~~

1. ~~The sign must be located~~

(i) ~~Within fifty feet (50') of, and on the same parcel of property and on the same side of the highway as, the facility that owns or operates the sign; or~~

(ii) ~~Within fifty feet (50') of, and on the same parcel of property and on the same side of the highway as, the entrance to the parcel of property upon which two (2) or more facilities are located; and, provided that:~~

(iii) ~~For the purpose of applying this rule, the facility on or next to which an on-premises device is located must be:~~

(I) ~~A commercial or industrial facility, or other facility open to the public, that operates with regular business hours on a year-round basis within a building or defined physical space, which may include a structure other than a building, together with any immediately adjacent parking areas, except that~~

(II) ~~An activity conducted in a temporary structure or a structure operated only on a seasonal basis may be considered a facility for the purpose of allowing an on-premises device to be located on the same property, but the device is only allowed on a temporary basis during the period the facility is actually conducting activity; and~~

2. ~~The owner or operator of the sign or the facility must not be receiving or intend to receive compensation from a third party or parties for the placement of a message or messages on the sign.~~

~~Characteristics of an On-Premise Sign~~

~~A sign will be considered to be an on-premise sign if it meets the following requirements.~~

~~Premise—The sign must be located on the same premises as the activity or property~~

(Rule 1680-026-03-.02,
~~advertised.~~

~~Purpose—The sign must have as its purpose (1) the identification of the activity, or its products or services, or (2) the sale or lease of the property on which the sign is located, rather than the purpose of general advertising.~~

(2) Premises Test

To qualify as an on-premises device, a sign must be on, or within fifty feet (50') of, the premises of the facility (i.e., the building or defined physical space, which may include a structure other than a building, together with any adjacent parking area), where the activities of the facility are conducted. The following criteria shall be used in determining whether a device is located on the ~~same~~ premises ~~as the activity or property advertised~~ of the facility:

- (a) The premises on which an activity is conducted is determined by physical facts rather than property lines. Generally, it is defined as the land occupied by the buildings or other physical uses essential to the activity, including such areas as are arranged and designed to be used in connection with such buildings or uses.
- (b) The following will not be considered ~~to be~~ a part of the premises on which the activity is conducted, and any signs located on such land will be considered “off-premises” ~~advertising signs~~:
 1. Any land ~~which that~~ is not used as an integral part of the ~~principle principal~~ activity. This ~~would~~ includes but is not limited to, land ~~which that~~ is separated from the activity, by a roadway, highway, or other obstructions and not used ~~by to conduct~~ the activity ~~and/or land consisting of~~ extensive undeveloped highway frontage ~~contiguous to the land not~~ actually used ~~a commercial by the facility to conduct the activity~~ even though ~~the land~~ might be under the same ownership:-
 2. Any land ~~which that~~ is used for, or devoted to, a separate purpose unrelated to the ~~advertised principal~~ activity. For example, land adjacent to or adjoining a service station, but devoted to raising of crops, ~~a~~ residence, or farmstead uses or other than commercial or industrial uses having no relationship to the service station activity would not be part of the premises of the service station, even though under the same ownership:- or
 3. Any land ~~which that~~ is:
 - (i) ~~a~~At some distance from the ~~principle principal~~ activity, and
 - (ii) ~~i~~In closer proximity to the highway than the ~~principle principal~~ activity, and
 - (iii) ~~e~~Developed or used only in the area of the sign site or between the sign site and the ~~principle principal~~ activity, and
 - (iv) ~~e~~Occupied solely by structures or uses which are only incidental to the ~~principle principal~~ activity, and which serve no reasonable or integrated purpose related to the activity other than to attempt to qualify the land for on-premises signing purposes. Generally, these will be facilities such as picnic, playground, or camping areas, dog kennels, golf driving ranges, skeet ranges, common or private roadways or easements, walking paths, fences, and sign maintenance sheds.

(Rule 1680-026-03-.02,

(c) Narrow Strips

Where the sign site is located at or near the end of a narrow strip contiguous to the ~~advertised~~ activity, the sign site shall not be considered part of the premises ~~on which the activity being advertised is conducted~~ of the facility. A narrow strip shall include any configurations of land ~~which is such that it cannot be put to any reasonable use related to the activity other than for signing purposes~~. In no event shall a sign site be considered part of the premises on which the ~~advertised~~ activity is conducted if it is located upon a narrow strip of land:

1. Which is non-building land, such as swamp land, marsh land, or other wet land, or
2. Which is a common or private roadway, or
3. Held by easement or other lesser interest than the premises where the ~~advertised~~ activity is located.

Note: On-premises ~~advertising devices~~ may extend up to fifty ~~feet~~ (50') ~~feet~~ from the ~~principle~~ principal activity as set forth above unless the area extends across a roadway.

(d) See illustration in Rule 1680-06-03-.09, Appendix, for further description of the location requirements for an on-premises device.

~~(1) Purpose Test~~

~~The following criteria shall be used for determining whether a sign has as its purpose (1) the identification of the activity located on the premises or its products or services, or (2) the sale or lease of the property on which the sign is located, rather than the business of outdoor advertising.~~

~~(a) General~~

- ~~1. Any sign which consists solely of the name of the establishment is an on-premise sign.~~
- ~~2. A sign which identifies the establishment's principle or accessory product or services offered on the premises is an on-premise sign.~~
- ~~3. An example of an accessory product would be a brand of tires offered for sale at a service station.~~

(3) Business of Outdoor Advertising

(a) When an outdoor advertising device A sign shall not be considered an on-premises device, notwithstanding the location of the sign, and shall be considered an outdoor advertising device, if it is operated to earn compensation directly or indirectly from a third party or parties for the placement of a message on the sign, (1) brings rental income to the property owner, or (2) consists principally of brand name or trade name advertising, or (3) the product or service advertised is only incidental to the principle activity, it shall be considered the business of outdoor advertising and not an on-premise sign. An example would be a typical billboard located on the top of a service station building that advertised a brand of cigarettes or chewing gum which is incidentally sold in a vending machine on the property.

(Rule 1680-026-03-.02,

~~(b) An outdoor advertising device which advertises activities conducted on the premises, but which also advertises, in a prominent manner, activities not conducted on the premises, is not an on-premise sign. An example would be a sign advertising a motel or restaurant not located on the premises with a notation or attachment stating "Skeet Range Here," or "Dog Kennels Here." The on-premise activity would only be the skeet range or dog kennels. In the case of a property on which two (2) or more facilities are located, a sign located at the entrance of the property, as provided in subpart (1)(b)1(ii) of this rule, will not be considered an outdoor advertising device operated to earn compensation directly or indirectly from a third party for the placement of a message on the sign so long as:~~

- ~~1. The owner or operator of the sign does not receive compensation for the display of a message from any person other than a facility that is located on the same property; and~~
- ~~2. The facility located on the property does not receive compensation from any other person for the display of a message on the sign located on the same property;~~

~~(b) Sale or Lease Signs~~

~~A sale or lease sign which also advertises any product or service not located upon and related to the business of selling or leasing the land on which the sign is located is not an on-premise sign. An example of this would be a typical billboard which states "THIS PROPERTY FOR SALE--- SMITHS MOTEL; 500 ROOMS, AIR CONDITIONED, TURN RIGHT 3 BLOCKS AT MAIN STREET."~~

Authority: T.C.A. §§ ~~54-21-23102, 54-21-103, and 54-21-111~~; and U.S.C. §131. Administrative History: Original rule certified June 10, 1974. Repeal and new rule filed June 9, 1977; effective July 11, 1977. Repeal and new rule filed January 27, 1989; effective March 13, 1989.

1680-026-03-.07 -REMOVAL OF ABANDONED ~~SIGNS~~DEVICES.

~~(1) The permit for an abandoned outdoor advertising device shall be voidable after a twelve-month period of abandonment has elapsed-. , as follows:~~

- ~~(a) The permit for a device, or permits for a device with multiple sign faces, that for a period of twelve (12) months remains in substantial need of repair, which in the case of a wooden sign structure means that sixty percent (60%) or more of the upright supports of the sign structure are physically damaged such that normal repair practices would call for replacement of the broken supports or in the case of a metal sign structure that normal repair practices would call for replacement of at least thirty percent (30%) of the length above ground of each broken, bent, or twisted support, is voidable after the device has remained in that condition for a period of twelve (12) months; provided, however, that a nonconforming device in a condition meeting these criteria will immediately be considered destroyed rather than abandoned and the permit for the device will be void;~~
- ~~(b) The permit for a device whose sign face remains damaged fifty percent (50%) or more, or in the case of a device with multiple sign faces, the permit for each sign face that remains damaged fifty percent (50%) or more, is voidable after the sign face has remained in that condition for a period of twelve (12) months;~~
- ~~(c) The permit for a device that has a blank sign face (i.e., no advertising message),~~

(Rule 1680-026-03-.02,

or in the case of a device with multiple sign faces, the permit for each sign face that remains blank, is voidable after the sign face has remained in that condition for a period of twelve (12) months; or

(d) The permit for a device that has been removed from its permitted location is voidable if it has not been reconstructed in its permitted location within twelve (12) months after its removal; provided, however, that a nonconforming device that has been removed will immediately be considered destroyed rather than abandoned and the permit for the device will be void.

(2) The twelve-month period for establishing abandonment under subparagraphs (1)(a) – (d) may be waived or suspended during a period of involuntary discontinuance, such as the closing of a highway for repair in front of the sign; provided, however, that the termination of the permit holder’s lease, easement, or other right or permission for access from the landowner shall not be grounds for waiver of the twelve-month period for establishing abandonment.

(3) An abandoned outdoor advertising device or sign face that no longer has an outdoor advertising permit is subject to removal or other enforcement action as provided in T.C.A. § 54-21-105.

(4) Before initiating an enforcement action based on abandonment, the Department will first send a written notice to the permit holder identifying the condition of the device that would constitute abandonment and the date on which the twelve-month period for establishing abandonment will begin. If the permit holder believes that a defense to the condition of abandonment exists, the permit holder shall notify the Department in writing, and the Department shall respond in writing. If the Department does not accept the defense and the condition of abandonment remains for twelve (12) months, the Department will send a written notice to the permit holder, as provided in Rule 1680-06-03-.04(6)(b), stating that the permit is voidable based on abandonment. The permittee shall have forty-five (45) days within which to appeal the decision, as provided in Rule 1680-06-03-.04(6)(b).

(5) See illustration in Rule 1680-06-03-.09, Appendix, for examples of abandoned devices.

Authority: T.C.A. §§ 54-21-102, 54-21-104, 54-21-105 and 54-21-~~442~~111. Administrative History: Original rule certified June 10, 1974. Repeal and new rule filed June 9, 1977; effective July 11, 1977. Repeal and new rule filed January 27, 1989; effective March 13, 1989. Amendment filed September 24, 2008; effective December 8, 2008.

1680-026-03-.08 VEGETATION CONTROL.

(1) ~~(1)~~—Definitions

- (a) For the purpose of T.C.A. § 54-21-~~449~~116, “generally visible” or “general visibility” is defined as capable of being visible to occupants of vehicles using the main traveled way for some of the distance between the point where such capacity occurs and the location perpendicular to the outdoor advertising device.
- (b) For the purpose of T.C.A. § 54-21-~~449~~116, “clearly visible” or “clear visibility” is defined as capable of advising of the message.

(2) ~~(2)~~—Administration

- (a) T.C.A. § 54-21-~~449~~116, is construed as being in contemplation of an increase in the amount or size of vegetation within those adjacent portions of the right-of-way

(Rule 1680-026-03-.02,

from which the face of an outdoor advertising device is capable of being visible to occupants of vehicles using the main traveled way existing on the date of erection of the outdoor advertising device, whereby such visibility becomes less than general visibility.

- (b) When applications are made for vegetation control permits, the area of general visibility on the date of erection will be reviewed to determine whether such an increase in the amount and size thereof has occurred since the date of erection to warrant the issuance of a permit to attain clear visibility for an adjacent area of up to 500 five hundred feet (500') within the area of general visibility. ~~Vegetation which that, on the date of erection of the outdoor advertising device, blocked the view of the outdoor advertising device on the date of erection, in whole or in any part, for a distance not to exceed five hundred yards (500 yds.), to occupants of vehicles using the main traveled ways, will~~ is not be eligible for removal under a vegetation control permit.
- (c) The vegetation control permit will authorize the permittee to remove, block cut, or trim vegetation located on the right-of-way adjacent to the outdoor advertising device, and replace the vegetation as directed, whenever the vegetation prevents clear visibility for a distance not to exceed five hundred yards (500 yds.) to occupants of vehicles using the main traveled ways of the controlled systems. The maximum area to be controlled shall not exceed five hundred feet (500').
- (d) Each vegetation control permit will be subject, at a minimum, to the following conditions:
1. Permittee shall obtain any permits or approvals required by any regulatory agency having jurisdiction under federal, state, or local law over any work to be performed on the highway right-of-way, including without limitation any permits required under water quality regulations.
 2. Normally, the permittee will be authorized to remove or control vegetation only through the use of mechanical methods; provided, however, that beginning on March 1, 2024, the Department may authorize the use of herbicides in specific circumstances, subject to strict conditions, including but not limited to the requirements that the use of any herbicide may be allowed only between March 1 and October 15 of each year and must be performed by a person who has a valid current pesticide applicator certification in the applicable service category for right-of-way pest control and has, or works under the direct supervision of a person who has, a valid current pest control operator license from the Tennessee Department of Agriculture.
 3. Permittee shall notify any utility company that may be affected by the work, as required by law, including without limitation compliance with the Underground Utility Damage Prevention Act, T.C.A. § 65-31-101, et seq, if applicable.
 4. Permittee shall comply with the provisions of the Manual on Uniform Traffic Control Devices, as adopted in TDOT Rule Chapter 1680-03-01, applicable to work being performed adjacent to highways.
 5. Parking on or working from the shoulder of the highway may be authorized only by special written permission from the Department. If authorization has been granted, a Shoulder Permit shall be attached to Vegetation Control Permit. Permittee's work forces must be present at all times any equipment is located on the shoulder.
 6. There shall be no overnight parking of equipment on highway right-of-way, and no equipment shall be parked on the shoulder of the highway when the permittee's work forces are not present.

(Rule 1680-026-03-.02,

7. If the highway right-of-way is access-controlled, the permittee shall not obtain access to the right-of-way across the access control boundary, and the permittee shall not cut, remove, or damage any access control fence; provided, however, that the applicant may request the Department to permit a break in access control to obtain access to the right-of-way. If the applicant requests a break in access control, the applicant shall include as a part of the vegetation control permit application a written proposal, with photographs, showing why the break in access control is needed, how the applicant will obtain access to the property outside the access control boundary, and the proposed extent and duration of the break in access control. The applicant will not be granted a break in access control for the purpose of obtaining access to the property outside the access control boundary. The permittee will be required to provide a temporary barrier to protect access control when not on the job site and will be required to restore the access control fence to the Department's specifications promptly upon completion of the vegetation control work. In the event that the permittee, or the permittee's agent or representative, does unauthorized damage to a fence or any other public property in the work area, the permittee shall immediately repair or replace the same at the permittee's expense.
 8. Any drainage tiles, culverts, or other drainage infrastructure must remain free and clear of cut brush, pulverized debris, or disturbed soil.
 9. If any work authorized under the permit results in the exposure of bare soil on the state highway right-of-way, the permittee shall install erosion prevention and sediment control measures, including at a minimum the spreading of grass seed and straw on the soil. A mixture of native grasses or native plant seeds is recommended to promote native habitat restoration. Sowing of noxious weed seeds is strictly prohibited.
 10. Trash and litter shall be picked up and removed from the highway right-of-way before mowing or bush-hogging; provided, however, that if the permittee discovers hazardous waste that cannot be taken to a landfill but instead requires specialized disposal (e.g., automobile batteries, tires, paint, medical waste, drug paraphernalia, etc.), the permittee shall promptly notify the Highway Beautification Office and cease any mowing or bush-hogging in the area where such waste is present.
 11. Upon completion of the work, all trimmed or cut vegetation, brush, limbs, or large debris must be removed from the highway right-of-way. Permittee may be allowed to use chippers and grinders to reduce trimmed and cut vegetation into pulverized material and left on the highway right-of-way. Large piles of pulverized material are to be spread across the ground in a thin layer. Any large limbs or debris remaining in whole or only partially ground up shall be removed from the highway right-of-way. All authorized vegetation removal shall be cut to ground level. Stumps above ground level must be removed by permittee.
 12. The Department reserves the right to add special permit conditions based on the particular circumstances existing at the vegetation control site. However, the Department will not add general permit terms and conditions applicable to all permits beyond the items identified in this subsection (e) without first publishing the proposed permit condition on the Highway Beautification Office website and allowing at least thirty (30) days for public comment.
- (e) Vegetation control permits issued pursuant to the Billboard Regulation and Control Act of 1972 shall be reinstated under the Outdoor Advertising Control Act of 2020. Alternatively, the owner of the device may apply for a new vegetation control permit, and the Department shall issue the permit in accordance with T.C.A. § 54-21-116 and this rule.

(Rule 1680-026-03-.02,

~~(3)~~ ~~(3)~~—Application for Vegetation Control Permit.

~~(a)~~ No person shall begin to cut, trim, or remove vegetation located on the right-of-way adjacent to outdoor advertising device without first obtaining a vegetation control permit from the Highway Beautification Office. Vegetation control permits issued pursuant to the Billboard Regulation and Control Act of 1972 shall be reinstated under the Outdoor Advertising Control Act of 2020. Alternatively, the owner of the device may apply for a new vegetation control permit, and the Department shall issue the permit in accordance with T.C.A. § 54-21-116 and this rule.

~~(b)~~ Before applying for a vegetation control permit, the applicant must verify that the issued tag for the permitted outdoor advertising device is posted on the device and visible from the main traveled way. Applications for devices without a visible tag will not be approved and the application fee will not be returned. A new replacement tag must be requested and posted on device before the applicant reapplies for a vegetation control permit.

~~(c)~~ The following procedure will be followed in order to ~~obtain~~apply a permit for a ~~for~~ vegetation control permit:

~~(a)1.~~ ~~R~~Request a vegetation control application form;

~~(b)2.~~ ~~R~~Return completed application to Highway Beautification Office, Department of Transportation, ~~Maintenance~~Right of Way Division, Suite 400, James K. Polk Building, 505 Deaderick Street, Nashville, TN- 3724937243-, and ~~E~~nclose a check or money order made payable to the Tennessee Department of Transportation in the amount of one hundred dollars (\$100.00) ~~dollars. This is for each sign face as~~ a non-refundable application fee; ~~and~~

~~(c)~~ ~~attach to application a copy of the current permit renewal form for the outdoor advertising around which vegetation control is requested.~~

~~(d)3.~~ ~~applicant must also a~~Attach the following additional information:

~~1.(i)~~ ~~a~~An 8"x10" or larger photograph showing the area in which vegetation control is proposed;

~~2.(ii)~~ ~~a~~A scale drawing showing vegetation proposed to be cut, trimmed, or removed, and labeling ~~Such vegetation should be labeled;~~

~~3.(iii)~~ ~~a~~A written proposal;

~~4.(iv)~~ ~~A~~A scale drawing showing the proposed replacement vegetation plan;

~~(v)~~ If applicable, a written proposal, with photographs, showing why a break in access control is needed, how the applicant will obtain access to the property outside the access control boundary, and the proposed extent and duration of the break in access control; and

~~(vi)~~ If applicable, a written proposal in support of a request to use a herbicide, with the reason for requesting the use, the proposed location for herbicide use, the herbicide application plan, the name and pesticide applicator certification number of the person who will apply the herbicide, and the name

(Rule 1680-026-03-.02,

and pest control license number of the person having supervisory responsibility for the herbicide application.

(d) The Highway Beautification Office shall use best efforts to process an application for a permit, in accordance with this rule, within no greater than thirty (30) days after a completed application is received, as follows:

1. If the application is incomplete or defective on its face, the Highway Beautification Office shall notify the applicant in writing no later than fifteen (15) days after receipt of the filed application of its incomplete or defective status and indicate the information or documentation that is needed to complete or correct the application.

2. If a decision to approve or deny the application cannot be made within thirty (30) days after receipt of the completed or corrected application, the Highway Beautification Office shall contact the applicant prior to the expiration of the thirty (30) days to provide an explanation of the reasons why additional time is needed to process the application.

(e) If the application for the vegetation control permit is approved, the Highway Beautification Office will send the applicant a written notice of approval, which shall identify the conditions applicable to the permit. The applicant shall notify the Highway Beautification Office of the date on which the applicant wishes the permit to be issued. If the vegetation control permit is granted, in addition, the applicant must provide the following:

1. A check or money order in the amount of one hundred fifty dollars (\$150.00) ~~dollars-per sign face~~ made payable to the Tennessee Department of Transportation- for supervision of the work; provided, however, that:

(i) One (1) vegetation control permit fee must be waived for those owners who voluntarily remove a nonconforming outdoor advertising device. If the nonconforming outdoor advertising device to be removed is not at least one hundred fifty square feet (150 sq. ft.) in size, two (2) nonconforming outdoor advertising devices must be removed to authorize waiver. The latter applies only when the outdoor advertising device around which control is to occur is larger than three hundred square feet (300 sq. ft.);

(ii) This waiver shall not be used as evidence in any future eminent domain proceeding relating to nonconforming outdoor advertising devices;

2. A surety bond- (on a form for this will be provided by the Department) in the amount of five thousand dollars (\$5,000) for each separate vegetation control permit; or in the alternative, the applicant may provide a running surety bond to cover multiple active vegetation control permits or vegetation maintenance permits at the applicable amount for each permit up to the maximum capacity of the bond; and

3. A certificate of insurance in the amount of not less than three hundred thousand dollars (~~\$400,000~~300,000) for each person injured and one million dollars (~~\$300,000~~1,000,000) for each ~~accident occurrence~~, plus \$50,000 total property damage for each accident, with such insurance to remain in full force and effect until work has been completed and approved by the Department.

(f) The permittee shall complete the authorized vegetation control within the time period specified in the permit, and in any event, the permittee shall complete the vegetation control within one (1) year after the date on which the application was

(Rule 1680-026-03-.02,

~~approved; otherwise, the application approval and permit is void. Furthermore, if a vegetation control permit is issued~~ the applicant shall abide by all conditions imposed by the ~~Tennessee Department of Transportation~~, as set forth on the face of the permit, or ~~suffer incur~~ permit revocation and other consequences of law. ~~(See illustrations in Rule 1680-06-03-.09, Appendix.)~~

- (g) ~~Vegetation control permits will be issued each year from October 1 through April 15. All work must be completed by April 15th. The Highway Beautification Office will accept vegetation control applications on September 1 of each year. The Highway Beautification Office will accept applications and issue vegetation control permits to allow vegetation control activities on a year-round basis; provided, however, if replacement vegetation is required, a vegetation control permit may be issued only between October 1 and April 15. If the Department authorizes the use of any herbicide as a method of vegetation control, the vegetation control permit may be issued only between March 1 and October 15.~~
- (4) Application for Vegetation Maintenance Permit
- (a) If a vegetation control permit has been issued for an outdoor advertising device, the holder of the permit may apply each subsequent year for a vegetation maintenance permit to provide annual maintenance at any one (1) location that is consistent with the original vegetation control permit.
- (b) Before applying for a vegetation maintenance permit, the applicant must verify that the issued tag for the permitted outdoor advertising device is posted on the device and visible from the main traveled way. Applications for devices without a visible tag will not be approved and the application fee will not be returned. A new replacement tag must be requested and posted on device before the applicant reapplies for a vegetation maintenance permit.
- (c) The following procedure shall be followed to apply for a vegetation maintenance permit:
1. Request a vegetation maintenance application form;
 2. Return completed application to Highway Beautification Office, Department of Transportation, Right of Way Division, Suite 400, James K. Polk Building, 505 Deaderick Street, Nashville, TN 37243., and enclose a check or money order made payable to the Tennessee Department of Transportation in the amount of fifty dollars (\$50.00) as a non-refundable fee; and
 3. Attach the following information:
 - (i) Copy of the original issued vegetation control permit or copy of last issued vegetation maintenance permit;
 - (ii) An 8"x10" or larger photograph showing the area in which vegetation control is proposed;
 - (iii) A scale drawing showing vegetation proposed to be cut, trimmed, or removed, and labeling such vegetation;
 - (iv) A written proposal;
 - (v) A scale drawing showing the proposed replacement vegetation plan;
 - (vi) If applicable, a written proposal, with photographs, showing why a break

(Rule 1680-026-03-.02,

in access control is needed, how the applicant will obtain access to the property outside the access control boundary, and the proposed extent and duration of the break in access control; and

(vii) If applicable, a written proposal in support of a request to use a herbicide, with the reason for requesting the use, the proposed location for herbicide use, the herbicide application plan, the name and pesticide applicator certification number of the person who will apply the herbicide, and the name and pest control license number of the person having supervisory responsibility for the herbicide application.

(d) If the application for a vegetation maintenance permit is approved, the Highway Beautification Office will send the applicant a written notice of approval, which shall identify the conditions applicable to the permit. Prior to issuance of the permit, the applicant must provide the following:

1. A surety bond (on a form provided by the Department) in the amount of two thousand five hundred dollars (\$2,500) for each separate vegetation maintenance permit; or in the alternative, the applicant may provide a running surety bond to cover multiple active vegetation control permits or vegetation maintenance permits at the applicable amount for each permit up to the maximum capacity of the bond; and
2. A certificate of insurance in the amount of not less than three hundred thousand dollars (\$300,000) for each person injured and one million dollars (\$1,000,000) for each occurrence, with such insurance to remain in full force and effect until work has been completed and approved by the Department.

(e) Furthermore, if a vegetation maintenance permit is issued, the applicant shall abide by all conditions imposed by the Department, as set forth on the face of the permit, or incur permit revocation and other consequences of law. The vegetation maintenance permit will be subject, at a minimum, to the following conditions:

1. Permittee shall obtain any permits or approvals required by any regulatory agency having jurisdiction under federal, state, or local law over any work to be performed on the highway right-of-way, including without limitation any permits required under water quality regulations.
2. Normally, the permittee will be authorized to remove or control vegetation only through the use of mechanical methods; provided, however, that beginning on March 1, 2024, the Department may authorize the use of herbicides in specific circumstances, subject to strict conditions, including but not limited to the requirements that the use of any herbicide may be allowed only between March 1 and October 15 of each year and must be performed by a person who has a valid current pesticide applicator certification in the applicable service category for right-of-way pest control and has, or works under the direct supervision of a person who has, a valid current pest control operator license from the Tennessee Department of Agriculture.
3. Permittee shall notify any utility company that may be affected by the work, as required by law, including without limitation compliance with the Underground Utility Damage Prevention Act, T.C.A. § 65-31-101, et seq. if applicable.
4. Permittee shall comply with the provisions of the Manual on Uniform Traffic Control Devices, as adopted in TDOT Rule Chapter 1680-03-01, applicable to work being performed adjacent to highways.

(Rule 1680-026-03-.02,

5. Parking on or working from the shoulder of the highway may be authorized only by special written permission from the Department. If authorization has been granted, a Shoulder Permit shall be attached to Vegetation Control Permit. Permittee's work forces must be present at all times any equipment is located on the shoulder.
6. There shall be no overnight parking of equipment on highway right-of-way, and no equipment shall be parked on the shoulder of the highway when the permittee's work forces are not present.
7. If the highway right-of-way is access-controlled, the permittee shall not obtain access to the right-of-way across the access control boundary, and the permittee shall not cut or remove any access control fence; provided, however, that the applicant may request the Department to permit a break in access control to obtain access to the right-of-way. If the applicant requests a break in access control, the applicant shall include as a part of the vegetation maintenance permit application a written proposal, with photographs, showing why the break in access control is needed, how the applicant will obtain access to the property outside the access control fence, and proposed extent and duration of the break in access control. The applicant will not be granted a break in access control for the purpose of obtaining access to the property outside the access control fence. The permittee will be required to provide a temporary barrier to protect access control when not on the job site and will be required to restore the access control fence to the Department's specifications promptly upon completion of the vegetation maintenance work. In the event that the permittee, or the permittee's agent or representative, does unauthorized damage a fence or any other public property in the work area, the permittee shall repair or replace the same at the permittee's expense.
8. Any drainage tiles, culverts, or other drainage infrastructure must remain free and clear of cut brush, pulverized debris, or disturbed soil.
9. If any work authorized under the permit results in the exposure of bare soil on the state highway right-of-way, the permittee shall install erosion prevention and sediment control measures, including at a minimum the spreading of grass seed and straw on the soil. A mixture of native grasses or native plant seeds is recommended to promote native habitat restoration. Sowing of noxious weed seeds is strictly prohibited.
10. Trash and litter shall be picked up and removed from the highway right-of-way before mowing or bush-hogging; provided, however, if the permittee discovers hazardous waste that cannot be taken to a landfill but instead requires specialized disposal (e.g., automobile batteries, tires, paint, medical waste, drug paraphernalia, etc.), the permittee shall promptly notify the Highway Beautification Office and cease any mowing or bush-hogging in the area where such waste is present.
11. Upon completion of the work, all trimmed or cut vegetation, brush, limbs, or large debris must be removed from the highway right-of-way. Permittee may be allowed to use chippers and grinders to reduce trimmed and cut vegetation into pulverized material and left on the highway right-of-way. Large piles of pulverized material are to be spread across the ground in a thin layer. Any large limbs or debris remaining in whole or only partially ground up shall be removed from the highway right-of-way. All authorized vegetation removal shall be cut to ground level. Stumps above ground level must be removed by permittee.
12. The Department reserves the right to add special permit conditions based on the particular circumstances existing at the vegetation control site. However, the Department will not add general permit terms and conditions applicable to all permits beyond the items identified in this subsection (e) without first publishing the

(Rule 1680-026-03-.02,

proposed permit condition on the Highway Beautification Office website and allowing at least thirty (30) days for public comment.

(f) The Highway Beautification Office will accept applications and issue ~~Vegetation control maintenance permits will be issued on a year-round basis year-round and between April 15 and October 1 provided no replacement vegetation is required.~~ If the Department authorizes the use of any herbicide as a method of vegetation control, the vegetation maintenance permit will only be issued between March 1 and October 15.

(5) Enforcement of Vegetation Control

(a) The Commissioner may revoke, suspend, or modify any vegetation control permit or vegetation maintenance permit for cause, including violation of any terms or conditions of the permit.

(b) If, before obtaining an outdoor advertising device permit and a vegetation control permit, vegetation located on state highway right-of-way is removed, cut, or trimmed, and application is subsequently made for an outdoor advertising permit, then the Commissioner may deny the permit.

(c) If, before applying for a vegetation control permit, vegetation located on state highway right-of-way is removed, cut, or trimmed in the vicinity of an outdoor advertising device, which action was reasonably calculated to afford greater visibility of the outdoor advertising device, then the Commissioner may revoke the outdoor advertising device permit or permits for the affected outdoor advertising devices.

(d) Prior to invoking this section, the Commissioner or the Commissioner's designee shall advise the affected outdoor advertising device permit applicant or holder, whichever is appropriate, that a preliminary determination of illegality has been made. The party so advised must be given the opportunity to request a hearing to be conducted pursuant to contested case provisions of the Uniform Administrative Procedures Act, compiled in Tennessee Code Annotated, Title 4, Chapter 5, before the Commissioner may make a final determination of illegality.

Authority: T.C.A. §§ ~~54-21-23111, 54-21-116~~, and ~~U.S.C. §13154-21-117~~. Administrative History: Original rule certified June 10, 1974. Repeal and new rule filed June 9, 1977; effective July 11, 1977. Repeal and new rule filed January 27, 1989; effective March 13, 1989.

1680-026-03-.09 -APPENDIX.

(1) Agreements between the Tennessee Department of Transportation and the United States Department of Transportation, Federal Highway Administration.(a) Original Agreement (November 11, 1971)

A G R E E M E N T

FOR CARRYING OUT NATIONAL POLICY RELATIVE TO CONTROL OF OUTDOOR ADVERTISING IN AREAS ADJACENT TO THE NATIONAL SYSTEM OF INTER-STATE AND DEFENSE HIGHWAYS AND THE FEDERAL-AID PRIMARY SYSTEM.

* * *

THIS AGREEMENT made and entered into this 11th day of November, 1971, by and between the United States of America represented by the Secretary of Transportation, acting by and through the FEDERAL HIGHWAY ADMINISTRATOR, hereinafter referred to as the "ADMINISTRATOR", and the State of Tennessee, represented by the DEPARTMENT OF HIGHWAYS acting by and through its Commissioner, hereinafter referred to as the "STATE".

W I T N E S S E T H:

WHEREAS, Congress has declared that Outdoor Advertising in areas adjacent to the Interstate and Federal-aid Primary Systems should be controlled in order to protect the public investment in such highways, to promote the safety and recreational value of public travel and to preserve natural beauty; and

WHEREAS, Section 131(d) of Title 23, United States Code, authorizes the Secretary of Transportation to enter into agreements with the several States to determine the size, lighting and spacing of signs, displays, and devices, consistent with customary use, which may be erected and maintained within 660 feet of the nearest edge of the right-of-way within areas adjacent to the Interstate and Federal-aid Primary Systems which are zoned industrial or com-

mercial under authority of State law or in unzoned commercial or industrial areas, as may be determined by agreements between the several States and the Secretary of Transportation; and

WHEREAS, the purpose of said agreements is to promote the reasonable, orderly and effective display of outdoor advertising while remaining consistent with the National policy to protect the public investment in the Interstate and Federal-aid primary highways, to promote the safety and recreational value of public travel and to preserve natural beauty; and

WHEREAS, the STATE OF TENNESSEE desires to implement and carry out the provisions of Section 131 of Title 23, United States Code, and said National policy.

NOW, THEREFORE, the parties hereto do mutually agree as follows:

I. Definitions

- A. The term "ACT" means Section 131 of Title 23, United States Code (1965) commonly referred to as Title I of the Highway Beautification Act of 1965.
- B. Commercial or industrial activities for purposes of unzoned industrial and commercial areas mean those activities generally recognized as commercial or industrial by zoning authorities in this State, except that none of the following activities shall be considered commercial or industrial activities:

1. Outdoor advertising structures.
 2. Agricultural, forestry, ranching, grazing, farming and related activities, including, but not limited to, wayside fresh produce stands.
 3. Transient or temporary activities.
 4. Activities not visible from the main traveled way.
 5. Activities more than 660 feet from the nearest edge of the right-of-way.
 6. Activities conducted in a building principally used as a residence.
 7. Railroad tracks and minor sidings.
- C. Zoned commercial or industrial areas mean those areas which are reserved for business, commerce, or trade pursuant to State or local zoning regulations.
- D. Unzoned commercial or industrial areas mean those areas on which there is located one or more permanent structures devoted to a commercial or an industrial activity or on which a commercial or an industrial activity is actually conducted, whether or not a permanent structure is located thereon, and the area along the highway extending outward 600 feet from and beyond the edge of such activity in each direction and a corresponding zone directly across a primary highway which is not also a limited access highway when the same is not a public park, public playground, public recreational area, public forest, wildlife, or waterfowl refuge, historic

site, scenic area, cemetery, or primarily residential in character. The unzoned areas shall not include land across the highway from a commercial or an industrial activity when said highway is an Interstate or a controlled access primary highway.

All measurements shall be from the outer edges of the regularly used buildings, parking lots, storage, processing or landscaped areas of the commercial or industrial activity, not from the property lines of the activity, and shall be along or parallel to the edge of the pavement of the highway.

- E. Interstate System means that portion of the National System of Interstate and Defense Highways located within this STATE, as officially designated, or as may hereafter be so designated, by the Commissioner of Highways, and approved by the Secretary of Transportation, pursuant to the provisions of Title 23, United States Code.
- F. Primary System means that portion of connected main highways, as officially designated, or as may hereafter be so designated, by the Commissioner of Highways, and approved by the Secretary of Transportation, pursuant to the provisions of Title 23, United States Code.
- G. Traveled way means the portion of a roadway for the movement of vehicles, exclusive of shoulders.
- H. Main-traveled way means the traveled way of a highway on which through traffic is carried.

In the case of a divided highway, the traveled way of each of the separated roadways for traffic in opposite directions is a main-traveled way. It does not include such facilities as frontage roads, turning roadways, or parking areas.

- I. Outdoor advertising or sign means any outdoor sign, display, device, notice, bulletin, figure, painting, drawing, message, placard, poster, billboard or other thing which is used to advertise or inform, any part of the advertising or informative contents of which is visible from any place on the main-traveled way of any portion of any Interstate or primary highway.
- J. Erect means to construct, build, raise, assemble, place, affix, attach, create, paint, draw, or in any other way bring into being or establish.

II. Scope of Agreement

This Agreement shall apply to all zoned and unzoned commercial and industrial areas within 660 feet of the nearest edge of the right-of-way of the Interstate and Federal-aid Primary Systems, in which outdoor advertising signs, displays, and devices may be visible from the main-traveled way of either or both of said systems.

III. State Control

The STATE hereby agrees that, in all areas within the scope of this Agreement, the STATE shall effectively control, or cause to be controlled, the erection and maintenance of outdoor advertising signs, displays, and devices erected subsequent to the effective date of this Agreement, other than those advertising the sale or lease of the property on which they are located, or activities conducted thereon, in accordance with the following:

A. In zoned commercial and industrial areas, the STATE may notify the Secretary as notice of effective control that there has been established within such areas comprehensive zoning which regulates the size, lighting, and spacing of outdoor advertising signs consistent with the intent of the Act and with customary use.

B. In all other zoned and unzoned commercial and industrial areas, within the scope of this Agreement, the criteria set forth below shall apply.

Size of Signs

1. The maximum area for any one sign shall be 1200 square feet, however, with a maximum height of 30 feet or maximum length of 60 feet, inclusive of any border and trim but excluding ornamental base or apron supports and other structural members; provided further, however, that in counties having a population greater than 250,000, the STATE may establish standards for maximum size greater than 1200 square feet in area, provided that any such standards shall be in accord with customary use of off-premise outdoor advertising within the area in which

said standards will apply. In no instance, however, shall these standards exceed 3000 square feet, inclusive of any border and trim, and exclusive of ornamental base or apron supports and other standard members.

2. The area shall be measured by the smallest square rectangle, triangle, circle or combination thereof which will encompass the entire sign.
3. A sign structure may contain one or two signs per facing and may be placed doubled-faced, back to back or V-type, but the total area of any facing may not exceed 1200 square feet.

Spacing of Signs

1. Interstate Highways and Controlled Access Highways on the Federal-aid Primary System
 - (a) No two structures shall be spaced less than 500 feet apart on the same side of the highway, provided, however, that such signs may be located within 500 feet of another sign when the signs are separated by buildings or other obstructions so that only one sign located adjacent to or within the 500 feet zone is visible from the highway at any one time.
 - (b) Outside incorporated municipalities no structure may be located adjacent to, or within 500 feet of an interchange, or intersection at grade, measured along the Interstate or controlled access highways on the primary system from the nearest point of the beginning or ending of pavement widening at the exit from or entrance to the main-traveled way.
2. Non-Controlled Access Primary Highways
 - (a) Outside of the corporate limits of a municipality no two structures shall be spaced less than 300 feet apart on the same side of the highway.
 - (b) Within the corporate limits of a municipality no two structures shall be spaced less than 100 feet apart on the same side of the highway.
 - (c) Provided, however, with respect to a and b above, that structures may be spaced closer to others when they are separated by buildings or other obstructions so that only one is visible within the otherwise applicable spacing requirement at any one time.

3. Explanatory Notes

(a) Official and "on premise" signs, as defined in Section 131(c) of Title 23, United States Code, shall not be counted nor shall measurements be made from them for purposes of determining compliance with spacing requirements.

(b) The minimum distance between signs shall be measured along the nearest edge of the pavement between points directly opposite the signs along each side of the highway.

Lighting of Signs

Signs may be illuminated, subject to the following restrictions:

1. Signs which contain, include, or are illuminated by any flashing, intermittent, or moving light or lights are prohibited, except those giving public service information such as time, date, temperature, weather or similar information.
2. Signs which are not effectively shielded as to prevent beams or rays of light from being directed at any portion of the traveled ways of the Interstate or Federal-aid primary highway and which are of such intensity or brilliance as to cause glare or to impair the vision of the driver of any motor vehicle, or which otherwise interfere with any driver's operation of a motor vehicle are prohibited.
3. No sign shall be so illuminated that it interferes with the effectiveness of, or obscures an official traffic sign, device, or signal.

C. The STATE and local governments shall have full authority under any present or future zoning laws to zone areas for commercial or industrial purposes and the action of the STATE and local governments in this regard will be accepted for the purposes of this Agreement. At any time that a local government adopts comprehensive zoning which includes the regulation of outdoor advertising, the STATE may so

certify to the ADMINISTRATOR and control of outdoor advertising in commercial or industrial zones will transfer as provided in subsection A of this section.

IV. Interpretation

The provisions contained herein shall constitute the minimum acceptable standards for effective control of signs, displays, and devices within the scope of this Agreement.

Nothing contained herein shall be construed to abrogate or prohibit the STATE or any local government from exercising a greater degree of control of outdoor advertising than that required or contemplated by the Act or from adopting standards which are more restrictive in controlling outdoor advertising than the provisions of this Agreement.

In the event the provisions of the Highway Beautification Act of 1965 are amended by subsequent action of Congress, the parties reserve the right to re-negotiate this Agreement or to modify it to conform with any amendment.

V. Effective Date

This Agreement shall become effective upon the passage of an Act by the General Assembly authorizing the same.

IN WITNESS WHEREOF, the parties hereto have caused this Agreement to be executed by their respective duly authorized officials on the day and date first above written.

STATE OF TENNESSEE
DEPARTMENT OF HIGHWAYS

By: 
COMMISSIONER

UNITED STATES OF AMERICA

By: 
FEDERAL HIGHWAY ADMINISTRATOR

(b) Supplemental Agreement (October 16, 1984)

SUPPLEMENTAL AGREEMENT

RELATIVE TO

AGREEMENT FOR CARRYING OUT NATIONAL POLICY RELATIVE TO CONTROL OF OUTDOOR ADVERTISING IN AREAS ADJACENT TO THE NATIONAL SYSTEM OF INTERSTATE AND DEFENSE HIGHWAYS AND THE FEDERAL-AID PRIMARY SYSTEM.

This agreement made and entered into this 16 day of OCT, 1984 by and between the United States of America, represented by the Secretary of Transportation, acting by and through the Federal Highway Administrator, hereinafter referred to as the "Administrator" and the State of Tennessee, represented by the Department of Transportation, acting by and through its Commissioner, hereinafter referred to as the "State".

WITNESSETH:

WHEREAS, on or about November 11, 1971 the parties hereto entered into agreement, hereinafter referred to as the "Original Agreement", to promote the reasonable, orderly and effective display of outdoor advertising while remaining consistent with the National policy to protect the public investment in the Interstate and Federal-aid Primary Systems, to promote the safety and recreational value of public travel and to preserve natural beauty; and

WHEREAS, the General Assembly of the State of Tennessee authorized the Commissioner of Transportation to enter into the Original Agreement; and

WHEREAS, the General Assembly provided that any modification of the Original Agreement should become effective only upon passage of an Act authorizing same by the General Assembly; and

WHEREAS, the General Assembly has authorized certain amendments to the Original Agreement, said amendments being set forth in Chapter 133, Section 4 of the Public Acts of 1983; and

WHEREAS, the General Assembly authorized the Commissioner of Transportation to execute a modification of the Original Agreement to reflect said amendments.

NOW, THEREFORE, the parties hereto agree that the Original Agreement shall be amended as follows:

SECTION 1. Provision I. (Definitions) Part D. (Unzoned Commercial or Industrial Areas) of the Original Agreement is amended by deleting the following language and punctuation:

"Unzoned commercial or industrial areas means those areas on which there is located one or more permanent structures devoted to a commercial or an industrial activity or on which a commercial or an industrial activity is actually conducted, whether or not a permanent structure is located thereon,"

and by substituting instead the following language and punctuation:

"Unzoned commercial or industrial areas means those areas on which there are located one or more permanent structures within which a commercial or an industrial business is actively conducted, and which are equipped with all customary utilities facilities and open to the public regularly or regularly used by employees of the business as their principal work station, or which, due to the nature of the business, are equipped, staffed and accessible to the public as is customary,".

SECTION 2. Provision III. (State Control) Part B. (Size of Signs), 1. of the Original Agreement is amended by deleting the provision in its entirety and by substituting instead the following:

"The maximum area for any one sign shall be seven hundred seventy-five square feet, including any border and trim but excluding ornamental base or apron supports and other structural members; provided further however that in counties having a population greater than two hundred fifty thousand, the maximum size of any one sign shall be twelve hundred square feet including any border and trim, but excluding ornamental base or apron supports and other structural members."

SECTION 3. Provision III. (State Control) Part B. (Size of Signs), 3. of the Original Agreement is amended by deleting the language:

"but the total area of any facing may not exceed 1200 square feet",

and by substituting instead the following:

"but the total area of any facing may not exceed seven hundred seventy-five square feet, unless the sign structure is located in a county having a population greater than two hundred fifty thousand, in which case the total area of any facing may not exceed twelve hundred square feet inclusive of any border and trim, but excluding ornamental base or apron supports and other structural members."

SECTION 4. Provision III. (State Control) Part B. (Spacing of Signs)

1.(a) of the Original Agreement is amended by deleting from lines 1, 2, 3, 4 and 6 the symbol and word "500 feet" and by substituting instead the symbol and word "1,000 feet".

SECTION 5. Provision III. (State Control) Part B. (Spacing of Signs)

1.(b) of the Original Agreement is amended by deleting from line 2 the symbol and word "500 feet" and substituting instead the symbol and word "1,000 feet".

SECTION 6. Provision III. (State Control) Part B. (Spacing of Signs)

2.(a) of the Original Agreement is amended by deleting from line 2 the symbol and word "300 feet" and by substituting instead the symbol and word "500 feet".

SECTION 7. All other provisions of the Original Agreement shall remain in full force and effect.

SECTION 8. This agreement shall become effective upon execution.

IN WITNESS WHEREOF, the parties hereto have caused this agreement to be executed by their respective duly authorized officials on the day and date first above written.

STATE OF TENNESSEE
DEPARTMENT OF TRANSPORTATION

BY: Robert E. Farris
Robert E. Farris
Commissioner

UNITED STATES OF AMERICA

BY: Ray Burchard
Federal Highway Administrator

(2) Brightness Standards for Changeable Message Signs with a Digital Display

T.C.A. § 54-21-119(h) establishes the brightness standards for changeable message signs with a digital display, as follows:

- (a) All changeable message signs installed on or after July 1, 2014, must come equipped with a light-sensing device that automatically adjusts the brightness in direct correlation with ambient light conditions.
- (b) The brightness of light emitted from a changeable message sign must not exceed 0.3 foot candles over ambient light levels measured at a distance of one hundred fifty feet (150') for those sign faces less than or equal to three hundred square feet (300 sq. ft.), measured at a distance of two hundred feet (200') for those sign faces greater than three hundred square feet (300 sq. ft.) but less than or equal to three hundred eighty-five square feet (385 sq. ft.), measured at a distance of two hundred fifty feet (250') for those sign faces greater than three hundred eighty-five square feet (385 sq. ft.) and less than or equal to six hundred eighty square feet (680 sq. ft.), measured at a distance of three hundred fifty feet (350') for those sign faces greater than six hundred eighty square feet (680 sq. ft.), or subject to the measuring criteria in the applicable table set forth in subdivision (h)(4).
- (c) Any measurements required pursuant to this subsection (h) must be taken from a point within the highway right-of-way at a safe distance from the edge of the traveled way, at a height above the roadway that approximates a motorist's line of sight, and as close to perpendicular to the face of the changeable message sign as practical. If perpendicular measurement is not practical, valid measurements may be taken at an angle up to forty-five (45) degrees from the center point of the sign face. If measurement shows a level above that prescribed in subdivision (h)(4), the exact calculations must be provided to the sign permit holder.
- (d) In the event it is found not to be practical to measure a changeable message sign at the distances prescribed in subdivision (h)(2), a measurer may opt to measure the sign at any of the alternative measuring distances described in the applicable table set forth in this subdivision (h)(4). In the event the sign measurer chooses to measure the sign using an alternative measuring distance, the prescribed foot candle level above ambient light must not exceed the prescribed level, to be determined based on the alternative measuring distances set forth in the tables in subdivisions (h)(4)(A), (B), (C), and (D), as applicable.

For any measuring distance between the alternative measuring distances set forth in the following tables, the prescribed foot candle level above ambient light must not exceed the interpolated level derived from the following formula:

$$I_2 = (D_2 - D_1) / (D_1 - D_2) \times I_1$$

Where I1 = the prescribed foot candle level above ambient light for the measuring distance listed in the tables, I2 = the derived foot candle level above ambient light for the desired measuring distance, D1 = the desired measuring distance in feet, and D2 = the alternative measuring distance in feet listed in the tables, as follows:

1. For changeable message signs less than or equal to three hundred square feet (300 sq. ft.):

<u>Alternative Measuring Distance:</u>	<u>Prescribed Foot Candle Level:</u>
<u>100</u>	<u>0.68</u>
<u>125</u>	<u>0.43</u>
<u>150</u>	<u>0.3</u>
<u>200</u>	<u>0.17</u>
<u>250</u>	<u>0.11</u>
<u>275</u>	<u>0.09</u>
<u>300</u>	<u>0.08</u>
<u>325</u>	<u>0.06</u>
<u>350</u>	<u>0.06</u>
<u>400</u>	<u>0.04</u>

3. For changeable message signs greater than three hundred square feet (300 sq. ft.) but less than or equal to three hundred eighty-five square feet (385 sq. ft.):

<u>Alternative Measuring Distance:</u>	<u>Prescribed Foot Candle Level:</u>
<u>100</u>	<u>1.2</u>
<u>125</u>	<u>0.77</u>
<u>150</u>	<u>0.53</u>
<u>200</u>	<u>0.3</u>
<u>250</u>	<u>0.19</u>
<u>275</u>	<u>0.16</u>
<u>300</u>	<u>0.13</u>
<u>325</u>	<u>0.11</u>
<u>350</u>	<u>0.1</u>
<u>400</u>	<u>0.08</u>

3. For changeable message signs greater than three hundred eighty-five square feet (385 sq. ft.) but less than or equal to six hundred eighty square feet (680 sq. ft.):

<u>Alternative Measuring Distance:</u>	<u>Prescribed Foot Candle Level:</u>
<u>100</u>	<u>1.88</u>
<u>125</u>	<u>1.2</u>
<u>150</u>	<u>0.83</u>
<u>200</u>	<u>0.47</u>
<u>250</u>	<u>0.3</u>
<u>275</u>	<u>0.25</u>
<u>300</u>	<u>0.21</u>
<u>325</u>	<u>0.18</u>
<u>350</u>	<u>0.15</u>
<u>400</u>	<u>0.12</u>

4. For changeable message signs greater than six hundred eighty square feet (680 sq. ft.):

<u>Alternative Measuring Distance:</u>	<u>Prescribed Foot Candle Level:</u>
<u>100</u>	<u>3.675</u>
<u>125</u>	<u>2.35</u>
<u>150</u>	<u>1.63</u>
<u>200</u>	<u>0.92</u>
<u>250</u>	<u>0.59</u>
<u>275</u>	<u>0.49</u>

CONTROL OF OUTDOOR ADVERTISING

CHAPTER 1680-06-03

<u>300</u>	<u>0.41</u>
<u>325</u>	<u>0.35</u>
<u>350</u>	<u>0.3</u>
<u>400</u>	<u>0.23</u>
<u>425</u>	<u>0.2</u>
<u>450</u>	<u>0.18</u>
<u>500</u>	<u>0.15</u>

(e) The brightness standards established in T.C.A. § 54-21-119(h) apply to all changeable message signs located in this state operated pursuant to a permit issued by the Commissioner.

(3) Illustrations

(a) Abandoned Devices

CONTROL OF OUTDOOR ADVERTISING

ABANDONED DEVICES

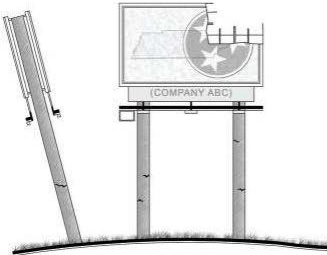

(1) Damaged
(Not Destroyed / Not Abandoned)

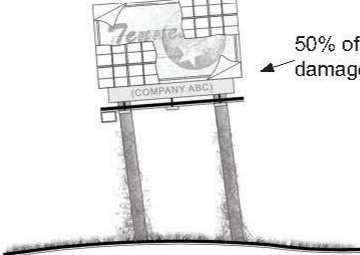

50% of face damaged

(2) Abandoned

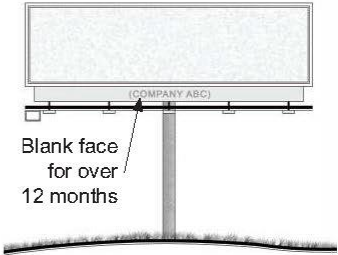

Blank face for over 12 months

(3) Abandoned



(4) Abandoned
(No structure)



(5) Not Abandoned

"Abandoned Outdoor Advertising Device" means any regulated outdoor advertising device which for a twelve (12) month period falls into one or more of the following classifications:

- (1) A device in the case of a wooden sign structure means that sixty percent (60%) or more of the upright supports of the sign structure are physically damaged such that normal repair practices would call for replacement of the broken supports.
- (2) A device whose sign face is damaged fifty percent (50%) or more.
- (3) A device that displays no message and blank display.
- (4) A device that has been removed from its permitted locations for more than twelve (12) months.
- (5) Not abandoned, device with display.

Not to Scale

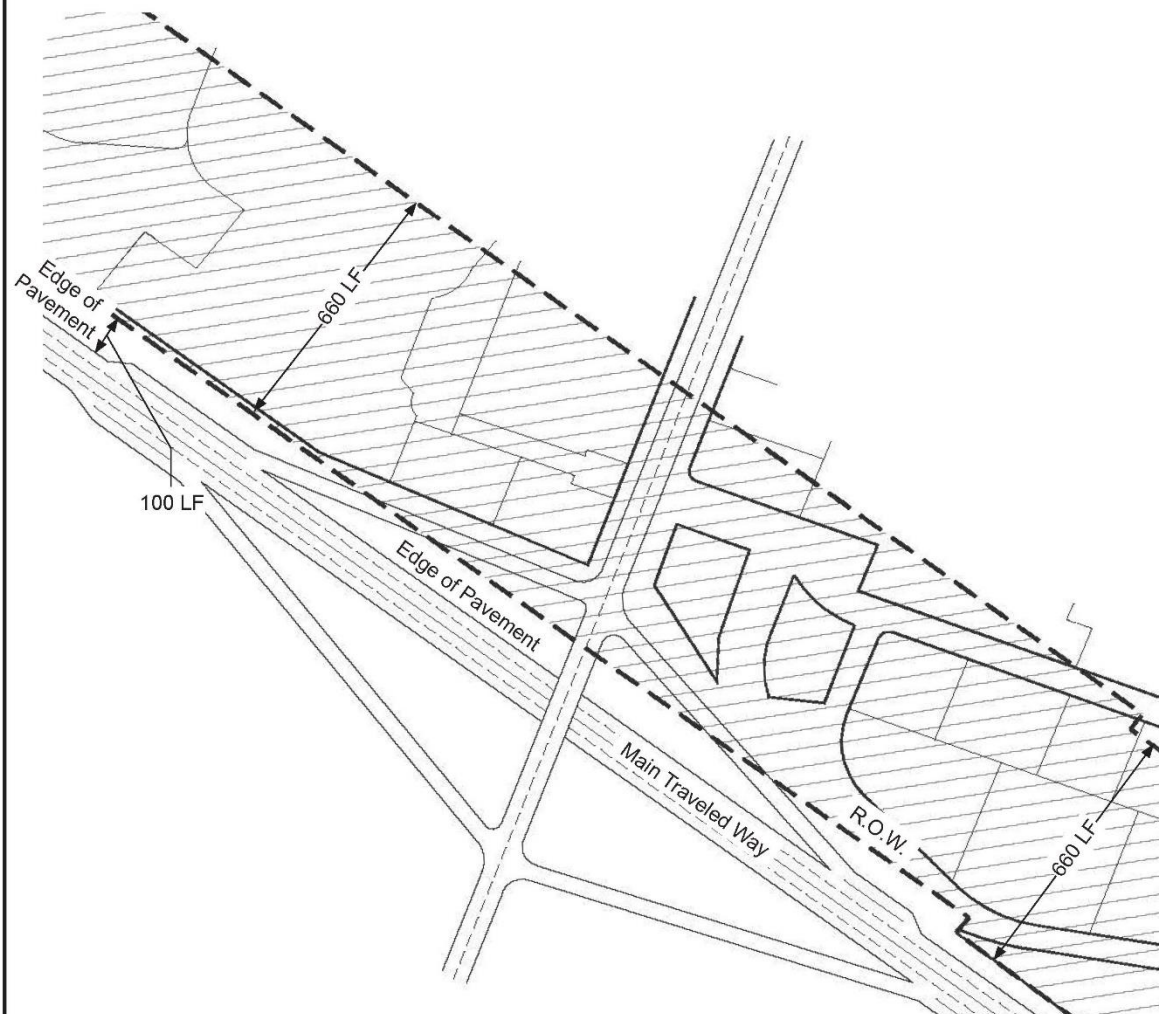
(b) Measurement of Adjacent Area at Interchanges**MEASUREMENT OF THE ADJACENT AREA****(a) Measurement of the adjacent area.**

1. In general, the measurement of the adjacent area shall begin at the nearest edge of the highway right-of-way property line and continue outward six hundred and sixty feet (660'); provided, however, that:
2. Where the highway right-of-way width extends outward more than one hundred feet (100') from the main traveled way of an interstate or other controlled access highway at an interchange with another highway that is not a controlled access highway, the measurement of the adjacent area beyond the interchange will begin at a line that is one hundred feet (100') outward from, and parallel to, the outside edge line of the through lanes on the main traveled way, excluding shoulders, exit ramps, entrance ramps, and acceleration or deceleration lanes.

Not to Scale

(c) Destroyed Non-Conforming Outdoor Advertising Device

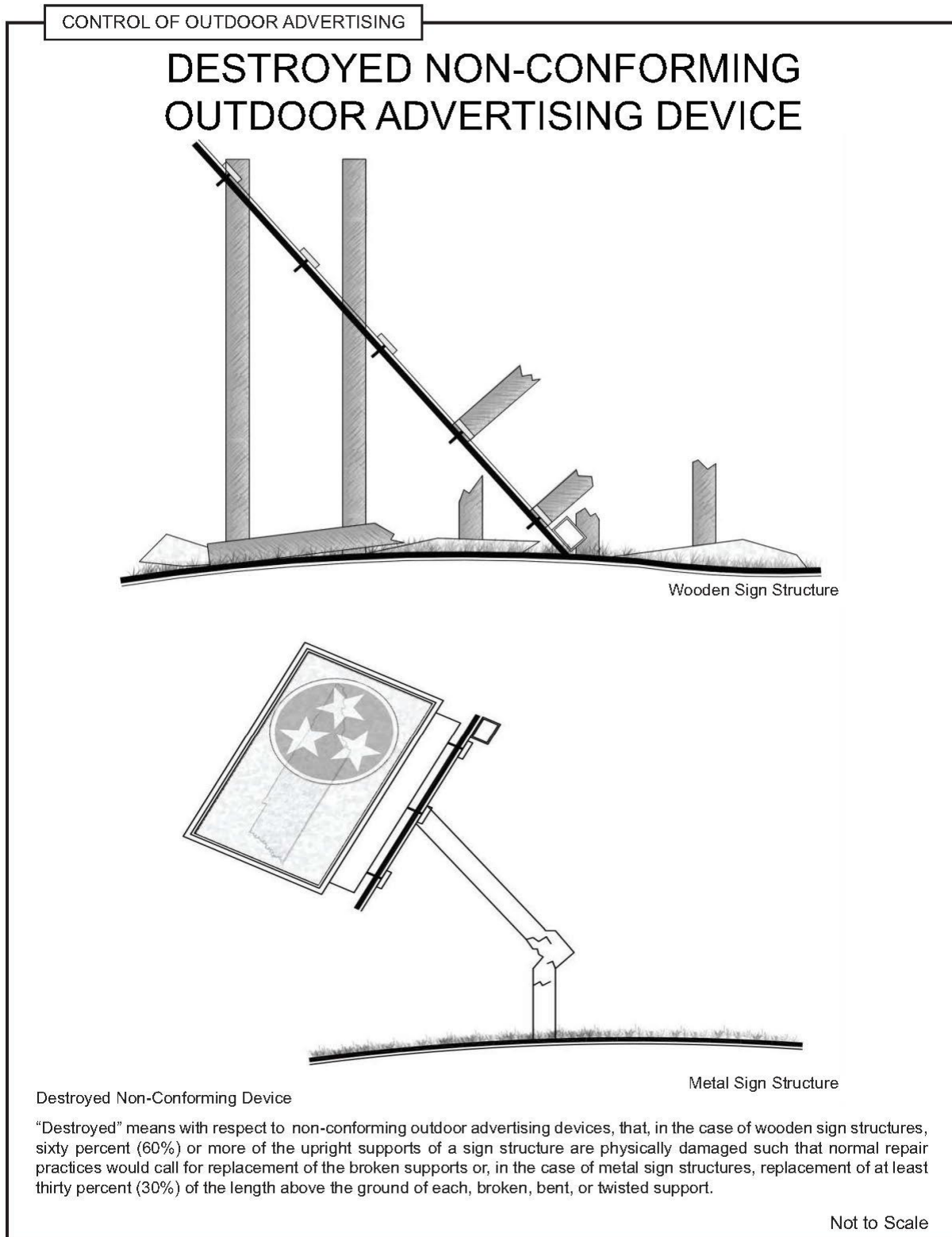

(d) Device Types: Double-Faced

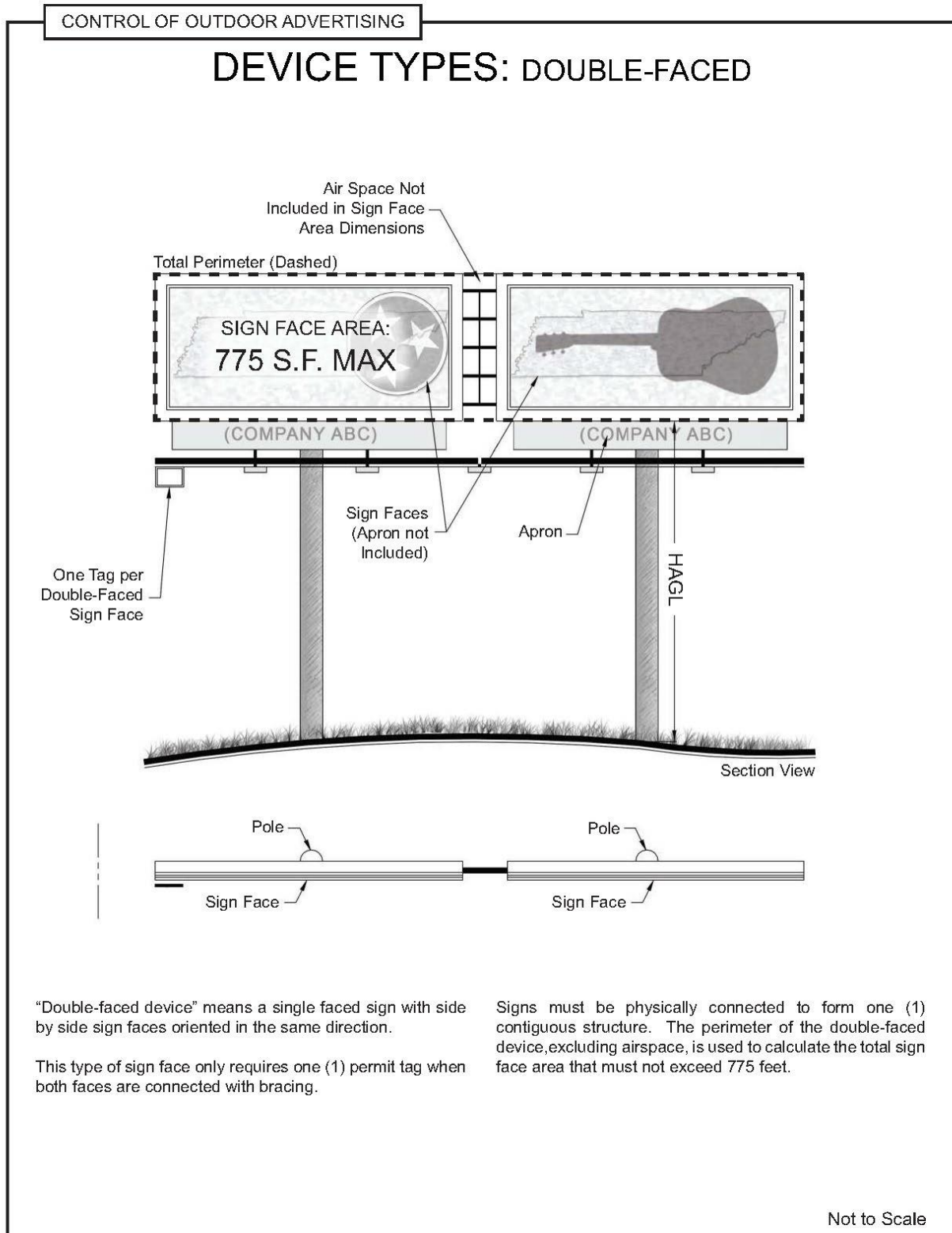

(e) Device Types: Back-To-Back

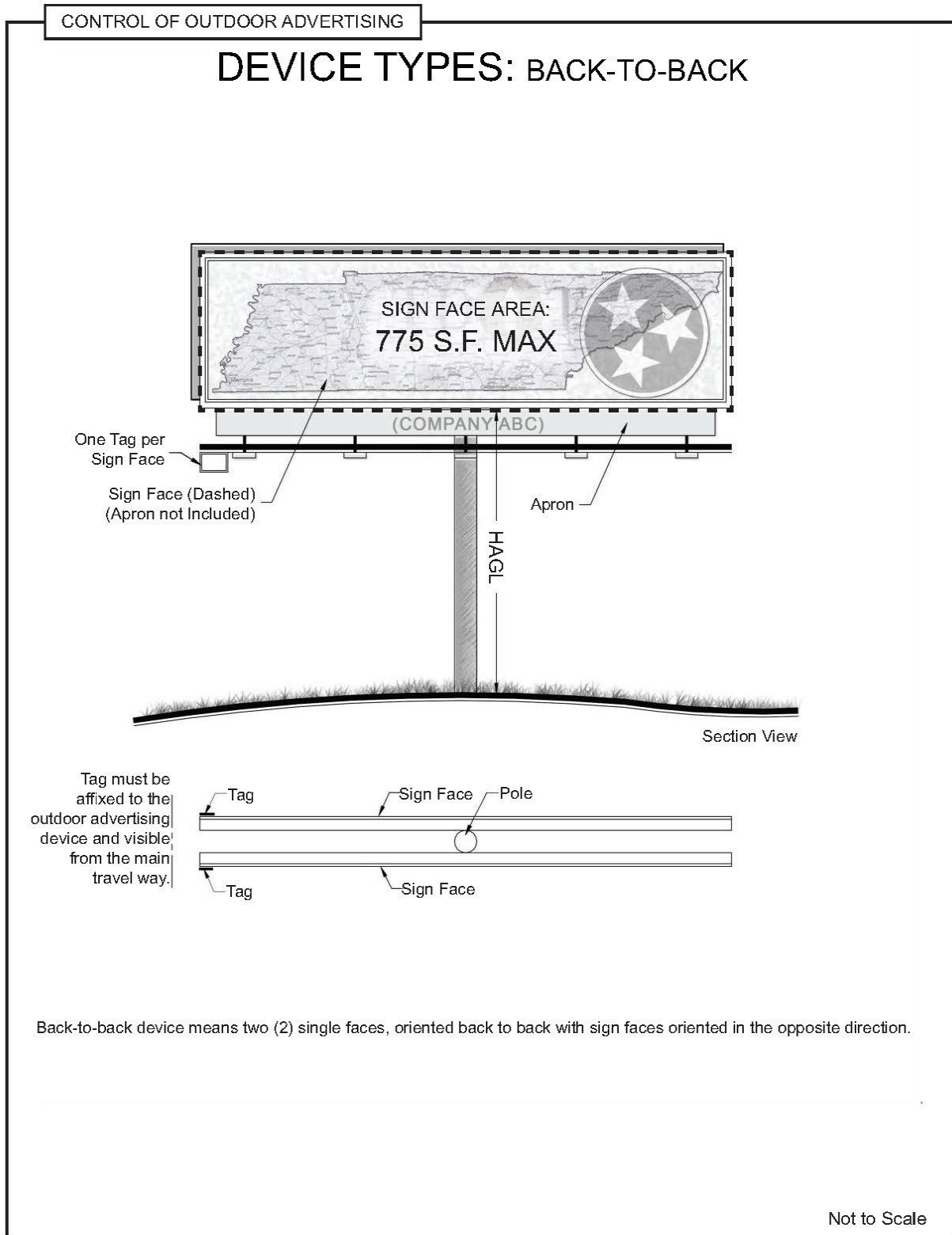

(f) Device Types: V-Type

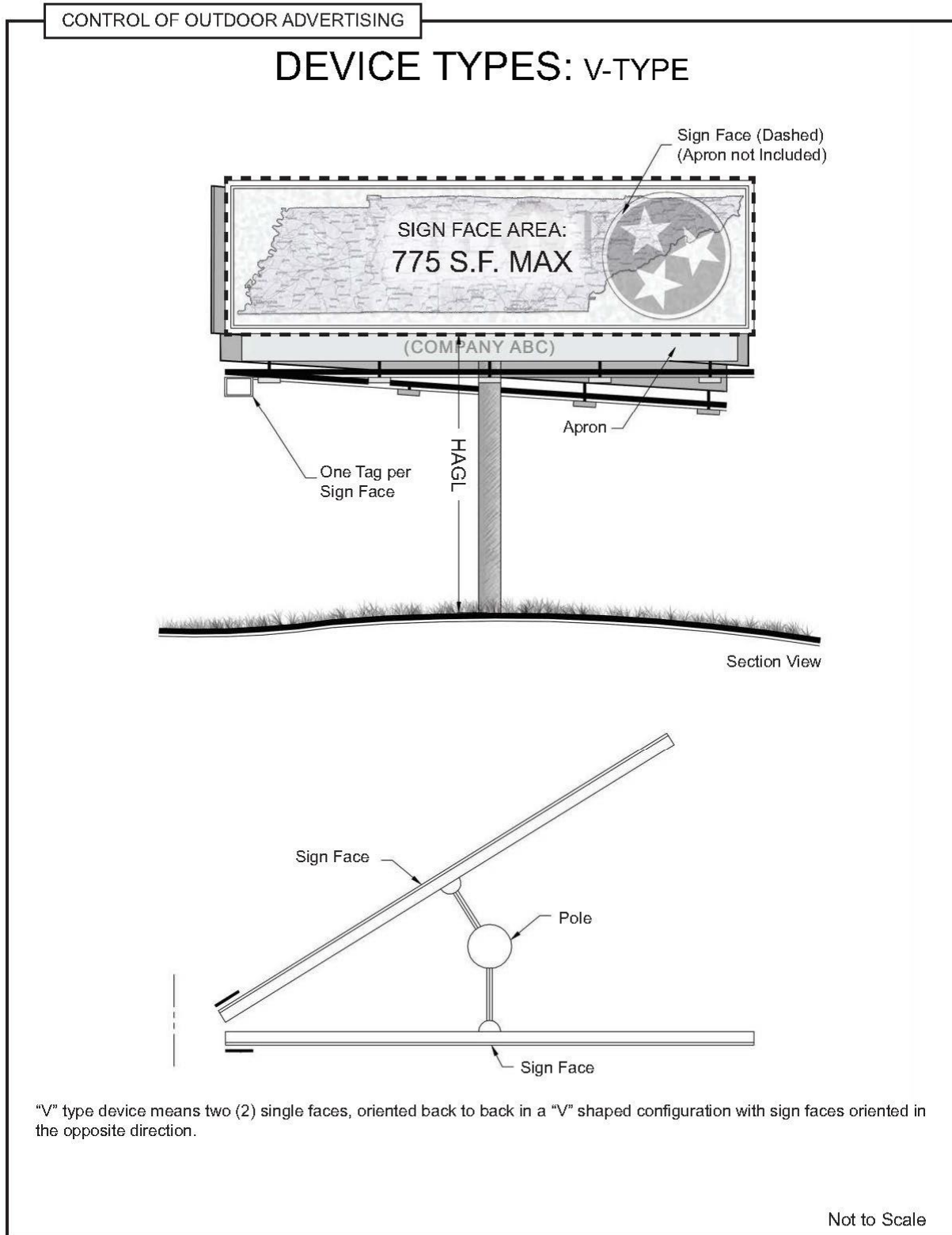

"V" type device means two (2) single faces, oriented back to back in a "V" shaped configuration with sign faces oriented in the opposite direction.

(g) Device Types: Stacked Display

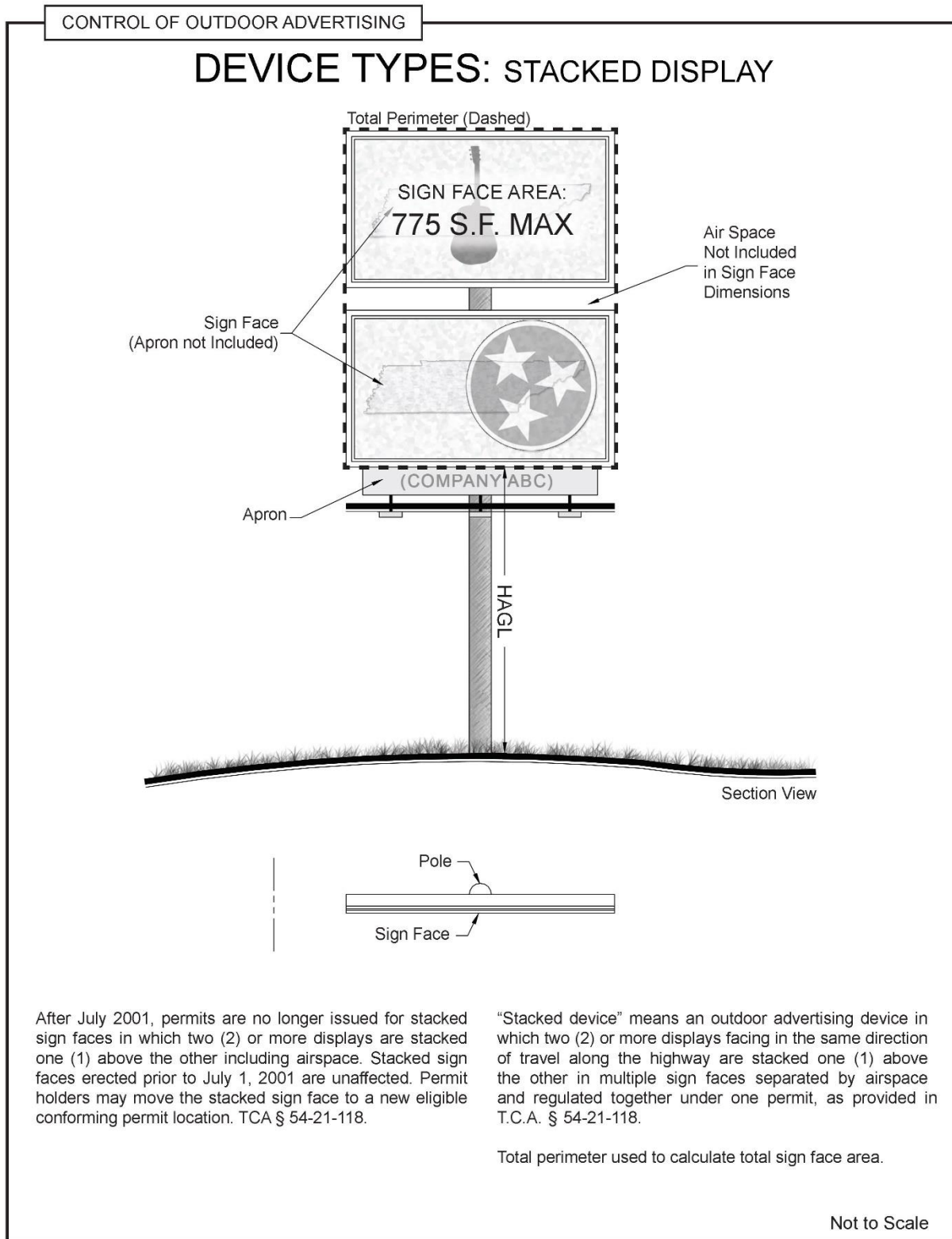

(h) Unzoned Commercial or Industrial

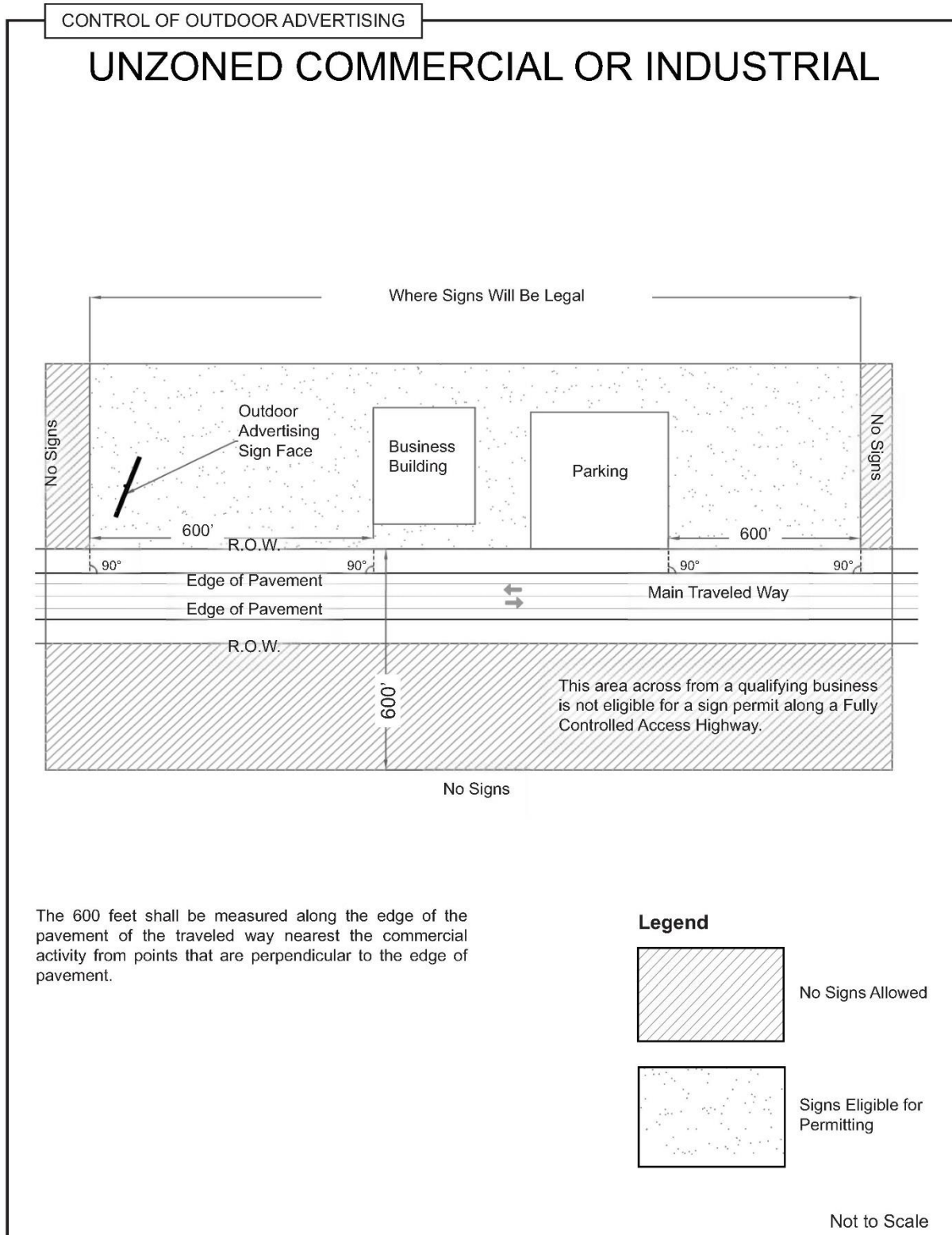

(i) Sign Face Size & Parts

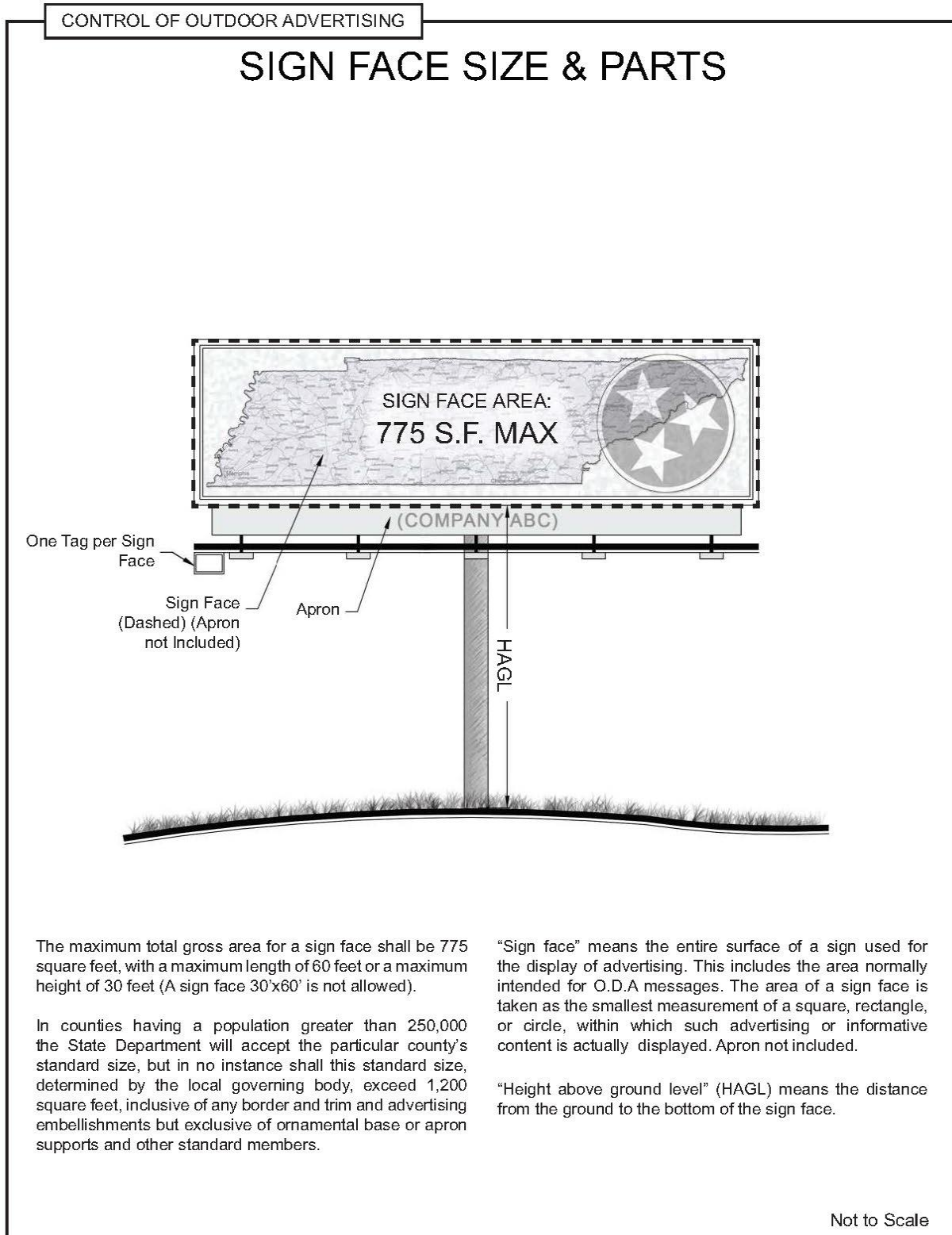

(i) Sign Face Size

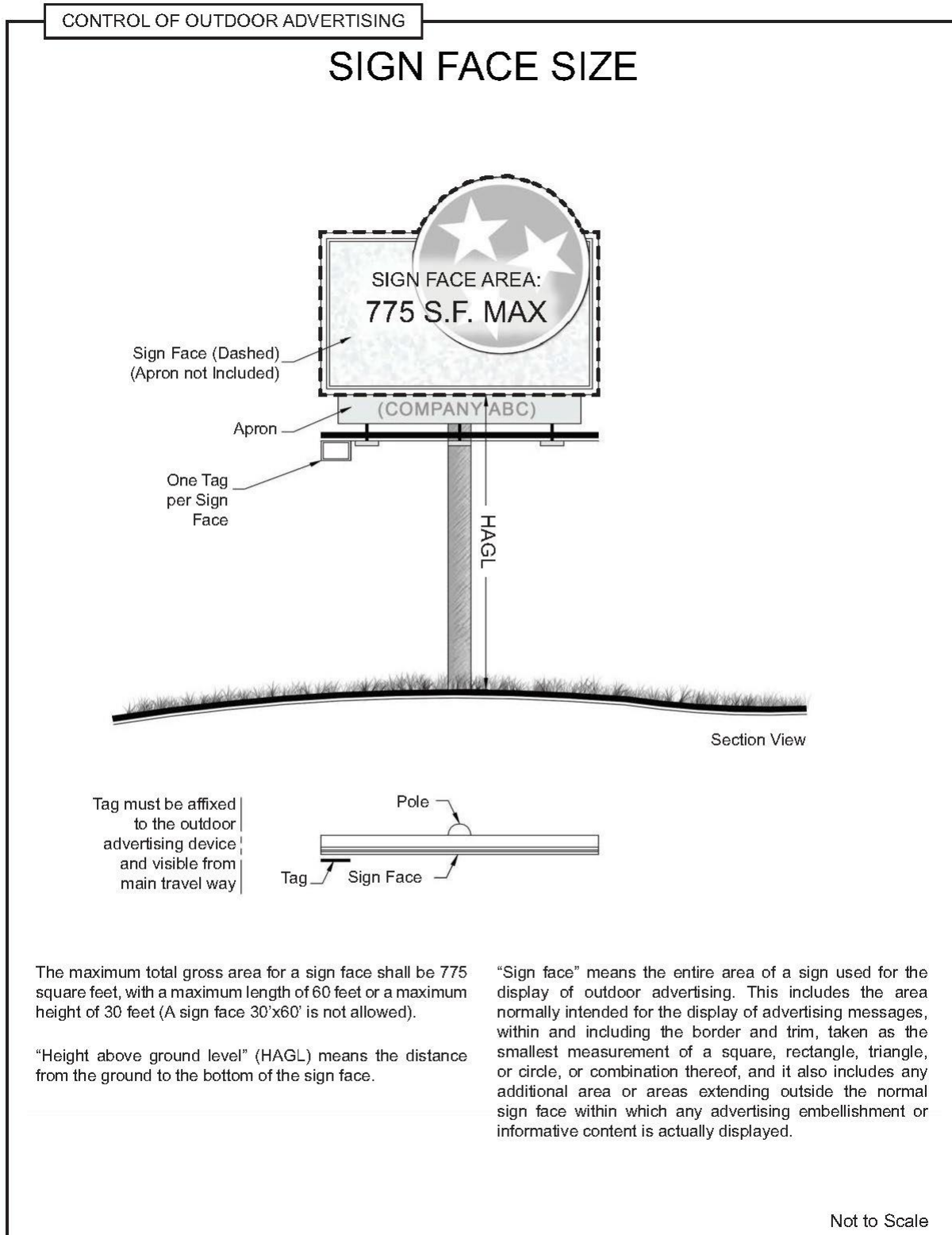

(k) Incorrect Sign Face Size

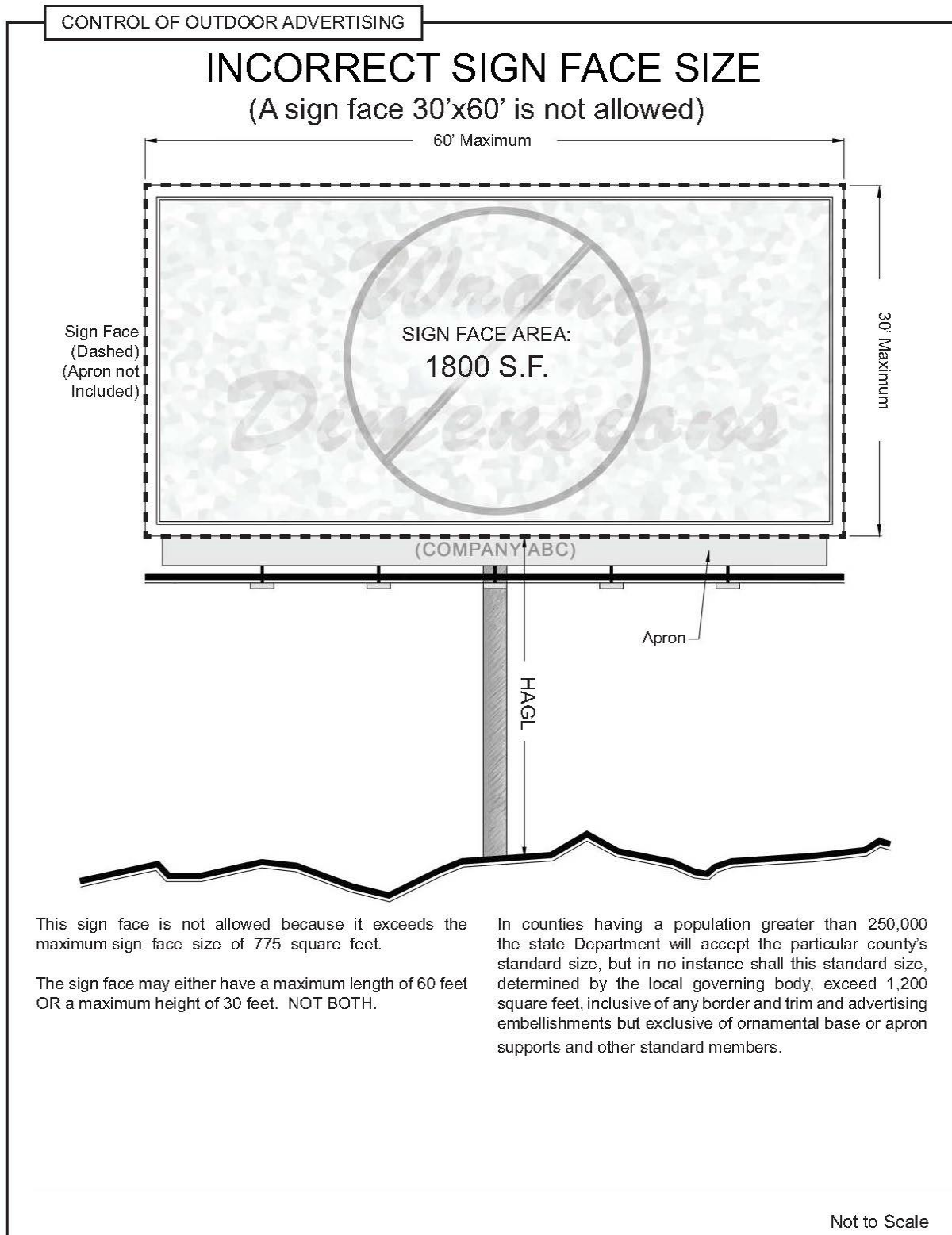

(I) Sign Spacing: Measurement Methods

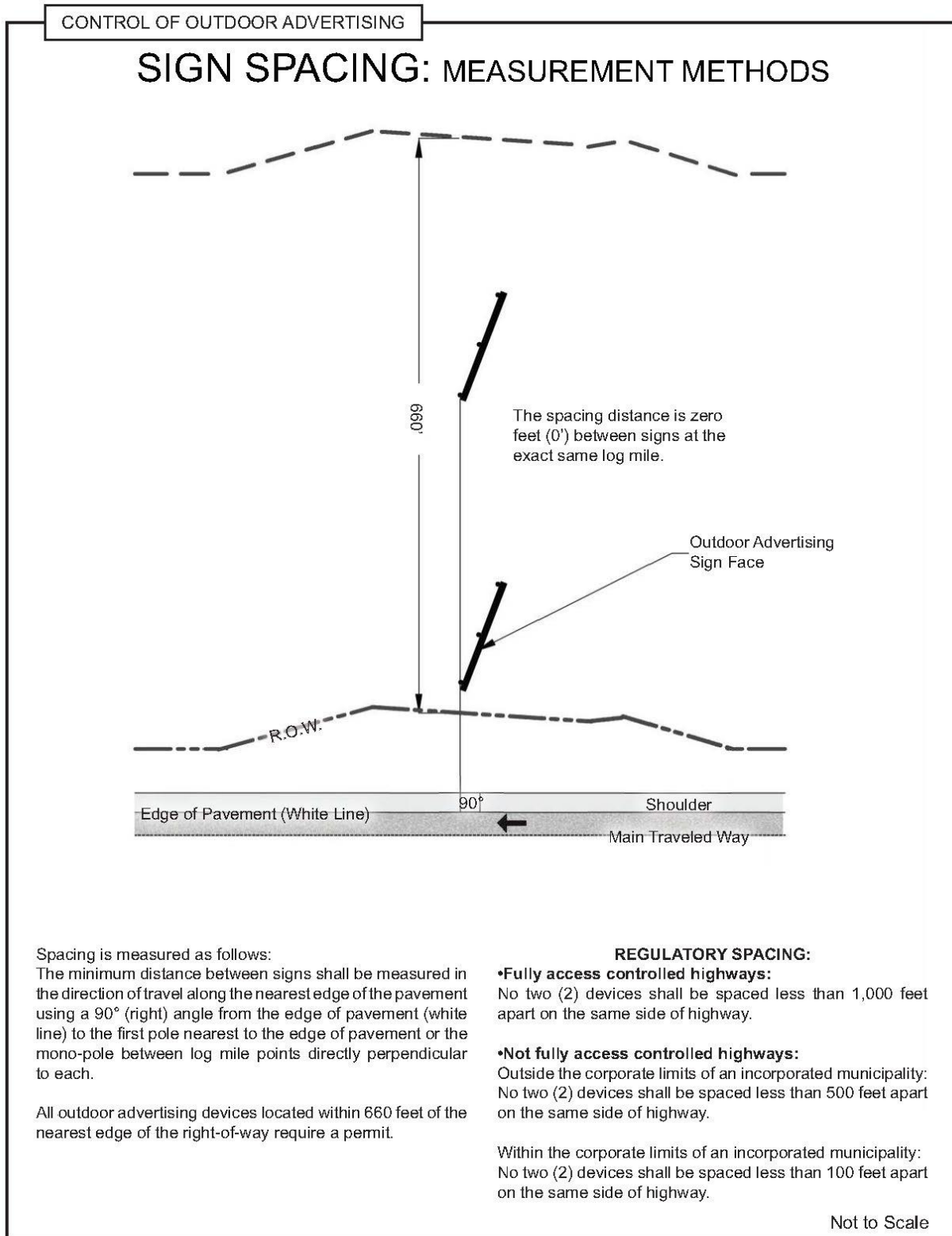

(m) Sign Spacing: Measurement Methods

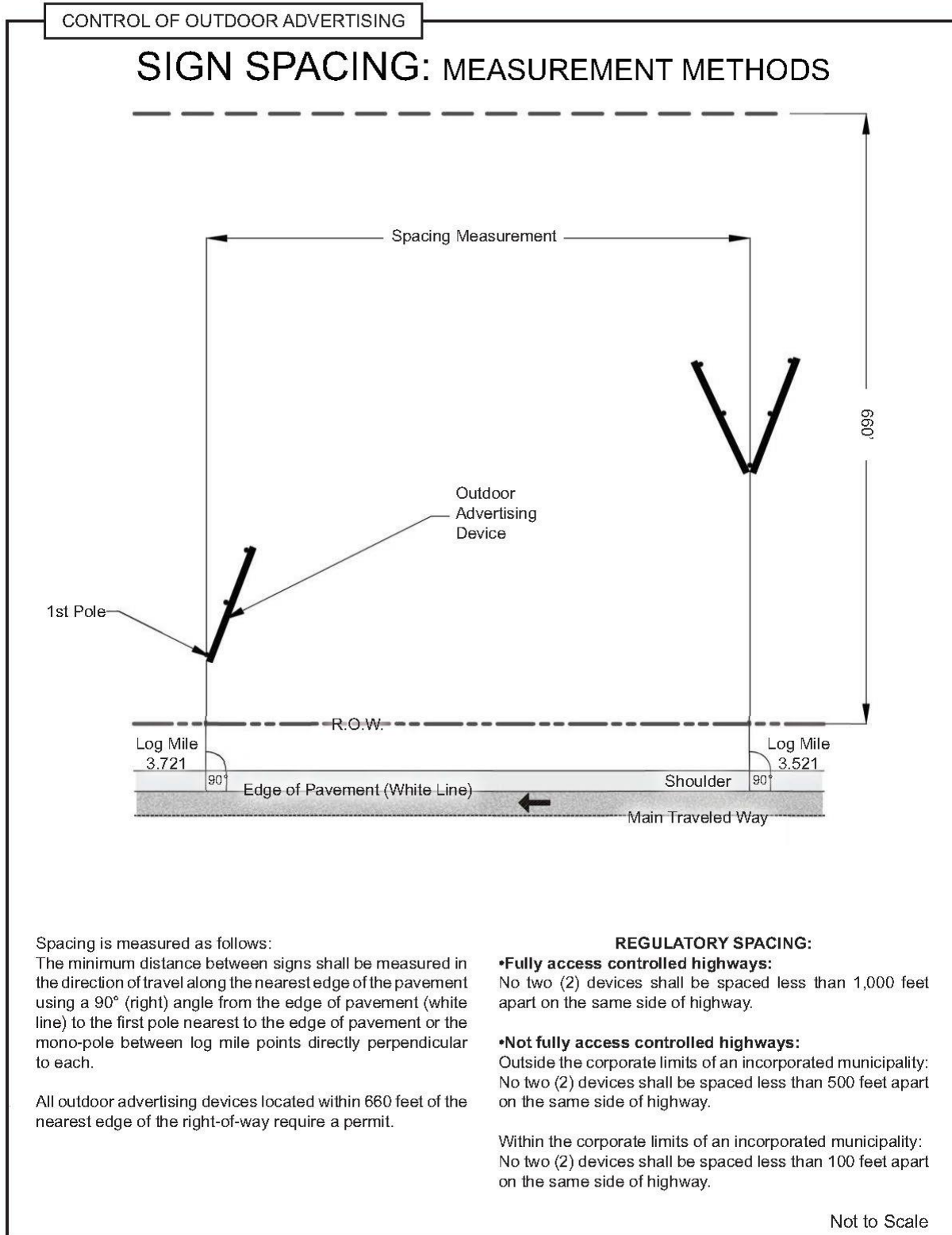

(n) Sign Spacing: Measurement Methods

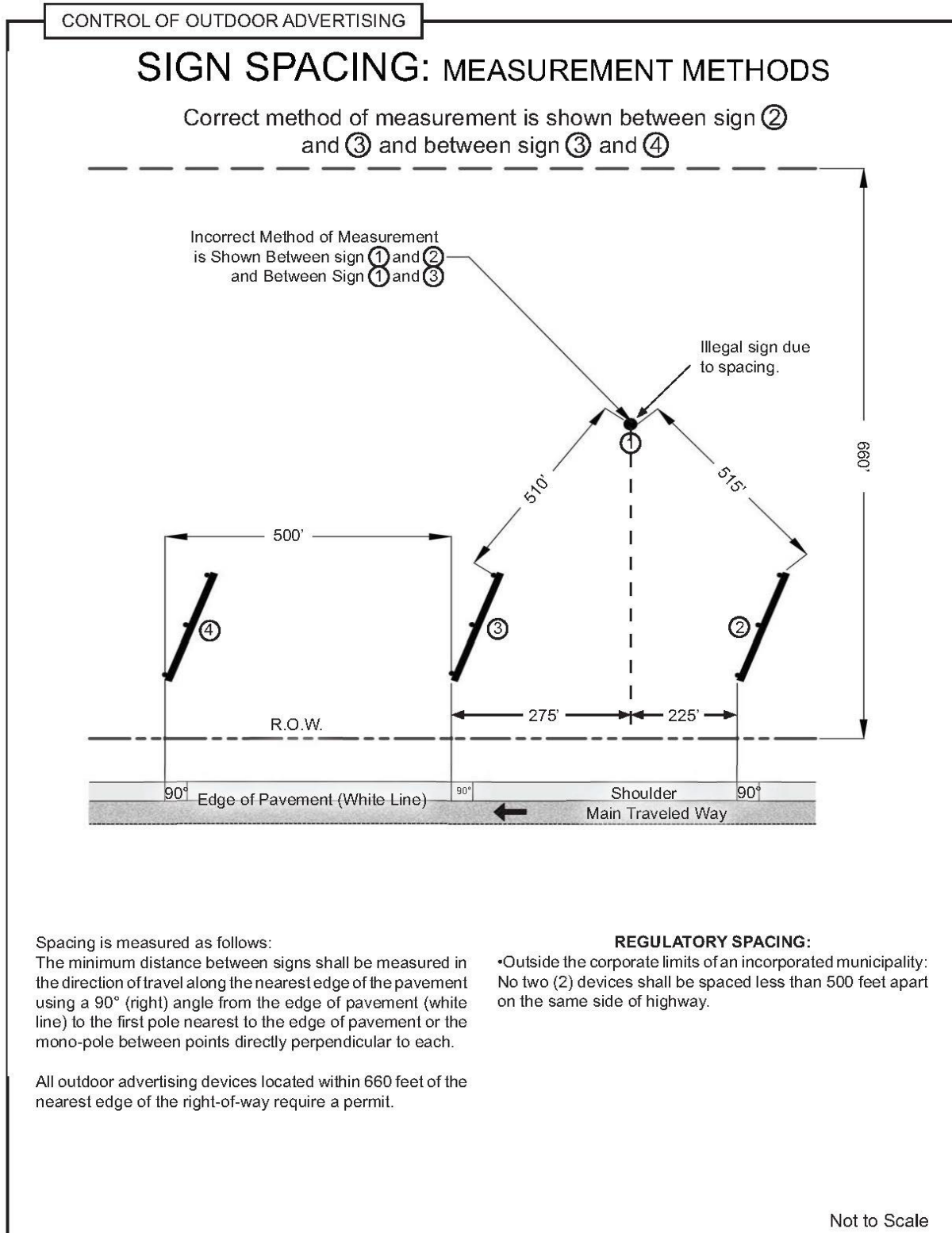

(o) Sign Spacing: Measurement Along A Curve

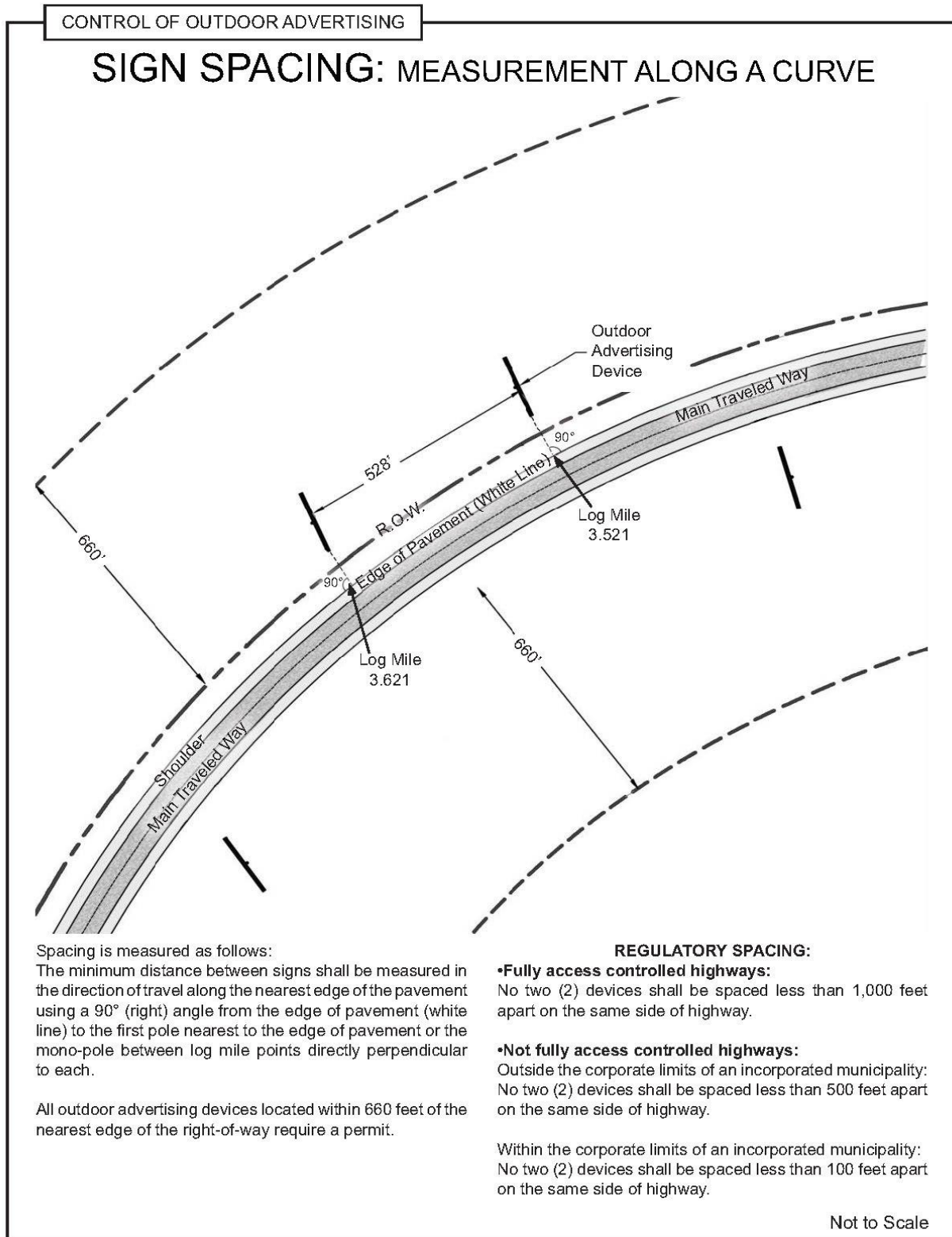

(p) Spacing Exception

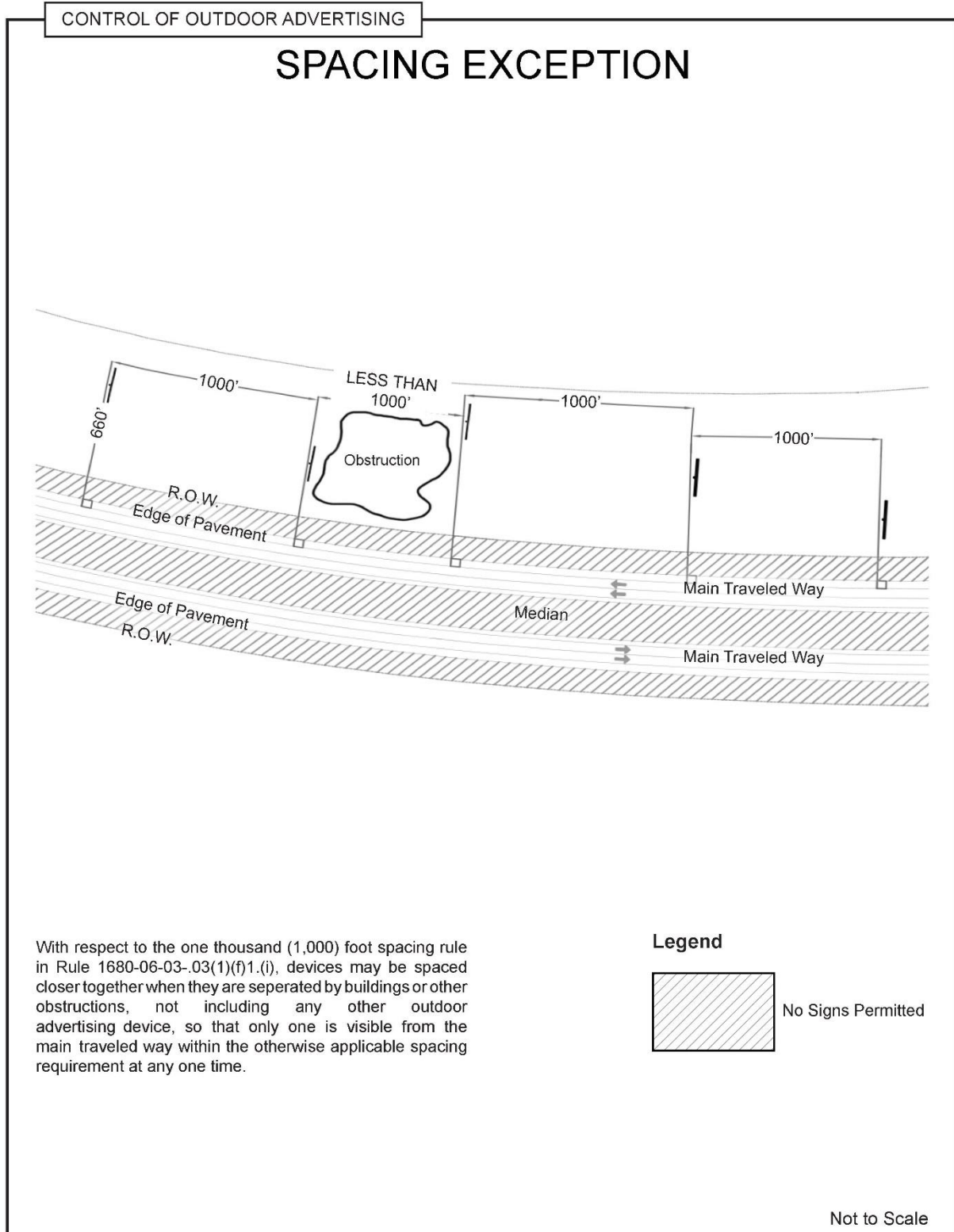

(g) Ramp Control: Outside the City Limits

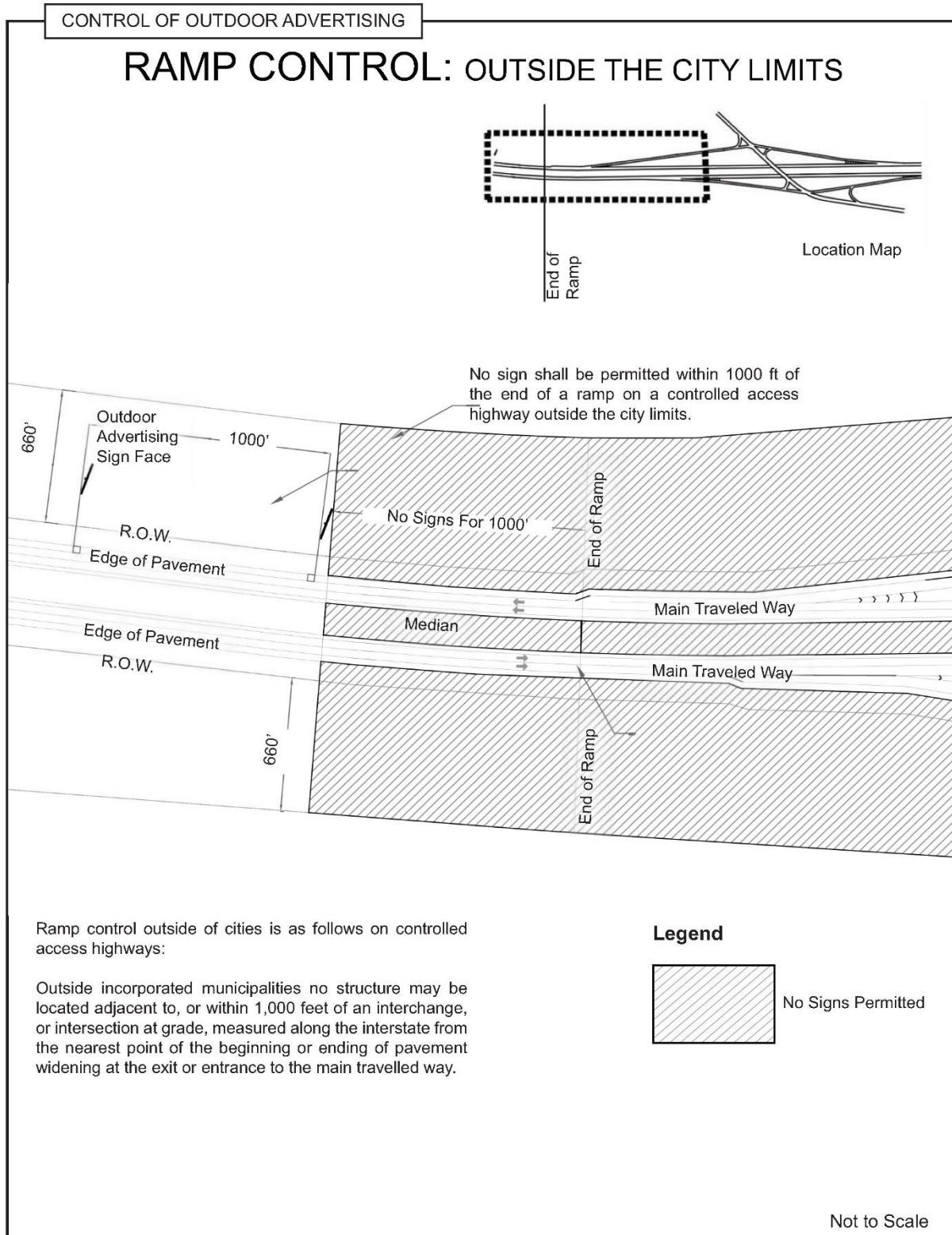

(r) Sign Spacing: Not Fully Controlled Access Control

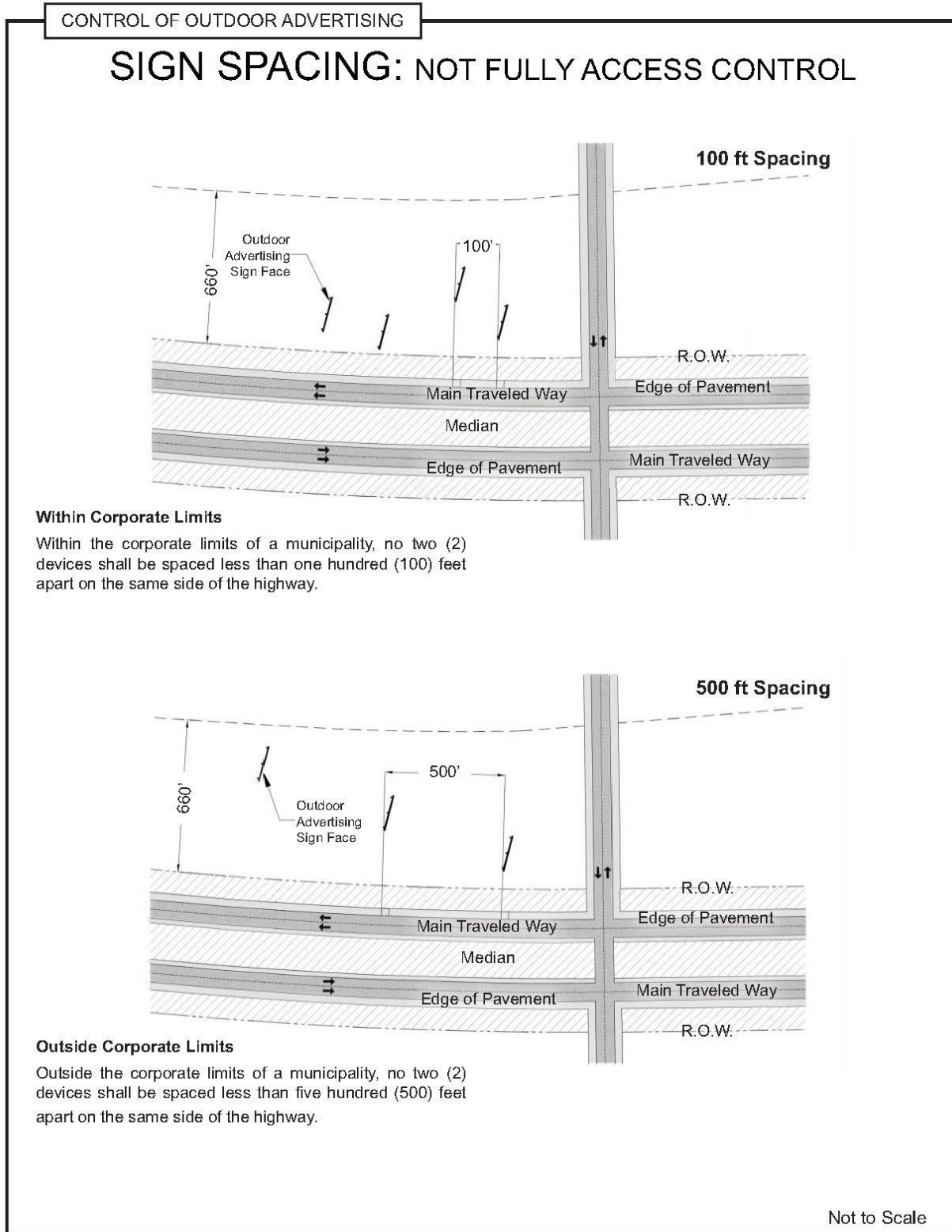

(s) On-Premises Device

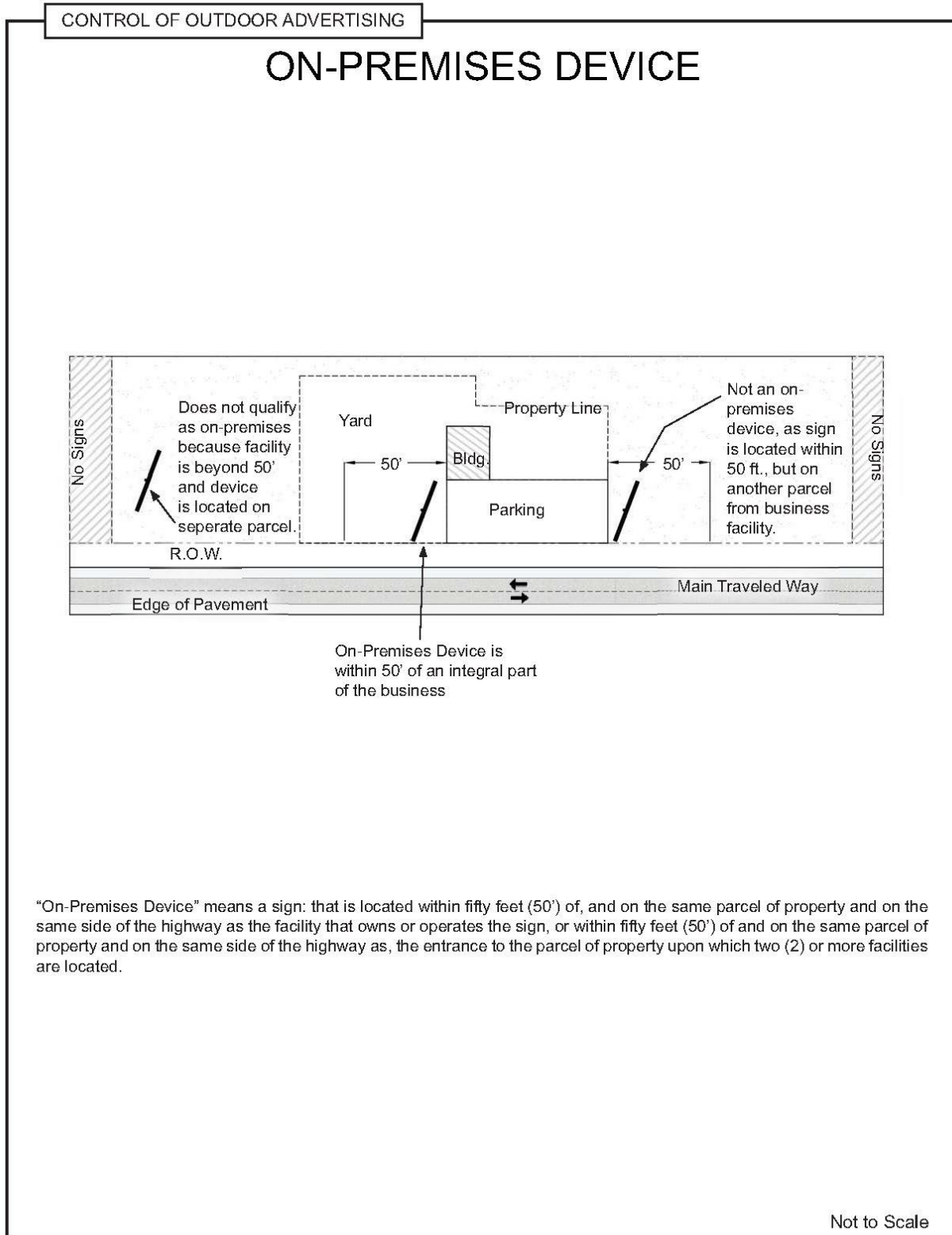

(t) Vegetation Control: Example Only

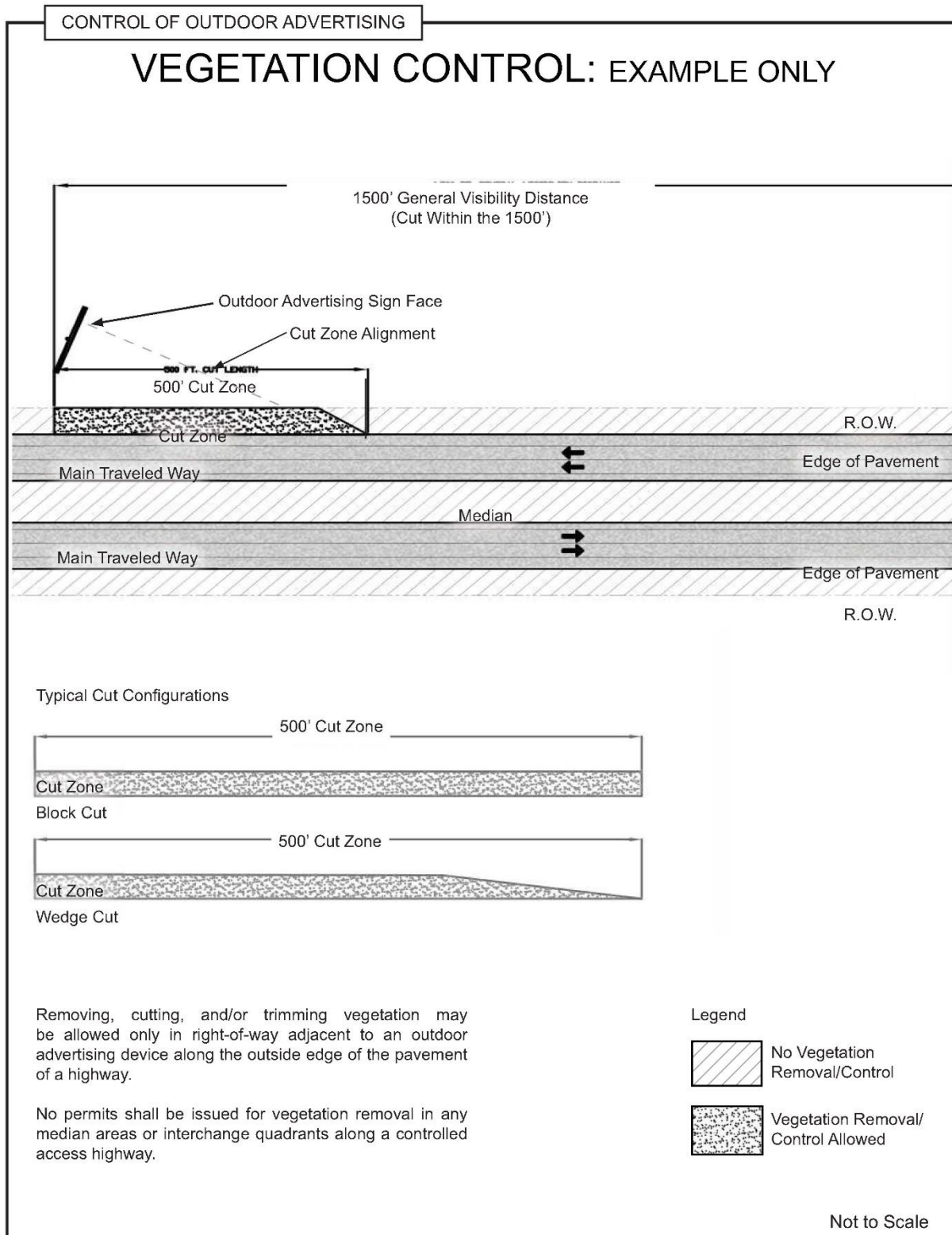

(u) Vegetation Control Removal Guide

CONTROL OF OUTDOOR ADVERTISING

VEGETATION CONTROL REMOVAL GUIDE

Right-of-Way Boundary

Cutting debris must be removed from the Right-of-Way

Stump shall be cut to ground level.

- All stumps of cut brush and trees shall be cut to ground level.
- Upon completion of work, all cut brush, limbs, and debris resulting from the work shall be removed and the work area left in an orderly condition.
- Bare soil in foreground shall be seeded and covered with straw.
- Any damage to right of way fence must be repaired.

Not to Scale

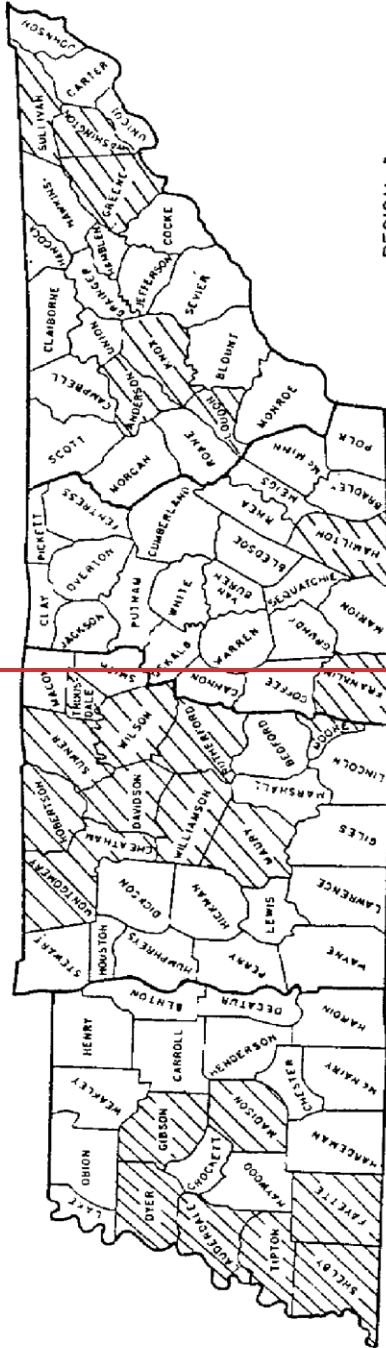

REGION I

- Anderson
- Blount
- Campbell
- Carter
- Claiborne
- Cocke
- Craiginger
- Greene
- Hamblen
- Hancock
- Hawkins
- Jefferson
- Johnson
- Knox
- Loudon
- Monroe
- Morgan
- Roane
- Scott
- Sevier
- Sullivan
- Unicoi
- Union
- Washington

REGION II

- Bledsoe
- Bridley
- Cannon
- Clay
- Coffee
- Cumberland
- DeKalb
- Fentress
- Franklin
- Grundy
- Hamilton
- Jackson
- McMinn
- Marion
- Meigs
- Overton
- Pickett
- Polk
- Putnam
- Rhea
- Sequatchie
- Van Buren
- Warren
- White

REGION III

- Bedford
- Cheatham
- Davidson
- Giles
- Hickman
- Houston
- Humphreys
- Lawrence
- Lewis
- Lincoln
- Macon
- Marshall
- Maury
- Montgomery
- Moore
- Perry
- Robertson
- Rutherford
- Smith
- Stewart
- Sumner
- Trousdale
- Wayno
- Williamson
- Wilson

REGION IV

- Benton
- Carrroll
- Chester
- Crockett
- Decatur
- Eyer
- Fayette
- Gibson
- Hardeman
- Hardin
- Haywood
- Henderson
- Henry
- Lake
- Lauderdale
- McNairy
- Madison
- Obion
- Shelby
- Tipton
- Weakley

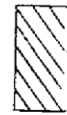

COMPREHENSIVELY ZONED COUNTIES

REGIONS OF THE TENNESSEE DEPARTMENT OF TRANSPORTATION

(Rule 1680-02-03-.09, continued)

STATE OF TENNESSEE, DEPARTMENT OF TRANSPORTATION
OUTDOOR ADVERTISING DEVICE APPLICATION AND PERMIT

Name of Applicant		Street Address		
City	State	Zip Code	Phone No.	Date of Application
Property Owner-Name & Address				
Lessor (if other than property owner)—Name & Address				
LOCATION OF OUTDOOR ADVERTISING DEVICE				
SIDE OF ROAD		North _____	East _____	
(CHECK ONE)		South _____	West _____	
Is the device on a controlled access highway?		Yes _____	Is the device within 1000 Ft. of an entrance or exit?	
No _____		Yes _____		No _____
Highway Number	Nearest Town or Place	Miles from Town or Place		
U.S. _____	Tenn. _____	_____ Miles		
Present Zoning of Site:		Sign Erection Date		
If unzoned commercial or industrial, name of qualifying activity.		Inside Corporate Limit of City or Town, if yes what City or Town		
No _____		Yes _____		
COUNTY:				
Distance to nearest outdoor advertising device in each direction. Same side of road				
CHECK TWO: _____ Ft. So., _____ Ft. No., _____ Ft. E., _____ Ft. W.				
Sign Material; Face and Uprights:		Area:	Shape:	
Wood _____	Combination _____	_____ Sq. Ft.	_____ Square	_____ Triangular
Metal _____	Lighted _____	Dimensions:	_____ Circular	_____ Glotted
		Height _____ Ft.	_____ Rectangular	_____ Other
		Width _____ Ft.		
NOTE: The Following Must Accompany This Application				
1) A sketch of the sign site location on a separate sheet of paper.				
2) A copy of a valid land lease or signed affidavit by the property owner stating permission has been given to erect a sign. (Property owner's signature must be notarized.)				
3) A check or money order in the amount of \$75.00 payable to the Tennessee Department of Transportation.				
FIELD INSPECTION REQUIREMENT: The applicant must mark the location for a proposed sign site with an easily visible flag or stake. Failure to properly mark a proposed site will result in the rejection of this application; the application fee will be retained as required by law.				
This application is for a permit for one facing of an outdoor advertising device. The permit is not transferable to another Outdoor Advertising Device.				
I hereby certify that I have personally examined and understand the "Rules and Regulations for the Control of Outdoor Advertising" and this application is made in compliance with same, and further certify that the statements made on the application are accurate and true to the best of my knowledge and understand that if investigation reveals that any of the information on the application is false the permit will be voided, tag confiscated, and the Outdoor Advertising Device will be declared illegal.				
I also certify that the only Vegetation Control allowed at this location for signs erected after April 20, 1983, will be to maintain the visibility as it existed on the date of erection.				
		Signed _____		
		Name Typed or Printed _____		
D.O.T. OFFICE USE ONLY				
DATE OF ISSUANCE	ISSUED BY	TAG AND PERMIT NUMBER 19 _____		

ROW FORM 201
REVISED 07-05-84
DT 0258

Return White, Yellow and Pink Copies to
the Outdoor Advertising Control Office
—Retain Orange (last) copy for your files—

(Rule 1680-02-03-.09, continued)

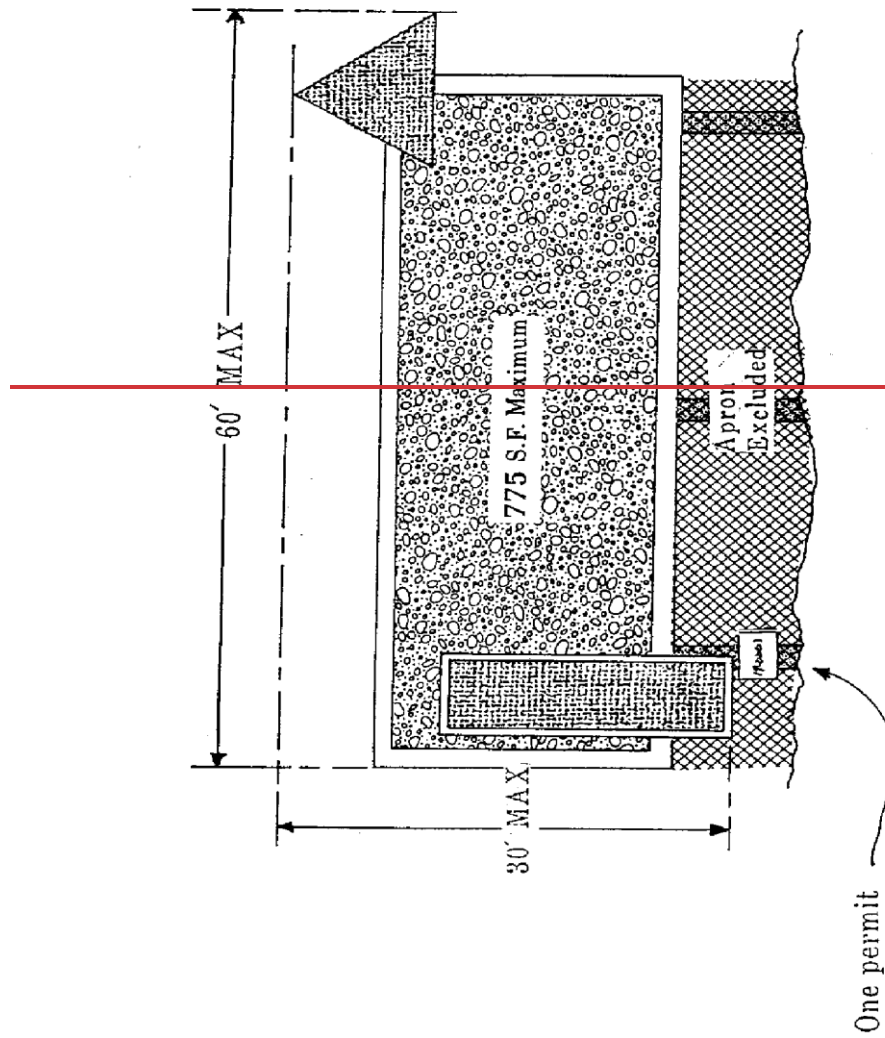

NOTE: IN COUNTIES WITH A POPULATION OF 250,000 OR GREATER, THE MAXIMUM AREA OF THE FACE WILL COMPLY WITH COUNTY AREA STANDARDS, HOWEVER, IN NO INSTANCE WILL THE AREA EXCEED 1200 SQUARE FEET.

(Rule 1680-02-03-.09, continued)

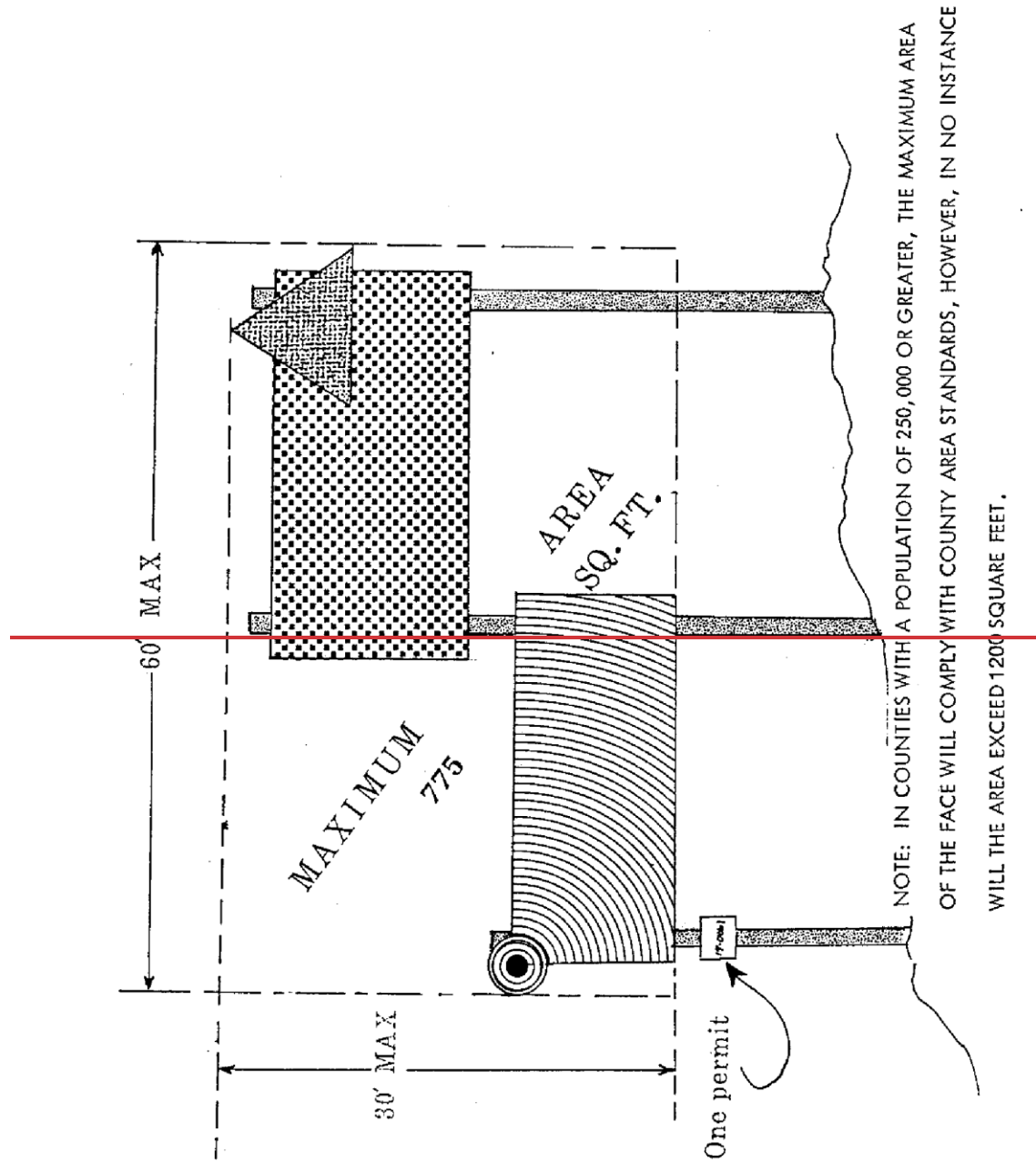

(Rule 1680-02-03-.09, continued)

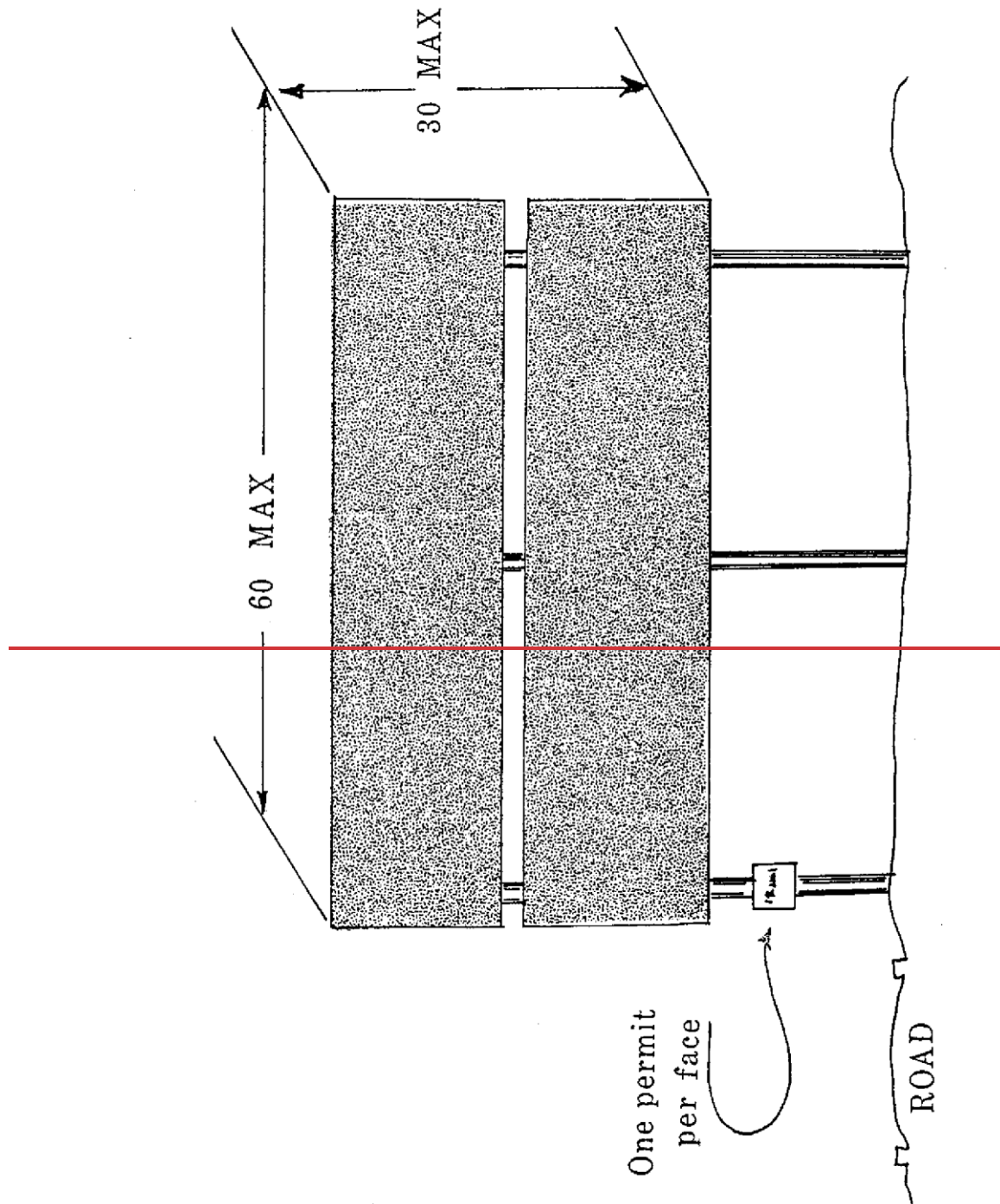

(Rule 1680-02-03-.09, continued)

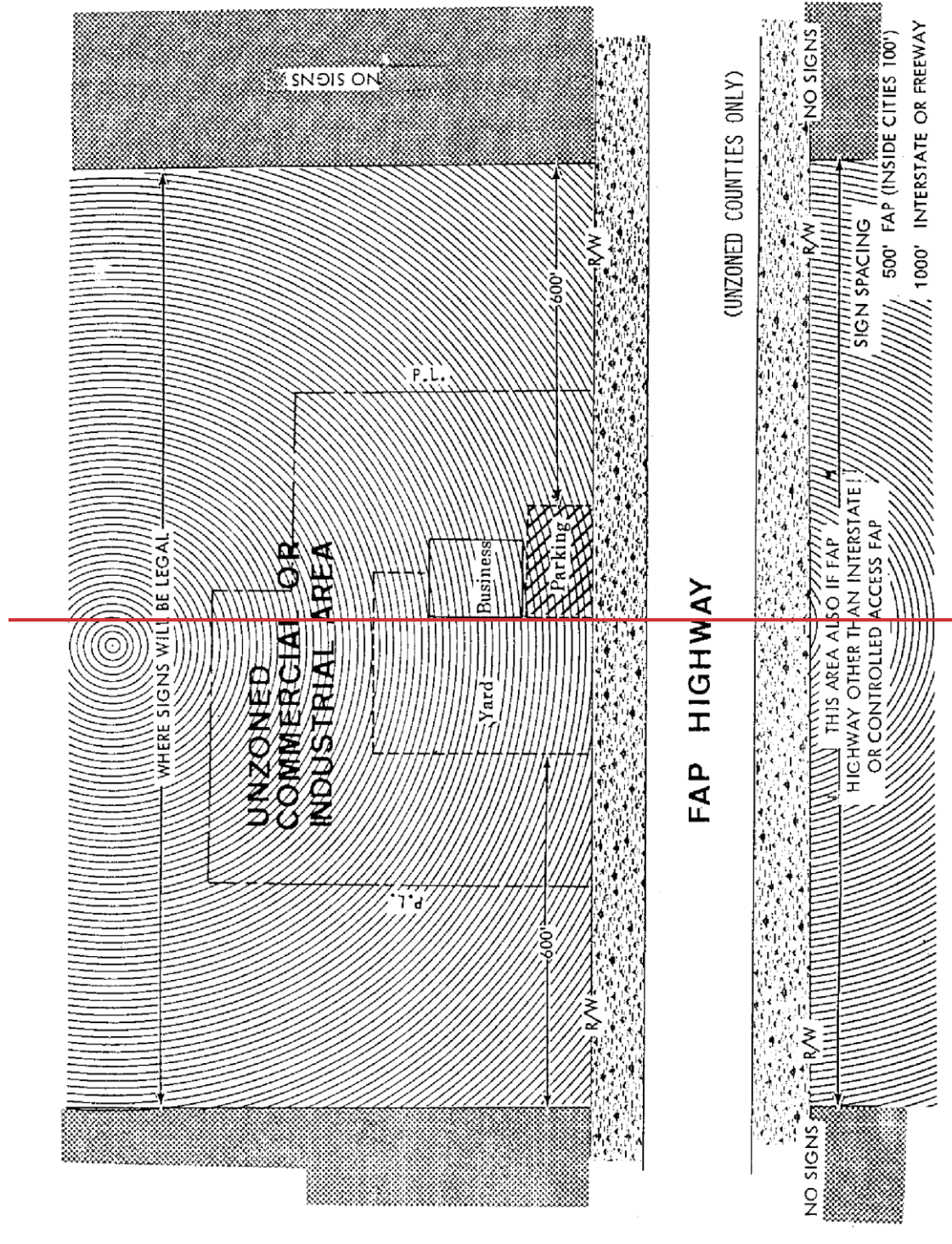

(Rule 1680-02-03-.09, continued)

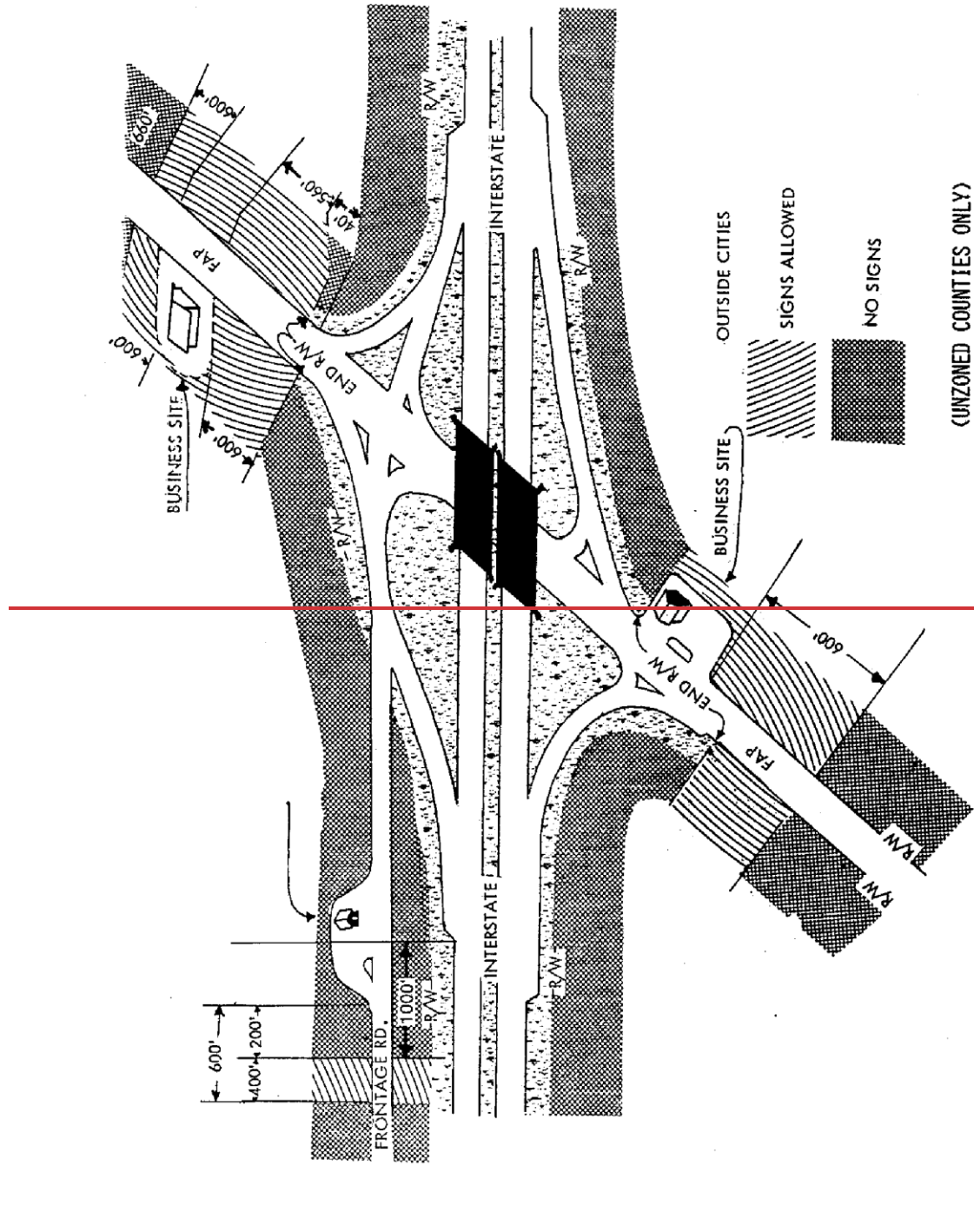

(Rule 1680-02-03-.09, continued)

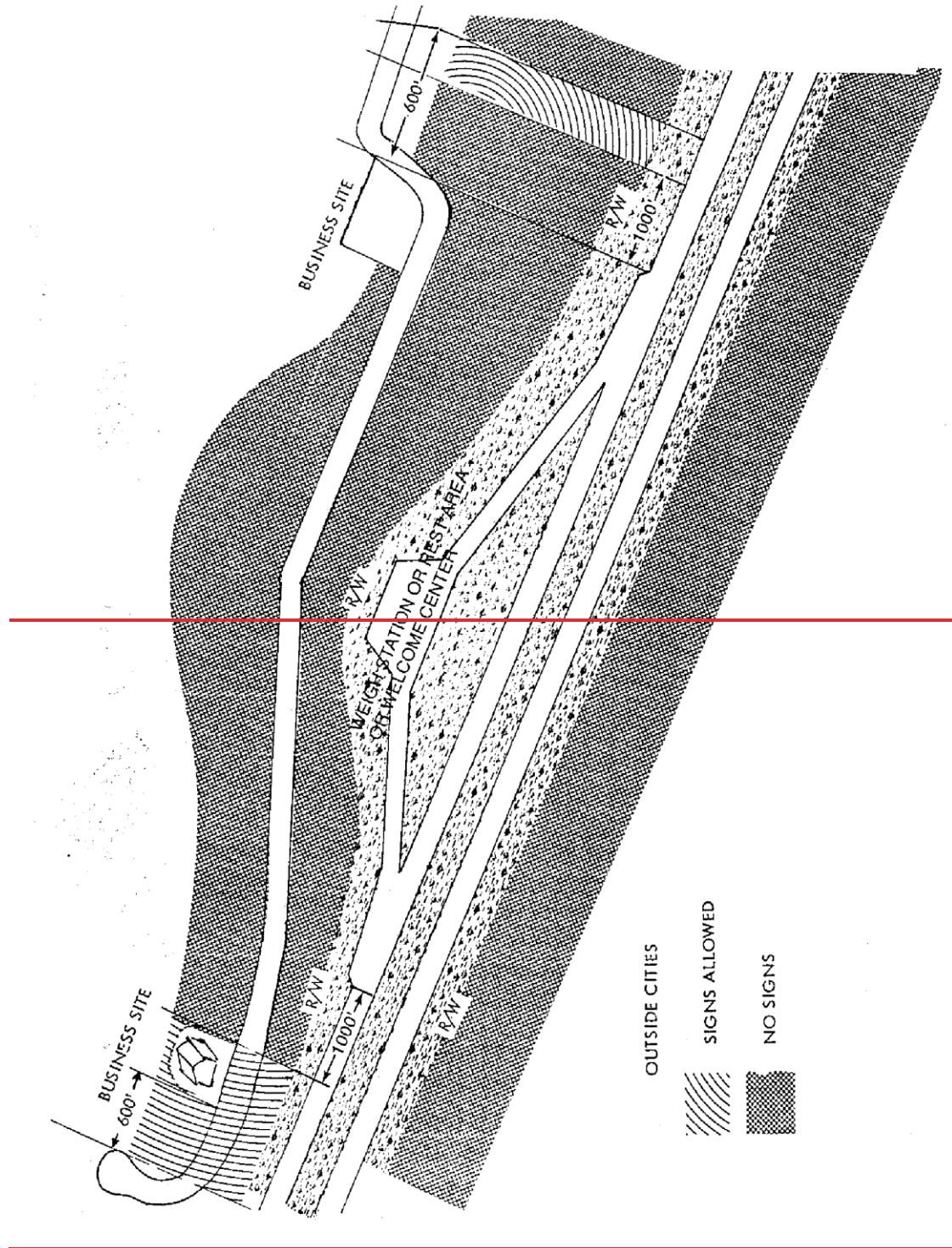

(Rule 1680-02-03-.09, continued)

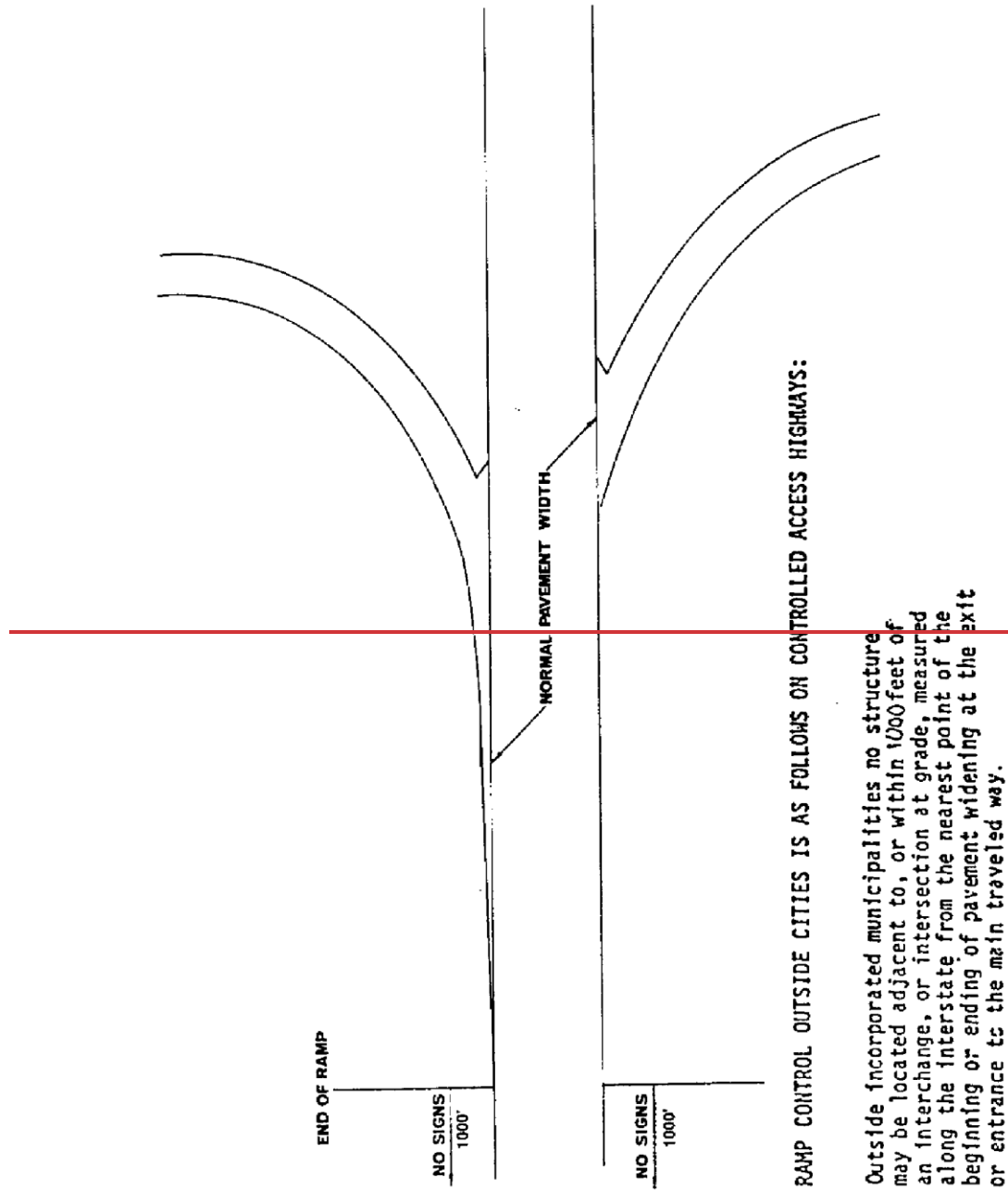

(Rule 1680-02-03-.09, continued)

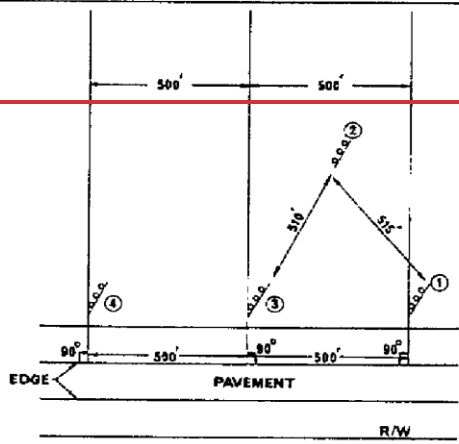
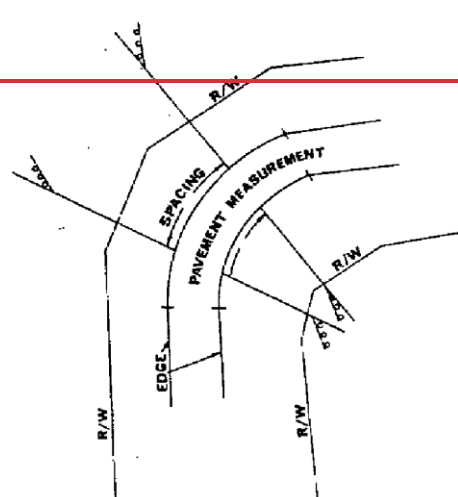
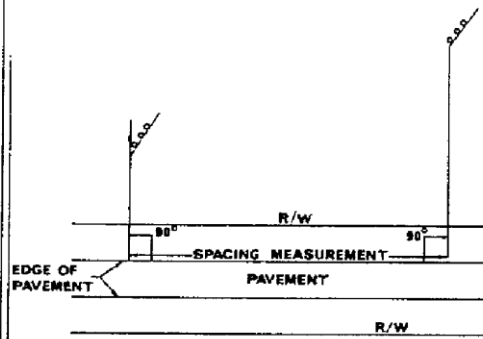
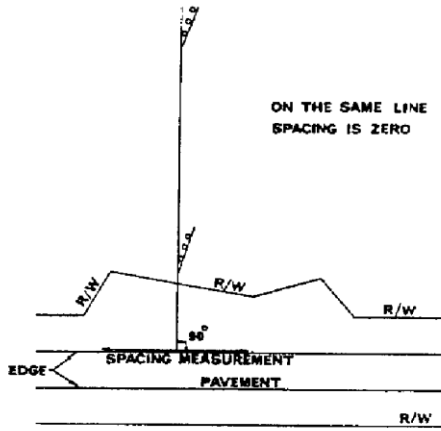

SIGN NO. ② DOES NOT MEET SPACING REQUIREMENT

DENOTES SIGN ^{S.P.O.}

SPACING IS MEASURED AS FOLLOWS:

The minimum distance between signs shall be measured along the nearest edge of the pavement between points directly opposite the signs along each side of the highway.

(Rule 1680-02-03-.09, continued)

Authority: T.C.A. § 54-21-~~23~~111 and 23 U.S.C § 131. Administrative History: Original rule filed June 9, 1977; effective July 11, 1977. Repeal and new rule filed January 27, 1989; effective March 13, 1989.

~~1680-02-03-.10 THROUGH 1690-2-3-.13 REPEALED.~~

~~Authority: T.C.A. § 54-21-23 and U.S.C § 131. Administrative History: Original rule filed October 10, 1984; effective November 9, 1984. Repeal filed January 27, 1989; effective March 13, 1989.~~