

ISOMETRIC VIEW
SHOWING DIMENSIONS, 4:1 SLOPE

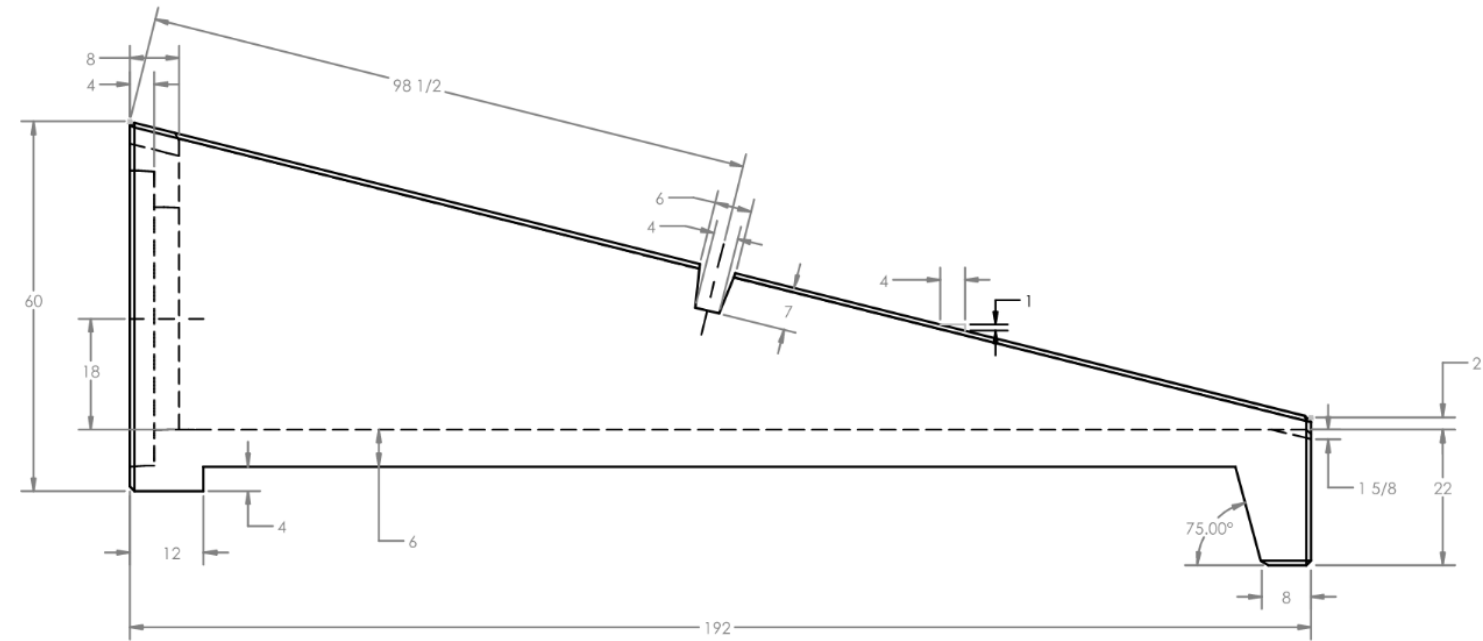

NOTES:

1. SPECIFICATIONS: TDOT 2015 EDITION WITH CURRENT ADDENDA.
2. DESIGN SPECIFICATION: AASHTO LRFD SPECIFICATIONS, CURRENT EDITION.
3. CONCRETE TO BE CLASS "A", F'C = 4,500 P.S.I.
4. REINFORCING STEEL PROVIDED AS RE-BAR TO BE IN ACCORDANCE WITH ASTM A615, F'Y = 60,000 P.S.I.
5. REINFORCING STEEL PROVIDED AS WELDED WIRE REINFORCEMENT (WWR) TO BE IN ACCORDANCE WITH ATM A1064, DEFORMED WIRE WITH F'Y - MIN = 70,000 P.S.I.
6. WELDED WIRE REINFORCEMENT IS PROVIDE IN SINGLE CUSTOM MATS. THE CUSTOM MATT SHALL BE BENT AS REQUIRED TO REINFORCE WALLS, HELLS, AND TROUGH.
7. SEE TDOT STANDARD DRAWING NOS. D-PE-36A AND D-PE-36B FOR ADDITIONAL CONSTRUCTION REQUIREMENTS.
8. BAR BENDS FOR RE-BAR SHALL BE IN ACCORDANCE WITH CRSI MANUAL OF STANDARD PRACTICE.
9. BENDS FOR WELDED WIRE FABRIC SHALL BE IN ACCORDANCE WITH THE MANUAL OF STANDARD PRACTICE AS PUBLISHED BY THE WIRE REINFORCEMENT INSTITUTE.
10. DIMENSIONAL TOLERANCES TO BE IN ACCORDANCE WITH TDOT STANDARD OPERATING PROCEDURES(SOP), SECTION 5-3, PART 3.

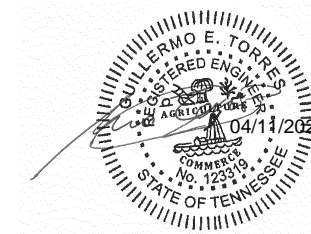

APPROXIMATED WEIGHT:
ENDWALL: 6.60 TON



TDOT - TYPE "U" CROSS DRAIN ENDWALL

36" ENDWALL (4:1 SLOPE) - GENERAL DETAIL

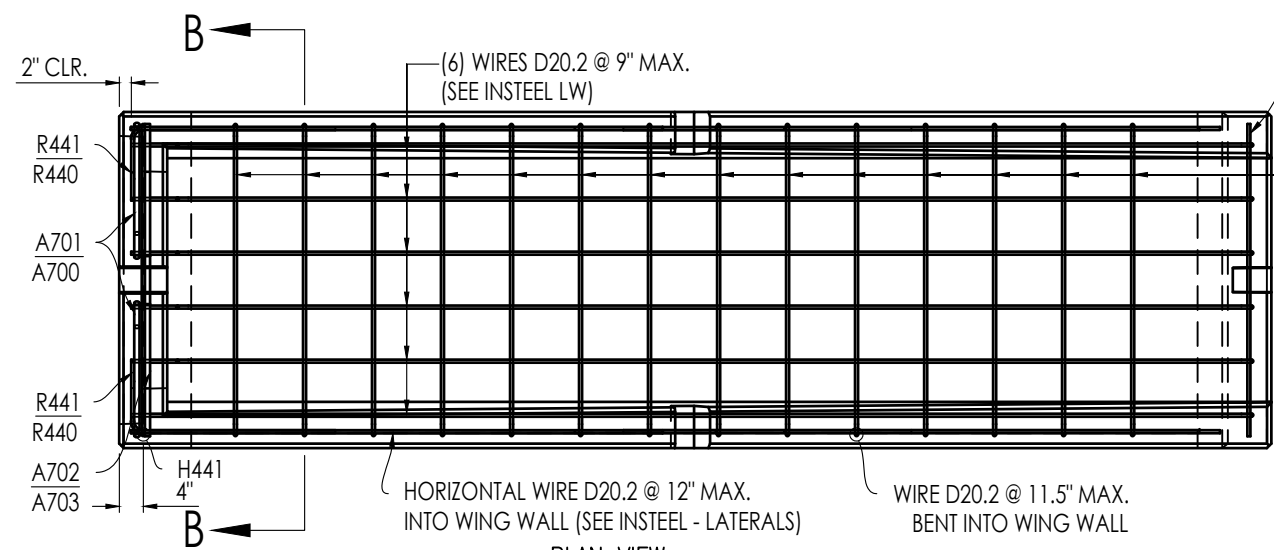

PLAN VIEW
SCALE 3/8" = 1'-0"

(3) WIRE D20.2 @ 6.5" MAX.
(HORIZONTAL IN TOE WALL)
(SEE INSTEEL MS-WWR1.4)

(14) WIRE D20.2
@ 11.5" MAX.
(SEE INSTEEL CW)

WIRE AREA EXAMPLE:
WIRE D20.2: DESIGNATES
DEFORMED WIRE WITH
AREA = 0.202 in²/ WIRE

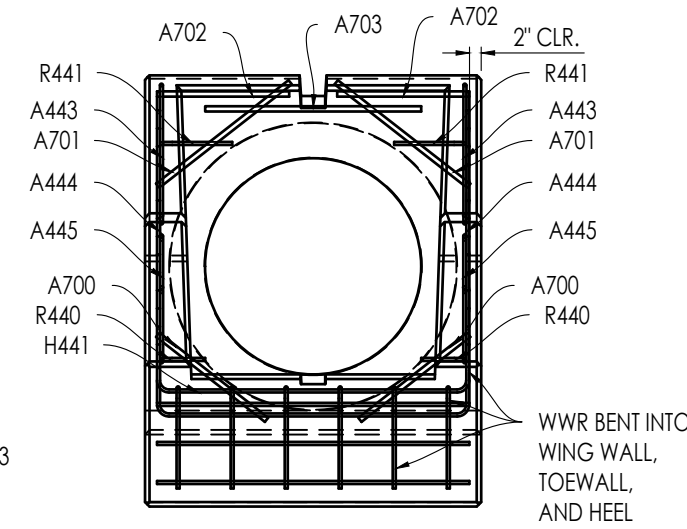

END ELEVATION
SCALE 3/8" = 1'-0"

REBAR CUT LIST					
BAR #	SIZE	QTY (ea)	LENGTH		WEIGHT (lb)
			A (in.)	B (in.)	
A443	4	2	91 1/2	N/A	10.2
A444	4	2	36	N/A	4.0
A445	4	2	86 1/2	N/A	9.6
A700	4	2	23	N/A	2.6
A701	7	2	28	N/A	9.5
A702	7	2	22	N/A	7.5
A703	7	1	36	N/A	6.1
H441	4	1	52	54	8.9
R440	4	2	178	7 1/2	20.7
R441	4	2	34	12	5.1
TOTAL					84.2

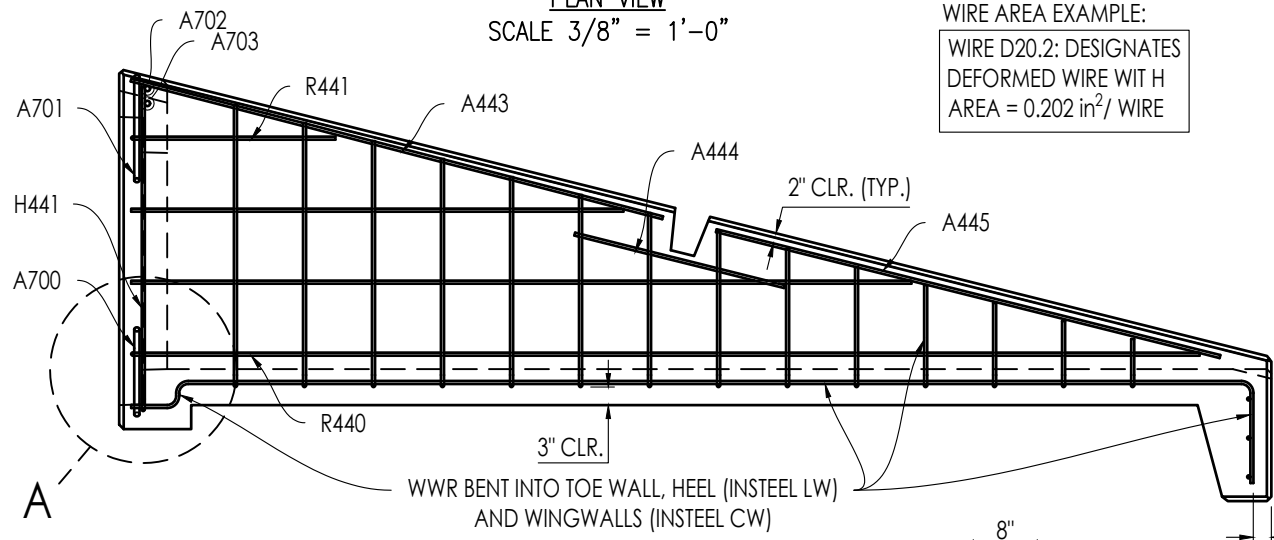

WINGWALL ELEVATION
SCALE 3/8" = 1'-0"

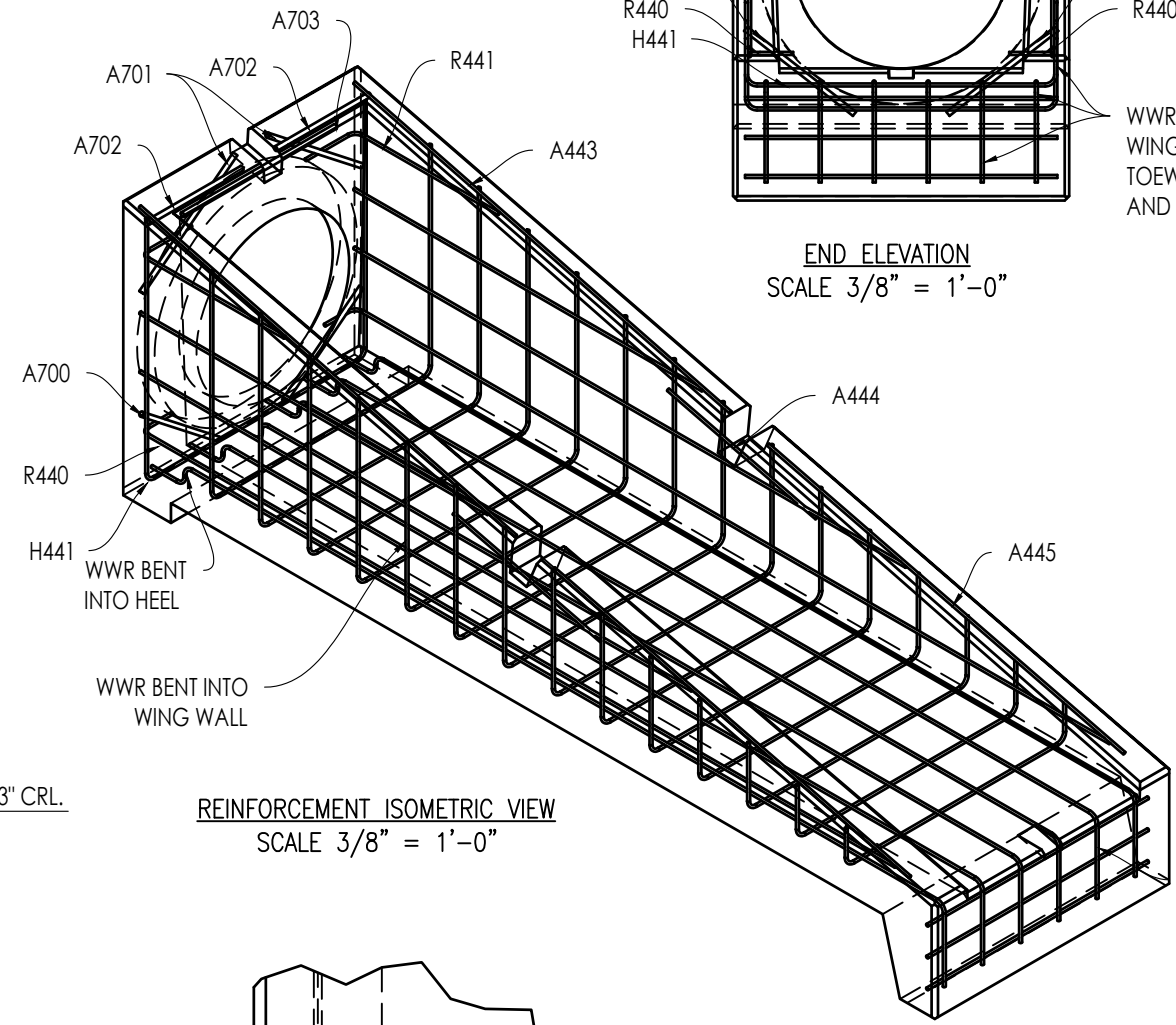

REINFORCEMENT ISOMETRIC VIEW
SCALE 3/8" = 1'-0"

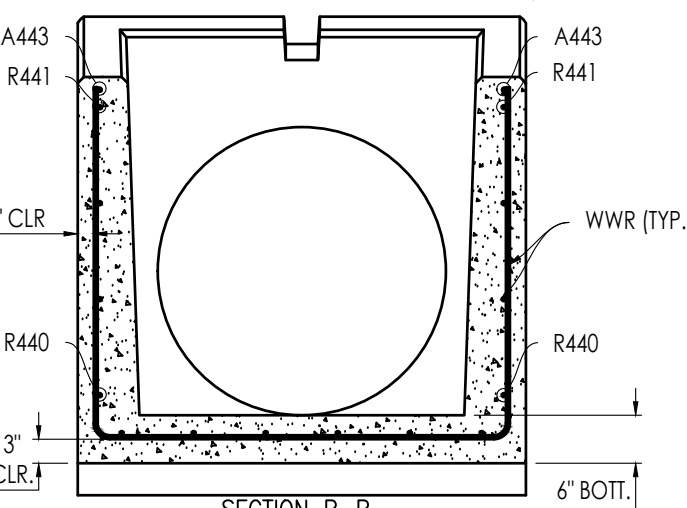
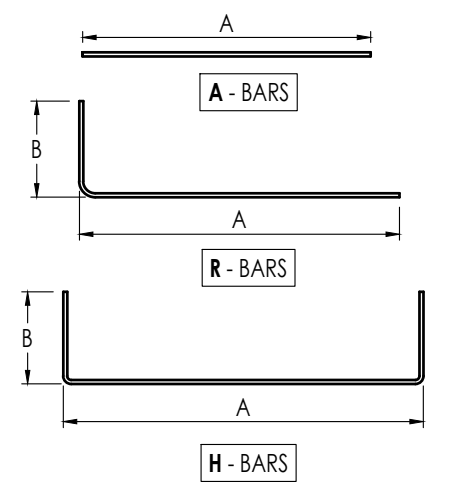

SECTION B-B
SCALE 1/2" = 1'-0"

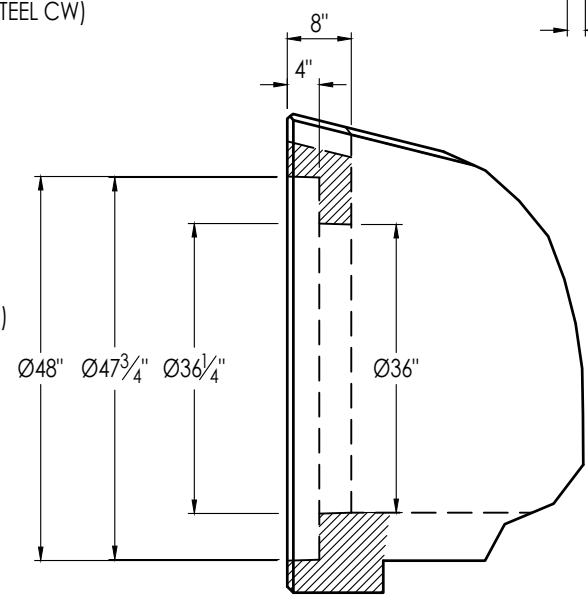

PIPE OPENING DETAIL
SCALE 1/2" = 1'-0"

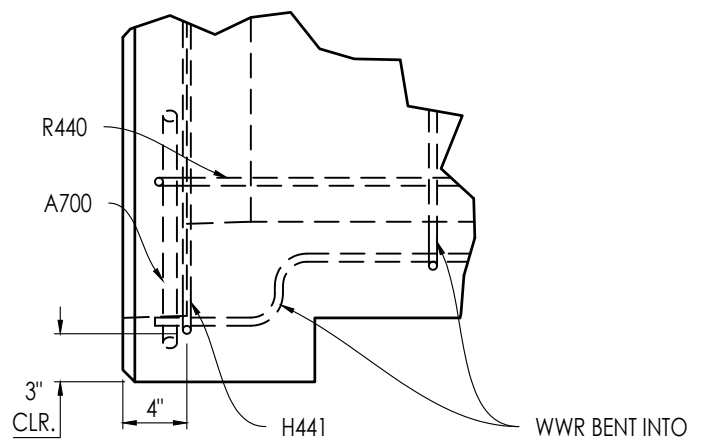

DETAIL A
SCALE 1" = 1'-0"

- NOTES:
- REFER TO TDOT STANDARD PLANS, SHEET D-PE-36A & D-PE-36B FOR ADDITIONAL INFORMATION.
 - REFER TO INSTEEL DRAWING "MS-WWR1.4", TITLE "36" Set 4:1", DATED 03/07/2024, FOR WWR DETAIL AND LAYOUT.

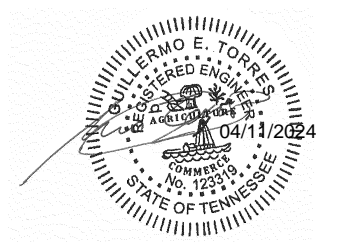

APPROXIMATED WEIGHT:
ENDWALL: 6.60 TON



TDOT - TYPE "U" CROSS DRAIN ENDWALL
36" ENDWALL (4:1 SLOPE) - REINFORCEMENT DETAIL

2.1

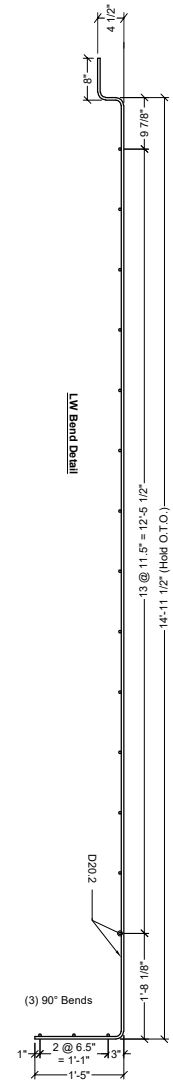
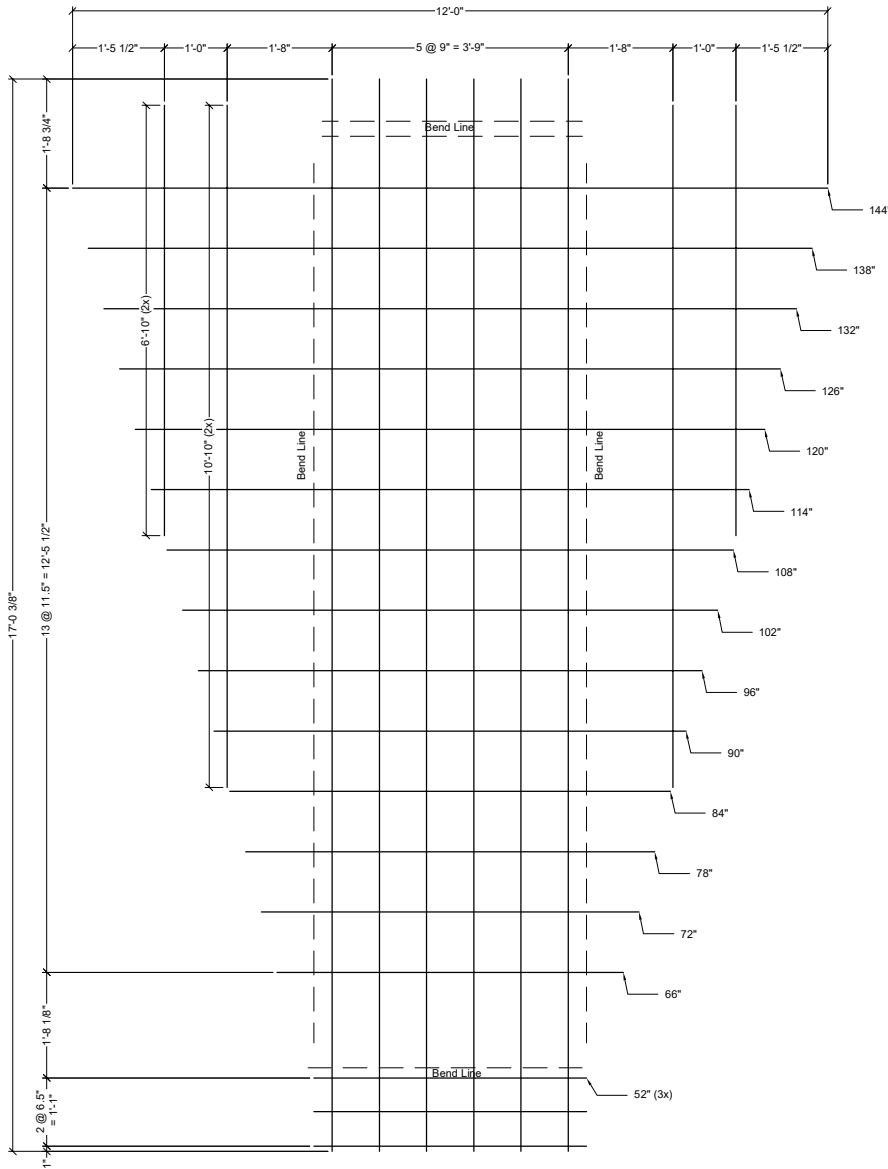
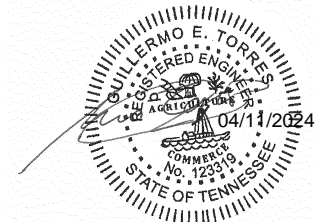
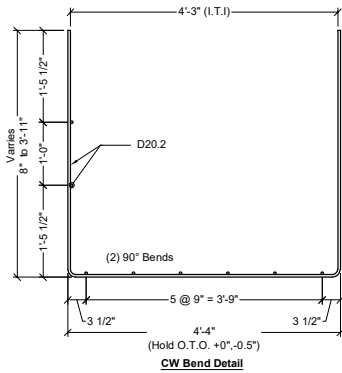

36" SET 4:1 Mesh
 V1xV2 D20.2xD20.2 109'(+16", +16") x 17'-0.375'(20.75", 1")
 V1 = 16" Oh - 12" - 20" - 5 @ 9" - 20" - 12" - 16" Oh
 V2 = 20.75" Oh - 13 @ 11.5" - 20.125" - 2 @ 6.5" - 1" Oh

2" PinØ
Bend Tol: ±2.5"

Information provided herein is for quoting of welded wire reinforcement, based on customer information furnished to Insteel. Customer is responsible for confirming that Insteel information quoted is compliant with the project design intent and geometry for the purpose requested. Customer shall review and approve all configurations, sheet styles, and quantities prior to order placement. The Engineer of Record or Governing Authority shall be engaged in the process by the Customer as required to ensure suitability of use.

This drawing was prepared by Insteel and remains the exclusive property of Insteel, subject only to a license to the named customer to use it for the named project, including any required submittals to the Engineer of Record or other governing agencies whose approval is required. This drawing is not to be furnished or distributed to other parties without Insteel's prior written approval.

<p>1373 Boggs Drive Mount Airy, North Carolina 27030 Tel. 800-334-9504</p>	DRAWING TITLE: 36" Set - 4:1	Drawn By: Matthew Smith
	PREPARED FOR: Foley Products	Date: 7 March 2024
	PROJECT: End Wall Forms (30" & 36")	Dwg #: MS-WWR1.4