

4/15/2020 2:44:19 PM P:\StandDraw\DESIGN STANDARDS\Standards Drawings\Standard Roadway Drawings - CURRENT\In Progress\10-104.00 Roadway, Pavement Appurtenances and Fence IP\104.01 Concrete Pavement JP\JP

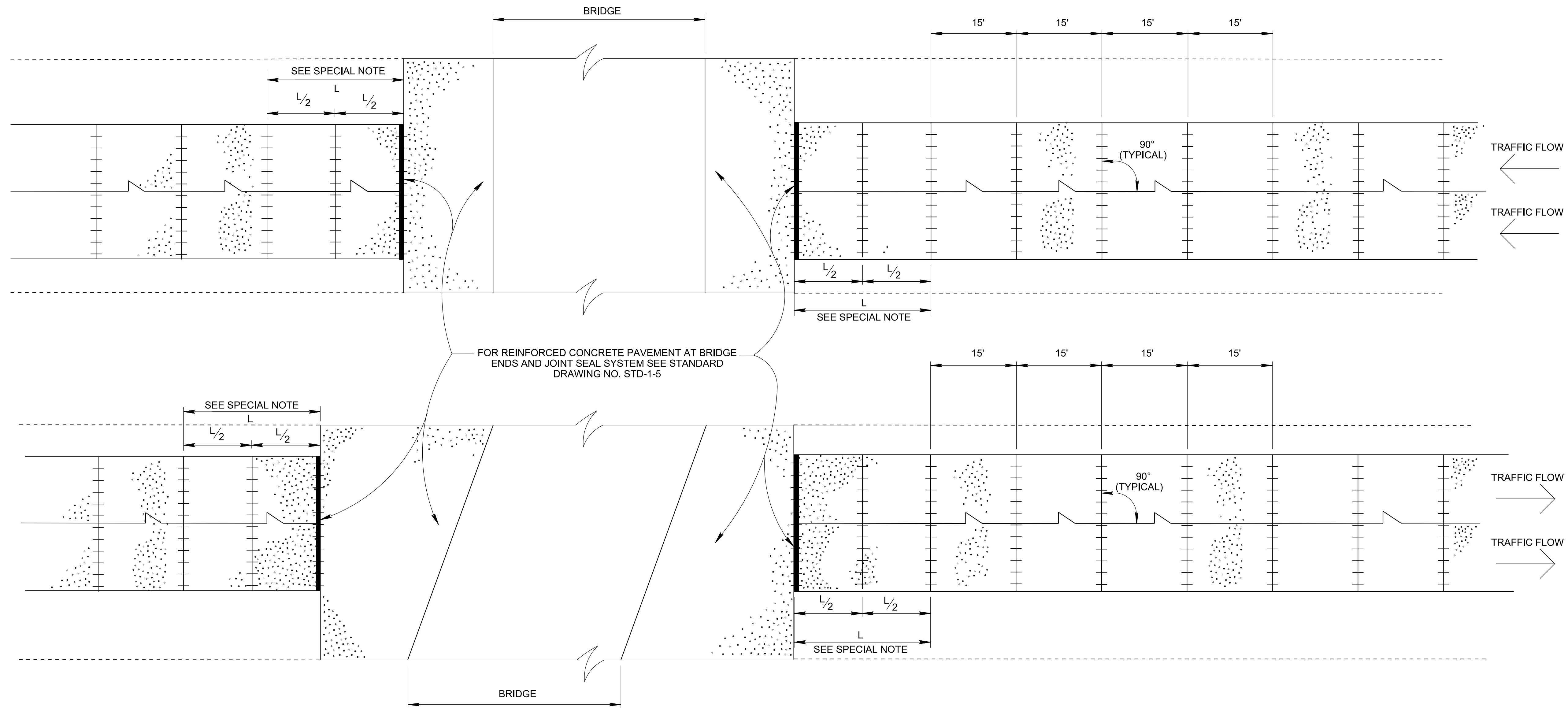

TYPICAL FOUR LANE HIGHWAY

SPECIAL NOTE

THE STANDARD 15 FEET JOINT SPACING MAY BE ADJUSTED TO ACCOMMODATE BRIDGE APPROACH SLABS, AS REQUIRED. THE MINIMUM SLAB LENGTH SHALL BE 8 FEET. THE MAXIMUM SLAB LENGTH SHALL BE 15 FEET.

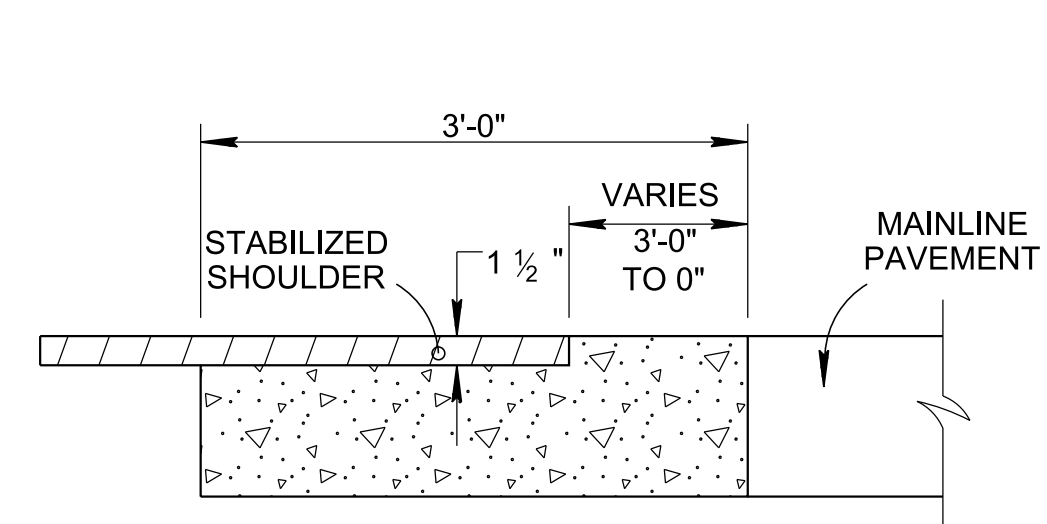

DETAIL A-A

THIS DETAIL IS TO BE USED FOR BOTH ASPHALT AND CONCRETE MAINLINE PAVEMENT.

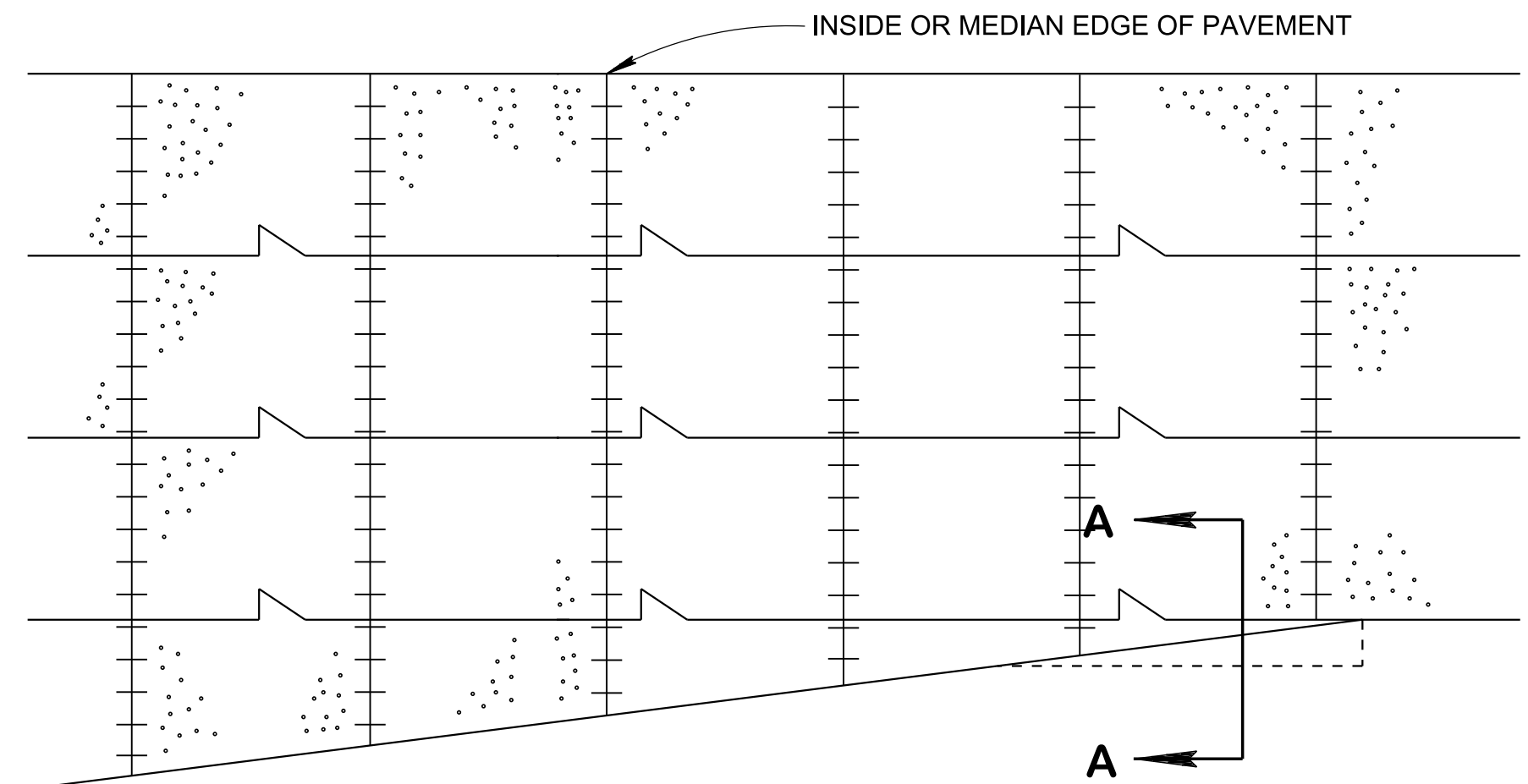

ACCELERATION OR DECELERATION TAPER

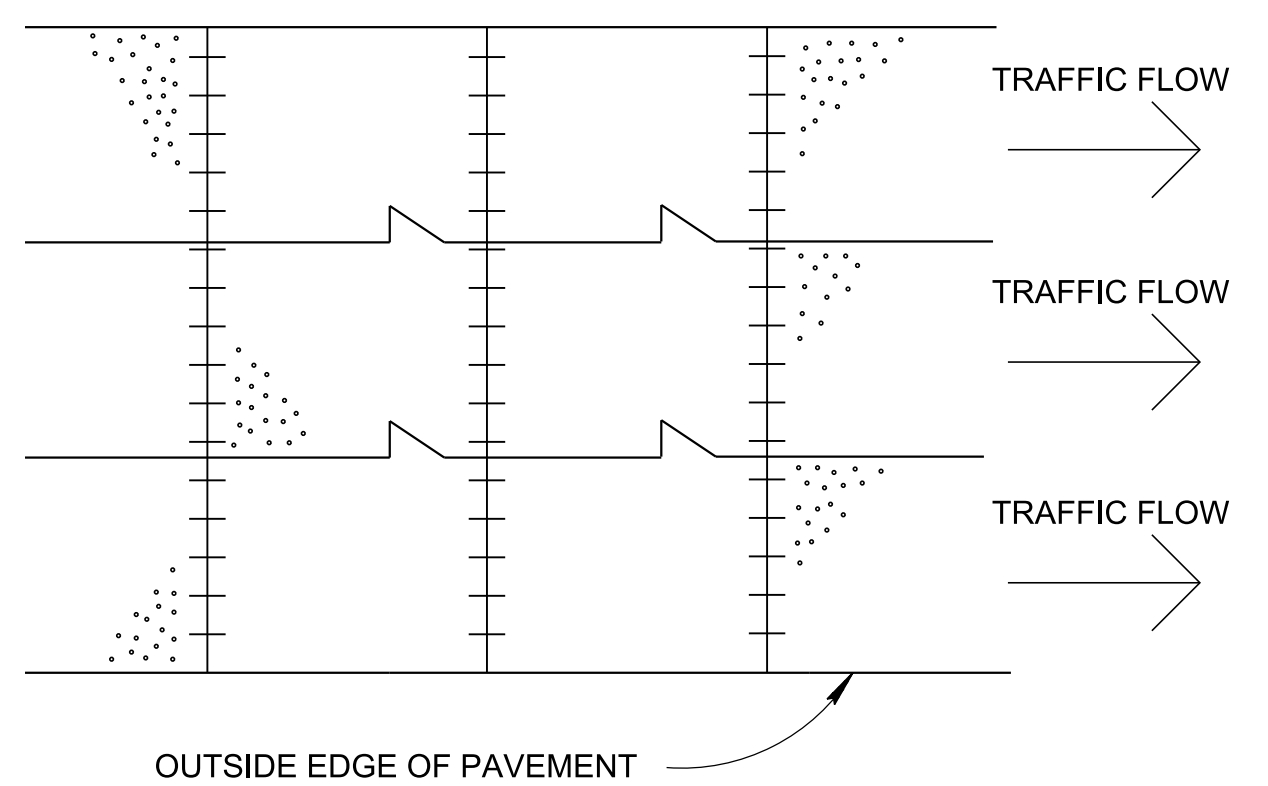

NORMAL THREE LANE PAVEMENT

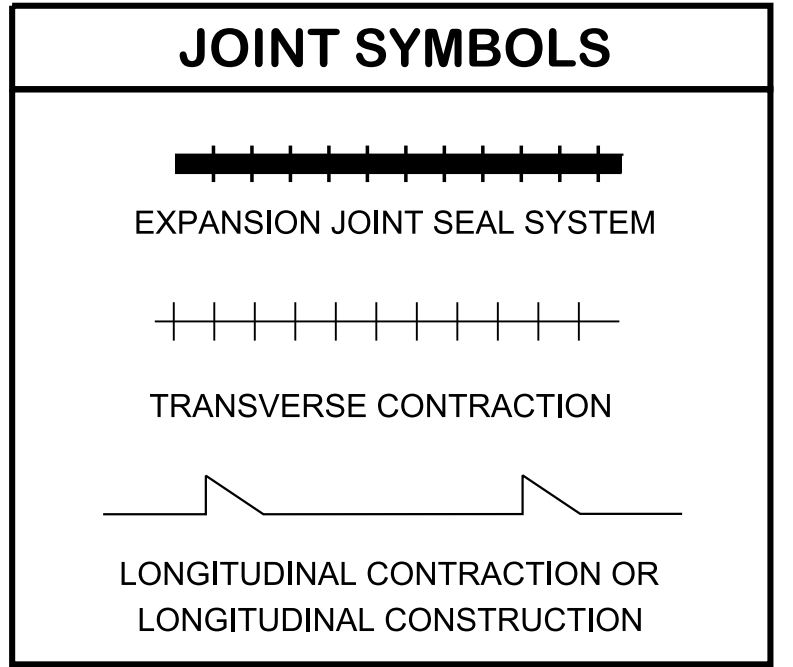

CROSS-REFERENCE DRAWINGS FOR THIS DRAWING: RP-J-9, RP-J-11, RP-J-13, RP-J-15, RP-J-17, RP-J-18, RP-J-19 AND STD-1-5.

APPROVED BY FHWA (ALL OTHERS APPROVED BY TDOT)

STATE OF TENNESSEE
STANDARD DRAWING
DEPARTMENT OF TRANSPORTATION

PORTLAND CEMENT CONCRETE PAVEMENT JOINT TYPES AND SPACING