

ctc technology & energy

engineering & business consulting

The State of the Art and Evolution of Cable Television and Broadband Technology

Prepared for Public Knowledge

November 2014

Columbia Telecommunications Corporation

10613 Concord Street • Kensington, MD 20895 • Tel: 301-933-1488 • Fax: 301-933-3340 • www.ctcnet.us

2. Overview of Cable TV Technology

2.1 Hybrid Fiber-Coaxial Architecture

Cable technology is commonly called “hybrid fiber-coaxial” or HFC. This is because most cable systems consist of fiber connections from the operator’s headend or hub facility (the cable counterpart of the telephone central office) to an optical “node” near the customer premises, and thereafter comprise coaxial cable to the premises.

Cable operators have extended fiber optics progressively closer to their subscribers but have generally stopped at nodes about one mile from the premises. Comcast, for example, typically only constructs fiber optics to the premises of businesses that subscribe to Metro Ethernet and other advanced services (i.e., generally for symmetrical services faster than 50 Mbps).

Advances in HFC networks and technologies and the emergence of fiber-to-the-premises (FTTP) networks are a consequence of the attempts by service providers to deliver high quality, high-bandwidth service offerings to their customers. In many respects, the differences between these networks relate to the geographic scale of their components rather than fundamentally different technologies or approaches to service delivery.

Both HFC and FTTP networks use optical fibers as the primary physical medium to carry communication signals. Additionally, both HFC and FTTP networks leverage some degree of copper or coaxial cabling for connecting devices such as television set-top boxes, computers, routers, and telephones at the customer premises. Both types of networks can carry broadcast analog or digital video signals, provide telephone services with guaranteed availability of network capacity to ensure quality of service (QoS), and deliver Internet and data connections using standards-based Ethernet interfaces to the customers’ equipment.

The most significant distinction between these networks is how closely fiber carries the connection to individual subscribers. A conversion to copper wiring occurs within the “last mile” between a provider and a customer for all HFC networks, while FTTP networks make this conversion at the customer premises.

In the case of an HFC network, headend or hub locations house the core transmission equipment and components necessary for the various service offerings. Fiber optic connections extend from these hubs

to multiple nodes, each of which serves a given geographical area (e.g., a neighborhood). These optical nodes are electronic devices located outdoors, attached to aerial utility lines or placed in pedestals. The equipment in the node converts the optical signals carried on fiber into electronic signals carried over coaxial (coax) cables. From this point onward, coax cable carries the video, data, and telephony services to individual customer locations (Figure 1).

Figure 1: HFC Network Architecture

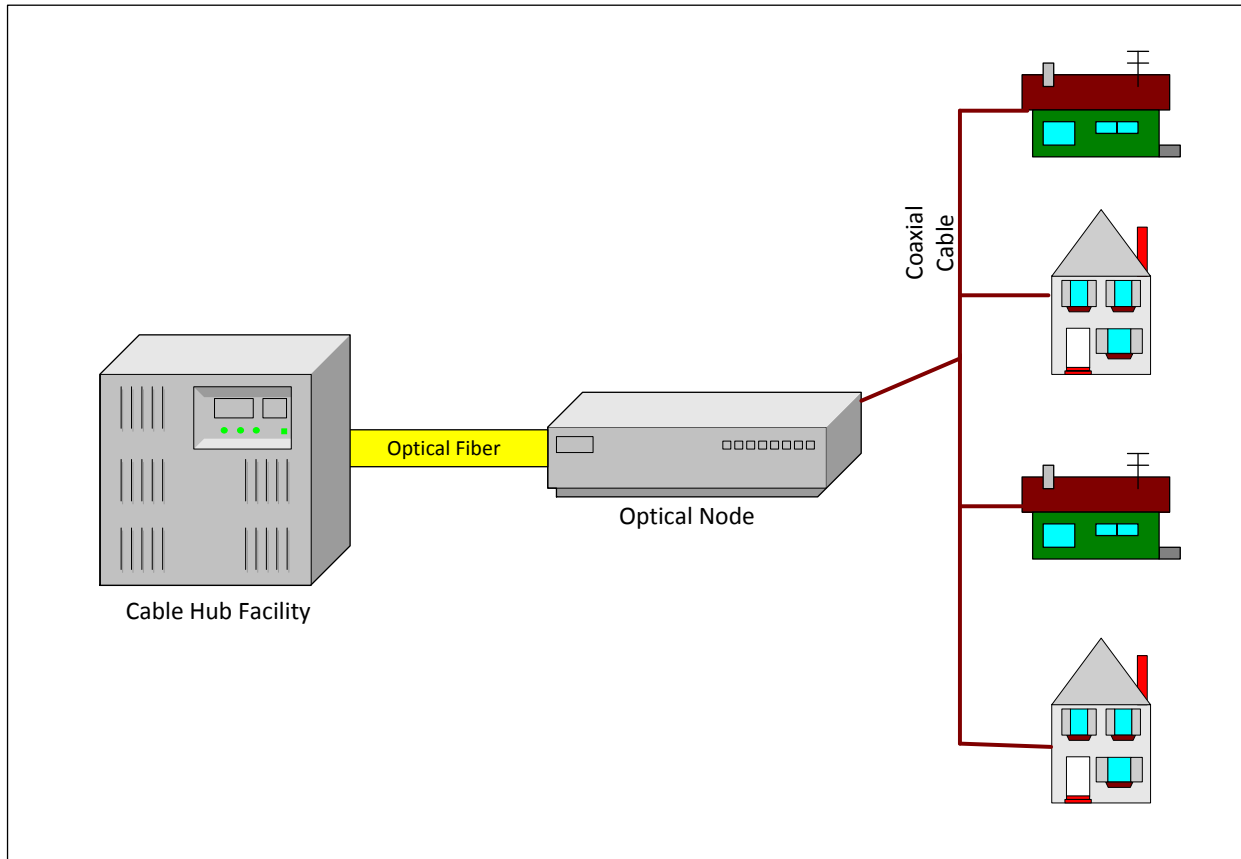

The current leading cable technology for broadband data, known as data over cable service interface specifications version 3.0 (DOCSIS 3.0), makes it possible for cable operators to increase capacity relative to earlier cable technologies by bonding multiple channels together (Figure 2). The DOCSIS 3.0 standard requires that cable modems bond at least four channels, for connection speeds of up to 200 Mbps downstream and 108 Mbps upstream (assuming use of four channels in each direction). A cable operator can carry more capacity by bonding more channels.

It is critical to note that these are peak speeds, and that the capacity is shared by all customers—typically hundreds of homes or businesses—on a particular segment of coaxial cable; this is. Speeds may decrease during bandwidth “rush hours” when more users simultaneously use greater amounts of bandwidth. For example, residential bandwidth use typically goes up considerably during evening hours, when more people use streaming video services and other large data applications.

Figure 2: DOCSIS 3.0 Network Architecture

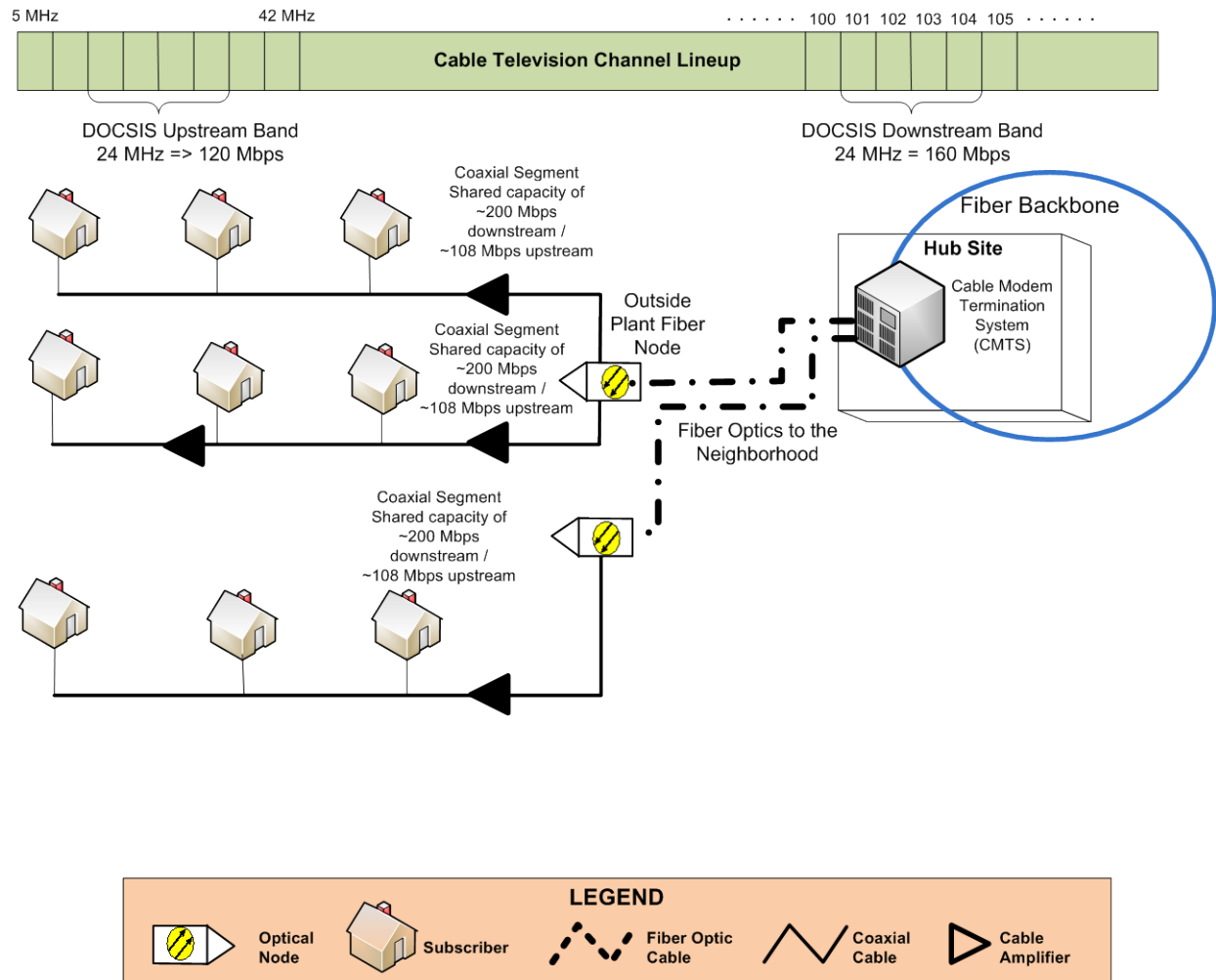

Ultimately, the maximum speed over an HFC network is limited by the physics of the cable plant; the coaxial connection to the customer is generally limited to less than 1 GHz of usable spectrum in total.

2.2 Fiber Optics Form the Backbone of Cable TV Systems

Both coax and twisted-pair copper cables were originally designed to provide video and voice services, and were sufficient in the early years of data communications when usage was low relative to our current expectations. However, as demand for data capacity increased, networks built with these media became insufficient to support high-speed services. On an increasingly large scale, communications carriers and cable operators are deploying fiber to replace large portions of their networks—because for a given expenditure in communications hardware, fiber optics can reliably carry many times more capacity over many times greater distances than any other communications medium.

Fiber is one of the few technologies that can legitimately be referred to as “future-proof,” meaning that it will be able to provide customers with better and faster service offerings to accommodate growing demand.

The biggest advantage that fiber holds is bandwidth. A strand of standard single-mode fiber optic cable has a theoretical physical capacity in excess of 10,000 GHz,⁸ and capacity can be symmetrically allocated between upstream and downstream data flows using off-the-shelf technology. Fiber optics are not subject to outside signal interference and do not require amplifiers to boost signals in a metropolitan area broadband network.⁹

Within a fiber optic strand, an optical communications signal (essentially a ray of light) behaves according to a principle referred to as “Total Internal Reflection” that guides it through the optical cable. Optical cables do not use electrical conduction and thus do not require a metallic conductor, such as copper, as their propagation medium. Unlike electrical signals over copper cables, optical communications signals also do not experience significantly increased losses as a function of higher-frequency transmission.

Further, technological innovations in the development of fiber optics have enabled the manufacturing of very high quality, low impurity glass; these optics can provide extremely low losses within a wide range of frequencies, or wavelengths, of transmitted optical signals, enabling long-range transmissions.

⁸ Conservative estimate derived from the channel widths of the 1285 to 1330 nm and 1525 to 1575 nm bands in G.652 industry-standard single-mode fiber optics.

⁹ Maximum distances depend on specific electronics—6 to 25 miles is typical for fiber optic access networks.

Compared to a signal loss on the order of tens of decibels (dB) over hundreds of feet of coaxial cable, a fiber optic cable can carry a signal of equivalent capacity over several miles with only a few tenths of a dB in signal loss.

Moreover, weather and environmental conditions do not cause fiber optic cables to corrode over time in the way that metallic components can, which means that fiber has lower maintenance costs.

One criticism often directed at fiber networks is the cost involved in constructing and deploying the network. However, while optical fiber is often more expensive per foot than many types of copper wire, the costs including construction have become almost comparable over the past decade. Despite the higher material cost of the fiber, new outside plant construction for copper and optical fiber is generally equivalent, because the vast majority of plant construction cost is due to labor.

3. Cable vs. Other Technologies

3.1 Comparison Between Coaxial Cable and Copper Technologies

Despite the rapid evolution in technologies surrounding telecommunications and computing in the past few decades, the underlying physical media supporting electronic communications within the U.S. are still comprised extensively of copper wiring similar to that used at the turn of the twentieth century. Even the most advanced local area networks (LANs) often use “twisted-pair” copper wire of a design resembling a patent awarded to Alexander Graham Bell in 1881. Notwithstanding tremendous leaps in the capabilities of communications technologies leveraging copper wiring, the fundamental physical properties and limitations of this medium are no different today than when the first telephone exchange was opened in 1877 by the Bell Telephone Company.¹⁰

The history and long life of copper-based communications infrastructure is both a testament to our ability to derive new value from simple concepts through technological innovation, and a warning that copper communications infrastructure has reached a threshold of providing diminishing returns on continued investments.

Due to rising demands for Internet connectivity, cable TV companies and traditional phone companies adapted their infrastructure with new technologies, including cable modems and digital subscriber line (DSL), to begin offering higher-speed data services than simple telephone lines could support.

Bandwidth limits on copper cables are directly related to the underlying physical properties of the medium. Higher data rates require a broader frequency range of operation—wider channels. Twisted-pair wire is limited to a few tens of megahertz in usable bandwidth (at most), with dramatic signal loss increasing with distance at higher frequencies. This physical limitation is why DSL service is only available within a close proximity to the telephone central office.

¹⁰ In-building local area networks (LAN) can carry 100 Mbps and 1000 Mbps (1 Gbps) over copper cables by using two (100 Mbps) or four (1 Gbps) pairs of copper wires (instead of the single pairs used by DSL, U-verse and other services operated by carriers over copper cables in outside plant) and by limiting the maximum distance to 330 feet. LANs also use relatively new cables, while cable outside plant is often the same cabling that was used for telephone service decades ago.

In comparison, coaxial cable has a frequency bandwidth of approximately 1 GHz, approximately 100 times greater than copper cable; therefore its capacity is substantially greater than that of twisted pair. As a result, almost no cable operators are abandoning the HFC architecture—but many telecommunications companies are minimizing their investment in copper lines, and some are abandoning copper lines for wireless services or migrating to FTTP.

The main determinant of DSL speed is the length of the copper line. In systems operated by large telecommunications companies, the average length is 10,000 feet, corresponding to available DSL speeds between 1.5 Mbps and 6 Mbps. In systems operated by small companies in rural areas, the average length is 20,000 feet, corresponding to maximum speeds below 1.5 Mbps.

The fastest copper telephone line technologies in the United States are VDSL and VDSL-2, the technologies underlying AT&T's U-verse and other services. Because these technologies use high frequencies, they are limited to 3,000 feet over typical copper lines and require fiber to the node (FTTN)—much closer than in most HFC systems. Therefore, in order to operate VDSL and VDSL-2, telecommunications companies must invest in large-scale fiber optic construction and install remote cabinets in each neighborhood.

In practice, telephone companies using VDSL-2 over highly upgraded copper lines have been able to provide 25 Mbps over a single copper pair and 45 Mbps over two pairs to the home or business—but it took a significant investment to make it possible for a small percentage of the copper phone lines to temporarily keep pace with cable. Providing even greater speeds will require some combination of even deeper fiber construction, a breakthrough in transmission technology over copper lines, and conditioning and upgrading of the existing copper lines.

The Alcatel-Lucent G.Fast DSL product in development has reached speeds of 500 to 800 Mbps in various environments—but is limited to 330 feet, requiring fiber in front of each home or business.¹¹ Currently, the only widespread transmission of 100+ Mbps speeds over copper lines is local area network (LAN) technology used within residential and business environments. That technology requires

¹¹ Mikael Ricknas, "Alcatel-Lucent gives DSL networks a gigabit boost," *PC World*, July 2, 2013, <http://www.pcworld.com/article/2043483/alcatellucent-gives-dsl-networks-a-gigabit-boost.html> (accessed September 2, 2014).

the use of highly conditioned, new copper (Category 5+ or better), maximum copper distances of 330 feet, and the use of two or four copper pairs for each connection.

3.2 Comparison Between HFC and Fiber-to-the-Premises

As discussed in Section 2.2, HFC and FTTP networks differ in that HFC extends fiber to a node within a mile of the home or business, while FTTP extends fiber all the way to the home or business—typically terminating the fiber at a customer premises device, which then provides service to devices in the home over copper lines, coaxial cable, or wireless connections. As a result, FTTP networks have greater capacity and significant functional benefits over HFC networks. However, HFC can scale in capacity, both through expansion of fiber and upgrading of electronics, and HFC provides a logical evolution path for the hundreds of millions of homes and businesses connected by the technology to gradually reach gigabit speeds.

Because of the properties of fiber optics and the capabilities and scalability of fiber optic electronics, FTTP provides many capabilities that HFC cannot provide. Among current communications technologies, only fiber has the “off-the-shelf” capacity to support gigabit and higher speeds to the majority of users on a network. FTTP is also the only technology with the option of high-speed symmetrical services. At the root of the difference is the superior physical capacity of a fiber optic strand, as compared with coaxial cable. (See Section 2.2 for more details.)

As an example, inexpensive, off-the-shelf equipment used by Google Fiber and other providers can provide symmetrical 1 Gbps service. This is not feasible on an HFC system unless fiber has been extended almost all the way to the subscriber—and even then the service will not be symmetrical. A 1 Gbps cable service will not be a reality until DOCSIS 3.1 is introduced over the next few years, by which time the FTTP state of the art will be 10 Gbps or faster. Therefore, in any ‘greenfield’ setting, or where a telecommunications operator is not leveraging substantial legacy infrastructure, FTTP is the logical choice for a new wired broadband network.

With the cable lengths and components in a typical cable system, coaxial cable is limited to approximately 1 GHz of physical capacity (spectrum), and operators allocate this capacity with roughly 20 times as much downstream (network to user) as upstream (user to network). An additional limitation arises from the shared nature of cable modem service. Because bandwidth within a neighborhood is

shared rather than dedicated, speeds may be significantly decreased by one's neighbors' simultaneous use of their cable modems.

So far, cable operators have found an effective work-around to address the limitations of coaxial cable—a strategy that can help them scale their services for the coming years while they selectively build fiber where demand is highest. This is to use progressively more advanced technologies and protocols over their coaxial cable and to selectively extend fiber backbones deeper into their networks.

The effect of expanding fiber is twofold:

- 1) Extending fiber reduces the number of homes and businesses sharing a segment of coaxial cable, thereby incrementally increasing the available capacity per customer.
- 2) Extending fiber reduces the accumulated effect of the limitations of coaxial cable in the system; with progressively shorter stretches of coaxial cable, the inherent problems with reliability and interference decrease.

For high-value locations (e.g., business parks, “power users,” and secure users such as banks, hospitals, and government), the cable operator may extend fiber all the way to the customer, often alongside the existing coaxial cable (thereby reducing the cost of construction relative to totally “new” construction). By pursuing this strategy, HFC systems can come within range of the capacity of FTTP systems without investing in substantial new cable construction.

Similar to HFC networks, central equipment in an FTTP network is housed at a central office (CO) or video headend office (VHO). From the CO, fiber optics extend directly to each customer premises, often with some type of intermediate device located near the customer to split or aggregate connections, depending on the specific technology chosen. For example, an FTTP network using PON technology would employ a passive optical splitter between the CO and the customer locations. The role of the splitter is to simply “split” the signal from the CO into individual customer signals, typically supporting either 32 or 64 customers per fiber strand (Figure 3).

Figure 3: FTTP-PON Network Architecture

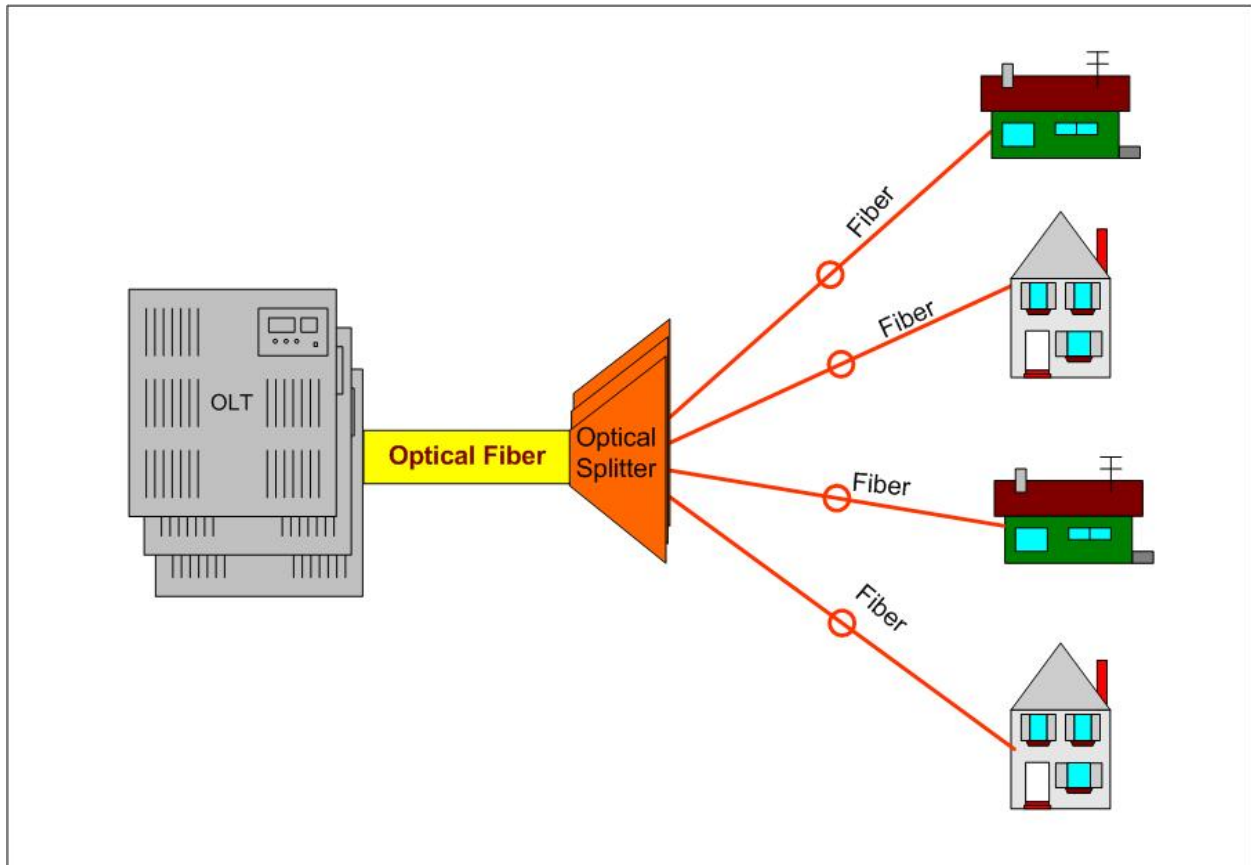

3.3 Comparison Between Cable and Wireless Technology

Mobile and wireless broadband consumption has skyrocketed since the introduction of iPhones, Android devices, and tablets starting in 2007. Consumers now expect robust and ubiquitous wireless connectivity. Increasingly, the connection to individual customers' devices is wireless—either a Wi-Fi connection to a wired HFC, DSL, or fiber network, or a direct connection to a commercial mobile broadband network.

No matter the type of wireless technology, the quality of wireless connections is affected by several factors, such as:

- The over-the-air radio frequencies or spectrum utilized
- The user's proximity to a transmission tower or antenna
- Physical barriers such as buildings, trees, or terrain

- Challenges in providing wireless services indoors, especially inside large buildings, in basements, and in underground garages
- Weather
- The type of wireline or “backhaul” connection at the tower or router (i.e., whether it is connected to a DSL, point-to-point wireless, or fiber optic service—and the speed of that connection)

The variable nature of all of these factors means that wireless performance can be unpredictable. High speeds are possible, but only if environmental and other conditions allow. It is also important to note that wireless networks are largely composed of wireline technology. For example, when a user accesses the Internet on a smartphone, the initial connection is from the device wirelessly to the provider’s nearest tower. But all subsequent data transmission from the antenna onward through the network likely occurs via wireline copper or fiber networks. Similarly, in a residence or in a local Wi-Fi deployment by a cable or wireless provider, a Wi-Fi router provides wireless flexibility and allows multiple users to connect to the underlying DSL, cable, or fiber broadband connection.

Wireless technologies provide flexible, convenient, and mobile communication, but have tradeoffs with respect to data capacity and reliability. While the speed of mobile and wireless technologies is constantly improving, under most scenarios these technologies are not capable of supporting applications for telehealth, interactive distance learning, or high-definition “virtual presence” video conferencing, all of which require very large amounts of bandwidth and reliable connections.

3.3.1 Mobile 3G/4G Technology

3G and 4G are terms used to describe a cellular provider’s different mobile broadband offerings. However, 3G and 4G stand for “third-” or “fourth- generation” of mobile broadband and do not refer to specific mobile technologies. The term 4G was originally intended to designate wireless services with 1 Gbps capability, but is now mostly a marketing term that encompasses a number of different mobile technologies. In practice, 4G refers to mobile technologies such as Evolved High Speed Packet Access (HSPA+), WiMAX, and Long-Term Evolution Release 8 (LTE).

The greatest advantage of 3G/4G services is mobility. Users’ basic feature phones, smartphones, and other mobile devices connect to a series of antennas and base stations that are attached to cell phone towers or, in more urban settings, located on tall buildings. If placed on a mountain top or high tower

with minimal line-of-sight restrictions, the antennas have a transmission distance of more than 40 miles. However, wireless networks are more typically designed with coverage and data capacity, not point-to-point distance, as the main goals. Therefore, the transmission radius for most 3G/4G towers is less than a few miles. The smaller radius is intended to ensure adequate bandwidth for all customers accessing that tower, avoid scenarios in which too many individuals are competing for limited capacity, and provide the capability for users to simultaneously connect to more than one antenna.

As is the case with all wireless technologies, the main limitation on 3G/4G networks is the variability of connection quality and speeds. Typical 3G technologies have maximum download speeds of 1 to 2 Mbps and upload speeds of less than 1 Mbps. Typical 4G technologies have theoretical maximum download speeds from 42 Mbps to 100 Mbps and upload speeds from 11.5 Mbps to 50 Mbps. The speeds users actually experience, however, may be significantly lower due to environmental factors or a large number of devices sharing access at a tower.

Even when a 3G/4G network is designed with a small cell radius to decrease the number of subscribers covered by each cell, the number of user devices simultaneously trying to communicate with the antenna can still cause congestion. Likewise, the technology used to connect the wireless antenna to the rest of the network, whether copper or fiber optic cable, can influence the actual data speeds available to users. Recent testing has shown that typical 4G speeds are usually 4 Mbps to 13 Mbps download and 2 Mbps to 6 Mbps upload.

3G/4G networks are most limited with regard to upload speeds. This limitation is a byproduct of the technology itself. Upload speeds will always be slower than download speeds given that 3G/4G wireless antennas are point-to-multipoint, meaning that a single antenna broadcasts a signal to and receives signals from many devices. This approach makes it simpler for transmission to go downstream to cellular users, from the single point out to the many devices. It is more difficult to manage incoming traffic from multiple devices to the single antenna, as is the case when users send data. In addition, power and battery limitations mean that the signal strength of transmissions from smartphones or other end-user devices is significantly weaker than signals from the tower, further limiting upload speeds unless a user is very close to a tower. Thus, 3G/4G networks will be optimized to deliver significantly faster download speeds than upload speeds.

The asymmetrical service of 3G/4G networks limits the types of applications they can sustain, such as high-definition video conferencing applications or large-scale online file backup services that require

access to higher upload speeds. Furthermore, even where wireless capacity exists for video and other bandwidth-demanding services, wireless service providers typically charge for usage, limiting how much capacity and what applications can be affordably used.

Table 1: Download/Upload Speeds of Wireless Technologies

Applications	Technology (Download/Upload Service Speeds) ¹²		
	2G/2.5G–EDGE/GPRS, 1xRTT (50 Kbps–300 Kbps / 20 Kbps–100 Kbps)	3G–EVDO Rev A, HSPA+ (600 Kbps–1.5 Mbps / 500 Kbps–1.2 Mbps)	4G – LTE (1.5 Mbps–6 Mbps / 500 Kbps–1.2 Mbps)
Simple text e-mails without attachments (50 KB)	Bad to Good (2 to 40 seconds)	Good (1 second)	Good (1 second)
Web browsing	Bad to Good	Good	Good
E-mail with large attachments (500 KB)	Bad to OK (14 to 200 seconds)	Good (3 seconds)	Good (1 second)
Play MP3 music files (5 MB)	Bad (134 to 2000 seconds)	OK (27 seconds)	Good (7 seconds)
Play video files (100 MB for a typical 10-min. YouTube video)	Bad (45+ minutes)	OK (9 minutes)	Good (3 minutes)
Maps and GPS for smartphones	Bad	OK	Good
Internet for home	Bad	OK	Good

A 3G/4G service provider can typically enter a new area more quickly than a wired service provider. It can add capacity or coverage by adding base stations and antennas, typically without directly causing a high impact on miles of public rights-of-way. However, there are significant challenges in providing effective wireless service. Design limitations such as power levels, spectrum availability, and required data capacity mean that individual antennas or base stations serve limited areas, often one mile or less. This requires the provider to expend resources and time in placing more base stations.

¹² These data assume a single user. For downloading small files up to 50 KB, it assumes that less than 5 seconds is good, 5-10 seconds is OK, and more than 10 seconds is bad. For downloading large files up to 500 KB, it assumes that less than 5 seconds is good, 5-15 seconds is OK, and more than 25 seconds is bad. For playing music, it assumes that less than 30 seconds is good, 30-60 seconds is OK, and more than 100 seconds is bad. For playing videos, it assumes that less than 5 minutes is good, 5-15 minutes is OK, and more than 15 minutes is bad.

In order for the network to be effective, each base station requires power, backup power (such as generators and batteries), a tall structure for mounting the antennas, coordination with other wireless providers for interference, aesthetic compatibility with the surroundings, connections to the Internet and core network, and security. The provider must address the concerns of the community and the zoning authorities, and must typically pay significant rental fees. Every time the provider desires to improve coverage quality or add capacity, it must face these challenges in placing new facilities.

In addition, to serve customers who are indoors, providers must increase the density of their base stations or add facilities such as microcells or picocells inside buildings.

The challenge of deploying and managing a wireless network may be greater if an unlicensed technology such as Wi-Fi (Section 3.3.2) is used. While the provider does not need to obtain a Federal Communications Commission (FCC) license, it must operate lower-power equipment in accordance with FCC requirements. This requires the use of significantly greater densities of antennas, typically one for each street block. In addition to the challenge of placing and powering the devices, the service provider must accept and cope with all existing and potential future interference from other users of the unlicensed frequency band. It must have a technique to ensure that sufficient data bandwidth is available at the many antenna points and to address the unique capacity and interference problems at each antenna site.

Finally, when a provider needs to migrate to a more advanced technology platform, it may need to re-engineer and redesign its entire system. Antennas, receivers, and transmitters may become obsolete, and spacing between base stations may need to be changed. Power and backbone connectivity may need to be upgraded. A thorough wireless upgrade, as may be required a few times per decade, may require the provider to replace a significant percentage of its capital investment.

3.3.2 Fixed Wireless Carrier Technology

Wireless carriers such as AT&T, Verizon, Sprint, and T-Mobile offer fixed 3G/4G-based wireless Internet services for residential and small business customers across the nation. These services involve the purchase¹³ or rental of customer premises equipment (CPE) that connects to the carrier's 3G/4G

¹³ The average CPE purchase cost among the national carriers is \$175.

network. The CPE then acts as a Wi-Fi hotspot or Ethernet switch for customer devices to connect to the Internet, similar to a cable or DSL modem.

The CPE typically utilizes the same LTE or 3G mobile network as cellphones, but is optimized to provide better reception through the use of enhanced antenna techniques such as multiple input, multiple output (MIMO) and higher gains—which can translate to higher speeds during actual use. The CPE can either be a professionally installed, fixed unit or a portable unit that can be moved to different locations by the customer.

The carriers offer fixed wireless service with maximum download speeds between 5 Mbps and 12 Mbps and maximum upload speeds between 2 Mbps and 5 Mbps. However, customers must adhere to strict limits on their data usage or face high charges for overages.

The CPE may also provide voice services through standard voice jacks. At this stage, the voice service is carried by the wireless carrier on its 2G frequencies, using the same technology as the standard cellular voice service. Like the cellular voice services, this is expected to migrate to an IP service over the LTE network.

Because of their relatively high cost and low capacity, compared to cable, these services are best suited for scenarios in which other connectivity options are unavailable—in rural or remote areas, for example. Fixed carrier wireless is also relatively more desirable if a user frequently moves between fixed locations, such as for work, in college environments, or at a vacation home that is only used for part of the year.

The various fixed wireless service offerings¹⁴ are not cost-effective compared to cable or fiber-based services that do not assign such low data limits. It is interesting to note that carriers like Verizon and AT&T initially positioned their fixed wireless services as an alternative in areas where they did not provide wired services. However, due to the inherent limitations in the availability of wireless spectrum and the design principles of wireless carriers—which cater to mobile users who have less intensive data

¹⁴ The national carriers offer fixed wireless data plans ranging from \$20 per month for 500 MB of data to \$120 per month for 30 GB of data. There are also equipment charges (with or without a contract) and activation fees. Overage charges are additional and range from \$10 to \$50 per GB.

needs—it is unlikely that the value proposition offered by fixed wireless services will lead it to replace wired services in the near future.

The implementation of new technologies such as LTE-Advanced and beyond, which promise much higher speeds (up to 1 Gbps), has the potential to increase individual user speeds in excess of 100 Mbps. However, although this exceeds what is available from DSL services, it is still significantly less than what is projected in the same period for fiber and cable technologies.

3.3.3 Wi-Fi Technology

Wi-Fi is a wireless networking standard known as 802.11 developed by the Institute of Electrical and Electronics Engineers (IEEE). Wi-Fi currently operates in the United States within the 2.4 GHz and 5 GHz frequency bands allocated by the FCC for unlicensed use. This designation means that individual users do not require a license from the FCC; the public can purchase Wi-Fi equipment approved by the FCC and operate it freely. This is different than 3G/4G networks that have equipment designed to operate only on the frequencies where a mobile operator has a license (which the operators typically purchase through an auction carried out by the FCC).

Wi-Fi routers have become commonplace in households, offices, coffee shops, airports, and public spaces. They have also been deployed by Comcast and other wired providers to sell Internet service to individuals in those public spaces.

There are several advantages to operating on unlicensed spectrum. With worldwide access to those frequencies, manufacturers of Wi-Fi equipment can take advantage of significant economies of scale, as equipment does not need to be designed for a single operator or licensee. As a result, Wi-Fi equipment is substantially less expensive than 3G/4G technology.

In addition, Wi-Fi has access to larger and more contiguous frequencies compared to most licensed frequencies, which are broken into smaller and more discrete sections in order to allow multiple operators to obtain exclusive licenses. The shared common pool of frequencies in the 2.4 GHz and 5 GHz bands allows Wi-Fi devices to operate on wider channels to increase capacity and speeds. As a result, Wi-Fi technologies are able to operate at high speeds, often faster than the wireline services provided by cable operators. Most Wi-Fi equipment offers maximum download and upload speeds between 50 and 100 Mbps, and updates to the 802.11ac standard could allow for maximum speeds up to 500 Mbps—comparable to the highest speeds being considered for HFC.

The drawback of operating on unlicensed spectrum is that Wi-Fi devices must coexist with other Wi-Fi devices in the band, as well as with other unrelated consumer devices. For example, in the 2.4 GHz band, Wi-Fi devices share spectrum with garage door openers, TV remote controls, and microwave ovens. These devices create interference in the band that can inhibit the performance of Wi-Fi connections. The density of other Wi-Fi devices in the area can also have an impact. The Wi-Fi standard has a built-in contention protocol to manage this issue; Wi-Fi devices are designed to detect other Wi-Fi devices and not broadcast at the same time. However, too many Wi-Fi radios operating in a small area and all on the same frequencies can cause significant performance degradation.

The FCC also regulates the operation of devices within the unlicensed bands used by Wi-Fi, including limitations on devices' transmission power in order to accommodate more devices and users in the band. Thus, Wi-Fi networks have limited range compared to 3G/4G networks. High-end Wi-Fi routers have a range of around 800 feet, or approximately one to two city blocks. Typical consumer-grade Wi-Fi devices only serve a single residence. These devices are called "omnidirectional" in that they broadcast their signal equally in all directions. (Directional Wi-Fi antennas that broadcast their signal in a focused path toward a single business or home can have a range of two to four miles, depending on environmental conditions.) Further limiting the range is the fact that Wi-Fi utilizes higher-frequency spectrum; those signals cannot penetrate walls and foliage or travel as far as signals operating at lower frequencies.

Wi-Fi was designed as a wireless local area networking solution, and is therefore ideal for supporting and sharing connectivity over a small area such as a home, office, campus, or public park. It is largely a complementary technology to a wireline connection; thus, the speeds provided by Wi-Fi connections are usually a reflection of the speeds of the underlying DSL, cable, or fiber optic connection to the Wi-Fi router. Over small areas and with a small number of users, Wi-Fi networks can support most widely available Internet applications including higher-bandwidth streaming video or video conferencing. However, as one expands the coverage area and adds more users, a Wi-Fi network's ability to support higher-bandwidth uses diminishes and it offers connectivity and speeds similar to 3G/4G service.

3.3.4 Wireless Performance Is Physically Limited by Scarce and Costly Electromagnetic Spectrum

All wireless devices use the electromagnetic spectrum. The spectrum is shared by a wide range of users and devices. Most of the spectrum is assigned to particular uses by the FCC and by international

agreement (Figure 4). Commercial licensed spectrum bands for voice and broadband services include 700 and 800 MHz, and 1.7, 1.9, 2.1, 2.5, and 3.5 GHz. Popular unlicensed bands include 900 MHz, 2.4 GHz, and 5.8 GHz.

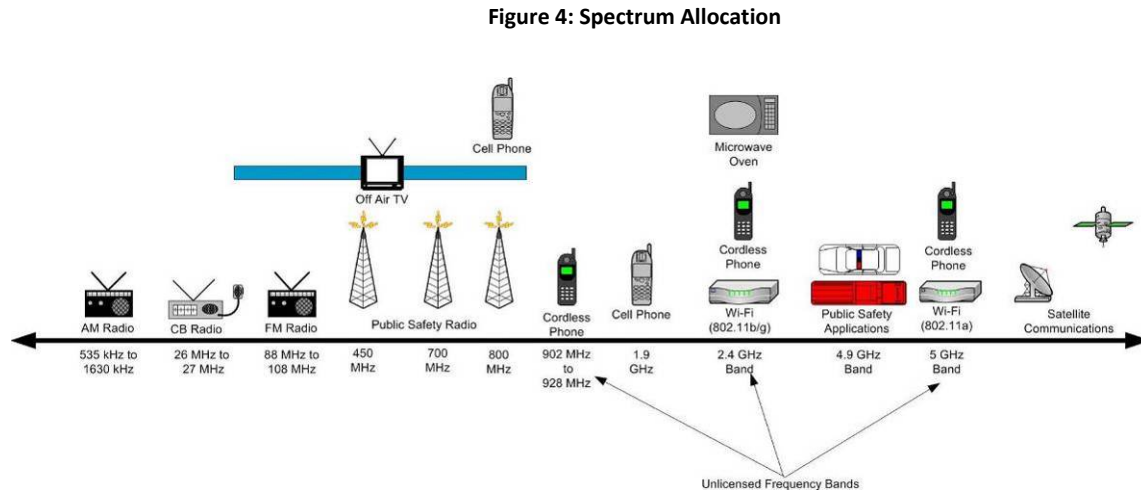

Higher-speed services typically use the higher-frequency spectrum. The higher-frequency spectrum typically has broader channel widths and therefore is capable of providing more capacity. Lower-frequency spectrum typically only has smaller channels available, but has the advantage of penetrating buildings and materials and not requiring as much of a direct line of sight.

Examples of wide channel widths are tens of MHz available in the Advanced Wireless Spectrum and former “Wireless Cable” spectrum. The actual capacity (speed) available will vary according to specific conditions and the technology used, but a reasonable estimate is that the maximum available speed from current technology is within an order of magnitude of the spectral width of a channel. Therefore, tens of MHz of spectrum in a particular large communications channel can theoretically provide the wireless users in a particular area with hundreds of megabits per second of aggregate capacity.

The available speed can be increased by narrowing the wireless beam to smaller areas, and even particular users. Technologies can exploit multiple simultaneous paths between the two endpoints of communications. They can transmit in multiple senses of polarization. They can use sophisticated coding techniques to maximize spectral efficiency.

More spectrum will be opened up to unlicensed “secondary” broadband use through access to unused television channels (also known as TV “white spaces” or TVWS). TVWS technology is in its initial deployments and operates at speeds up to a few Mbps, but can be expected to become cheaper and

faster as it develops and becomes standardized. Also, a new generation of ultrawideband wireless technology uses very large channels at high frequencies, but must operate at low power to not interfere with other users—which limits the technology to short-range or point-to-point use.

Nonetheless, even if the entire electromagnetic spectrum were to somehow simultaneously become available for particular wireless users, *the laws of physics dictate that this theoretical wireless capacity would still be less than the terabits per second (Tbps) currently available in one fiber optic cable with existing off-the-shelf technology.*

The same general comparison holds true for the capacity of an HFC network, which makes 1 GHz available over each node segment (i.e., up to a few hundred homes). Although this capacity is less than over fiber, it is still several times greater than all commercial wireless spectrum combined. In other words, even if a single entity were able to aggregate all available commercial spectrum and focus its antenna beams on a neighborhood with a few hundred homes, it would still have only a fraction of the capacity currently available to the local cable provider. And it would still be subject to all the wireless technical limitations discussed above—including the need for wired capacity (usually fiber optic capacity) to connect the wireless communication system to its core and to other networks.¹⁵

3.3.5 Both Wireless and HFC Wireline Technologies Can Scale but Wireline Technologies Always Hold a Capacity Advantage

Communications equipment is big business, and researchers and manufacturers are constantly improving both wireless and fiber technologies. As a result, both can be expected to grow in their capability to offer more speed and capacity. However, while it is likely that broadband wireless technology will provide sufficient bidirectional capacity for many additional applications in future years, the capacity of a service over a single pair of fiber optics has consistently been five to 50 times the capacity of comparable carrier-provided wireless links and services over the past 10 years.

For example, off-the-shelf CDMA wireless technologies provides typical speeds of a few Mbps—at a time when typical fiber connectivity supports 10 to 100 Mbps Metro Ethernet technologies. Now, the cutting

¹⁵ Additionally, it would need to depend on a wired service provider, such as a fiber optic company or cable operator, to connect its antenna back to the Internet and backbone network.

edge of carrier wireless solution is LTE networking with peak speeds around 20 Mbps—while cutting-edge fiber service is symmetrical 1 Gbps service.

This gap will likely remain. In coming years, we anticipate the development of advanced wireless technologies, including adaptive antennas,¹⁶ using multiple simultaneous wireless transmission routes, advance spectrum reuse techniques, and point-to-point laser optical technologies. At the same time, HFC cable and fiber optic advances will likely include faster electronics, a wider range of wavelengths, and optical switching.

Figure 5 provides examples of broadband wireless and wireline technologies, including licensed, unlicensed, private, and carrier technologies. Because the actual capacity available to a user will vary according to specific circumstances, the capacity is shown as a range for each technology.

Figure 5: Wireless and Wireline Capacity

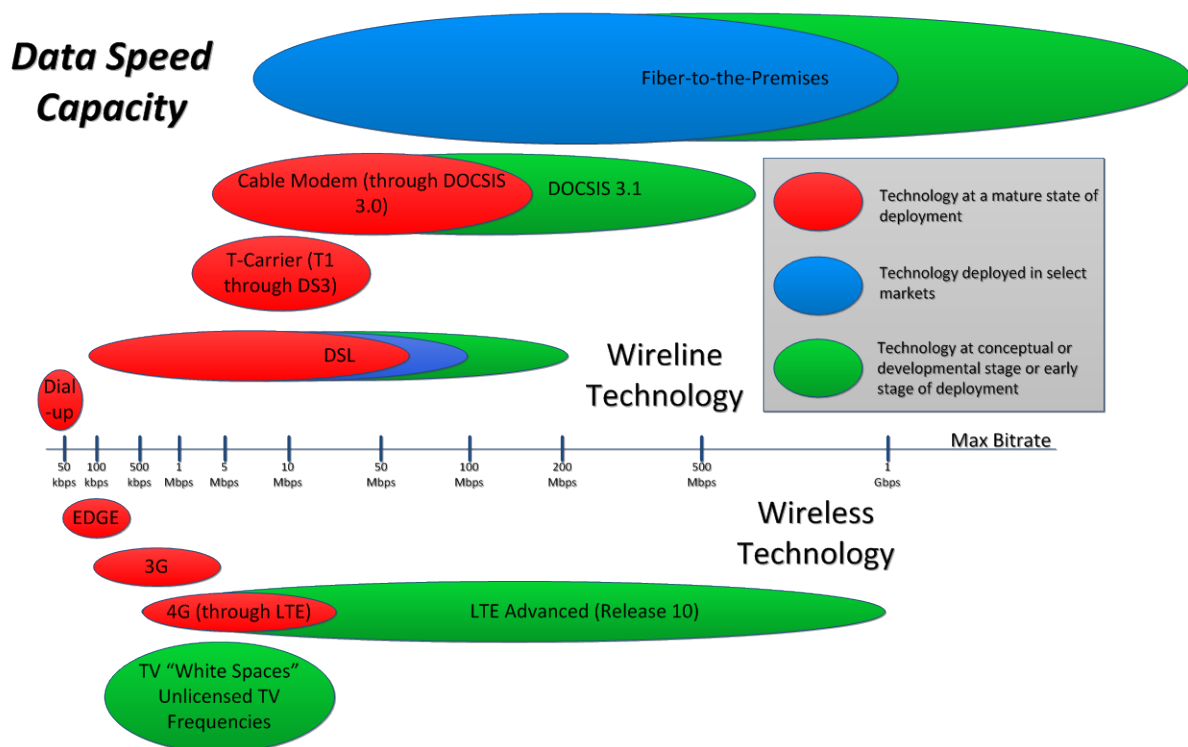

¹⁶ Including multiple input multiple output (MIMO) antennas