

# Distribution Systems

## Course #501



Department of  
**Environment &  
Conservation**



## Table of Contents

Section 1	Overview	1
Section 2	System Design & Pipes	13
Section 3	Valves	43
Section 4	Water Stability	53
Section 5	Storage Tanks	63
Section 6	Disinfection	77
Section 7	Hydrants	95
Section 8	Water Services & Meters	125
Section 9	Cross Connection Control	145
Section 10	Safety & Trenching	167
Section 11	Pumps & Equipment Maintenance	199
Section 12	Sampling & Water Analysis	227
Section 13	Regulations & Design Criteria	239
Section 14	Sacramento & AWWA Review Questions	305



# **Section 1**

## **Overview**

## Common Abbreviations

ASTM – America Society for Testing and Materials	NTU – Nephelometric Turbidity Units
ANSI – America National Standards Institute	OSHA – Occupational Safety and Health Act
AWWA – America Water Works Association	P-A – Presence-Absence
AVB – Atmospheric Vacuum Breaker	PN – Public Notification
CCR – Consumer Confidence Report	PPE – Personal Protective Equipment
CWS – Community Water System	PPM – Parts Per Million; mg/L
DCVA – Double Check Valve Assembly	PSI – Pounds per Square Inch
DBP – Disinfection Byproduct	PVB – Pressure Vacuum Breaker
DO – Dissolved Oxygen	PWS – Public Water System
DWR – Division of Water Resources	RPBP – Reduced Pressure Backflow Prevention
EPA – Environmental Protection Agency	RTCR – Revised Total Coliform Rule
GAC – Granular Activated Carbon	SCBA – Self-Contained Breathing Apparatus
HAA <sub>5</sub> – Haloacetic Acids	SDS – Safety Data Sheets
HPC – Heterotrophic Plate Count	SDWA – Safe Drinking Water Act
HTH – High-Test Hypochlorite; Calcium Hypochlorite	sMCL – Secondary Maximum Contaminant Level
LCRR – Lead and Copper Rule Revised	SOC – synthetic organic carbon
MCL – Maximum Contaminant Level	SOP – Standard Operating Procedures
MGD – Million Gallons per Day	TDEC – Tennessee Department of Environment & Conservation
MRDL – Maximum Residual Disinfection Level	TDS – Total Dissolved Solids
NCWS – Non-Community Water System	THM – Trihalomethane
NOM – Natural Organic Material	TTHM – Total Trihalomethane
NPDWR – National Primary Drinking Water Regulation	TOC – Total Organic Carbon
NSF – National Sanitation Foundation	TNCWS – Transient Non-Community Water System
NTNCWS – Non-Transient Non-Community Water System	VOC – Volatile Organic Chemical

## Suggested Distribution System Exam References

- The following are approved as reference sources for the ABC distribution examinations. Operators should use the latest edition of these reference sources to prepare for the exam.

### Textbooks

American Water Works Association (AWWA) ([www.awwa.org](http://www.awwa.org))

- Water Transmission and Distribution
- Water Distribution Operator Training Handbook
- Basic Science Concepts and Applications
- Water System Security, A Field Guide
- Water Quality
- AWWA Standard for Installation of Ductile-Iron Water Mains and Their Appurtenances (ANSI/AWWA C600-93),

Association of State Drinking Water Administrators (ASDWA) and National Rural Water Association (NRWA)  
[www.asdwa.org](http://www.asdwa.org)

- Security Vulnerability Self Assessment Guide for Small Drinking Water Systems

California State University, Sacramento (CSUS) Foundation, Office of Water Programs ([www.owp.csus.edu](http://www.owp.csus.edu))

- Water Distribution System Operation and Maintenance
- Small Water System Operation and Maintenance
- Manage for Success

### Regulations

- Code of Federal Regulations, Labor (CFR 29), Part 1926 ([www.gpo.gov](http://www.gpo.gov))
- Code of Federal Regulations, Title 40 Part 141, [www.gpo.gov](http://www.gpo.gov))
- Community Public Water Systems Design Criteria, State of Tennessee, Department of Environment and Conservation, Division of Water Resources, Nashville, Latest Revision.

Regulations for Public Water Systems and Drinking Water Quality, State of Tennessee, Department of Environment and Conservation, Division of Water Resources, Nashville. TN, **0400-45-01** Latest Revision.

- Rules Governing Water and Wastewater Operator Certification, State of Tennessee, Department of Environment and Conservation, Board of Certification for Water and Wastewater Operators, Nashville, TN Latest Revision, Section 400-49-01.
- State of Tennessee Cross-Connection Control Manual, State of Tennessee, Department of Environment and Conservation, Division of Water Supply, Nashville, Latest Revision.
- Water and Wastewater Operator Certification Act, T.C.A. Section 68-221-901. T.C.A. Section 68-221-915.

### Study Guides

American Water Works Association: Operator Certification Study Guide, Fifth Edition: A Guide to Preparing for Water Treatment and Distribution Operator Certification Exams.

## Grade 2 Distribution Systems Operator Need-To-Know Criteria (Subject Areas)

The following list of categories suggests topics of information that are important to know in order to be a successful and proficient Grade 2 Distribution Systems Operator. The list may not be all-inclusive, and knowledge of additional topics may be of benefit.

### *Category of Information: Processes*

#### Conveyance

- Piping
- Valves
- Hydrants
  - Parts
  - Flushing
- Service Connections

#### Pressure Control

- Booster Pumps
- Regulators & Gauges

#### Storage

- Ground Tanks
- Elevated Tanks
- Standpipes
- Hydropneumatic Pressure Tanks

#### Metering

- Displacement
- Velocity
- Differential Pressure

#### Leak Detection and Repair

- Sonic Devices
- Pressure Devices
- Volume
- Visual

#### Disinfection

- Tanks
- Lines

#### Cross Connections

- Air Gap
- Reduced Pressure Principle Assembly
- Double Check Valve Assembly
- Vacuum Breakers
- Backflow
- Backpressure
- Backsiphonage
- Cross Connection

### *Category of Information: Support Systems*

#### Motors

- Single Phase
- Three-Phase
- Variable Speed

#### Drives

- Coupled
- Direct

#### Pumps

- Centrifugal
- Positive Displacement (Piston Plunger; Diaphragm)
- Turbine
- Metering

#### Generators

- AC

#### Pipes

- Ductile Iron
- PVC
- Asbestos Cement

#### Joints

- Flanged
- Compression/Dresser
- Gas
- Threaded

#### Valves

- Ball
- Check
- Globe
- Gate
- Pressure Control
- Vacuum Relief
- Butterfly
- Air Release
- Foot (on pump at intake)
- Altitude

#### Fittings

- Coupling
- Union
- Plug/Caps
- Corporation
- Curb Stop



### **Category of Information: Support Systems (continued)**

#### Measuring and Control

- Signal Generators
  - Magnetic Flowmeter
  - Venturi
  - Propeller Meter
  - Ultrasonic
  - Pitot tube
- Signal Transmitters
  - Electric
  - Pneumatic
  - Mechanical
  - Telemetry
- Signal Receivers
  - Counters
  - Indicators
  - Totalizers
  - Recorder
- Meters
  - Electrical – Amp
  - Electrical – Watt
  - Electrical - Multi – VOM
  - Electrical - Multi – MA
- Alarms
- Controls
  - Pneumatic
  - Float
  - Hydraulic
  - Electrical
  - Telemetry
  - Timers

#### Cathodic Protection Devices

- Anode Rod/Bags
- Cathode Rod/Bags
- Rectifiers
- Galvanic Corrosion
- Dissimilar Metals

#### Chemical Feeders

- Booster Chlorinator
- Hypochlorinators
- Gas

#### Rolling Stock

- Service Vehicles
- Trucks
- Tractors
- Trailers
- Lawn Mowers
- Loaders
- Portable Pumps
- Generators

#### Safety

- Personal Protection Gear
- Traffic Control (Warning Devices; Barricades)
- Hazard Detection
- First Aid/Hygiene
- Confined Space
- MSDS Information

#### Security

- Attack
  - Prevention
  - Detection
  - Recovery

### **Category of Information: Lab Tests**

#### Lab Tests

- Disinfectant residual
- Disinfectant demand
- Total Coliform
- Orthophosphate
- pH
- Temperature
- THM
- HAA5
- Lead and Copper
- Sample Collection

### **Category of Information: General Information**

#### Units of Expression

- Definition
- Conversion

#### Electrical Concepts (Basic)

#### Hydraulic Concepts (Basic)

#### Sources and Characteristics

- Quality/quantity

#### Maps/Plans



# APPLICATION FOR CERTIFICATE OF COMPETENCY

## WATER AND WASTEWATER OPERATOR CERTIFICATION BOARD

Page 2

- This will be the first page you fill out

APPLICATION FOR CERTIFICATE OF COMPETENCY  
Water and Wastewater Operator Certification Board

1. Mark either "Examination" or "Reciprocity" to indicate how you want your application considered. Reciprocity applicants should indicate state, license classification, and license number.

Application for Certification by: Exam    Reciprocity    (If reciprocity) State: \_\_\_\_\_ Class: \_\_\_\_\_ No. \_\_\_\_\_

Do you presently hold a water or wastewater certificate in the state of Tennessee? Yes    No

2. Circle only 1 classification. A separate application must be submitted for each classification for which you are applying.

<p><b>Wastewater Classifications</b></p> <p><input type="checkbox"/> Biological Natural</p> <p><input type="checkbox"/> Wastewater Treatment 1</p> <p><input type="checkbox"/> Wastewater Treatment 2</p> <p><input type="checkbox"/> Wastewater Treatment 3</p> <p><input type="checkbox"/> Wastewater Treatment 4</p> <p><input type="checkbox"/> Collection Systems 1</p> <p><input type="checkbox"/> Collection Systems 2</p>	<p><b>Water Classifications</b></p> <p><input type="checkbox"/> Small Water System</p> <p><input type="checkbox"/> Water Treatment 1</p> <p><input type="checkbox"/> Water Treatment 2</p> <p><input type="checkbox"/> Water Treatment 3</p> <p><input type="checkbox"/> Water Treatment 4</p> <p><input type="checkbox"/> Distribution Systems 1</p> <p><input type="checkbox"/> Distribution Systems 2</p>	<p style="text-align: center; font-size: x-small;"><b>For Board Use Only</b></p> <p>Education _____</p> <p>Months of Experience _____</p> <p>Work O.E. _____</p> <p>College O.E. _____</p> <p>Related O.E. _____</p> <p>TOTAL _____</p> <p>Recommendation _____</p> <p>Reviewer _____</p> <p>Date _____</p> <p>Date of Exam _____</p> <p>Comments _____</p>
-----------------------------------------------------------------------------------------------------------------------------------------------------------------------------------------------------------------------------------------------------------------------------------------------------------------------------------------------------------------------------------------------------------------------------------	--------------------------------------------------------------------------------------------------------------------------------------------------------------------------------------------------------------------------------------------------------------------------------------------------------------------------------------------------------------------------------------------------------------	-------------------------------------------------------------------------------------------------------------------------------------------------------------------------------------------------------------------------------------------------------------------------------------------------------------------------------------------------------------

3. Complete all of the following personal information. All correspondence concerning your application will be sent to the address entered below.

Last Name: \_\_\_\_\_ First Name: \_\_\_\_\_ MI: \_\_\_\_\_

Mailing Address: \_\_\_\_\_

City: \_\_\_\_\_ State: \_\_\_\_\_ Zip: \_\_\_\_\_

Work Phone: (\_\_\_\_) \_\_\_\_\_ Home Phone: (\_\_\_\_) \_\_\_\_\_

Social Security Number: \_\_\_\_\_ Birthdate: \_\_\_\_/\_\_\_\_/\_\_\_\_

Employment County: \_\_\_\_\_ Resident County: \_\_\_\_\_

Email Address: \_\_\_\_\_

Currently Employed At: \_\_\_\_\_

Tennessee Facility I.D. Number: PWSID# \_\_\_\_\_ NPDES# \_\_\_\_\_

I Am A United States Citizen: Yes    No

Check the examination type: Electronic

CN-0704 (Rev 05-22) Page 2 of 8 RDA 2404

**APPLICATION FOR CERTIFICATE OF COMPETENCY  
Water and Wastewater Operator Certification Board**

1. Mark either "Examination" or "Reciprocity" to indicate how you want your application considered. Reciprocity applicants should indicate state, license classification, and license number.

Application for Certification by: Exam  Reciprocity  (If reciprocity) State  Class  No.

Do you presently hold a water or wastewater certificate in the state of Tennessee? Yes  No

2. Circle only 1 classification. A separate application must be submitted for each classification for which you are applying.

Wastewater Classifications	Water Classifications	For Board Use Only
<input type="checkbox"/> Biological Natural	<input type="checkbox"/> Small Water System	Education _____
<input type="checkbox"/> Wastewater Treatment 1	<input type="checkbox"/> Water Treatment 1	Months of Experience _____
<input type="checkbox"/> Wastewater Treatment 2	<input type="checkbox"/> Water Treatment 2	Work O.E. _____
<input type="checkbox"/> Wastewater Treatment 3	<input type="checkbox"/> Water Treatment 3	College O.E. _____
<input type="checkbox"/> Wastewater Treatment 4	<input type="checkbox"/> Water Treatment 4	Related O.E. _____
<input type="checkbox"/> Collection Systems 1	<input type="checkbox"/> Distribution Systems 1	TOTAL _____
<input type="checkbox"/> Collection Systems 2	<input type="checkbox"/> Distribution Systems 2	Recommendation _____
		Reviewer _____
		Date _____

Last Name:  First Name:  M/I:

→ Mailing Address:

City:  State:  Zip:

Work Phone: (  )  Home Phone: (  )

→ Social Security Number:  Birthdate:  /  /

Employment County:  Resident County:

→ Email Address:

Currently Employed At:

→ Tennessee Facility I.D. Number: PWSID#  NPDES#

→ I Am A United States Citizen:  Yes  No

Check the examination type: Electronic

Height	_____
Weight	_____
Eye Color	_____
Sex	_____

Page 3

4. A copy of your high school diploma or GED certificate must be submitted with your application unless you have one on file or are having college transcripts submitted.

Are you a high school graduate? Yes  No  Date of graduation \_\_\_\_\_

If not, do you have a GED certificate? Yes  No  Date received GED \_\_\_\_\_

5. If a college degree is required for the classification for which you are applying or if college work is being claimed as credit for experience, transcripts must be submitted directly to the Board by the college or university. If you are only using your college transcript for proof of high school education, the transcript does not have to be mailed from the school.

Have you graduated from a college or university? Yes  No

School \_\_\_\_\_ Year \_\_\_\_\_ Degree \_\_\_\_\_ Major \_\_\_\_\_

6. List courses and seminars which relate to water/wastewater operations. Proof of successful completion must be included, and course descriptions or catalogs should be attached.

School, Seminars, and Other Training in Water or Wastewater Operations		
Course	Provider	Length of course

Instructions for Completing Job Pages:

7. The following three pages are available for describing related job activities. Complete a job page for each related job. If you need additional pages, make copies of these pages and attach to this application. The information provided will be used to determine your qualifications to take the exam.

Begin with your present or most recent job. List NPDES or PWSID numbers for Tennessee facilities. For each facility that does not have a Tennessee I.D. number, request and complete a Supplement A/B Form.

On each job page are four checklist sections describing operating activities. Place a check mark beside each activity you performed while in that job. At the bottom of each section, list the total percent of time required to perform the activities checked. If the checklist does not adequately describe all of your duties and experience, use the blanks at the bottom of the page for additional information. The total percentage for any job page must not exceed 100%.

To reach your local  
REGIONAL ENVIRONMENTAL FIELD OFFICE  
Call 1-888-891-8332 OR 1-888-891-TDEC

- Please provide copies of the completion for each course listed
- 3 months of operating experience will be given for all WW, WT, DS, SWS, CS, BNS
- Up to 36 months of operating experience can be given for Grade 4 WT, WW only

5. If a college degree is required for the classification for which you are applying or if college work is being claimed as credit for experience, transcripts must be submitted directly to the Board by the college or university. If you are only using your college transcript for proof of high school education, the transcript does not have to be mailed from the school.

Have you graduated from a college or university? Yes  No

School \_\_\_\_\_ Year \_\_\_\_\_ Degree \_\_\_\_\_ Major \_\_\_\_\_

6. List courses and seminars which relate to water/wastewater operations. Proof of successful completion must be included, and course descriptions or catalogs should be attached.

School, Seminars, and Other Training in Water or Wastewater Operations		
Course	Provider	Length of course

Page 4

**Job A: (List most recent position.) (For instructions, see Number 7, page 3.)**  
(Do not show more than 100% for your TOTAL activities in this job.)

Employed: From \_\_\_\_\_ To \_\_\_\_\_ Title of Your Position: \_\_\_\_\_  
 Facility At Which Employed: \_\_\_\_\_ Immediate Supervisor: \_\_\_\_\_  
 TN NPDES # \_\_\_\_\_ or TN PWSID # \_\_\_\_\_ Average Number Hours Worked Per Week: \_\_\_\_\_

**Water Treatment Operations Section**  
 The following activities are acceptable for water treatment plant operating experience. Please place a check mark beside each activity which you perform. List the total percentage of time which you spend performing all of the activities which you checked.

<input type="checkbox"/> Operation & maintenance (O & M) of pretreatment systems	<input type="checkbox"/> Performance of laboratory control tests
<input type="checkbox"/> O & M of coagulant feed systems	<input type="checkbox"/> Interpret laboratory results and make adjustments to improve effluent quality
<input type="checkbox"/> O & M of filtration systems	<input type="checkbox"/> O & M of pumps and motors
<input type="checkbox"/> O & M of flocculent feed systems	<input type="checkbox"/> Plant & ground maintenance
<input type="checkbox"/> O & M of hypochlorination and gas chlorination systems	

TOTAL % TIME SPENT IN THE ABOVE CHECKED ACTIVITIES: \_\_\_\_\_

**Distribution System Operations Section**  
 The following activities are acceptable for water distribution system operating experience. Please place a check mark beside each activity which you perform. List the total percentage of time which you spend performing all of the activities which you checked.

<input type="checkbox"/> Operation & maintenance (O & M) of pumps	<input type="checkbox"/> Pipeline installation
<input type="checkbox"/> O & M of booster station	<input type="checkbox"/> Installation of taps
<input type="checkbox"/> O & M of fire hydrants	<input type="checkbox"/> Leak detection
<input type="checkbox"/> O & M of valves	<input type="checkbox"/> Leak repairs
<input type="checkbox"/> O & M of storage tanks	<input type="checkbox"/> Meter reading
<input type="checkbox"/> Distribution system flushing	<input type="checkbox"/> Close Connection Control

TOTAL % TIME SPENT IN THE ABOVE CHECKED ACTIVITIES: \_\_\_\_\_

**Wastewater Treatment Operations Section**  
 The following activities are acceptable for wastewater treatment plant operating experience. Please place a check mark beside each activity which you perform. List the total percentage of time which you spend performing all of the activities which you checked.

<input type="checkbox"/> Interpret process control data for plant operations	<input type="checkbox"/> Adjustment of wastewater levels or flow patterns through a lagson system
<input type="checkbox"/> Cleaning and maintenance of preliminary treatment, such as bar screens, grit chambers, comminutors, etc.	<input type="checkbox"/> Control of recirculation rates to trickling filters or rotating biological contactor (RBC)
<input type="checkbox"/> Control of sludge pumping	<input type="checkbox"/> Operation of chlorine feed rates for disinfection
<input type="checkbox"/> Control of scum removal in clarifiers	<input type="checkbox"/> Operation of digester and/or solids conditioning processes
<input type="checkbox"/> Control of return and waste sludge rates	<input type="checkbox"/> Perform laboratory control tests
<input type="checkbox"/> Control of aeration rates	<input type="checkbox"/> Interpret lab results to improve effluent quality
<input type="checkbox"/> Perform calculations and use them to operate and control plant	

TOTAL % TIME SPENT IN THE ABOVE CHECKED ACTIVITIES: \_\_\_\_\_

**Collection System Operations Section**  
 The following activities are acceptable for collection system operating experience. Please place a check mark beside each activity which you perform. List the total percentage of time which you spend performing all of the activities which you checked.

<input type="checkbox"/> Operation & maintenance (O & M) of pumps	<input type="checkbox"/> Manhole maintenance and repairs
<input type="checkbox"/> O & M of lift stations	<input type="checkbox"/> Leak detection
<input type="checkbox"/> O & M of valves	<input type="checkbox"/> Line repair
<input type="checkbox"/> Line installation	<input type="checkbox"/> Line clearing
<input type="checkbox"/> Installation of service connections	<input type="checkbox"/> Work on L.V. crew
<input type="checkbox"/> O & M of lines and equipment	

TOTAL % TIME SPENT IN THE ABOVE CHECKED ACTIVITIES: \_\_\_\_\_

% Time	List any duties not covered in the sections above.

CN-0704 (Rev 05-22) Page 4 of 8 RDA 2404

- Make sure the dates are correct for each job page filled out
- NPDES # or PWSID # required
- Total time can only add up to 100%
- Fill out a separate form for each job

**Job A: (List most recent position.) (For instructions, see Number 7, page 3.)**  
(Do not show more than 100% for your TOTAL activities in this job.)

Employed: From \_\_\_\_\_ To \_\_\_\_\_ Title of Your Position: \_\_\_\_\_  
 Facility At Which Employed: \_\_\_\_\_ Immediate Supervisor: \_\_\_\_\_  
 TN NPDES # \_\_\_\_\_ or TN PWSID # \_\_\_\_\_ Average Number Hours Worked Per Week: \_\_\_\_\_

**Water Treatment Operations Section**  
 The following activities are acceptable for water treatment plant operating experience. Please place a check mark beside each activity which you perform. List the total percentage of time which you spend performing all of the activities which you checked.

<input checked="" type="checkbox"/> Operation & maintenance (O & M) of pretreatment systems	<input type="checkbox"/> Performance of laboratory control tests
<input checked="" type="checkbox"/> O & M of coagulant feed systems	<input type="checkbox"/> Interpret laboratory results and make adjustments to improve effluent quality
<input checked="" type="checkbox"/> O & M of filtration systems	<input checked="" type="checkbox"/> O & M of pumps and motors
<input checked="" type="checkbox"/> O & M of flocculent feed systems	<input type="checkbox"/> Plant & ground maintenance
<input checked="" type="checkbox"/> O & M of hypochlorination and gas chlorination systems	

TOTAL % TIME SPENT IN THE ABOVE CHECKED ACTIVITIES: **50%**

**Distribution System Operations Section**  
 The following activities are acceptable for water distribution system operating experience. Please place a check mark beside each activity which you perform. List the total percentage of time which you spend performing all of the activities which you checked.

<input checked="" type="checkbox"/> Operation & maintenance (O & M) of pumps	<input checked="" type="checkbox"/> Pipeline installation
<input checked="" type="checkbox"/> O & M of booster station	<input checked="" type="checkbox"/> Installation of taps
<input checked="" type="checkbox"/> O & M of fire hydrants	<input checked="" type="checkbox"/> Leak detection
<input checked="" type="checkbox"/> O & M of valves	<input checked="" type="checkbox"/> Leak repairs
<input checked="" type="checkbox"/> O & M of storage tanks	<input checked="" type="checkbox"/> Meter reading
<input checked="" type="checkbox"/> Distribution system flushing	<input checked="" type="checkbox"/> Close Connection Control

TOTAL % TIME SPENT IN THE ABOVE CHECKED ACTIVITIES: **50%**

**Wastewater Treatment Operations Section**  
 The following activities are acceptable for wastewater treatment plant operating experience. Please place a check mark beside each activity which you perform. List the total percentage of time which you spend performing all of the activities which you checked.

<input type="checkbox"/> Interpret process control data for plant operations	<input type="checkbox"/> Adjustment of wastewater levels or flow patterns through a lagson system
<input type="checkbox"/> Cleaning and maintenance of preliminary treatment, such as bar screens, grit chambers, comminutors, etc.	<input type="checkbox"/> Control of recirculation rates to trickling filters or rotating biological contactor (RBC)
<input type="checkbox"/> Control of sludge pumping	<input type="checkbox"/> Operation of chlorine feed rates for disinfection
<input type="checkbox"/> Control of scum removal in clarifiers	<input type="checkbox"/> Operation of digester and/or solids conditioning processes
<input type="checkbox"/> Control of return and waste sludge rates	<input type="checkbox"/> Perform laboratory control tests
<input type="checkbox"/> Control of aeration rates	<input type="checkbox"/> Interpret lab results to improve effluent quality
<input type="checkbox"/> Perform calculations and use them to operate and control plant	

TOTAL % TIME SPENT IN THE ABOVE CHECKED ACTIVITIES: \_\_\_\_\_

**Collection System Operations Section**  
 The following activities are acceptable for collection system operating experience. Please place a check mark beside each activity which you perform. List the total percentage of time which you spend performing all of the activities which you checked.

<input type="checkbox"/> Operation & maintenance (O & M) of pumps	<input type="checkbox"/> Manhole maintenance and repairs
<input type="checkbox"/> O & M of lift stations	<input type="checkbox"/> Leak detection
<input type="checkbox"/> O & M of valves	<input type="checkbox"/> Line repair
<input type="checkbox"/> Line installation	<input type="checkbox"/> Line clearing
<input type="checkbox"/> Installation of service connections	<input type="checkbox"/> Work on L.V. crew
<input type="checkbox"/> O & M of lines and equipment	

TOTAL % TIME SPENT IN THE ABOVE CHECKED ACTIVITIES: \_\_\_\_\_

% Time	List any duties not covered in the sections above.

**Job A: (List most recent position.) (For instructions, see Number 7, page 3.)**  
(Do not show more than 100% for your TOTAL activities in this job.)

Employed: From \_\_\_\_\_ To \_\_\_\_\_ Title of Your Position: \_\_\_\_\_  
 Facility At Which Employed: \_\_\_\_\_ Immediate Supervisor: \_\_\_\_\_  
 TN NPDES # \_\_\_\_\_ or TN PWSID # \_\_\_\_\_ Average Number Hours Worked Per Week: \_\_\_\_\_

**Water Treatment Operations Section**  
 The following activities are acceptable for water treatment plant operating experience. Please place a check mark beside each activity which you perform. List the total percentage of time which you spend performing all of the activities which you checked.

<input checked="" type="checkbox"/> Operation & maintenance (O & M) of pretreatment systems	<input checked="" type="checkbox"/> Performance of laboratory control tests
<input checked="" type="checkbox"/> O & M of coagulant feed systems	<input checked="" type="checkbox"/> Interpret laboratory results and make adjustments to improve effluent quality
<input checked="" type="checkbox"/> O & M of filtration systems	<input checked="" type="checkbox"/> O & M of pumps and motors
<input checked="" type="checkbox"/> O & M of flocculent feed systems	<input checked="" type="checkbox"/> Plant & ground maintenance
<input checked="" type="checkbox"/> O & M of hypochlorination and gas chlorination systems	

TOTAL % TIME SPENT IN THE ABOVE CHECKED ACTIVITIES: **100%**

**Distribution System Operations Section**  
 The following activities are acceptable for water distribution system operating experience. Please place a check mark beside each activity which you perform. List the total percentage of time which you spend performing all of the activities which you checked.

<input checked="" type="checkbox"/> Operation & maintenance (O & M) of pumps	<input checked="" type="checkbox"/> Pipeline installation
<input checked="" type="checkbox"/> O & M of booster station	<input checked="" type="checkbox"/> Installation of taps
<input checked="" type="checkbox"/> O & M of fire hydrants	<input checked="" type="checkbox"/> Leak detection
<input checked="" type="checkbox"/> O & M of valves	<input checked="" type="checkbox"/> Leak repairs
<input checked="" type="checkbox"/> O & M of storage tanks	<input checked="" type="checkbox"/> Meter reading
<input checked="" type="checkbox"/> Distribution system flushing	<input checked="" type="checkbox"/> Close Connection Control

TOTAL % TIME SPENT IN THE ABOVE CHECKED ACTIVITIES: \_\_\_\_\_

**Wastewater Treatment Operations Section**  
 The following activities are acceptable for wastewater treatment plant operating experience. Please place a check mark beside each activity which you perform. List the total percentage of time which you spend performing all of the activities which you checked.

<input type="checkbox"/> Interpret process control data for plant operations	<input type="checkbox"/> Adjustment of wastewater levels or flow patterns through a lagson system
<input type="checkbox"/> Cleaning and maintenance of preliminary treatment, such as bar screens, grit chambers, comminutors, etc.	<input type="checkbox"/> Control of recirculation rates to trickling filters or rotating biological contactor (RBC)
<input type="checkbox"/> Control of sludge pumping	<input type="checkbox"/> Operation of chlorine feed rates for disinfection
<input type="checkbox"/> Control of scum removal in clarifiers	<input type="checkbox"/> Operation of digester and/or solids conditioning processes
<input type="checkbox"/> Control of return and waste sludge rates	<input type="checkbox"/> Perform laboratory control tests
<input type="checkbox"/> Control of aeration rates	<input type="checkbox"/> Interpret lab results to improve effluent quality
<input type="checkbox"/> Perform calculations and use them to operate and control plant	

TOTAL % TIME SPENT IN THE ABOVE CHECKED ACTIVITIES: \_\_\_\_\_

**Collection System Operations Section**  
 The following activities are acceptable for collection system operating experience. Please place a check mark beside each activity which you perform. List the total percentage of time which you spend performing all of the activities which you checked.

<input type="checkbox"/> Operation & maintenance (O & M) of pumps	<input type="checkbox"/> Manhole maintenance and repairs
<input type="checkbox"/> O & M of lift stations	<input type="checkbox"/> Leak detection
<input type="checkbox"/> O & M of valves	<input type="checkbox"/> Line repair
<input type="checkbox"/> Line installation	<input type="checkbox"/> Line clearing
<input type="checkbox"/> Installation of service connections	<input type="checkbox"/> Work on L.V. crew
<input type="checkbox"/> O & M of lines and equipment	

TOTAL % TIME SPENT IN THE ABOVE CHECKED ACTIVITIES: \_\_\_\_\_

% Time	List any duties not covered in the sections above.

Overview

9



Page 8

- Certified Operator signing **MUST** be equal to or higher than exam sitting for by applicant. Must include certification #.
- If none available, then fill out gray box.
- Please sign application

<p>9. Verification of work experience must be documented by a certified operator of a similar or higher classification, familiar with the applicant's work experience. <u>However, if no such person is available, experience may be documented by a person in authority with the system.</u></p> <p>I hereby certify the information contained in the work experience section of this application is true and correct to the best of my knowledge. As specified in Tennessee Code Annotated Section 39-16-702(a)(4), this declaration is made under penalty of perjury.</p> <p>I have observed this applicant for ____ years.</p>											
<p>Name of Certified Operator documenting work experience: (Please Print)</p>	<p>Certification Number (s):</p>										
<p>Signature of Certified Operator:</p>											
<p><b>Complete This Section Only If A Certified Operator Of Similar Or Higher Classification Is Not Available.</b></p> <table border="1"> <tr> <td> <p>Printed name and signature of person in authority of the applicant's system documenting work experience: <i>(if different than above)</i></p> </td> <td> <p>System's Person in Authority Name and Position Title: <i>(if different than above)</i></p> </td> </tr> <tr> <td> <p>Name of facility/utility/system:</p> </td> <td> <p>Telephone number: <i>(include area code)</i></p> </td> </tr> <tr> <td colspan="2"> <p>Address: <i>(number and street)</i></p> </td> </tr> <tr> <td> <p>City:</p> </td> <td> <p>State:</p> </td> </tr> <tr> <td colspan="2"> <p>Zip code:</p> </td> </tr> </table>		<p>Printed name and signature of person in authority of the applicant's system documenting work experience: <i>(if different than above)</i></p>	<p>System's Person in Authority Name and Position Title: <i>(if different than above)</i></p>	<p>Name of facility/utility/system:</p>	<p>Telephone number: <i>(include area code)</i></p>	<p>Address: <i>(number and street)</i></p>		<p>City:</p>	<p>State:</p>	<p>Zip code:</p>	
<p>Printed name and signature of person in authority of the applicant's system documenting work experience: <i>(if different than above)</i></p>	<p>System's Person in Authority Name and Position Title: <i>(if different than above)</i></p>										
<p>Name of facility/utility/system:</p>	<p>Telephone number: <i>(include area code)</i></p>										
<p>Address: <i>(number and street)</i></p>											
<p>City:</p>	<p>State:</p>										
<p>Zip code:</p>											
<p>10. Application must be signed and dated. By signing, applicant verifies that all information supplied on this application is correct to the best of his/her knowledge.</p> <p>I certify under penalty of law that this document and all attachments were prepared by me, or under my direction or supervision. The submitted information is to the best of my knowledge and belief true, accurate, and complete; and that I am lawfully present in the United States as a U.S. citizen or a qualified alien as defined in 8 U.S.C. §1641(b). I am aware that there are significant penalties for submitting false information, including the possibility of fine and imprisonment. As specified in Tennessee Code Annotated Section 39-16-702(a)(4), this declaration is made under penalty of perjury.</p>											
<p>Date of Application</p>	<p>Signature of applicant</p>										





**Section 2**  
**System Design & Pipes**



## Distribution System Design

### Learning Objectives

- Types of water systems
- Common configurations use in distribution system design
- Principal considerations involved in sizing water mains
- Considerations made for selecting piping materials

### Types of Water Systems

- Surface water supply
- Groundwater
- Purchased water
- Rural Systems
  - Small water systems

### Surface Water Systems

- Usually provides water for large communities with a lot of industrial and commercial usage
- Requires more treatment than groundwater
- Water usually enters the distribution system from one side and requires large transmission mains
- Water use on high-use days may be several times the amount on average day

### Groundwater Systems

- Usually has limited withdrawal rates
- Requires less treatment than surface water
- Wells are dispersed in some systems, require less transmission mains
- Water may be corrosive or scale-forming
- Rate of water use sometimes exceeds the water source (aquifer)
- If single entry point, distribution system must be furnished with transmission mains as in the case of surface water system

### Purchased Water Systems

- 3 principal reasons utilities purchase water
  - Well supply becomes inadequate
  - Water sources found to be contaminated
  - Regulatory compliance makes supply and treatment too difficult
- Operator's job is limited to primarily the distribution system
  - In some cases, additional disinfection may be required
- Tight water accountability must be maintained in the distribution system

## Factors Affecting Distribution Design

- Water availability and reliability
- Soil conditions and climate
  - How deep to put lines
  - What kind of pipe to use
- Terrain
- Water quality

## Factors Affecting Distribution Design

- State and Federal requirements
- Future growth
- Costs: materials, labor, overhead, profit, land acquisition, legal expenses and engineering

## Factors Affecting System Layout

- System planning
- Configuration
- Mapping
- Valving

## System Planning

- Design should be done by city engineer or consultant
- Operators should be included in the process
- Important to include operators because they will have to make it work

## Types of Water Mains

- Distribution mains
  - Any pipe in the distribution system other than a service line
- Transmission mains
  - *Large pipeline used to transport water over long distances*
- Arterial mains
  - Sometimes called trunk mains or feeders
  - *Large diameter mains that carry water to a service area*
- Service lines
  - Pipeline extending from the water main to the building served or the consumer's system

## Transmission Mains

- Carry water from source of treatment to distribution system
- Generally straight
- No service connections
- Usually made of large pipe
- Size depends upon flow demand and available operational storage facilities
- Concrete with a steel cylinder is suitable because less expensive in larger sizes

## Arterial Mains

- Carry water from transmission main
- Main arteries that carry water to neighborhoods
- Can be tapped for customer connections

## Service Lines

- Small diameter pipe
- Connect from distribution main to customer
- Start with a corporation stop (shutoff valve)
- Various material are used commonly plastic pipe, PVC, Polyethylene, and Polybutylene
- Lead service lines no longer acceptable and should be replaced

## System Configuration

- Usually one of three types:
  - Arterial-loop
  - Grid
  - Tree
- Most systems are combination of grid and tree (branching system)

## Arterial-Loop System Characteristics

- Attempts to surround the distribution area with large diameter mains
- Mains contribute water supply within the grid from several directions
- All major demand areas should be served by an arterial system
- Minimizes dead ends
- Branch mains project inward
- Fewer service interruptions with line breaks

## Arterial-Loop System

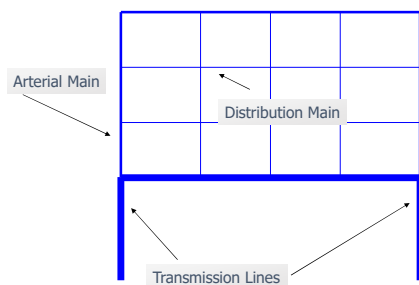

## Grid System Characteristics

- Depends on the fact that all mains are interconnected
- Water can flow from several different directions
- Mains are usually 6 - 8 inches
- Reinforced with larger arterial mains
- General area is fed by larger transmission mains
- All ends of mains are connected to eliminate dead ends

## Grid System Characteristics

- Minor distribution lines or mains make up secondary system which is the major portion of the grid which supply fire hydrants & domestic and commercial consumers

## Grid System

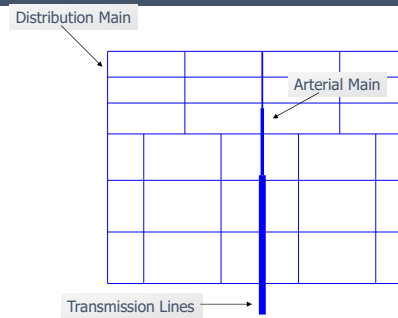

## Tree System Characteristics

- Not highly recommended
- Few loops - flows often in one direction
- Difficult to supply a continuous flow of water to all parts of the system
- Customers are without water while repairs made to line breaks

## Tree System Characteristics

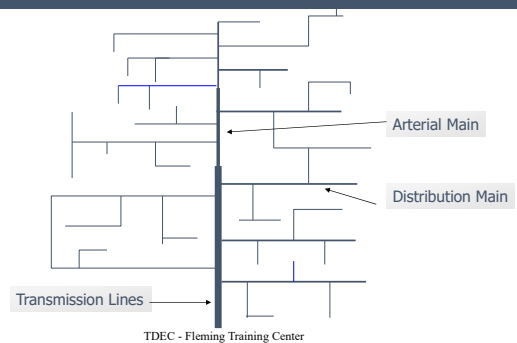

## Dead Ends

- Water flows in one direction
- Provides limited fire protection flow
- Mains are usually oversized for fire flow
- Domestic use is not enough to prevent stagnation and water degradation
- Customers beyond repair site are without water during work

## Dead Ends

- Should have hydrant installed for flushing and fire protection
- Flush with a minimum velocity of 2.0 ft/sec
- Should be avoided whenever possible

### Factors for Sizing Water Mains

- Quantity requirements depends on consumption and fire flow requirements
- No main may be less than 6 inches in diameter for fire protection
- High value districts should have minimum pipe size of 8-12 inches

### Factors for Sizing Water Mains

- Residential areas: 6-8 inch lines
- Mains smaller than 6 inches used only when completing a grid
- Varying elevation areas usually require two or more pressure zones
- Higher pressures contribute to more main and service line leaks

### Water Pressure Requirements and Considerations

- Normal working pressure 50 - 75 psi for residential areas
- Minimum: 20 psi (under all flow conditions)
- Maximum: 100 psi
- Pressure reducing valves used if greater pressure exists (some building codes require in newer subdivisions)

### Water Pressure Requirements and Considerations

- High pressure contributes to main and service leak problems
- Booster pumps often required for larger systems
- Ideal system would rely completely on gravity

### Flow Velocity Requirements and Considerations

- Determines pipe capacity and required size
- Normally limited to about 5 ft/sec
- Higher velocities cause excessive friction loss as water flows through pipe
- Large variations of flow can adversely affect water quality

### Flow Velocity Requirements and Considerations

- Sediments can be carried to customer with flow velocity changes
- Low circulation can result in growth of organisms, corrosion products, depletion of oxygen and increased rates of taste and odor
- Turbulence can cause air in system which produces milky water

## Pipe Material Selection Consideration

- What qualities should the pipe have?
- What are the performance ratings of the pipe?
- What pipe material is available?
- What materials are currently used in distribution system?
- Are existing materials compatible?
- COST \$\$\$\$\$\$

## Pipe Qualities Selection Considerations

- Can it handle external load from backfill?
- Can it handle internal pressures within pipe?
- Normally within 40-100 psi range
- Water hammer and surges
- Tensile strength
- Flexible or flexural strength
- Pipe shear breakage when earth shifts
- Beam breakage

## Piping Terms

- **External load** - the pressure exerted on a pipe after it has been buried in a trench
- **Internal pressure** - the hydrostatic pressure from within the pipe
- **Tensile strength** - the resistance of a material to longitudinal (lengthwise) pull
- **Flexural strength** - the ability of a material to bend or flex without breaking

## Piping Terms

- Pipe shear breakage or beam breakage may occur when a force exerted on a pipe causes stresses that exceed the tensile or flexural strength
- **Shear breakage** – occurs when the earth shifts
- **Beam breakage** – occurs when a pipe is unevenly supported along its length

## Pressure Rating of Pipe Material

- Pressure ratings can be calculated using AWWA standards
- Distribution pipe should have pressure rating 2.5 - 4 times normal operating pressure
- Replacement pipe must have a pressure rating greater than or equal to that replaced

## Other Considerations

- |                                     |                                                      |
|-------------------------------------|------------------------------------------------------|
| ➤ Durability & life span            | ➤ Compatibility                                      |
| ➤ Corrosion resistance              | ➤ Local conditions                                   |
| ➤ Roughness of inner surface        | ➤ Installation COSTS                                 |
| - <b>C Factor</b>                   | ➤ All pipe must meet AWWA Standards                  |
| ➤ Ease of installation              | ➤ Tennessee Design Criteria for Distribution Systems |
| ➤ Ease of tapping & repair          |                                                      |
| ➤ Ability to maintain water quality |                                                      |

## Pipes



- Materials, Installation & Maintenance

## Objectives

- Piping Materials
- Main Installation
- Backfilling and Testing

## Piping Materials



## Types of Pipe

- CIP (Cast Iron Pipe)
- DIP (Ductile-Iron)
- Steel Pipe
- Asbestos-cement pipe (AC)
- Plastic
- Concrete

## Gray Cast-Iron Pipe

- Used as early as 1664 in France
- Called sand-cast pipe
- Some systems are over 100 years old in US
- Strong but brittle
- Older pipe can be identified by rough texture on outside wall
- Since 1920, produced by centrifugal process - outside walls smoother and uniform in size
- Beam break most common
- No longer used for manufacturing pipe
- Still used to make some valves and fittings

## Ductile-Iron Pipe (DIP)

- Became popular in 1960's
- More modern, tougher type of cast iron pipe
- Produced in same type mold as CIP
- Has "ductile iron" stenciled to distinguish from CIP
- Graphite distributed in the metal
- Much stronger than CIP
- Polyethylene wrap on pipe commonly used to prevent corrosion





### Advantages of DIP

- Good durability
- Flexural strength
  - Will resist bending and twisting without breaking
- Smooth interior (C140)
- Carrying capacity
- Fracture resistance
- External corrosion good in most type soils
- Withstand high pressure
- Long term economical
- Diversity when combined with different fittings, joints, valves

### Disadvantages of DIP

- External corrosion in aggressive environments if not protected
- Reliant upon special linings to protect against corrosion
- Costly to maintain
- Greater weight increases difficulty of installation

### Ductile-Iron Pipe Joints

- Flanged
- Mechanical
- Ball-and-Socket (Submarine)
- Push-on
- Restrained
- Grooved and Shouldered

### Flanged Joints



- Two machined surfaces tightly bolted together with a gasket between them
- Used in exposed locations
- Should not be used underground
  - Due to lack of flexibility to compensate for ground movement
- Used at treatment plant & pump stations

### Mechanical Joints

- Movable follower ring on the spigot to the flange on the bell
- Follower ring compresses a rubber gasket to form a seal
- More expensive
- Make a very positive seal and require little technical expertise to install
- Allow for some deflection of the pipe
- Provide flexibility in event of ground settlement after pipe installation

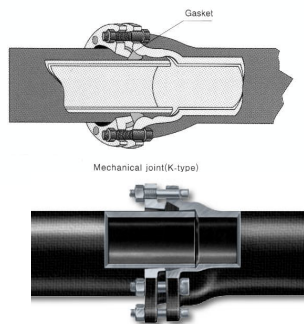

### Ball-Socket Joint

- Special purpose joints used for intakes and river crossings
- Provide large deflection
- Used in rough terrain
- Joint consists of bell with special recess to accept a rubber ring gasket
- Available in several designs
- Deflections up to 15°
- Available in bolted and unbolted



### Push-On Joints

- Most popular
- Easier installation
- Lower cost
- Consists of a special bell fitted with a greased gasket
- Spigot end must have beveled edge to prevent tearing the rubber ring gasket
- Available in several designs
- Internal water pressure compresses the gasket making tight seals

The diagram shows a cross-section of a push-on joint. It features a spigot end of a pipe with a beveled edge that fits into a bell-shaped housing. A gasket is positioned between the spigot and the housing. Labels include 'Gasket' and 'Push-on joint(T-type)'. Below the diagram is a photograph of a blue pipe with a metal ring being applied to a joint.

### Restrained Joint

- Used to ensure joints do not separate such as elbows
- Used in areas where concrete thrust blocks cannot be used
- Some have special restraining feature

A photograph of a restrained joint assembly. It shows a metal coupling with a central U-shaped rubber gasket. The coupling is designed to lock the pipe ends together and compress the gasket against the outside of the pipe ends.

### Grooved & Shoulder Joints

- Grooved
  - Utilizes bolted, segmental, clamp-type, mechanical coupling
  - Housing encloses a U-shaped rubber gasket
  - Housing locks the pipe ends together
  - Compresses the gasket against outside of pipe ends
  - Ends of pipe are machine grooved to accept housing
- Shoulder
  - Similar to grooved
  - Pipe ends are shouldered instead of grooved

The diagram shows a cross-section of a grooved and shoulder joint. It features a metal housing that encloses a U-shaped rubber gasket. The housing locks the pipe ends together and compresses the gasket against the outside of the pipe ends. Labels include 'Gasket', 'Housing', 'Groove', and 'Bolt/Nut'.

### Steel Pipe Characteristics

- More often for high-pressure situations
- Relatively light weight
- Competitively priced (i.e. over 16" diameter)
- Will bend without buckling
- High tensile strength
- Is subject to internal and external corrosion

### Steel Pipe Characteristics

- Has cement mortar or epoxy lining
- Partial vacuum can cause pipe distortion or collapse
- Exterior requires corrosion and abrasion protection
- Frequently used for in-plant piping
- May have cathodic protection

## Steel Pipe Joints and Fittings

- Pipe lengths often joined by welding
- Mechanical joints used
- Cast iron or ductile-iron fittings
- Joints
  - Bell and spigot joints
  - Carnegie shape rubber gasket joint
  - Mechanically coupled joint
  - Flanged joint for bolting
  - Butt welded joint

## Asbestos-Cement Pipe Characteristics

- Often preferred in areas with corrosive soil
- Lightweight, low initial cost
- Made of asbestos fibers, silica sand, and Portland cement
- Asbestos fibers provide much of the strength
- Not subject to metallic corrosion, tuberculation, and C factor usually stays high

## Asbestos-Cement Pipe Characteristics



- Should not be used with very aggressive or soft water, or aggressive soils
- Proper bedding is required to prevent breaks
- Easily punctured during excavations
- Low flexural strength
- Requires safety PPE (personal protective equipment)
- Cannot be located with pipe locators

## Asbestos-Cement Pipe Joints

- Joined by sleeved couplings, also asbestos cement
- Sleeve has 2 interior rubber rings
- Cast-iron or ductile-iron fittings used, except couplings
- Asbestos in water does not cause health effects
- PVC is replacing AC pipe

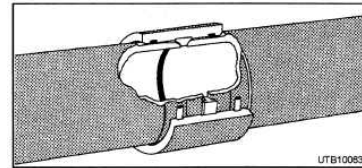

## Plastic Pipe Characteristics

- Inert - will not react or corrode
- Widely used in water utility industry
- Will not leach out taste and odor causing substances
- Smooth interior
- Must be NSF International Standard 61 certified and marked on exterior surface
- Organic compounds can permeate (gas, fuel, oil)
- Should not be installed where contamination from organic compounds is probable

## Plastic Pipe Types

- PVC – polyvinyl chloride
  - Most common
- PE – polyethylene
- PB – polybutylene
  - not used for water services

## Plastic Pipe Joints

- PVC
  - Bell and spigot
  - Solvent weld
  - Threading (>schedule 80 pipe)
- PE
  - Heat fusion

## PVC (Polyvinyl Chloride) Pipe Characteristics and Advantages

- Most commonly used plastic pipe
- Generally lower cost
- Cheaper to ship
- Easier to handle
- Cuts easier
- C Factor of at least 150
- Chemically inert
- Moderately flexible and will adapt to ground settling



## PVC Disadvantages

- Susceptible to damage from UV
- Permeable by organics
- Requires careful bedding to prevent damage
- Difficult to locate because nonconductive
- Inability to be thawed electrically
- Susceptible to permeation
- Buckles under a vacuum
- Must adhere to use of proper tools and procedures when service taps are made

## Concrete Pipe Types



- Pre-stressed Cylinder
- Pre-tensioned
- Reinforced
- Reinforced non-cylinder

## Prestressed Concrete Cylinder Pipes

- Two types manufactured
  - Lined-cylinder available in diameters from 16 - 60 inches
  - Embedded-cylinder available in diameters from 24 - 144 inches
- Manufactured with a full length of welded steel cylinder
- Concrete core in the interior

## Pretensioned (Rod-Wrapped) Concrete Cylinder Pipe

- Similar to pre-stressed, but cylinder is wrapped with smooth hot-rolled steel bar
- Core protected with mortar coating
- Normally available in diameters of 10 - 54 inches

## Advantages of Concrete Pipe

- Manufactured inexpensively in large sizes
- Withstands high internal pressure and external load
- Resistant to both internal and external corrosion
- Very long and trouble-free life span, if properly installed
- Minimal bedding requirements

## Disadvantages of Concrete Pipe

- Very heavy weight
- Shipping costs high
- Special handling equipment required
- Exact pipe fittings and lengths required for installation
- Must be carefully planned and laid out in advance

## Main Installation



## Pipe Shipping and Unloading

- Can be shipped via truck, railroad or barge
- Pipe should be inspected upon arrival
- Handle carefully
- Inspect lining and coating
- Plastic pipe inspected closely if arriving in cold weather
- Use proper equipment to unload

## Stacking Pipe

- If pipe is to be stacked and stored - ensure it is stored off the ground
- Secure pipe to prevent rolling
- Secure the storage area
- Protect plastic pipe from sunlight - but allow air circulation
  - Pipe stored outside greater than 30 days should be protected





### Stringing Pipe

- Pipe should be laid as near to the trench as possible to minimize handling
- String pipe on opposite side of spoil pile
- Place bells in direction of installation
- Secure each section to prevent rolling into trench
- String only enough for one days work to prevent vandalism
- May need to cover ends to keep dirt out and prevent contamination

### Excavation

- Plans are prepared by project engineer and submitted for State approval 30 days before scheduled construction
- Plans should show location and depth of main, valves, hydrants and fittings
- Plans should show location and depth of sewer and gas pipes, buried telephone lines, electric and cable lines
- Ensure selection of proper sized excavation equipment
- Notification to public
- Tennessee One Call

### Excavation

- Water and Sewer lines separation at least **18 in** between the bottom of the water main and top of the sewer line
- Water mains should be at least **10 ft** horizontally from any sewer line

### Trenching

- Most expensive part of main installation
- Minimize width and depth as much as possible without compromising safety
- Width should be no more than 1-2 ft more than pipe diameter, wider around curves
- Trench depth depends on maximum depth of frost penetration, minimum of 2.5 feet
- Minimum distance from trench to spoil pile is 2 feet

## Trenching

- Must have egress if 4 feet or deeper - stairway, ladders
- **Trench must be shored or sloped at 5 feet or deeper**
- If 20 feet or deeper, must be designed by an engineer
- Left open as short a time as possible
- Mark with barricades, warning tape, lights, etc to prevent accidents

## Pipe Laying Procedures



- Inspect before laying and placing in trench
- Check for damage to the spigot end and lining
- Tap gently with a hammer (should ring)
- Wash, hose, or swab with hypochlorite if excessively dirty

## Pipe Laying Procedures

- Keep gaskets clean and dry
- Use a sling or pipe tong to place into trench - never roll
- Cover pipe with plug at the end of each work day
- Ensure pipe bedding is level and compacted
- Compact the backfill beneath the pipe curvature (**Haunching**)

## Pipe Joints

- Ensure gasket and spigot are clean before being attached
- Bell holes or recesses in bedding dug to allow for joint installation
- Spigot end must be inserted to the painted line
- Full-length pipes are beveled at end to facilitate connection
- Level pipe for cutting
- Insert pipe straight

## Connecting to an Existing Main

- Shut off water to existing main and ensure valve will hold
- Must know the size and type of main to get proper fittings and gaskets
- Connecting to main using pressure taps
  - Does not require shutting off water and
  - Less chance of contaminating water
  - Also, fire protection remains in service for the area

## Thrust Restraints in Pipe Installation

- Water under pressure and water in motion exerts tremendous pressure inside a pipe
- All tees, bends, reducers, caps, plugs, valves and hydrants should be restrained or blocked
- 4 general methods
  - thrust blocks
  - thrust anchors
  - restraining joints or fittings
  - batter piles

## Thrust Restraints in Pipe Installation

- **Thrust blocks** are made of concrete or other permanent material and are cast in place between fittings and undisturbed soil in the trench
- **Thrust anchors** can be used when there is no undisturbed solid structure to block against, so a thrust block is not usable
  - steel rods hold the pipe and are attached to a block of concrete

## Thrust Restraints in Pipe Installation

- **Tie rods** are used to restrain mechanical joint fittings that are located close together
  - nuts on either side of each joint take the place of the MJ bolt that they replace
- **Restraining fittings** use clamps and anchor screws
  - useful where other existing utilities or structures are so numerous that thrust blocks aren't usable

## Piping Air Relief

- Air gets trapped in water mains laid on uneven ground
- Constricts water flow
- In small mains, can be removed by flushing
- Removal possible in corporation stops
- Automatic air-relief can be installed at each high point in pipeline

## Backfilling and Testing



## Purpose of Backfilling

- Provide for pipe and fitting support
- Provides lateral stability between pipe and trench walls
- Prevents pipe movement during water hammer
- Carries and transfers surface loads

## Placing Backfill

- Only clean sand or selected soil should be used for first layer
- Moist enough for compaction
- Should not contain peat, large rocks, debris or frozen material
- First layer placed equally on both sides of pipe, up to center, and compacted
- Do by hand or pneumatic tamper
- Second layer should be good quality backfill material
- Remaining backfill can be excavated spoils



### Compacting



Tamping Soil

- Three methods for compacting soil
  - Tamping
  - Vibration
  - Saturation with water
- Depends upon the type of soil or material used

### Pressure and Leak Testing

- **Leakage** – the volume of water that must be added to the full pipeline to maintain a specific test pressure within a 5 psi range
- Mains tested after trench has been partially filled
- Should be done before trench is completely closed so that any leakage can be observed and repaired easily

### Leak Testing Procedure

1. Allow at least 5 days for the concrete used for thrust blocks to cure
2. Install pressure pump equipped with a make up reservoir, a pressure gauge, and a method for measuring the amount of water pumped
3. Close all appropriate valves
4. Slowly fill test section with water while expelling air at all high points
5. Start applying partial pressure with positive displacement pump

### Leak Testing Procedure

6. Once lines full, leave partial pressure on & allow line to stand for 24 hours to stabilize
7. **Subject test line to pressure of either 1.5 times the operating pressure or 150 psi, whichever is greater, for at least 30 minutes**
8. Examine installed pipe & fittings for visible leaks/pipe movement
9. After test pressure has been maintained for at least 2 hours, conduct leakage test by using the makeup reservoir and measuring the amount of water that has to be used to maintain specified test pressure

### Leak Testing Procedure

10. Compare amount of leakage to allowable leakage given appropriate AWWA standard
  - Swift loss of pressure is likely due to break in the line or an open valve
  - Slow loss of pressure may be due to leaking valve or pipe joint

### Pressure and Leak Testing

- Test pressure and allowable leakage are in AWWA Standards
- Any leaking joints, valves, etc should be adjusted or repaired
- Possible causes for leaks are:
  - Debris lodging a valve
  - Improperly tightened joints
  - Partially open corporation
  - Damage to pipe stops

## Pipe Flushing

- New lines must be flushed, disinfected, and tested for bacteriological quality before placing into service
- Velocity of at least 2.5 ft/sec
- For large diameter mains, more than one hydrant may be used OR 3 times the volume of the main (AWWA C651)
- A blow off connection may be used if installed
- A pig may be used if water plant capacity not sufficient to provide the quantity of water required for flushing line

## Disinfection

- Calcium or sodium hypochlorite
- Ensure chlorinated water in pipe for 24 hours
- All valves and hydrants operated to ensure disinfection of all parts
- Should bleed periodically to ensure water movement
- Inject liquid bleach through corporation stop
- When completed, high chlorinated water is flushed out
- Coordinate with wastewater plant before discharging highly chlorinated water into sewer
- Contact State if environmental effects occur

## Methods of Disinfecting

- Tablet Method
- Continuous Feed Method
- Slug Method

## Water Main Cleaning

- Mechanical cleaning may be necessary to clear tuberculation and deposits of older pipes
- Should first try to clean by flushing
- Devices such as swabs or pigs may be needed
- Cleaning operations can increase the flow rates through pipe
- Valves and hydrants should be checked prior to cleaning

## Water Main Cleaning

- Customers notified
- Temporary water service for customers
- Must be able to control pressure surges in system
- Flush until water clear
- Conduct flow test

## Bacteriological Testing

- **State requires two consecutive sets of samples taken 24 hours apart OR one set 48 hours after disinfecting new lines**
- **Samples shall be taken from each 2500 feet of main with samples near the beginning and at the end point**
- Requires 24 hour incubation
- Must be absent of coliforms
- "If the newly constructed facility yields positive bacterial samples, the line shall be flushed, and resampled. If subsequent samples are positive, the line shall be re-disinfected, flushed and sampled again."

State Rules 0400-45-01-.17(8)(b)

## Site Restoration

- Restored to original condition as soon as possible
- Grass restored, curbs replaced, pavement repaired
- Final inspection should include marked location of valves, hydrants and all in full open position
- Note number of turns to open valves, direction to open
- Check drainage ditches for debris which would facilitate flooding
- Private property must be returned to original condition

## Safety

- Wear hard hats when necessary
- Follow safety guidelines, including sloping and shoring
- Use proper traffic control measures: warning signs, traffic cones, tape off restricted and danger areas, caution lights
- Use proper precautions when unloading pipe
- Get a permit (Tennessee One Call) before excavating
- Use proper Personal Protective Equipment when handling chlorine, etc.

## Distribution System Operations & Maintenance



- California State University: Sacramento
- AWWA Water Transmission and Distribution

## Objectives

- Leak Detection Methods
- Water Audits
- Emergency Leak Repair

## Leak Detection



## Locating Leaks

- Unaccounted-for water - difference between water produced/purchased by system and total water metered to customers
  - Now known as non-revenue water
- Large Leaks
  - Usually easy to find as water will find its way to the surface
- Small Leaks
  - More difficult to find as water can be absorbed into soil or flow into sewers



## Leak Detection Methods

- Listening Surveys
  - An acoustic listening device can be systematically used to locate leaks
  - Detects sound waves created by escaping water
- Mechanical listening devices
  - Aquaphone – resembles old fashioned telephone with a spike
  - Geophone – looks like a stethoscope connected to two diaphragms
  - Diaphragms placed on ground and sound is amplified



## Leak Detection Methods

- Electronic listening devices - electronic amplifiers for listening for sounds at the ground surface, probes, and direct-contact devices
  - Can use adjustable filters to remove sound such as wind or traffic
  - Dead ends, partially closed valves, joints can amplify leak sounds



## Leak Detection Methods

- Correlator Method – Third party performs listening survey with correlator
  - Computer that uses data from transducers that will analyze the speed with which the sound travelled
  - Can usually accurately pinpoint a leak

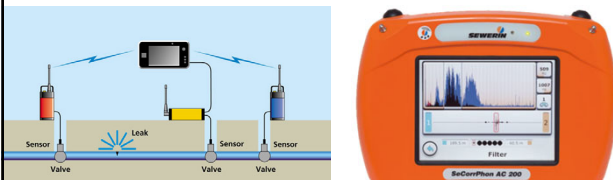

## Locating Leaks



\* Leak detection with a time-integral acoustic bar

\* Leak detection with a correlation leak detector

\* Leak detection with an electronic leak detector

## Factors Affecting Leak Detection

- Mains with rubber gasket joints often do not transmit sound much past the pipe section that has the leak
- Copper transmits sound best followed by steel, cast & ductile-iron, plastic, asbestos cement, and concrete
- Smaller pipes transmit sound well and decreases as diameter increases
- Tees, elbows, and other fittings often amplify sounds, making hearing the leak more difficult
- Dry, sandy soils produce the best noise transmittance
- Gravel roads and lawn areas are poor transmitters
- Noise can be contributed by other buried services

## Water Audits



## Water Audits

- Thorough examination of the accuracy of utility records (volumes of water) and system control equipment
- Performed when significant water loss can not be explained
- Collect distribution system information

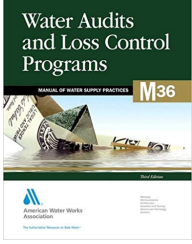

## Water Audits

- Thorough examination of the accuracy of utility records (volumes of water) and system control equipment
- Performed when significant water loss can not be explained
- Collect distribution system information
- Measure water supplied to DS
- Quantify billed consumption
- Calculate nonrevenue water
- Quantify unbilled authorized consumption
- Quantify water loss
- Quantify apparent losses
- Quantify real losses
- Assign costs of losses
- Calculate performance indicators
- Compile water balance

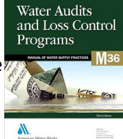

## Emergency Leak Repair



## Emergency Leak Repairs

- Completely or partially shut down leaking line to minimize water loss
  - If damage to property or danger to public is possible, water should be shut off completely
- Notify customers who will be without water
- If leak is at the bottom of a hill, up hill curb stops should be shut off to prevent back siphoning



## Emergency Leak Repairs

- Leak may not be directly below where water comes to surface
- Utility should pinpoint the leak using listening device and probe before digging
  - May have to turn water back on
- Large leak can compromise roads, walks, railways or other utilities
- Remember to Call Before You Dig!



## Emergency Leak Repair

- Excavation
  - Pump for dewatering trench
  - Ladder for entering and leaving excavation
  - Shovels, wrenches, hand tools
  - Planks and timbers for shoring
  - Traffic control equipment
  - Pipe cutters or saws
  - Air compressor and hammer to cut through pavement
  - Generator, lights and flashlights
  - Safety ropes or ladders

## Emergency Leak Repair

- If break is severe, damaged section may have to be cut away and replaced
- All new pipe and appurtenances must be disinfected with chlorine before installation
  - Keep record of disinfection process
- Simplest method is repair clamps
- After uncovering pipe, clean as much dirt and corrosion away as possible
- When applying clamp, make sure no foreign material sticks to gasket and pipe
- Tar coating may be used for rust prevention
- After repair, flush line to remove air or dirt

## Distribution Systems Pipe Vocabulary

- |                           |                       |
|---------------------------|-----------------------|
| A. Angle of Repose        | R. Sloping            |
| B. Appurtenance           | S. Slug Method        |
| C. Arterial-Loop System   | T. Spring Line        |
| D. Bedding                | U. Stringer           |
| E. Continuous-feed Method | V. Surge Pressure     |
| F. Corrosion              | W. Swab               |
| G. C Value                | X. Tablet Method      |
| H. Distribution Main      | Y. Tensile Strength   |
| I. External Load          | Z. Thrust             |
| J. Flexural Strength      | AA. Thrust Anchor     |
| K. Grid System            | BB. Thrust Block      |
| L. Hydrostatic Pressure   | CC. Transmission Line |
| M. Internal Load          | DD. Tree System       |
| N. Pig                    | EE. Trench Brace      |
| O. Service Connection     | FF. Upright           |
| P. Shielding              | GG. Water Hammer      |
| Q. Shoring                |                       |

- \_\_\_\_\_ 1. A select type of soil used to support a pipe or other conduit in a trench.
- \_\_\_\_\_ 2. The gradual deterioration or destruction of a substance or material by chemical action, frequently induced by electrochemical processes. The action proceeds inward from the surface.
- \_\_\_\_\_ 3. The horizontal member of a shoring system, running parallel to the trench, to which the trench braces are attached. They hold the uprights against the soil.
- \_\_\_\_\_ 4. (a) A force resulting from water under pressure and in motion. This force pushes against fittings, valves and hydrants; it can cause couplings to leak or to pull apart entirely. (b) In general, any pushing force.
- \_\_\_\_\_ 5. The ability of a material to bend (flex) without breaking.
- \_\_\_\_\_ 6. The horizontal member of a shoring system that runs across a trench, attached to the stringer.
- \_\_\_\_\_ 7. A method of disinfecting new or repaired mains in which chlorine is continually added to the water being used to fill the pipe, so that a constant concentration can be maintained.
- \_\_\_\_\_ 8. A framework of wood and/or metal constructed against the walls of a trench to prevent cave-ins.
- \_\_\_\_\_ 9. Auxiliary equipment, such as valves and hydrants, attached to the distribution system to enable it to function properly.
- \_\_\_\_\_ 10. A method of disinfecting new or repaired water mains in which calcium hypochlorite tablets are placed in a section of pipe.
- \_\_\_\_\_ 11. Any pipe in the distribution system other than a service line.
- \_\_\_\_\_ 12. The horizontal centerline of a pipe.

- \_\_\_\_\_ 13. A number used in the Hazen-Williams formula, which is used to determine flow capacities of pipelines. It depends on the condition of the inside surface of the pipe. The smoother the surface of the pipe wall, the larger the number and the greater the carrying capacity of the pipeline.
- \_\_\_\_\_ 14. The pressure, expressed as feet of head or per unit of area (psi), exerted by water at rest (for example, in a nonflowing pipeline).
- \_\_\_\_\_ 15. A distribution system layout involving a complete loop of arterial mains around the area being served, with branch mains projecting inward to minimize dead ends.
- \_\_\_\_\_ 16. A method of disinfecting new or repaired water mains in which a high dosage of chlorine is added to a portion of the water used to fill the pipe. This water is allowed to pass through the entire length of pipe being disinfected.
- \_\_\_\_\_ 17. A distribution system layout in which all ends of the mains are connected to eliminate dead ends.
- \_\_\_\_\_ 18. A mass concrete cast in place between a fitting to be anchored against thrust and the undisturbed soil at the side or bottom of the pipe trench.
- \_\_\_\_\_ 19. Polyurethane foam plug, similar to pig but more flexible and less durable.
- \_\_\_\_\_ 20. The maximum angle or slope from the horizontal that a given loose or granular material, such as sand, can maintain without caving in or sliding; can vary considerably with changes in moisture content.
- \_\_\_\_\_ 21. The pipeline or aqueduct used for water transmission (from water plant to the distribution system).
- \_\_\_\_\_ 22. A method of preventing cave-ins by excavating the sides of the trench at an angle so the sides will be stable.
- \_\_\_\_\_ 23. A method to protect workers against cave-ins through the use of a steel box open at the top, bottom and ends, which allows the workers to work inside the box.
- \_\_\_\_\_ 24. A distribution system layout that centers around a single arterial main, which decreases in size with length. Branches are taken off at right angles with sub-branches from each branch.
- \_\_\_\_\_ 25. The ability of pipe or other material to resist breakage when pulled lengthwise.
- \_\_\_\_\_ 26. The load or force exerted by the water pressure on the inside of the pipe.
- \_\_\_\_\_ 27. Any load placed on the outside of the pipe from backfill, traffic, or other source.
- \_\_\_\_\_ 28. A block of concrete, often a roughly shaped cube, cast in place below a fitting to be anchored against vertical thrust, and tied to the fitting with anchor rods.
- \_\_\_\_\_ 29. The potentially damaging slam, bang, or shudder that occurs in a pipe when a sudden change in water velocity creates a great increase in water pressure.
- \_\_\_\_\_ 30. A momentary increase of water pressure in a pipeline due to a sudden change in water velocity or direction of flow.
- \_\_\_\_\_ 31. The vertical member of a shoring system, which is placed against the trench wall.



- \_\_\_\_\_ 32. That portion of the service line from the utility's water main to the curb stop at or adjacent to the street line or the customer's property line. It includes the curb stop and any other valves, fittings, etc., that the utility may require at or between the main and the curb stop, but does not include the curb box.
- \_\_\_\_\_ 33. Bullet-shaped polyurethane foam plug, often with a tough, abrasive external coating, used to clean pipelines. It is forced through the pipe by water pressure.

### Review Questions

1. List nine important points to be considered when pipe is to be strung at a jobsite.

- 
- 
- 
- 
- 
- 
- 
- 
- 

2. What eight factors usually determine the depth and width of a trench?

- 
- 
- 
- 
- 
- 
- 
- 

3. Why should wide trenches be avoided?

4. Name four danger signs that indicate potential trench failure.
  - 
  - 
  - 
  -
5. What is the angle of repose of soil and why is it important?
6. List five typical causes of trench cave-ins.
  - 
  - 
  - 
  - 
  -
7. Why is the proper placement of bedding material important?
8. Explain why thrust blocks and anchors are important. Where should they be used?
9. What type of distribution system configuration is not recommended? Why?
10. What can happen if a valve is opened or closed too quickly?
11. Explain what is meant by the C value of a pipe.

12. List seven unusual pipe installation conditions that might have a bearing on the type of pipe used for a particular installation.

- 
- 
- 
- 
- 
- 
- 

13. List some advantages and disadvantages of ductile-iron pipe.

14. List some advantages and disadvantages of PVC pipe.

## Answers to Vocabulary:

- |       |        |        |
|-------|--------|--------|
| 1. D  | 12. T  | 23. P  |
| 2. F  | 13. G  | 24. DD |
| 3. U  | 14. L  | 25. Y  |
| 4. Z  | 15. C  | 26. M  |
| 5. J  | 16. S  | 27. I  |
| 6. EE | 17. K  | 28. AA |
| 7. E  | 18. BB | 29. GG |
| 8. Q  | 19. W  | 30. V  |
| 9. B  | 20. A  | 31. FF |
| 10. X | 21. CC | 32. O  |
| 11. H | 22. R  | 33. N  |

## Answers to Review Questions:

1.
  - Lay or place pipe as near to the trench as possible to avoid excessive handling.
  - If the trench is open, string pipe on the side opposite the spoil bank.
  - If the trench is not open, string pipe along the side of the trench opposite the side where excavated material will be placed.
  - Place pipe where it will be protected from traffic and heavy equipment.
  - Place the bells in the direction of installation progress.
  - Place and secure each pipe so there is no chance of it rolling into the trench.
  - String only enough pipe for one day if there is danger of vandalism.
  - Be aware of the danger of children injuring themselves playing around a strung pipe.
  - Cover the ends of a pipe if there is danger of it becoming contaminated.
  
2.
  - Ground frost conditions
  - Groundwater conditions
  - Traffic load that will be over the pipe
  - Soil type
  - Type of pipe to be installed
  - Economics
  - Surface restoration requirements
  - Depth of other adjacent utilities
  
3. They are more expensive to excavate and the load on the pipe can be considerably increased.

4.
  - Tension cracks in the ground surface parallel to the trench
  - Material crumbling off the walls
  - Settling or slumping of the ground near the trench
  - Sudden changes in soil color indicating previous excavation
5. The angle of repose is the angle at which the trench wall should be excavated to prevent cave-ins (unless shoring is used). The angle varies depending on the type of earth material being excavated.
6.
  - Water pressure in the soil
  - External loads, such as equipment being moved close to the edge of the trench
  - The load of excavated soil stacked too closely to the edge of the trench
  - Trench walls excavated too steeply for the type of soil conditions
  - Cleavage planes in the soil caused by previous excavations
7. The pipe must be supported uniformly along its entire length or else breakage can occur when loads are imposed by backfill or traffic.
8. Thrust blocks and anchors are required to restrain joints from opening as a result of the force created when water changes direction. They should be used where flow will change direction at elbows, tees and crosses; where there is a change in pipe diameter; and wherever flow stops or is controlled, such as at valves and dead ends.
9. The tree-type system is not recommended because only a few loops are formed. This arrangement restricts circulation, making it difficult to supply a continuous flow of good-quality water to all parts of the system.
10. Water hammer may result from opening or closing a valve quickly. The increased pressure could then result in broken mains or water services, or it could cause fire hydrants to be pushed out of place if they are not firmly blocked.
11. The C value is an indication of how easily water can move through a pipe. A pipe with a very smooth interior will have a high C value. A pipe with rough interior walls will have a low value.
12. Unusual soil conditions
  - Uneven terrain
  - High groundwater
  - High bedrock
  - A river or highway crossing
  - Proximity to sewer lines
  - Close proximity to other utility services

13. Advantages: good durability, flexural strength, smooth interior (C140), carry capacity, fracture resistance, external corrosion good in most soils, withstand high pressure, long term economical, diversity when combined with different fittings, joints, and valves

Disadvantages: external corrosion in aggressive environments if not protected, reliant upon special linings to protect against corrosion, costly to maintain, greater weight increases difficulty of installation

14. Advantages: lower cost, cheaper to ship, easier to handle, cuts easier, C Factor less than 150, chemically inert, moderately flexible and will adapt to ground settling

Disadvantages: susceptible to damage from UV, permeable by organics, requires careful bedding to prevent damage, difficult to locate because nonconductive, inability to be thawed, buckles under a vacuum, must adhere to use of proper tools and procedures when service taps are made

## **Section 3**

### **Valves**



# Valves

- CSUS: Water Distribution System
- AWWA: Water Transmission and Distribution

## Objectives

- Valve Classifications
  - Linear Operation Valves
  - Rotary Operation Valves
- Valve Operation
- Valve Boxes & Vaults

# Valve Classifications





## Valve Uses

- Start and stop flow
- Isolate piping
- Regulate pressure and throttle flow
- Prevent backflow
- Relieve pressure

# Valves

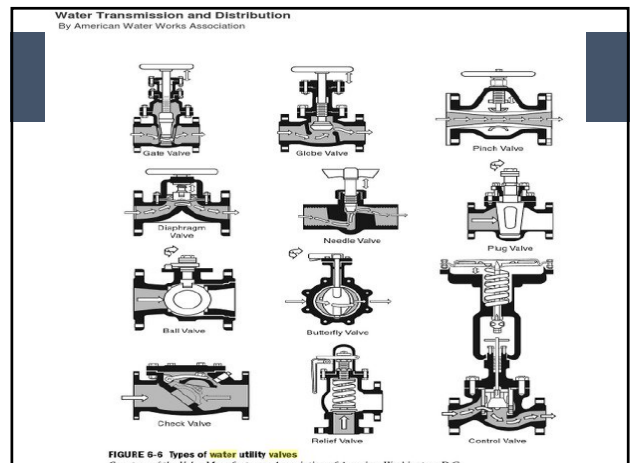
- Distribution Isolation Valves
  - Hydrant auxiliary valves
  - Pump control valves
  - Water service valves
- Valves for regulating pressure and throttling flow
  - Pressure reducing valves
  - Altitude valves
    - Single-acting
    - Double-acting
- Valves for Relieving Pressure
  - Pressure-relief valves
  - Air-relief valves





## Linear Valves vs Rotary Valves

- In general, valves may be classified as
  - Linear Operation
    - Stem must turn several times to move closure element up or down from a fully open to fully closed position
    - Includes diaphragm, globe, gate, and check valves
  - Rotary Operation
    - Stem moves from fully open to fully closed position by rotating 90 degrees without linear (up-and-down) motion
    - Includes plug, ball, and butterfly

## Valve Classification

- Gate valves
- Globe valves
- Needle valves
- Pressure-relief valves
- Air-and-vacuum relief valves
- Diaphragm valves
- Pinch valves
- Rotary valves
- Butterfly valves
- Check valves

## Gate Valve

- Most common type of valve
- Gate or disk of valve is raised or lowered by a screw, which is operated by a handwheel or valve key
- Unrestricted flow when fully open
- Should not be used to throttle flow
  - Will cause gate mechanism to vibrate and be damaged
- Not designed for frequent use

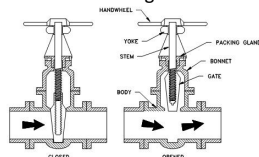

## Gate Valves – Rising Stem

- Upper part of the stem is threaded
- A yoke nut moves the stem up and down as the handwheel turns at right angles to the flow
- Used where it is needed to be able to look ok at position of the screw to know if open or closed
- Should not be used where dirt may get into the screw

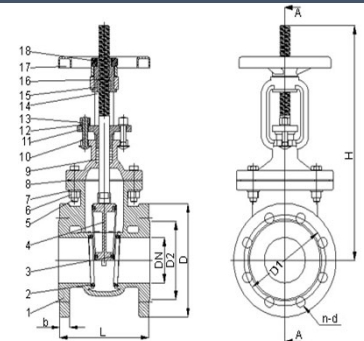

## Gate Valves – Nonrising Stem

- Most common in distribution system
- Lower end of the stem is threaded & screws into the disk
- The disk moves up or down while a thrust collar keeps the stem in place
- Functions best when fully open or fully closed

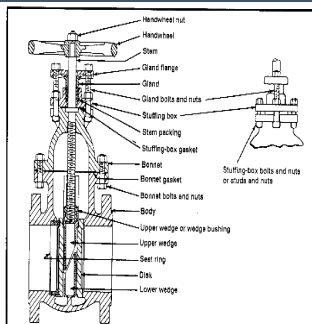

Figure 2-5. Nonrising-stem gate valve

## Gate Valves in the Distribution System

Generally used to isolate sections of the system

- **Hydrant Auxiliary Valve** – direct connection to a fire hydrant
- **Tapping Valves** – connection to a tapping tee & connection to tapping machine
- **Horizontal Gate Valves** – used in large diameter pipe and designed to lie on one side
- **Bypass Valves** – included in large gate valves

### Gate Valves

- Nonrising-stem gate valve
- Rising-stem gate valve
- Horizontal gate valve
- Bypass valve
- Tapping valves
- Cutting-in valves
- Inserting valves
- Resilient-seated gate valves
- Slide valves

### Valve Classification

- **Globe Valves**
  - Require little maintenance
  - Disc and seat can be replaced or restarted quickly and easily
  - Relatively high head loss when fully open
  - Suitable for service in **small** pipelines only
- **Needle Valves**
  - Tapered metal shaft that fits into a metal seat
  - Installed on hydraulic lines to valve actuators

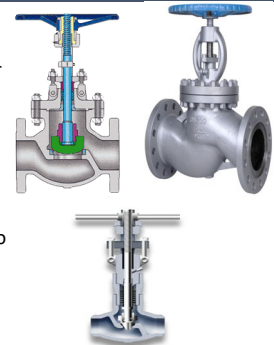

### Pressure Relief Valves

- Valve stem raises or lowers a disc onto a seat
- Globe Valve with an adjustable spring to maintain pressure on the valve seat to keep the valve closed under normal pressure conditions
- Used to prevent damage from water hammer

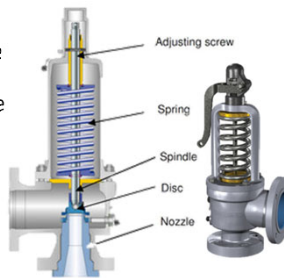

### Valve Classification

- **Diaphragm Valves**
  - Pressure exerted on diaphragm used to close the valve
  - Altitude valve
- **Pinch Valves**
  - Closed by pinching a flexible interior lining
  - Useful for throttling flow in corrosive waters

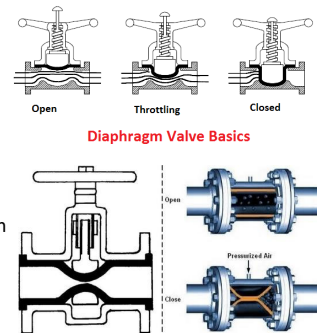

### Altitude Valves

- Ground level reservoirs are usually filled through an altitude valve
- Allows water to fill a reservoir at a controlled rate
- Activated by the water pressure from the reservoir to close automatically when the reservoir is full
- Also controls flow to elevated tanks

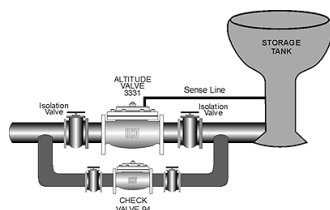

### Air and Vacuum Relief Valves

- Float operated valve that allows air to escape when the float is down
- Commonly used on the discharge of a well pump
- Should be installed at high points in transmission pipelines

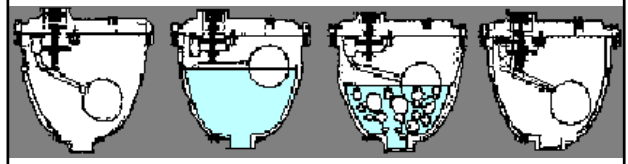

### Pressure Reducing Valves

- Operate automatically to throttle flow and maintain a lower pressure
- Valve has 2 upper operating chambers sealed from each other by a flexible reinforced diaphragm
- The chambers receive pressure from the system and are adjusted to modulate the valve stem up and down to maintain the desired discharge pressure

### Pressure Reducing Valves

### Valve Classification

- Rotary Valves
  - Requires ¼ turn to fully open or fully close
  - Commonly used as curb stops or corporation stops
  - Can be used to throttle flow without damage
- Plug Valve
  - Cylinder or cone shaped plug has passageway through it
- Ball Valve
  - Similar to plug valve with operating element being a sphere

### Valve Classification

- Butterfly Valves
  - Disk rotates on a shaft to open or close valve
  - Even fully open, pressure loss will occur
  - Easily and quickly operated – beware water hammer
  - Often leak due to seat damage
- Check Valves
  - Allow flow in only one direction
  - Foot valve installed at bottom of pump suction to hold prime
  - Can cause water hammer is allowed to close unrestrained
    - External weights, restraining springs, automatic slow-closing motorized devices
  - Includes backflow prevention devices

### Types of Linear Valves & Throttling Capabilities

<ul style="list-style-type: none"> <li>➤ Gate valve – do not throttle</li> <li>➤ Globe valve – very efficient for flow or pressure regulation</li> <li>➤ Needle valve – used for precise throttling of flow</li> </ul>	}	Example: Pressure reducing valves
<ul style="list-style-type: none"> <li>➤ Diaphragm valve – throttling not mentioned</li> <li>➤ Pinch valve – throttling not mentioned</li> </ul>	}	Example: Altitude valves
<ul style="list-style-type: none"> <li>➤ Check valve – does not throttle</li> </ul>		

### Types of Rotary Valves & Throttling Capabilities

- Ball valve – should be operated fully open or fully closed
- Plug valve – may be used for throttling flow without damage
- Butterfly valve – can be used for low-pressure, low-flow conditions



### Valve Operation

- **Manual**
  - Usually with a handwheel, chainwheel or floor stand operator
  - Buried valves fitted with 2 inch square operating nut
- **Actuators – device designed to power-operate the closure element of a valve**
  - **Electric actuators**
    - Small electric motor rotates valve stem through gear box
    - Operates until turned off by limit switch when valve is fully open or closed



### Valve Operation

- **Actuators**
  - **Hydraulic actuators**
    - Use either system water pressure or hydraulic fluid
    - Valve stem connected to piston in closed chamber
    - Water under pressure enters chamber below piston lifting the piston and opening valve
    - Should have separate pressure system with back up pressure tank
  - **Pneumatic actuators**
    - Operate similar to hydraulic actuators only using air instead of liquid
    - Commonly used on control valves

### Valve Boxes and Vaults

- **Provide access to buried valves**
  - Valve box placed over valve
  - Valve vault built around valve
- **Operating nut must be accessible with a valve key from the surface through an access cover**
- **Vaults should not put weight or pressure on water main**
- **Vault should have a drain**
  - Should not be connected to storm drain or sewer due to potential of backflow
- **Confined space so take appropriate precautions**

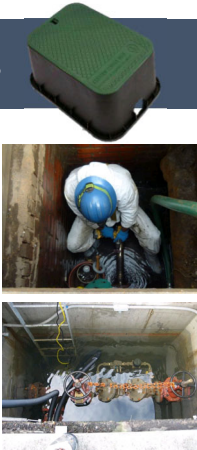

### Valves

- **Storage**
  - Store indoors preferably
  - If stored outside, protect actuators, cylinders, valve ports and flanges from weather
  - Store vertically to prevent rainwater collecting on top of disk and freezing
- **Record Keeping**
  - Location including measurement from 3 different permanent objects
  - Make, size, date of installation, type of valve

## Valve Vocabulary

A. Actuator	R. Inserting valve
B. Air-and-vacuum relief valve	S. Isolation valve
C. Air binding	T. Nonrising-stem valve
D. Air-relief valve	U. Packing
E. Altitude-control valve	V. Plug valve
F. Backflow	W. Pressure-reducing valve
G. Ball valve	X. Pressure-relief valve
H. Butterfly valve	Y. Resilient-seated gate valve
I. Bypass valve	Z. Seat
J. Check valve	AA. Service valve
K. Corporation stop	BB. Tapping valve
L. Curb box	CC. Valve
M. Curb stop	DD. Valve box
N. Cut-in valve	EE. Valve key
O. Floorstand	FF. Vault
P. Gate valve	GG. Water hammer
Q. Globe valve	

- \_\_\_\_\_ 1. A valve for joining a service line to a street water main. It can't be operated from the surface. Also called a corporation cock.
- \_\_\_\_\_ 2. A valve that automatically shuts off water flow when the water level in an elevated tank reaches a preset elevation then opens again when the pressure on the system side is less than that on the tank side.
- \_\_\_\_\_ 3. A valve installed in a pipeline to shut off flow in a portion of the pipe, for the purpose of inspection or repair. Such valves are usually installed in the main lines.
- \_\_\_\_\_ 4. A gate valve with a disc that has a resilient material attached to it, to allow a leak-tight shutoff at high pressures.
- \_\_\_\_\_ 5. A specially designed valve used with a sleeve that allows it to be placed in an existing main.
- \_\_\_\_\_ 6. A special shut-off valve used with a tapping sleeve.
- \_\_\_\_\_ 7. A device, usually electrically or pneumatically powered, that is used to operate valves.
- \_\_\_\_\_ 8. A metal or concrete box or vault set over a valve stem at ground surface to allow access to the stem so the valve can be opened and closed.
- \_\_\_\_\_ 9. An underground structure, normally made of concrete, that houses valves and other appurtenances.
- \_\_\_\_\_ 10. A gate valve in which the valve stem does not move up and down as it is rotated.
- \_\_\_\_\_ 11. A shutoff valve attached to a water service line from a water main to a customer's premises, usually placed near the customer's property line. Also called a curb cock.

- \_\_\_\_\_ 12. A valve in which the closing element consists of a disc that slides across an opening to stop the flow of water.
- \_\_\_\_\_ 13. A hydraulic condition, caused by a difference in pressures, in which nonpotable water or other fluids flow into a potable water system.
- \_\_\_\_\_ 14. A dual-function air valve that (1) permits entrance of air into a pipe being emptied, to prevent a vacuum, and (2) allows air to escape in a pipe being filled or under pressure.
- \_\_\_\_\_ 15. The portion of a valve that the disc compresses against to achieve shutoff of the water.
- \_\_\_\_\_ 16. The potentially damaging slam, bang or shudder that occurs in a pipe when a sudden change in water velocity creates a great increase in water pressure.
- \_\_\_\_\_ 17. A valve in which the movable element is a cylindrical or conical plug.
- \_\_\_\_\_ 18. A shutoff valve that can be inserted by special apparatus into a pipeline while the line is in service under pressure.
- \_\_\_\_\_ 19. The condition in which air has collected in the high points of distribution mains, reducing the capacity of the mains.
- \_\_\_\_\_ 20. A cylinder placed around the curb stop and extending to the ground surface to allow access to the valve.
- \_\_\_\_\_ 21. A valve in which the disc rotates on a shaft as it opens or closes. In the full open position, the disc is parallel to the axis of the pipe.
- \_\_\_\_\_ 22. Any valve that is used to shut off water to individual customers.
- \_\_\_\_\_ 23. A metal wrench with a socket to fit a valve operating nut.
- \_\_\_\_\_ 24. A valve that opens automatically when the water pressure reaches a preset limit, to relieve the stress on a pipeline.
- \_\_\_\_\_ 25. A mechanical device installed in a pipeline to control the amount and direction of water flow.
- \_\_\_\_\_ 26. A valve designed to open in the direction of normal flow and close with reversal of flow. An approved check valve is of substantial construction and suitable materials, is positive in closing and permits no leakage in a direction opposite to normal flow.
- \_\_\_\_\_ 27. An air valve placed at a high point in a pipeline to release air automatically, thereby preventing air binding and pressure buildup.
- \_\_\_\_\_ 28. A small valve installed in parallel with a larger valve; it is used to equalize the pressure on both sides of the disc of the larger valve before the larger valve is opened.
- \_\_\_\_\_ 29. A device for operating a gate valve (by hand) and indicating the extent of opening.
- \_\_\_\_\_ 30. Rings of graphite impregnated cotton, flax, or synthetic material, used to control leakage along a valve stem.
- \_\_\_\_\_ 31. A valve having a round, ball-like shell and horizontal disc.
- \_\_\_\_\_ 32. A valve with horizontal disc for reducing water pressures in a main automatically to a preset value.
- \_\_\_\_\_ 33. A valve consisting of a ball resting in a cylindrical seat. A hole is bored through the ball to allow water to flow when the valve is open; when the ball is rotated 90°, the valve is closed.

## Review Questions

1. List six uses for valves in a water distribution system.
  - 
  - 
  - 
  - 
  - 
  -
2. For each valve use listed in question 1, name one valve type suitable for that use.
  - 
  - 
  - 
  - 
  - 
  -
3. List the three most common types of joints used to install valves.
  - 
  - 
  -
4. What is the primary purpose of a bypass valve?
5. How often should distribution system isolation valves be operated or inspected?
6. What can happen if a valve is opened or closed too quickly?

7. List at least three items to check during routine inspection of a valve.

- 
- 
- 

## Answers

### Vocabulary:

- |       |        |        |
|-------|--------|--------|
| 1. K  | 12. P  | 23. EE |
| 2. E  | 13. F  | 24. X  |
| 3. S  | 14. B  | 25. CC |
| 4. Y  | 15. Z  | 26. J  |
| 5. N  | 16. GG | 27. D  |
| 6. BB | 17. V  | 28. I  |
| 7. A  | 18. R  | 29. O  |
| 8. DD | 19. C  | 30. U  |
| 9. FF | 20. L  | 31. Q  |
| 10. T | 21. H  | 32. W  |
| 11. M | 22. AA | 33. G  |

### Review Questions:

1. isolation, draining lines, throttling flow, regulating water-storage levels, controlling water hammer, bleeding off air and allowing air into lines, and preventing backflow
2. isolation: gate, butterfly, globe, plug, ball  
 drain: blow-off  
 throttle: butterfly, plug, globe, ball  
 regulate storage levels: altitude-control valve  
 control water hammer: pressure-relief valve  
 allow air in and out of lines: air-relief valve  
 control backflow: check valve
3. flanged, mechanical, push-on
4. To help equalize pressure on a large valve, making it easier to open and close.
5. annually at least; more often for important valves
6. water hammer
7. location measurements; whether found open or closed; condition of packing, stem, operating nut, gears (if any), box or vault, box cover; number of turns to open and close



**Section 4**  
**Water Stability**



# Stabilization

➤ Corrosion and Scaling Control in the Distribution System

## Objectives

- Stabilization and Its Purpose
- Corrosion
- Scale Formation
- Control Methods

## Stabilization

- The process for controlling corrosion and scale deposits on pipelines and plumbing fixtures.
- Corrosion and scale deposits in the distribution system can be very costly for utility.
- Problems range from excessive customer complaints to increased pumping costs, to replacement of mains due to leaks and breaks.
- Corrosion control is also important in protecting consumers from the dangers of excess lead and copper.

## Purpose of Stabilization

- 1 To protect public health
  - Corrosive water can leach toxic metals from distribution piping and household plumbing - lead and copper
  - Corrosion of cast-iron mains causes tubercles (iron deposits) that can protect bacteria from chlorine, allowing them to grow and thrive

## Purpose of Stabilization

- 2 To improve water quality
  - Corrosive water attacking metal pipes can cause color, taste & odor problems
  - Red-water from cast-iron mains
    - the iron will stain a customer's plumbing fixtures and laundry and make the water's appearance unappealing for drinking and bathing
  - Corrosion of copper pipes can cause metallic taste and blue-green stains on plumbing fixtures and laundry

## Purpose of Stabilization

- 3 To extend life of plumbing equipment
  - Aggressive water reduces life of valves, unprotected metal, asbestos-cement pipe, plumbing fixtures, water heaters
  - Buildup of scale and corrosion products reduces capacity of pipes, which reduces distribution system efficiency and increases pumping costs
  - If scale deposits go unchecked, pipes can become completely plugged

## Purpose of Stabilization

- 4 To meet federal and state regulations
  - Lead and Copper Rule - 1991
  - Systems must check if their water is corrosive enough to cause lead and copper to be present
  - Samples taken at high-risk locations; homes with lead pipes, service lines or lead solder

## Lead & Copper Rule (LCR)

- Samples are to be collected after water has sat in lines for at least 6 hours - first draw
- 1 liter taken from cold water tap in kitchen or bathroom
- Action level for lead is 0.015 mg/L, copper is 1.3 mg/L
- If a system exceeds action level in more than 10% of samples, must take steps to control corrosion

## Corrosion



- Definition of Corrosion
- Factors Affecting Corrosion
- Types of Corrosion

## Water System Corrosion

- Corrosion - the gradual deterioration or destruction of a substance or material by chemical reaction with the water
- Water that promotes corrosion is called corrosive or aggressive water



## Factors that Affect Corrosivity of Water

- Dissolved Oxygen
  - as dissolved oxygen increases, rate of corrosion increases
- Total Dissolved Solids
  - increase electrical conductivity of water
- Alkalinity
  - buffers a change in pH, decreases corrosion
- pH
  - low pH promotes corrosion, high pH can be scale-forming
- Hardness
  - a small amount can form protective layer of scale on pipes to prevent corrosion

## Factors that Affect Corrosivity of Water

- Temperature
  - corrosion occurs faster in warmer waters
- Flow Velocity
  - increased velocity can increase rate of corrosion if water is corrosive
  - increased velocity can decrease rate of corrosion if adding corrosion inhibitor
- Type of metals
  - galvanic corrosion is corrosion of dissimilar metals
- Electrical Current
  - improperly grounded household electrical systems can accelerate corrosion
  - electric railway systems can be a cause of this also

### Factors that Affect Corrosivity of Water

- H<sub>2</sub>S gas released
  - Causes rotten egg odor
  - Can react with water to form H<sub>2</sub>SO<sub>4</sub>, which is highly corrosive
  - Produce black sulfide deposits
- Iron Bacteria (*Gallionella*)
  - Convert dissolved iron into precipitate causing red-water complaints
  - Produce slime which protects against chlorine and prevents accumulation of CaCO<sub>3</sub>
  - Bacteria can slough off causing tastes & odors
  - Bacteria can change pH and alkalinity of water as they give off gases, mainly CO<sub>2</sub>
- Under anaerobic conditions, corrosion can be accelerated by iron bacteria or sulfate-reducing bacteria

### External Pipeline Corrosion

- Soil surrounding pipe can cause external corrosion
- A-C, concrete, CIP & DIP susceptible only in aggressive soil conditions
- Steel pipe should be well coated and have cathodic protection in all soil conditions
- Corrosion can lead to leakage, breaks, and shortened service life
- Corrosion takes form of pits on pipe surface that may ultimately penetrate pipe wall
  - Occurs on steel, cast-iron, and ductile-iron

### Factors Affecting External Corrosion

- High moisture content
- Poor aeration
- Fine texture
- Low electrical resistivity
- High organic material content
- High chloride or sulfate content
  - Increases conductivity
- High acidity or alkalinity
- Presence of sulfide
- Presence of anaerobic bacteria



### Methods of Prevention

- Specifying extra thickness for pipe walls
  - Short term remedy
- Applying protective coating
  - Coated pipe must be inspected and handled carefully
- Wrapping pipe in polyethylene plastic sleeves
  - Care must be taken when tapping pipe to not expose bare metal
- Installing cathodic protection on pipe
  - Principal means are sacrificial anodes and impressed-current systems

### Types of Corrosion

- Localized Corrosion
  - Most common, most serious
  - Attacks surface unevenly, leads to rapid failure of metal
  - Two types
    - Galvanic (bimetallic) corrosion
    - Concentration cell corrosion
- Uniform Corrosion
  - Occurs evenly over all surface
  - Due to low pH and alkalinity

### Localized Corrosion Examples



### Types of Corrosion

- **Bimetallic Corrosion**
  - aka Galvanic corrosion
  - Occurs when two electrochemically dissimilar metals are directly connected to each other
  - A form of localized corrosion caused by the connection of two dissimilar metals in an electrolyte, such as water
    - Example: brass fitting to galvanized iron pipe
  - Coatings and insulators are most common methods of corrosion control
- **Stray-current Corrosion**
  - Caused by DC current that collects on a pipeline and discharges into soil
  - Appears as deep pits concentrated in a small area on the pipe

### Localized Corrosion

Sink hole caused by 8-in main break

### Galvanic Series of Metals

<b>Corroded End (anode)</b>		<b>Most Active</b>
Magnesium		+
Magnesium alloys		
Zinc		
Aluminum		
Mild Steel		
Wrought (black) Iron		
Cast Iron		
Lead-tin Solders		
Lead		
Tin		
Brass		
Copper		
Stainless Steel		
<b>Protected End (cathode)</b>		<b>Least Active</b>

Corrosion Potential

### Cathodic Protection (CP) Methods

#### Sacrificial Anode CP Method

$Mg \rightarrow Mg^{2+} + 2e^-$

$\frac{1}{2} O_2 + H_2O + 2e^- \rightarrow 2OH^-$

Protected Aluminum structure

$E_{SCE, Mg}^{0.1\% NaCl} = -1.55$  V vs. SCE (in 0.1 wt% NaCl solution)  
 $E_{SCE, Al_{0.004}}^{0.1\% NaCl} = -0.6$  V vs. SCE (in 0.1 wt% NaCl solution)

#### Impressed Current CP Method

DC Power Source

Protected Aluminum Structure

### Cathodic Protection

- **Sacrificial anodes**
  - Magnesium-alloy or zinc castings connected to pipe
- **Impressed current systems**
  - External source of DC power that makes pipe/tank cathodic
    - Rectifiers convert AC to DC

### Process of Galvanic Corrosion



**A. Minor variations cause electric current to develop**  
 $H_2O \rightleftharpoons H^+ + OH^-$   
 $2H^+ + 2e^- \rightarrow H_2 \uparrow$  (Cathode)

**B. Chemical reactions in water balance those in iron**  
 $Fe^{2+} + 2OH^- \rightarrow Fe(OH)_2$  (Anode)

**C. Rate of corrosion is accelerated**  
 $H_2O_2 + 2H^+ + 2e^- \rightarrow 2H_2O$  (Cathode)

**D. Rust forms**  
 $Fe(OH)_2 + 2H^+ \rightarrow Fe(OH)_3 + H_2O$  (Anode)

## Scale Formation

- Definition of Scale Formation
- Factors Affecting Scale Formation
- Types of Scale Formation

## Scale Formation

- Scale formation - the precipitation of certain hardness-causing ions with other minerals to form a coating on pipe walls
- The formation of a small amount of scale can help protect the pipe from corrosion
- Uncontrolled deposits reduce the carrying capacity of the pipe
- Can also decrease the efficiency of boilers, water heaters, etc

## Scale-forming Compounds

- $\text{CaCO}_3$  – Calcium carbonate
- $\text{MgCO}_3$  – Magnesium carbonate
- $\text{CaSO}_4$  – Calcium sulfate
- $\text{MgCl}_2$  – Magnesium chloride



## Scale Formation

- Saturation point - the point at which a solution can no longer dissolve any more of a particular chemical; precipitation of the chemical will occur past this point
- Solubility varies with temp, pH, TDS, etc
- Solubility of  $\text{CaCO}_3$  in water decreases as temperature increases; the higher temperature in water heaters causes  $\text{CaCO}_3$  to precipitate out and build up on pipe, tank walls and heating element

## Stabilization Control Methods



Corrosive  
Water
Stable  
water
Scale-  
Forming

**Water is considered stable when it is just saturated with calcium carbonate.**  
**It will neither deposit nor dissolve calcium carbonate.**

### Control Methods

- 1 pH and alkalinity adjustment
- 2 Formation of  $\text{CaCO}_3$  coating
- 3 Use of corrosion inhibitors and sequestering agents

### pH and Alkalinity Adjustment

- Soft waters with pH less than 7 and poorly buffered (low alkalinity) will be corrosive to lead and copper
- Water with too much alkalinity can also be corrosive
- A moderate increase in pH and alkalinity can reduce corrosion
- A moderate decrease in pH and alkalinity can prevent scale formation

### Formation of $\text{CaCO}_3$ Coating

- A protective coating on pipe surfaces can inhibit corrosion.
  - Lime, alone or in combo with soda ash or sodium bicarb, can be added to precipitate a  $\text{CaCO}_3$  scale on the pipe walls
  - A coating of cement, epoxy, etc. can be applied to interior pipe surfaces.
  - Phosphates and sodium silicate can be used for corrosion control and stabilization.

### Phosphates as Corrosion Inhibitors

- Polyphosphates work as sequestering agents
  - Tie up iron and manganese to prevent color and taste complaints
  - Also tie up calcium carbonate to prevent excess scale
  - Calcium (from alkalinity) is required as a catalyst
  - If low alkalinity, need to feed a blend of polyphosphate and orthophosphate
- Orthophosphates work well for lead and copper protection
- Orthophosphate coats pipe, polyphosphate sequesters

### Phosphates

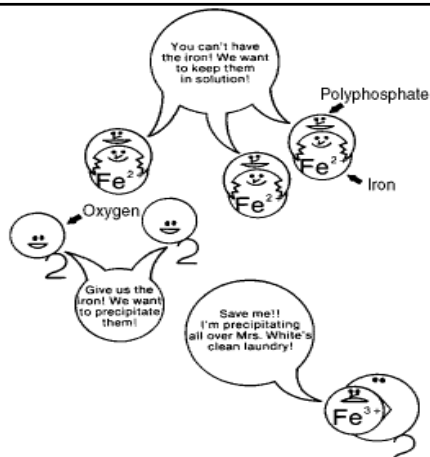

### Stabilization Evaluation

- In the distribution system:
  - Evaluate effects of corrosion and scaling
  - Records of main breaks and leaks - corrosion
  - Info on how well older valves operate - if difficult to operate, may be coated with scale
  - Info on reduced flow rates in mains - buildup of scale
  - When possible, pieces or sections of pipe removed should be tagged and evaluated.

## Stabilization Evaluation

- In customers' plumbing:
  - Customer complaints
    - Red water, brown water, loss of pressure
    - Location where problems occur
    - Time of year
- For meeting regulation requirements:
  - Lead and Copper Rule
    - Must take steps to reduce corrosion if action levels are exceeded

## Stabilization Evaluation

- Water quality data:
  - Determine if there is an increase in metals in distribution system (copper, zinc, cadmium)
  - Before initiating a corrosion control program, check with others in the field who can give sound advice.
  - Using the wrong stabilization method can increase problems

## Operational Controls

- Water quality analyses
  - Lab data for calculating Langelier Saturation Index (LSI)
- In-plant monitoring
  - Continuously recording pH meter
- Distribution system monitoring
  - Check for presence of metals indicating corrosion
- Pipe and coupon testing
  - Small section of metal is placed in a pipe, checked for corrosion or scaling

## Coupon Testing

- Measures the effects of the water on a small section of metal (the coupon) inserted in a water line.
- After a minimum of 120 days, the inserts are removed, cleaned, weighed and examined.
- The weight loss or gain of the coupon can provide an indication of the corrosion or scaling rate.

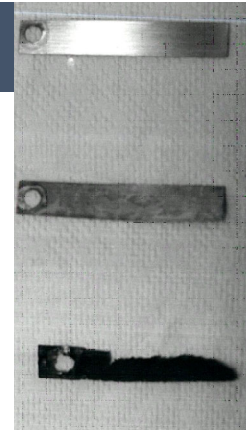

## Records

- Amount of chemicals used - state report
- Lab tests, Langelier Saturation Index calculations
- Maintenance records
- Results of coupon tests and other tests
- Customer complaints related to corrosion or scaling
  - Note location and time of year



## Corrosion Vocabulary

- |                                 |                        |
|---------------------------------|------------------------|
| A. Aggressive                   | L. Localized Corrosion |
| B. Anode                        | M. Milk of Lime        |
| C. Cathode                      | N. Red Water           |
| D. Concentration Cell Corrosion | O. Saturation Point    |
| E. Corrosion                    | P. Sequestering Agent  |
| F. Corrosive                    | Q. Slaker              |
| G. Coupon Test                  | R. Stabilization       |
| H. Galvanic Corrosion           | S. Tubercules          |
| I. Galvanic Series              | T. Uniform Corrosion   |
| J. Iron Bacteria                | U. Unstable            |
| K. Langlier Index               |                        |

- \_\_\_\_\_ 1. A chemical compound such as EDTA or certain polymers chemically tie up other compounds or ions so they can't be involved in chemical reactions.
- \_\_\_\_\_ 2. To deteriorate material, such as pipe, through electrochemical processes.
- \_\_\_\_\_ 3. Bacteria that use dissolved iron as an energy source.
- \_\_\_\_\_ 4. The lime slurry formed when water is mixed with calcium hydroxide.
- \_\_\_\_\_ 5. Knobs of rust formed on the interior of cast iron pipes due to corrosion.
- \_\_\_\_\_ 6. Corrosive.
- \_\_\_\_\_ 7. A term used to describe rust-colored water due to the formation of ferric hydroxide from iron naturally dissolved in the water or as a result of the action of iron bacteria.
- \_\_\_\_\_ 8. A listing of metals and alloys according to their corrosion potential.
- \_\_\_\_\_ 9. To be corrosive or scale-forming.
- \_\_\_\_\_ 10. Positive end (pole) of an electrolytic system.
- \_\_\_\_\_ 11. The point at which a solution can dissolve no more of a particular material.
- \_\_\_\_\_ 12. A numerical index that indicates whether calcium carbonate will be deposited or dissolved in a distribution system.
- \_\_\_\_\_ 13. The water treatment process intended to reduce the corrosive or scale-forming tendencies of water.
- \_\_\_\_\_ 14. Negative end (pole) of an electrolytic system.
- \_\_\_\_\_ 15. A form of localized corrosion that can form deep pits or tubercules.
- \_\_\_\_\_ 16. A form of corrosion that attacks a small area.
- \_\_\_\_\_ 17. The part of the quicklime feeder that mixes the quicklime with water to form hydrated lime.
- \_\_\_\_\_ 18. A form of localized corrosion caused by the connection of dissimilar metals in an electrolyte such as water.
- \_\_\_\_\_ 19. The gradual deterioration or destruction of a substance or material by chemical reaction. The action proceeds inward from the surface.
- \_\_\_\_\_ 20. A form of corrosion that attacks material at the same rate over the entire area of its surface.
- \_\_\_\_\_ 21. A method of determining the rate of corrosion or scale formation by placing metal strips of a known weight in the pipe.

### Answers to Corrosion Vocabulary

- |      |       |       |
|------|-------|-------|
| 1. P | 8. I  | 15. D |
| 2. F | 9. U  | 16. L |
| 3. J | 10. B | 17. Q |
| 4. M | 11. O | 18. H |
| 5. S | 12. K | 19. E |
| 6. A | 13. R | 20. T |
| 7. N | 14. C | 21. G |

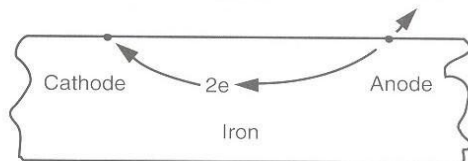

A. Minor variations cause electric current to develop

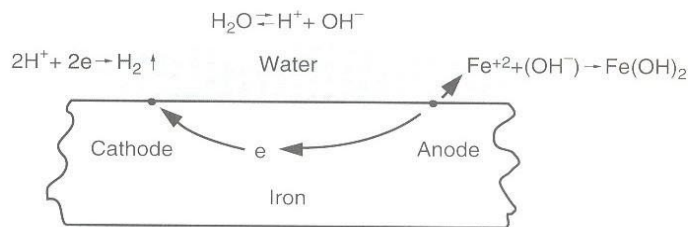

B. Chemical reactions in water balance those in iron

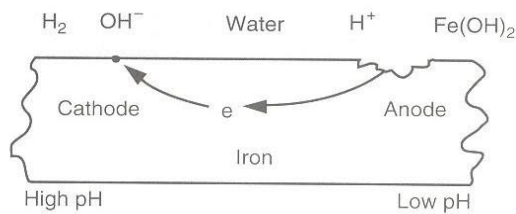

C. Rate of corrosion is accelerated

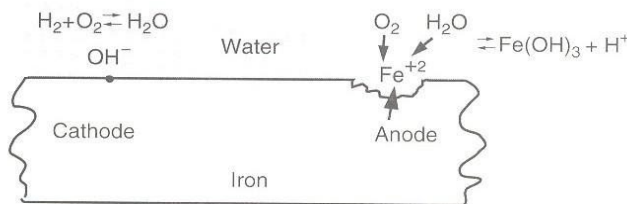

D. Rust forms

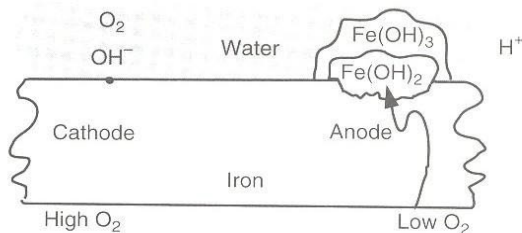

**Section 5**  
**Storage Tanks**



## Storage Tanks



- CSUS: Water Distribution Systems
- AWWA: Water Transmission and Distribution

## Objectives

- Water Storage
- Water Storage Tanks
- Operation and Maintenance
- System Operations



## Water Storage





## Purpose of Water Storage

- Equalizing supply and demand
- Increasing operating convenience
- Leveling out pumping requirements
- Decreasing power costs



## Purpose of Water Storage



- Providing water during power or pump failure
- Providing adequate water for fire fighting
- Providing surge relief
- Increasing detention times
- Blending water sources
- Decrease pumping costs

## Capacity Requirements

- Based on maximum water demands in different parts of the system
- Too much storage can cause stagnant water and taste & odor problems
  - 20% turnover rate to prevent it from becoming septic within 24 hours
    - less sediment

### Type of Service

- Operating Storage
  - Tank directly connected to distribution piping
  - Fills and empties based on system pressure
- Emergency Storage
  - Used for emergency, e.g. fire protection
  - Not suitable for potable use
  - Subject to freezing due to lack of circulation

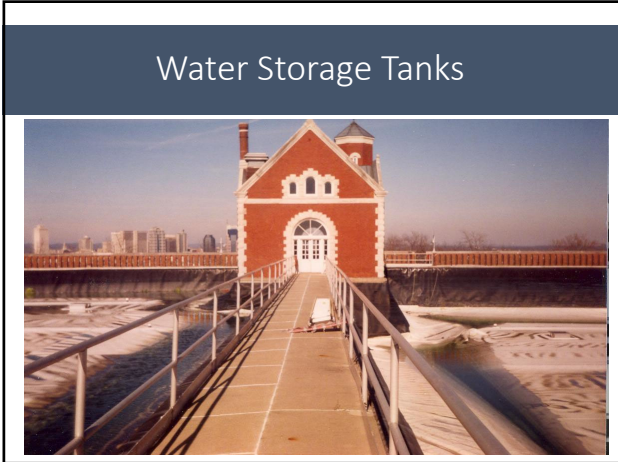

### Configuration of Storage Tanks

- Clearwell
- Elevated Tanks
- Ground-Level Reservoirs
- Standpipes
- Hydropneumatic System
- Surge Tanks

### Storage Facilities

- Provide a sufficient amount of water to average or equalize the daily demands
- Fire protection, industrial uses, reserve storage
- Types
  - Clear wells
  - Elevated tanks

### Storage Facilities

- Clear wells
  - Used for the storage of filtered water from a treatment plant
- Elevated tanks
  - Maintains adequate and fairly uniform pressure
  - Minimizes variations in the distribution system pressures
  - Equalizes water pressure in distribution system

### Storage Facilities

- Types
  - Standpipes
    - Stand on ground and have a height greater than diameter
  - Ground-level reservoirs
    - May be buried or on the ground surface

## Ground-Level Reservoirs



This is an old open-topped (8<sup>th</sup> Ave) reservoir that has been converted with a liner-cover

## Storage Facilities

### Hydropneumatic or pressure tanks

- A system in which a water pump is controlled by the air pressure in a tank partially filled with water
- Must contain proper air to water ratio: 2/3 water to 1/3 air
- **Insufficient air will cause pump to "short cycle"**

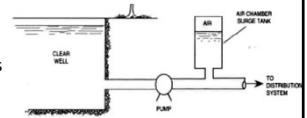

Fig. 2.8 Surge tank

### Surge tanks

- Used to control water hammer or regulate flow of water
- Should be located close to activity that may cause water hammer



Fig. 2.7 Hydropneumatic or pressure tank

## Storage Facilities – Elevated Tanks

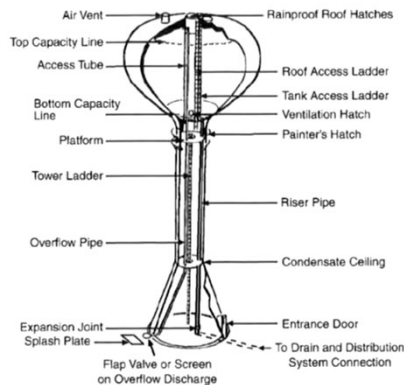

FIGURE 3-9 Principal accessories for an elevated storage tank  
Courtesy of CB&I

## Storage Facilities – Elevated Tanks

- Same pipe used for inlet and outlet called a riser
- Overflow pipe required in case water-level controls fail
  - Should be covered by weighted flap valve and **24 mesh non-corrodible screen**
- Must be furnished with drain connection to empty tank for maintenance and inspection
- Water level in tank monitored by either pressure sensor at base or level sensor inside tank
  - Telemetry equipment, altitude valves, overflow and low-level alarms
- Must be furnished with valve a connection to distribution system
- Altitude valve required if tank is not tall enough to accept full system pressure without overflowing
  - Automatically shuts off flow to tank when water level reaches overflow point

## Storage Facilities – Elevated Tanks

- Vents must be installed to allow air to enter and leave the tank as the water level changes
  - **4 mesh non-corrodible screen required**
- Access hatches must allow for entry and ventilation during maintenance and inspections
  - Hatches on roof must have rims under cover to prevent surface runoff entering the tank
  - Hatches at bottom must be able to withstand pressure of water column
- Multicolumn tanks generally have three ladders
  - One up a leg of tank to a balcony, one from balcony to roof, one installed on the roof

## Storage Tank Collapse

White City, Oregon

- Caused by massive leak in 42 inch water main (50,000 gallon per minute) which quickly drained the tank
- Vacuum formed sucking in the roof



## Storage Tank Collapse

- Storage tank was prepared to be painted
- Vent was covered with plastic
- As tank was draining, vacuum was formed, and tank imploded



## Storage Facilities – Elevated Tanks

- Interior and exterior coatings must be able to withstand harsh conditions
  - Exterior coatings must maintain a good appearance over a reasonable period of time
  - All paints must be acceptable to EPA or NSF for contact with potable water
- Cathodic protection reverses flow of current that dissolves iron and causes rust and corrosion
  - Should be used in conjunction with tank coatings
- FAA may require installation of obstruction lighting or strobe lights

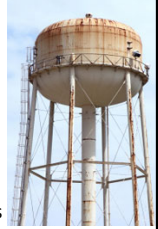

## Selection and Location of Storage

- Determined by hydraulics, water demand, elevation of terrain, purpose of tank, etc.
- Type of storage depends on purpose of tank
- What does this map mean?

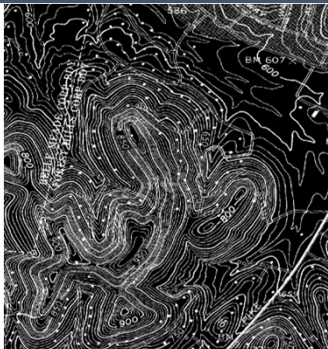

## Storage Facility Operations

- Supply water during high demand
  - Low demand times are used to fill the tank
- May use variation of pumps to maintain pressure in distribution system
  - Can be controlled automatically by instrumentation
  - Automated systems must be inspected regularly
- Abnormal operating conditions
  - Excessive water demands
  - Broke or out of service pumps, mains, or tanks
  - Stale water leading to taste and odor problems

## Storage Levels

- Water levels drop during peak demands and rise during low demands
- Water demands vary within the day, from day to day, and from season to season
  - Knowing these patterns, the operator can anticipate high-demand periods
- Automatic water level regulation can be achieved using altitude-control valves
  - A valve that automatically shuts off the flow into an elevated tank when the water level in the tank reaches a predetermined level
  - Prevent overflows
  - Maintains a constant water level based on system pressure

## Storage Level Controls

- Electrodes mounted at various levels in tank sense the change in water level and can start/stop the pump as needed
  - Can be difficult to reach for maintenance and replacement
  - Susceptible to corrosion or contamination
- Ultrasonic transmitters send a continuous sound wave to a receiver; when covered with water, the signal is broken
- Pressure switches respond to changes in water pressure
  - Must be properly calibrated
- Solid-state electronic sensors measure the actual water surface level
- Differential-pressure altitude valves can regulate water surface levels based on pressure

## Operation and Maintenance

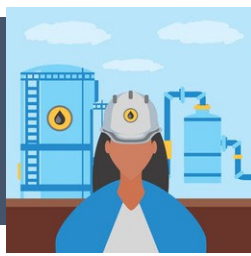

## Storage Facilities

- Inspections must be performed by third party every 5 years
  - Maintain record for 5 years
  - System operators should visually inspect tanks periodically
- Cleaning
  - Out-of-service cleaning consists of draining, washing, and disinfecting tank
  - In-service uses divers or remotely controlled equipment
- Booster pump is used to increase the pressure in the mains
  - Will not produce a negative pressure anywhere in the system
  - Pressure in suction line shall be maintained at or above 20 psi by the use of a pressure sustaining valve or low pressure cutoff device

## Facility Inspections

- Routine inspections part of normal, daily routine
  - Include check of security items
- Periodic inspections include climbing and looking inside
  - Check security items, site drainage, penetrations into the system, and overflows
- Comprehensive inspection must be performed by a professional every 5 years
  - Retain record for minimum of 5 years

## Comprehensive Inspections

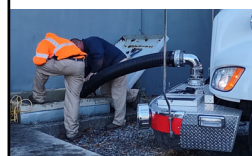

- 0400-45-01-.17(33) Community water systems shall have a professional inspection performed and a written report produced on each of their distribution storage tanks and clearwells at least once every five (5) years.
- 0400-45-01-.20(1)h Community water systems shall have a professional inspection performed and a written report produced on each of their distribution storage tanks and clearwells at least once every five (5) years.

## Facility Inspection

- Wet inspections conducted by divers or robots allow tank to remain filled
  - Higher chlorine residual required during inspection as well as a cleaning process to protect against bacterial contamination
  - Divers and equipment should be disinfected with 200 mg/L chlorine solution before entering tank
  - Divers equipped with surface supplied air, dry suit, and surface supplied equipment

## System Operations





## Pumps

- Centrifugal pumps must be primed
- Primed – filling a pump casing with water to remove the air
  - Primer pump will pump water into the pump casing to submerge the impeller
  - Priming water tank or auxiliary water supply can be used to add water to the pump casing bleeding off the air in the casing
  - Electric or hand-operated cause water to flow into the suction pipe and pump casing
- Foot valve – check valve located at bottom end of the suction pipe on a pump
  - Holds pumps prime

## Troubleshooting

- Water Quality Problems
  - Microbiological
    - Loss of chlorine residual
    - Bacterial growth
  - Chemical
    - Leaching of chemicals from linings and coatings
  - Physical
    - Settling and collection of sediment, rust & chemical precipitate

## Maintenance

- Three types:
  - **Preventive** – repair or adjustment of equipment and facilities that is done before deterioration takes place
  - **Predictive** – attempts to predict when a failure might occur
  - **Corrective** (repair) – maintenance that is necessary when a problem already exists
- Painting
  - Paints and coatings accepted by the Environmental Protection Agency (EPA) and/or the National Sanitation Foundation (NSF) for potable water contact are generally acceptable to the Department

## Corrosion Control

- Factors affecting corrosion
  - Warmer water = increased corrosion
  - Water velocity
    - High velocities in corrosive water will lead to rapid pipe deterioration
    - Low velocities lead to longer contact times and metal pickup (red or dirty water complaints)
  - Dissolved oxygen increases = increased corrosion
  - **Carbon dioxide increases = increased corrosion**
    - CO<sub>2</sub> lowers pH
  - Dissolved minerals increase = increased corrosion
  - Sulfate reducing bacteria = increased corrosion

## Corrosion Control

- A coat of paint is the least expensive type of corrosion control
- Metallic coatings such as zinc
- Nonmetallic coatings
- Chemicals added during treatment of water to deposit a protective coating or film on the tanks metal
  - Calcium hydroxide (lime), sodium carbonate (soda ash), zinc paints, orthophosphates
- Cathodic protection - electrical system for prevention of rust, corrosion, and pitting of metal surfaces that in contact with water or soil
  - Direct current applied to electrodes will cause them to corrode or be "sacrificed"

## Disinfection

- Disinfection is the inactivation/destruction of disease-causing organisms
- New storage facilities and those that have been repaired, cleaned, or had cathodic protection installed must be disinfected
- Follow AWWA Standard C-652, Disinfection of Water-Storage Facilities
- Always wear protective clothing
- Anyone entering tank must have on a safety harness
- Never enter a tank without two people standing by for rescue purposes

## Disinfection

- Liquid chlorine – Cl<sub>2</sub>
  - 100% pure
- Sodium hypochlorite – NaOCl
  - Bleach
  - 5-15% pure
- Calcium hypochlorite – Ca(OCl)<sub>2</sub>
  - HTH (high test hypochlorite)
  - 65% pure

## Disinfection – AWWA C652

- Method 1
- Fill tank to overflow level with potable water
    - Must have 10 mg/L at end of contact period
    - Liquid chlorine/sodium hypochlorite
      - Add to the water during filling operation to give a uniform chlorine concentration
    - Calcium hypochlorite
      - Crushed to not larger than ¼ inch and poured into tank before filling
  - Retention period
    - Liquid chlorine – 6 hours
    - Hypochlorite – 24 hours

## Disinfection – AWWA C652

- Method 2
- 200 mg/L chlorine applied directly to surface of all parts of tank that may come in contact with potable water
    - Sprayed or brushed on
    - Let sit for 30 minutes then fill tank to overflow

## Disinfection – AWWA C652

- Method 3
- Fill 5% of tank with 50 mg/L chlorine solution
    - Hold for 6 hours
  - Fill tank to overflow
    - Hold for 24 hours
    - Must have 2 mg/L at end of contact time

## Disinfection

- After disinfection, highly chlorinated water must be disposed of properly
  - Any water with concentration greater than 2 mg/L should be diluted or dechlorinated before disposal
  - Do not discharge to sanitary sewer without first communicating with the wastewater treatment plant
  - Chlorinated water should not be discharged to any surface waters with permission from the State
- After flushing, bacteriological testing must be performed and have negative results before putting tank in service
  - If bacteriological test return positive, disinfection and bac't testing must be repeated

## Ground Storage Tank Inspection Report

Job No.: \_\_\_\_\_ Date: \_\_\_\_\_ Inspector: \_\_\_\_\_

Tank owner: \_\_\_\_\_ Owner's order #: \_\_\_\_\_

Owner's representative: \_\_\_\_\_ Title: \_\_\_\_\_

Mailing address: \_\_\_\_\_

Physical address: \_\_\_\_\_

City, State: \_\_\_\_\_ Zip: \_\_\_\_\_

County tank is located: \_\_\_\_\_ Seismic zone of county: \_\_\_\_\_

Telephone: \_\_\_\_\_ Fax: \_\_\_\_\_

Location of tank: \_\_\_\_\_

Original Contractor #: \_\_\_\_\_ Year built: \_\_\_\_\_

Original Manufacturer: \_\_\_\_\_ Capacity: \_\_\_\_\_

Date of last inspection: \_\_\_\_\_

Diameter: \_\_\_\_\_ Height: \_\_\_\_\_

Type of construction:      Welded: \_\_\_\_\_ Riveted: \_\_\_\_\_

Who is customer's insurance carrier? \_\_\_\_\_

### Disinfection Log for Water Storage Tanks & Filters

Date:		Location:		WS Project#	-
Work Orders associated with project:					
Contractor :					
Work to be Completed:		Tank		Filter: #	

Disinfection: Tanks					
Disinfection Standards Followed:		State Approved		AWWA Standards C652	
Materials (scaffolding, rags, etc., ) removed from tank after work completed:				YES	NO
All screens checked and in satisfactory condition to prevent entry:				YES	NO
For AWWA Standards:	Method 1 (fill to overflow, drain, refill)	Method 2 (spray dose, sit, then fill)	Method 3 (fill 5%, sit, fill to overflow, sit)		
Actual Amount of Disinfectant Used:			Desired Chlorine Residual:		
Start Day / Time:		/ /	Contact Time:		hours
Secondary Start Day / Time:		/ /	Contact Time:		hours

Free chlorine residuals, turbidity, other test parameters collected:						
Date	Location	Parameter				Results
		Chlorine	Turbidity	pH	Alkalinity / Other	
		Chlorine	Turbidity	pH	Alkalinity / Other	
		Chlorine	Turbidity	pH	Alkalinity / Other	
		Chlorine	Turbidity	pH	Alkalinity / Other	
		Chlorine	Turbidity	pH	Alkalinity / Other	
Diver on Tank Inspections:		Acceptable Diving Qualifications			OSHA Confined Space Certified	

Disinfection: Filters					
Disinfection Standards Followed:		State Approved		AWWA Standards C653	
No materials (scaffolding, rags, etc., ) left in filter after work completed:				YES	NO
Facility cleaned, no foreign material present prior to disinfection:				YES	NO
Media placement follows ANSI/AWWA B100			Backwashed & prepared follows ANSI/AWWA B100		
Start Day / Time	/ /	Finished Day / Time (Filter placed in service):			/ /
Free Chlorine Residuals after disinfectant added:		Top:	mg/L	Bottom:	mg/L
Contact Time:					
Free Chlorine Residuals after contact time:		Top	mg/L	Bottom	mg/L
Filter backwashed and highly chlorinated water filtered to waste:				YES	NO

Bacteriological					
Sampling Procedure <sup>1</sup> :		Tank		Filter	
Location	Date	Time	Cl <sub>2</sub>	Results	
				NEG	POS
				NEG	POS
				NEG	POS
				NEG	POS
				NEG	POS

<sup>1</sup>Filter sampling requires two bacteriological samples collected at least thirty minutes apart per filter.

Employee Name: \_\_\_\_\_

Reviewed by: \_\_\_\_\_

## Storage Tank Vocabulary

- |                         |                          |
|-------------------------|--------------------------|
| A. Altitude Valve       | I. Hydropneumatic System |
| B. Booster Disinfection | J. Overflow Level        |
| C. Cathodic Protection  | K. Peak Hour Demand      |
| D. Elevated Storage     | L. Reservoir             |
| E. Elevated Tank        | M. Riser                 |
| F. Emergency Storage    | N. Silt Stop             |
| G. Fire Demand          | O. Standpipe             |
| H. Ground-level tank    | P. Tank                  |

- \_\_\_\_\_ 1. The required fire flow and the duration for which it is needed, usually expressed as gallons per minute for a certain number of hours. Also used to denote the total quantity of water needed to deliver the required fire flow for a specified number of hours.
- \_\_\_\_\_ 2. The greatest volume of water in an hour that must be supplied by a water system during any particular time period.
- \_\_\_\_\_ 3. A device placed at the outlet of water storage tanks to prevent silt or sediment from reaching the customer.
- \_\_\_\_\_ 4. An electrical system for preventing corrosion to metals, particularly metallic pipes and tanks.
- \_\_\_\_\_ 5. A system using an airtight tank in which air is compressed over water (separated from the air by a flexible diaphragm). The air imparts pressure to water in the tank and the attached distribution pipelines.
- \_\_\_\_\_ 6. A structure used in a water system to contain large volumes of water or other liquids.
- \_\_\_\_\_ 7. The maximum height that water or liquid will rise in a receptacle before it flows over the overflow rim.
- \_\_\_\_\_ 8. A valve that automatically shuts off water flow when the water level in an elevated tank reaches a preset elevation then opens again when the pressure on the system side is less than that on the tank side.
- \_\_\_\_\_ 9. Storage volume reserved for catastrophic situations, such as supply-line break or pump-station failure.
- \_\_\_\_\_ 10. (a) Any tank or basin used for the storage of water. (b) A ground-level storage tank for which the diameter is greater than the height.
- \_\_\_\_\_ 11. A ground-level water storage tank for which the height is greater than the diameter.
- \_\_\_\_\_ 12. In the distribution system, storage of water in a tank whose bottom is at or below the surface of the ground.
- \_\_\_\_\_ 13. In any distribution system, storage of water in a tank supported on a tower above the surface of the ground.
- \_\_\_\_\_ 14. The vertical supply pipe to an elevated tank.
- \_\_\_\_\_ 15. A water distribution storage tank that is raised above the ground and supported by posts or columns.
- \_\_\_\_\_ 16. The practice of adding additional disinfectant in the distribution system.

## Storage Tank Review Questions

1. List 9 reasons for providing water storage in a distribution system.
  - 
  - 
  - 
  - 
  - 
  - 
  - 
  - 
  -
2. List the 4 types of distribution storage tanks and a description of each.
  - 
  - 
  - 
  -
3. What is the difference between operating storage and emergency storage?
4. Why should vent openings on storage tanks be screened?
5. What is the purpose of an altitude valve?
6. How often must storage tanks be inspected according to the Regulations for Public Water Systems and Drinking water Quality for the State of Tennessee?

7. After disinfection, what must be done before a tank is put back in service?
8. Name four things that should be considered when determining the type and the site for a new storage tank.
- - 
  - 
  -
9. Why should the overflow pipe on a storage tank never be directly connected to a sewer or storm drain?
10. How are storage tanks protected from corrosion?

## Storage Tank Vocabulary

- |      |      |
|------|------|
| 1. G | 9. F |
| 2. K | 10.L |
| 3. N | 11.O |
| 4. C | 12.H |
| 5. I | 13.D |
| 6. P | 14.M |
| 7. J | 15.E |
| 8. A | 16.B |

## Storage Tank Review Questions

1.
  - Equalizing pressure and demand
  - Increasing operating convenience
  - Leveling out pumping requirements
  - Decreasing power costs
  - Providing water during source or power failure
  - Providing adequate water for fire fighting
  - Providing surge relief
  - Increasing detention time
  - Blending water sources
  
2.
  - Elevated – tank on tower, provides pressure, minimizes pressure variations
  - Standpipe – tank on ground, taller than diameter, stores large volumes of water at low pressure, safer than elevated tank, may require pump
  - Ground-level reservoir – diameter greater than height, requires pump
  - Hydro-pneumatic – 2/3 water, 1/3 air; air helps maintain pressure, usually used with wells; small tanks
  
3. Emergency storage is not considered to be potable water – for emergencies only, e.g. fire protection.  
Operating storage is directly connected to distribution system, fills and empties by distribution pressure.
  
4. To keep out birds, insects, animals, etc.
5. To keep tank from overflowing
6. Professionally every 5 years
7. Bacteriological samples must be taken and must pass.
8. Water demand; Hydraulics, terrain; Purpose of tank; Public opinion
9. That would be a cross connection
10. Cathodic protection, coatings



# **Section 6**

## **Disinfection**



# Disinfection

- California State University: Sacramento
- Water Distribution System Operation and Maintenance

## Objectives

- Disinfection
- Process of Disinfection
- Points of Chlorine Application
- Bacteriological Testing

## Safe Drinking Water Act

- USEPA sets drinking water standards and enforces these standards
  - State of TN has primacy
- Primary Drinking Water Regulations (1976) set specific maximum allowable levels of substances
  - MCL – maximum contaminant level
- Safe Drinking Water Act (1974) and its following amendments created the DBP Rule, ESWTR, GWDR, and LCR, etc.



## Purpose of Disinfection

- Disinfection – destruction or inactivation of pathogenic organisms
  - Performed in public drinking water systems
  - Pathogenic organisms – disease causing organisms
- Sterilization – complete destruction of all organisms

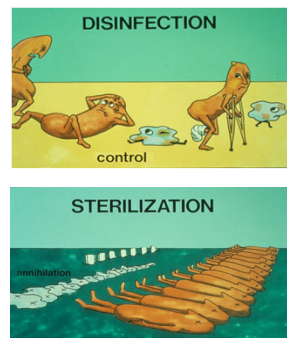

## Disinfection

“kill” is proportional to C x T

- Destruction of organisms depends on the concentration of chlorine added and the amount of time the chlorine is in contact with the organisms
- If one is decreased, the other must be increased to ensure that kill remains the same

## Chlorination Principles

- Five factors important to success of chlorination:
  - Water pH
  - Water temperature
  - Foreign substances in the water (reducing agents)
    - Turbidity
    - Microorganisms
  - Chlorine concentration (C)
  - Contact time (T)

} most important

### Factors Influencing Disinfection

Influencing Factor		Disinfection Efficiency
pH	↑	↓
Temperature	↑	↑
Reducing Agents	↑	↓

- pH
  - Ideal disinfection at 7.0 and below
- Temperature
  - Increased temperature = increased efficiency
  - Higher water temperatures can also lead to greater decrease in chlorine concentration
- Reducing Agents
  - Increased reducing agents = decreased efficiency

### Factors Influencing Disinfection

- Turbidity – suspended matter in water
  - Increased turbidity = decreased efficiency
  - Organic matter – forms DBPs when react with chlorine
    - Reduces chlorine left to disinfect
- Microorganisms
  - Increased concentration = decreased efficiency
  - Numbers and type determine efficiency
  - Cysts and viruses (Cryptosporidium and Giardia) more resistant to disinfectants
- Disinfection considerations
  - Chlorine is the recommended disinfectant

## Process of Disinfection



## Disinfection

- Physical disinfection
  - Physically remove the organisms from the water
  - Introduces motion that will disrupt the cells' biological activity and kill or inactivate them
- Chemical disinfection
  - Alters the cell chemistry causing microorganisms to die

### Physical Means of Disinfection

- Ultraviolet rays (UV)
  - Rays must come in contact with each microorganism
  - UV disrupts components of cell that is fatal to cell
  - No measurable residual and high cost
- Heat
  - Boiling water for 5 minutes destroys all microorganisms
- Ultrasonic waves
  - Sonic waves destroy microorganisms by vibration

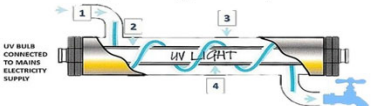

### Chemical Disinfectants (other than chlorine)

- Iodine
  - Limited to emergency treatment for a few weeks
- Bromine
  - Difficult to handle, burns skin, difficult to maintain residual,





## Chemical Disinfectants (other than chlorine)

- Bases (sodium hydroxide & lime)
  - Raises pH and changes taste of water
  - Sterilizes the water
- Ozone
  - Used primarily for taste & odor control due high costs, lack of chlorine residual, difficulty in storing, and maintenance requirements
  - Used successfully for pretreatment of natural organic matter (NOM) and reducing DBP potential

## Chlorine Gas (Cl<sub>2</sub>)

- “Liquid Chlorine”
- Greenish-yellow with distinctive odor
- 2.5 times heavier than air
- High expansion coefficient
  - 460 times
  - Containers should be filled no more than 85%
- Nonflammable, non-explosive, but will support combustion
  - As temperature increases, gas will expand within the cylinder

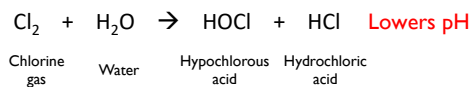
## Chlorine Gas (Cl<sub>2</sub>)



- Hypochlorous acid is the primary disinfectant
- As the pH increases, the HOCl will disassociate

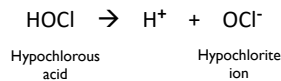

- Hypochlorite is much less effective, but still works

## Hypochlorite (OCl<sup>-</sup>)

Raises pH

- Sodium hypochlorite – NaOCl
  - Liquid bleach
  - 5-15% pure

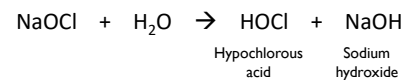

- Can lose 2-4% available chlorine content at room temperature
- Max storage 60-90 days

## Hypochlorite (OCl<sup>-</sup>)

- Calcium hypochlorite - Ca(OCl)<sub>2</sub> Raises pH
  - Solid HTH (high test hypochlorite)
  - 65% pure

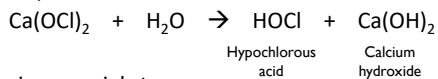

- Requires special storage
  - When comes into contact with organic material, can result in fire
- Add calcium hypochlorite to water, not water to calcium hypochlorite
  - Disperses heat produced by reaction with organics

## Chlorine Dioxide (ClO<sub>2</sub>)

- Does not react with organics
  - Does not form DBPs
- Effective at higher pH levels
- Can have odor complaints with some customers



- Good oxidizing agent to precipitate inorganic substances
  - e.g. Iron and manganese

## Chlorination

### Disinfection Action

- **Chlorine demand** - the point where the reaction with organic and inorganic materials (aka reducing agents) stops
- **Chlorine residual** - the total of all the compounds with disinfecting properties plus any remaining free chlorine
- **Chlorine dose** - the amount of chlorine needed to satisfy the chlorine demand and the amount of chlorine residual needed for disinfection

$$\text{Dose} = \text{Demand} + \text{Residual}$$

## Breakpoint Chlorination

- The process of adding chlorine to water until the chlorine demand has been satisfied
  - Further additions of chlorine will result in a chlorine residual that is directly proportional to the amount of chlorine added *beyond the breakpoint*

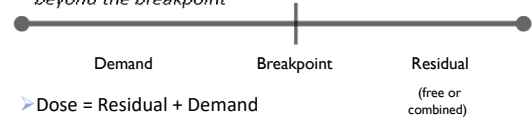

- $\text{Dose} = \text{Residual} + \text{Demand}$
- OR
- $\text{Demand} = \text{Dose} - \text{Residual}$

## Breakpoint Chlorination Video

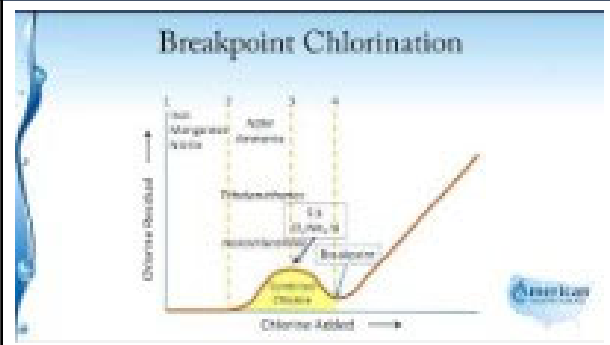

## Chlorine Residual Testing

- “Public Water Systems ... shall continuously chlorinate and maintain a free chlorine residual of 0.2 mg/l in all parts of the distribution system.”
- A lack of residual can indicate heavy contamination
- Actions to take if abnormal lack of residual
  - Retest for chlorine residual
  - Check chlorination equipment
  - Searching for source of contamination that could be increasing the demand

## Points of Chlorine Application



## Water Mains

- All new mains must be disinfected prior to being placed into service in accordance with AWWA C-651
- Take measures to prevent contamination during installation
- Follow AWWA C651 for proper disinfection procedures

## AWWA C651

- Inspect materials to be used to ensure integrity
- Prevent contamination entering water main during storage, construction, repair
- Remove contaminating materials in main by flushing or other means
- Chlorinate main and flush chlorinated water from main
- Protect existing distribution system from backflow
- Document adequate chlorine level
- Determine bacteriological quality
- Connect approved main to active distribution system

## AWWA C651

### ➤ Three methods of chlorination

- Tablet method
- Continuous feed method
- Slug method

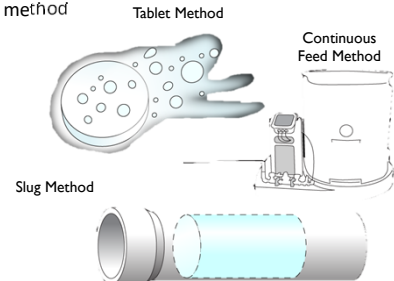

## Tablet Method (AWWA C651)

- Placing of 5 gram tablets
  - In each section of pipe
  - In each hydrant, hydrant branch, and other appurtenances
  - Tablets attached with food grade adhesive to broad side of tablet
  - Attach tablets to inside top of main
- # tablets =  $(0.0012)(D^2)(L)$ 
  - D = inside pipe diameter, inches
  - L = length of pipe section, feet



## Tablet Method (AWWA C651)

- Filling and contact
  - Fill with clean water at less than 1 ft/sec
  - Take measures to eliminate air pockets
  - Hold chlorinated water in pipes for no less than 24 hrs
    - If less than 41°F, hold water for 48 hrs
  - Must have detectable residual at end of 24 hours at each sampling point

## Continuous Feed Method (AWWA C651)

- Flush main to eliminate air pockets and remove particulates
  - Flushing velocity should be not less than 2.5 ft/sec
- Water main should undergo and pass hydrostatic testing prior to disinfection
- Dose water entering main with 25 mg/L free chlorine not more than 10 feet downstream from beginning of main
  - Regularly check chlorine concentration during filling
  - Apply chlorine until entire main filled with heavily chlorinated water

## Continuous Feed Method (AWWA C651)

- Hold water in main for 24 hours
  - All portions must have 10 mg/L residual at end of 24 hours
- Direct feed chlorinators from chlorine gas cylinders shall not be used
- Hypochlorite solutions may be applied to main with gasoline or electrically powered chemical feed pump

## Slug Method (AWWA C651)

- Dose water entering main with 100 mg/L free chlorine not more than 10 feet downstream from beginning of main
  - Regularly check chlorine concentration during filling
  - Apply chlorine continuously to develop sludge of chlorinated water
  - This should expose all interior surfaces to a concentration of approximately 100 mg/L for at least 3 hours
  - If residual in slug drops below 50 mg/L, stop flow, move chlorination equipment to head of slug, apply chlorine to bring residual up to no less than 100 mg/L
- Operate all valves and hydrants as slug flows past them to disinfect appurtenances and pipe branches

## Flushing Final (AWWA C651)

- After appropriate retention period, flush highly chlorinated water from main
  - Prolonged contact should be avoided to minimize damage to pipe lining, pipe corrosion
  - Flush main until normal chlorine concentration is achieved
- Dispose of highly chlorinated water appropriately
  - Neutralize chlorine if possible
  - If possible negative environmental impact occurs, contact local state agency immediately
  - If disposing to sewer system, notify wastewater treatment plant prior to discharge

## WSO Video



## Bacteriological Testing



## New Main Bacteriological Testing 0400-45-01-.17(8)(b)

- Bacteriological samples will be collected and analyzed to verify the effectiveness of the disinfection practices **prior to placing new facilities in service**. Bacteriological samples shall be collected to determine the effectiveness of the installation process including protecting the pipe material during storage, installation, and disinfection.
- This can be demonstrated by collecting **two sets of microbiological samples 24 hours apart** or **collecting a single set of microbiological samples 48 hours or longer after flushing the highly chlorinated water from the lines**. In either case microbiological samples in each set will be collected at approximately **2,500-foot intervals with samples near the beginning point and at the end point** unless alternate sampling frequency and distance between sampling points approval has been obtained from the Department.

## New Main Bacteriological Testing 0400-45-01-.17(8)(b)

- Where sanitary conditions were not maintained before, during or after construction, an additional bacteriological sample shall be collected from a location representing the water from the contaminated area. Unsanitary conditions include failure to document the sanitary handling of materials, to conduct construction inspections and to maintain records, and to document sanitary practices during construction and other hazards such trench flooding during construction.
- **If the constructed facility yields positive bacterial samples, the line shall be flushed and resampled. If subsequent samples are positive, the line shall be disinfected, flushed and resampled again.**

## Bacteriological Testing

- Must be performed for all new main installation
- Test for indicator organism

### **Total Coliform**

- Maximum holding time for bacteriological testing is **30 hours**



## Common Waterborne Diseases

Waterborne Disease	Causative Organism	Source of Organism in Water	Symptom
Gastroenteritis	<i>Salmonella</i> (bacteria)	Animal or human feces	Acute diarrhea and vomiting
Typhoid	<i>Salmonella typhosa</i> (bacteria)	Human feces	Inflamed intestine, enlarged spleen, high temperature - <b>FATAL</b>
Dysentery	<i>Shigella</i> (bacteria)	Human feces	Diarrhea - rarely fatal
Cholera	<i>Vibrio comma</i> (bacteria)	Human feces	Vomiting, severe diarrhea, rapid dehydration, mineral loss – high mortality
Infectious Hepatitis	Virus	Human feces, shellfish grown in polluted waters	Yellow skin, enlarged liver, abdominal pain – low mortality, lasts up to 4 months
Amoebic Dysentery	<i>Entamoeba histolytica</i> (protozoan)	Human feces	Mild diarrhea, chronic dysentery
Giardiasis	<i>Giardia lamblia</i> (protozoan)	Animal or human feces	Diarrhea, cramps, nausea and general weakness – not fatal, lasts 1-30 weeks
Cryptosporidiosis	<i>Cryptosporidium</i> (protozoan)	Human and animal feces	Acute diarrhea, abdominal pain, vomiting and low-grade fever
Legionellosis	<i>Legionella pneumophila</i> and related bacteria		Acute respiratory illness

# Fleming Training Center

## Pipe Disinfection Formulas for 50 mg/L of HTH

If a pipe is of size not listed below, the following formula will give the calculations needed to find the amount of HTH needed, if the length of line is given:

$$\text{Calculation Formula} = 0.000026007(D)^2(L)$$

L= the length of the line in feet,  
D = the diameter in inches

**Or, Use the following Chart, if Pipe Diameter is listed**

DIAMETER (INCHES)	LBS OF HTH
6	0.000935(L)
8	0.00166(L)
10	0.0026(L)
12	0.00374(L)
14	0.00509(L)
16	0.00665(L)
20	0.01038(L)
C24	0.01495(L)

## Disinfection Vocabulary

- |                            |                           |
|----------------------------|---------------------------|
| A. Bacteria                | J. DPD                    |
| B. Breakpoint              | K. Free Residual Chlorine |
| C. Chlorination            | L. HTH                    |
| D. Chlorine Demand         | M. Organic Substance      |
| E. Combined Residual       | N. Ozone Generator        |
| F. C x T Value             | O. Sterilization          |
| G. Disinfection Residual   | P. Trihalomethane         |
| H. Disinfection            | Q. UV Disinfection        |
| I. Disinfection By-Product | R. Waterborne Disease     |

- \_\_\_\_\_ 1. The process of destroying all organisms in water.
- \_\_\_\_\_ 2. The product of the residual disinfectant concentration C and the corresponding disinfectant contact time T.
- \_\_\_\_\_ 3. The water treatment process that kills disease-causing organisms in water.
- \_\_\_\_\_ 4. A device that produces ozone by passing an electrical current through air or oxygen.
- \_\_\_\_\_ 5. The point at which the chlorine dose has met the demand.
- \_\_\_\_\_ 6. Living organisms, microscopic in size, which usually consist of a single cell.
- \_\_\_\_\_ 7. A chemical substance of animal or vegetable origin, having carbon in its molecular structure.
- \_\_\_\_\_ 8. Disinfection using ultraviolet light.
- \_\_\_\_\_ 9. The process of adding chlorine to water to kill disease-causing organisms.
- \_\_\_\_\_ 10. The residual formed after the chlorine demand has been satisfied.
- \_\_\_\_\_ 11. An excess of chlorine left in water after treatment. Indicates the adequate amount of disinfectant has been added to ensure complete disinfection.
- \_\_\_\_\_ 12. Compound formed when organic substances such as humic and fulvic acids react with chlorine.
- \_\_\_\_\_ 13. The difference between the amount of chlorine added to water and the amount of residual chlorine remaining after a given contact time.
- \_\_\_\_\_ 14. Chemical compounds that are formed by the reaction of disinfectants with organic compounds in water.
- \_\_\_\_\_ 15. High Test Hypochlorite; calcium hypochlorite or  $\text{Ca}(\text{OCl})_2$
- \_\_\_\_\_ 16. The chlorine residual produced by the reaction of chlorine with substances in the water. It is not as effective as free residual.
- \_\_\_\_\_ 17. A disease caused by waterborne organisms.
- \_\_\_\_\_ 18. A method of measuring the chlorine residual in water. The residual may be determined by either titrating or comparing a developed color with color standards. Stands for N,N-diethyl-p-phenylene-diamine.

## Answers

### Vocabulary

1. O
2. F
3. H
4. N
5. B
6. A
7. M
8. Q
9. C
10. K
11. G
12. P
13. D
14. I
15. L
16. E
17. R
18. J

## Disinfection Vocabulary

A. breakpoint chlorination	H. enteric	O. potable water
B. carcinogen	I. free available chlorine residual	P. reducing agent
C. chlorine demand	J. HTH	Q. residual chlorine
D. chlorination	K. hypochlorite	R. sterilization
E. coliform	L. oxidation	S. total chlorine
F. combined chlorine	M. oxidizing agent	T. trihalomethanes (THMs)
G. disinfection	N. pathogenic organisms	U. turbidity

- \_\_\_\_\_ calcium hypochlorite ( $\text{Ca}(\text{OCl})_2$ ): high test hypochlorite
- \_\_\_\_\_ organisms, including bacteria, viruses, protozoa, or internal parasites, capable of causing diseases in a host
- \_\_\_\_\_ total concentration of chlorine in water including the combined chlorine and free available chlorine
- \_\_\_\_\_ the amount of chlorine required to destroy all reducing agents in a water
- \_\_\_\_\_ derivatives of methane often formed during chlorination by reactions with natural organic materials in the water; suspected carcinogens
- \_\_\_\_\_ the removal or destruction of all microorganisms, including pathogens and other bacteria
- \_\_\_\_\_ any substance that will readily donate electrons; will increase chlorine demand by consuming it for disinfection
- \_\_\_\_\_ application of chlorine to water, generally for the purpose of disinfection
- \_\_\_\_\_ the concentration of chlorine present in water after the chlorine demand has been satisfied
- \_\_\_\_\_ of intestinal origin, especially applied to wastes or bacteria
- \_\_\_\_\_ chemical compounds containing available chlorine; used for disinfection; available as liquid or solid
- \_\_\_\_\_ any substance that tends to produce cancer in an organism
- \_\_\_\_\_ any substance such as oxygen or chlorine that will readily take on electrons and oxidize substances causing them to precipitate out of solution as a solid
- \_\_\_\_\_ water that does not contain objectionable pollution, contamination, minerals or infective agents and is considered satisfactory for drinking
- \_\_\_\_\_ cloudy appearance of water caused by the presence of suspended and colloidal matter
- \_\_\_\_\_ the sum of the chlorine species composed of free chlorine and ammonia

17. \_\_\_\_\_ the addition of oxygen, removal of hydrogen, or the removal of electrons from an element or compound
18. \_\_\_\_\_ addition of chlorine to water until the chlorine demand has been satisfied; any additional chlorine will result in a free chlorine residual
19. \_\_\_\_\_ that portion of the total available chlorine residual that has not combined with other compounds
20. \_\_\_\_\_ group of bacteria found in the intestines of warm-blooded animals and also in plants, soil, air and water
21. \_\_\_\_\_ process designed to kill or inactivate most pathogenic microorganisms in water or wastewater

**Answers**

- |       |       |
|-------|-------|
| 1. J  | 12. B |
| 2. N  | 13. M |
| 3. S  | 14. O |
| 4. C  | 15. U |
| 5. T  | 16. F |
| 6. R  | 17. L |
| 7. P  | 18. A |
| 8. D  | 19. I |
| 9. Q  | 20. E |
| 10. H | 21. G |
| 11. K |       |

## Disinfection Review Questions

1. What are pathogenic organisms?
2. What is disinfection?
3. Drinking water standards are established by what agency of the United States Government?
4. MCL stands for what words?
5. How does the pH of water being treated influence the effectiveness of disinfection?
6. How does temperature of the water influence disinfection?
7. What two factors influence the effectiveness of disinfection on microorganisms?
8. What are possible sources of drinking water contamination in distribution systems?
9. List the physical agents that have been used for disinfection.
10. List the chemical agents other than chlorine that have been used for disinfection.
11. What is a major limitation to the use of ozone?
12. How is the chlorine dosage determined (mathematically)?

13. How is chlorine demand determined (mathematically)?
14. How does the reaction of chlorine gas in water and the reaction of hypochlorite in water influence the water's pH?
15. What is breakpoint chlorination?
16. What are the three methods of disinfecting water mains allowed by State of Tennessee?
17. How long should the highly chlorinated water be retained in the water mains in the tablet method and continuous feed method?
18. What is the minimum residual to be detected in all parts of the main after 24 hours in the tablet method?
19. What is the minimum residual to be detected in all parts of the main after 24 hours in the continuous feed method?
20. What is the minimum chlorine residual allowed when filling the main in the slug method of water main disinfection?
21. After disinfection is complete, what is the next step in the disinfection process?
22. When and how should bacteriological samples be collected after disinfection and flushing of new water mains?



23. Where should samples of new water mains be collected after disinfection?

24. What should an operator do if a bacteriological test come back positive for a new main installation?

## Disinfection Review Questions – Answers

1. disease producing organisms
2. the selective destruction or inactivation of pathogenic organism
3. US Environmental Protection Agency (USEPA)
4. maximum contaminant level
5. chlorine disinfects better at lower pH
6. higher temperatures are disinfected more efficiently
7. number and type of organisms
8. new main installation, cross connections, and main breaks
9. ultraviolet rays, heat, ultrasonic waves
10. iodine, bromine, bases (sodium hydroxide and lime), and ozone
11. its inability to provide a residual in the distribution system
12. chlorine dose = demand + residual
13. demand = dose – residual
14. chlorine gas in water will lower pH, while hypochlorite in water will raise the pH
15. the addition of chlorine to water until the chlorine demand has been satisfied and further additions of chlorine result in a free available chlorine residual that is directly proportional to the amount of chlorine added beyond the breakpoint
16. tablet method, continuous feed method, slug method
17. 24 hours
18. detectable level
19. 10 mg/L
20. 50 mg/L
21. flushing of the highly chlorinated water until a normal residual is found
22. (1) 24 hours after flushing collect one set of representative samples, 24 hours later collect another set of representative samples; (2) 48 hours after flushing collect 2 sets of representative samples
23. samples in each set will be collected at approximately 2,500-foot intervals with samples near the beginning point and at the end point unless alternate sampling frequency and distance between sampling points approval has been obtained from the Department
24. re-disinfect, re-flush, and retest until the tests come back negative

## **Section 7**

### **Hydrants**



**Fleming Training Center**  
Your Partner in Clean Water



**TN** Department of  
**Environment & Conservation**

# Fire Hydrants





- AWWA Water Transmission and Distribution
- CSUS Water Distribution System

## Objectives

- Fire Hydrant Uses & Operation
- Types of Fire Hydrants
- Parts of Fire Hydrants
- Inspection and Installation
- Operation and Maintenance

## Fire Hydrant Uses

- Public fire protection – primary function
- Flushing water mains
- Flushing sewers
- Filling tank trucks for street washing, tree spraying, and other uses
- Providing a temporary water source for construction jobs
- Miscellaneous Uses
  - Authorized use should be strictly controlled
  - Unauthorized use should be absolutely prohibited
  - Must provide backflow protection

## Issues Caused by Hydrant Operation

- Negative pressure can be created by pumper truck if mains are not large enough
  - Cross-connection due to back siphonage
  - Hydrants should be installed only on mains 6 inches or larger
- Increased flow can scour sediment deposited inside pipeline
  - Customer complaints
- Opening or closing hydrant too fast can cause water hammer
  - Hydrant can shift if not firmly blocked
  - Distribution system damage

## Types of Fire Hydrants



**Fleming Training Center**  
Your Partner in Clean Water



**TN** Department of  
**Environment & Conservation**

## Types of Hydrants

- Dry-barrel hydrants
- Wet-barrel hydrants
- Warm-climate hydrants
- Flush hydrants



### Dry-Barrel Hydrants

- Equipped with a main valve and drain in base
- Barrel only filled with water when main valve is opened
- Used mainly in climates that freeze
- Water will not flow from a broken hydrant

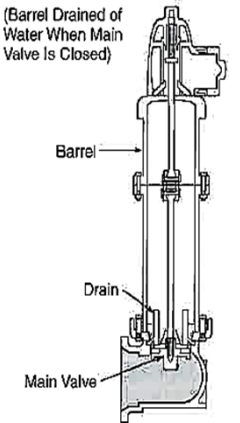

(Barrel Drained of Water When Main Valve Is Closed)

### Dry-Barrel Hydrants

- **Wet-Top Hydrants**
  - Threaded end of main rod and operating nut are not sealed from water when main valve is open
- **Dry-Top Hydrants**
  - Threaded end of the operating stem is sealed from water in barrel when hydrant is in use
  - Reduces possibility of threads being contaminated by sediment or corrosion

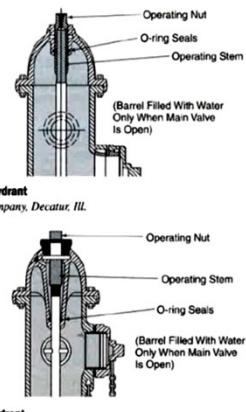

Operating Nut  
O-ring Seals  
Operating Stem  
(Barrel Filled With Water Only When Main Valve Is Open)

Operating Nut  
Operating Stem  
O-ring Seals  
(Barrel Filled With Water Only When Main Valve Is Open)

### Dry-Barrel Hydrants

- **Valve Types**
  - Standard compression hydrant – valve closes with the water pressure against the seat to aid in providing a good seal
  - Slide gate hydrant – valve is gate valve
  - Toggle (Corey) hydrant – valve closes horizontally and barrel extends well below the branch line

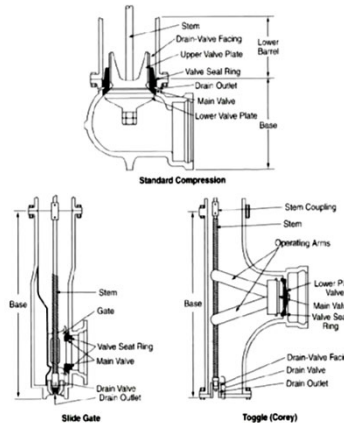

Standard Compression

Slide Gate

Toggle (Corey)

### Dry-Barrel Hydrants

- **Breakaway ("traffic") Hydrants**
  - Two part barrel with flanged coupling just above ground level
  - Flange and operating stem designed to break on impact
  - Repair by replacing the breakaway flange and stem coupling

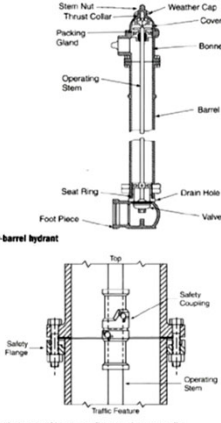

Stem Nut  
Weather Cap  
Cover  
Thrust Collar  
Packing Gland  
Bonnet  
Operating Stem  
Barrel  
Seal Ring  
Drain Hole  
Foot Piece  
Valve

Safety Flange  
Safety Coupling  
Traffic Feature  
Operating Stem

### Wet-Barrel Hydrants

- Completely filled with water at all times
- No main valve
- Each nozzle equipped with a valve
- Cannot be used in freezing climates
- Broken hydrant will allow water to flow until the water can be shut off

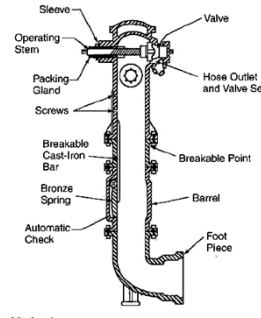

Sleeve  
Operating Stem  
Valve  
Hose Outlet and Valve Seat  
Packing Gland  
Screws  
Breakable Cast-Iron Bar  
Bronze Spring  
Automatic Check  
Breakable Point  
Barrel  
Foot Piece

### Flush Hydrants

- Entire standpipe and head are below ground
- Operating nut and outlet nozzle encased in box
- Usually of the dry barrel type



# Parts of Fire Hydrants



## Hydrant Parts

- Upper Barrel - carries water from lower barrel to outlet nozzles
  - Operating nut - pentagon shaped nut
    - Usually turns counterclockwise
    - Only operated with hydrant wrench
  - Bonnet - top cover or closure
  - Outlet nozzles
    - Smaller diameter nozzles for connecting to fire hoses
    - Larger nozzle (pumper or steamer nozzle) connects to pumper suction hose
      - 18" from center to ground level

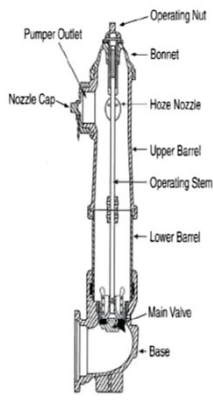
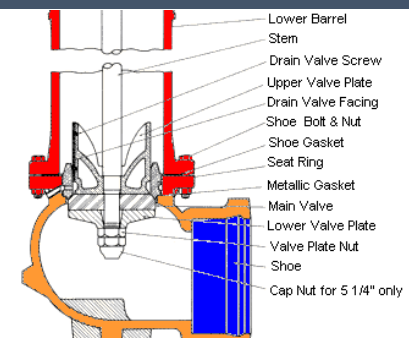

**FIGURE 7-10 Main parts of a typical fire hydrant**  
*Courtesy of U.S. Pipe and Foundry Company*

## Hydrant Parts

- Lower Section
  - Includes lower barrel, main valve, base
  - Carries water flow between base and the upper barrel
  - Should connect to upper barrel approximately 2 inches above ground level
  - Main valve assembly
    - Operating stem, resilient valve gasket,
  - Base
    - aka shoe, inlet, elbow, foot piece
- Auxiliary Valves
  - Should be installed on every hydrant
  - Typically, valve is directly connected to hydrant by flanged connection
    - Valve cannot separate from hydrant

## Hydrant Parts – Lower Barrel



## WSO Hydrant Video



## Inspection and Installation



## Inspection of New Hydrants

- Inspect at time of delivery
  - Direction to open hydrant
  - Size and shape of operating nut
  - Depth of bury
  - Size and type of inlet connection
  - Main valve size
  - Outlet-nozzle sizes and configuration
  - Nozzle thread dimensions
- Cycle hydrant to full open and full closed positions
- Check all external bolts for tightness
- After inspection, close all valves and cap outlet nozzles
- If stored outside during cold weather, place hydrant with inlet down

## Installation

- Location
  - Set back at least 2 feet from curb; farther in areas without a curb
  - Pumper outlet nozzle should face the street
  - Guard posts may be necessary if vulnerable to traffic
- Footing and Blocking
  - Set on firm footing that will not rot or settle, e.g., flat stone or concrete slab
  - Must be blocked from movement to prevent a joint opening due to water hammer
    - Excavate to preserve undisturbed earth behind the hydrant base
    - Concrete block then poured between base and undisturbed earth
      - Take care not to block the drain hole
    - If undisturbed earth is not available, the block must be restrained by rods or fittings
      - Common to use shackle rods ¾ inch in diameter

## Installation

- Drainage
  - Excavate around base of hydrant to allow placement of clean stone
  - Top of stone slightly above drain opening and covered with heavy plastic or tar paper to prevent clogging with dirt
  - If water table too high to allow drainage, plug hydrant drains
    - Mark hydrant so barrel will be pumped dry with a hand pump after use
- Hydrant Painting
  - Easily visible both day and night
  - Color coding indicates capacity to assist fire department

Class	Flow, gpm	Color
AA	Greater than 1500	Blue
A	1000-1499	Green
B	500-999	Orange
C	Less than 500	Red

## Installation

- Testing
  - Do not pressure test hydrant with new main
  - After main is tested, open auxiliary valves and test hydrant
    - Open hydrant fully and fill with water
    - Vent air through one slightly loosened cap; tighten cap after all air escaped
    - Apply pressure up to 150 psi or 1.5 normal working pressure, whichever is greater
    - Check for leakage at flanges, nozzles, and operating stem
      - Repair/replace any components causing leakage
  - Tighten loose flange bolts and nozzles
  - Operate hydrant after backfilling to flush any foreign material
  - Tighten nozzle caps so they cannot be removed by hand but not excessively tight

## Installation

- AWWA Standard C502-18
  - 5.1.3 Hydrostatic Test
    - Each assembled hydrant shall be subjected to two shop tests under a hydrostatic pressure of 300psig (2,068 kPa [gauge]) or twice the rated working pressure, whichever is greater
    - One test shall be made with the entire interior of the hydrant under pressure and another test made with the main valve closed and the base under pressure from the inlet side.
    - Under the test conditions, the leakage through the drain valve shall not exceed 5 fl oz/min (148 mL/min)
    - The tests shall be conducted for a sufficient time to allow a check of points of possible leakage and for a minimum of 30 sec after air has been exhausted.





ANSI/AWWA C502-18  
(Revision of ANSI/AWWA C502-14)

American Water Works Association  
Essential to the World's Most Important Resource®

AWWA Standard

Dry-Barrel Fire Hydrants

## Operation and Maintenance

## Hydrant Operation

- Designed to be operated by one person using a 15-inch wrench
  - Using a "cheater bar" should be avoided
- Main valve should always be completely opened when in use
  - Allows drain valve to close completely
  - Throttling leads to valve seat and rubber damage
  - If throttling is necessary, use a nozzle cap fitted with a gate valve
- If main valve is not fully closed, leakage from drain valves will occur
  - Can saturate surrounding soils and prevent proper drainage of barrel
  - Can undermine hydrant footing or blocking



[Hydrant Flushing Program | Murfreesboro, TN - Official Website \(murfreesborotn.gov\)](#)

## Hydrant Maintenance

- Inspect and maintain hydrants at least twice a year and after each use
- Check that nothing external can interfere with operation
- Ensure nothing attached to outlet nozzles
- Visually inspect hydrant for leaning or other signs it has been hit
- Remove outlet nozzle to check for water or ice in the barrel
- Use listening device to check for seat leakage
- Replace outlet nozzle and fully open hydrant
  - Check ease of operation; if stem action is tight, repeat action until it is smooth and free
- While pressurized, check for leakage at joints, outlet nozzles & caps, and at packing or seals

## Hydrant Maintenance

- Open hydrant fully allowing it to flow for short time
  - Be sure to dispose of water properly
- Close main valve enough to allow flow through drains under pressure to flush drain holes then close main valve completely
- Inspect all outlet nozzles and caps for thread damage
  - Clean and lubricate threads and gaskets
- Lubricate operating nut threads according to manufacturer's instructions
- Check that barrel drains properly
  - Feel suction rapidly being created when hand placed over outlet nozzle during drainage
- Use listening device to check again for seat leakage

## Hydrant Maintenance

- If dry barrel does not drain, pump out any residual water
- Check outlet nozzle cap chains for free action
- On traffic hydrants, check the breakaway device
  - Inspect couplings, cast lugs, special bolts, and other parts for damage

## Hydrant Repair

- Fire department must be notified before starting repair
- Turn off auxiliary valve then disassemble hydrant according to manufacturer instructions
  - Replace any worn or damaged parts
  - Replace all gaskets packing and seals regardless of condition
- Open auxiliary valve then test hydrant
- Inform fire department
- Record date and details of repair

## Operation and Maintenance

- Flow Testing
  - Usually made from hydrants using a pitot gauge (tube)
    - Aka pitot tube – a device for measuring the velocity head of the stream as an indicator of velocity
  - Provides data on system flow and fire flow capabilities
  - Should be retested after any major changes in the distribution system



Components of a Pitot Gauge

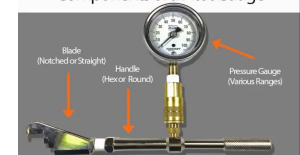



## Operation and Maintenance

- Hydrant Records
  - Record for each hydrant should be maintained
    - Each time inspection made
    - All repair work performed
  - At installation
    - Make
    - Model
    - Location
- Fire Flow Testing
  - One or more hydrant used for test
  - Hydrants operated from zero to full flow while measuring pressure at a nearby hydrant
  - Notify customers beforehand

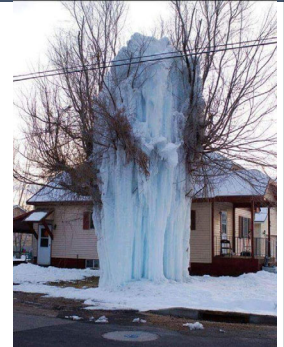

## Operation and Maintenance

- Hydrant Safety
  - Force and volume of water from a fully opened hydrant are enough to injure workers or pedestrians
  - Traffic control important to ensure drivers avoid hydrant stream without swerving or causing accidents
  - In freezing temperatures, water flowed onto pavement may freeze and cause accidents
  - Take care to keep a separation between a connected hose and a sewer drain to prevent a cross connection
  - Anchor end of hose to prevent swinging and possible injury



## Hydrant Safety

- During flow test, hydrant nozzle must be unobstructed
  - Take precautions to divert traffic and prevent property damage from flowing water
- Flow diffusers or a fire hose should be used to direct flow into a gutter or drainage ditch
- Rigid pipe connected to outlet and turned at an angle is not good practice
  - Torque produced by angular flow could twist or damage hydrant





## Water Main Flushing Program

➤ Fleming Training Center

## Flushing Program – Why Do It?

- Important preventative maintenance
  - Removes particulate matter and corrosion from lines
- Improve water quality
  - Low chlorine residual
  - Brown water
  - Taste and odor complaints
  - Positive bacterial counts
  - Low water pressure



## Flushing Programs

- How frequently should you flush?
  - Surface waters systems are usually going to flush more often due to increased nutrients in the water.
  - Water quality indicators can be used to increase flushing:
    - Temperature, increase
    - Chlorine residual, decrease
    - Corrosion inhibitor, decrease
    - pH, decrease
    - Taste and odor, increase in complaints

## Flushing Program

- 2 types:
  - Unidirectional
    - Water system valves are operated to create a one-way flow of the water, this increases the speed and scours the lines removing biofilm and corrosion
  - Conventional
    - The water used to flush the main does not always begin at a clean water source and the speed is low therefore more water is needed to clean mains

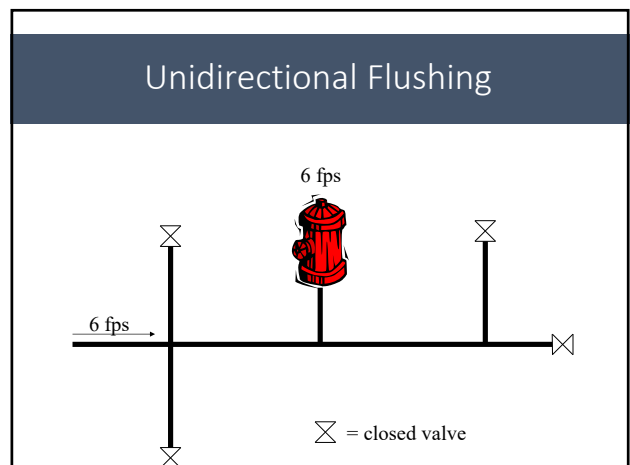
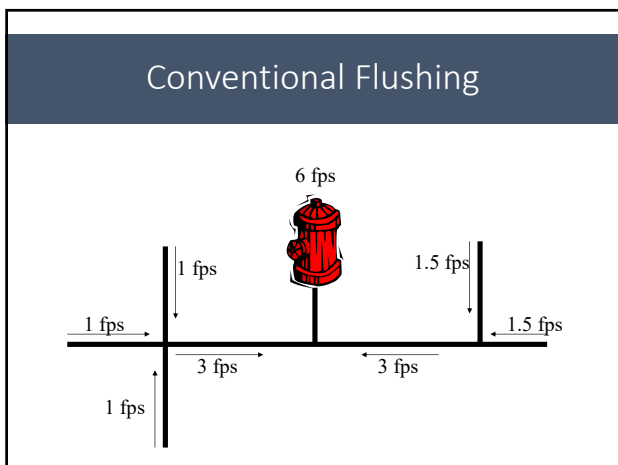

### Unidirectional Flushing

- Needs some engineering
- You control
  - Flow
  - Direction
    - Where the water is coming from and where it is going
- You have to know your distribution system
  - Know location of all mains, valves and hydrants

### Unidirectional Flushing

- Pros
  - Uses 40% less water than conventional flushing
  - Scours and cleans pipes up to 2 years
  - More localized
  - Tests most valves and hydrants
    - Identifies those that need repair or replacement

### Unidirectional Flushing

- Requirements:
  - Distribution maps and plans
  - Chart flow directions
  - Examine depletion and replenishment patterns of storage tanks
  - Review components
    - Tanks, hydrants, blow off valves, pipe material and pump stations

### Unidirectional Flushing

- Divide into sections (manageable loops) that will be flushed in sequence
  - Flushing runs
    - Set target for flushing velocities 2-5 fps
      - Remove biofilm
      - Don't stress weak areas
  - Develop step-by-step flushing sequence
    - Which hydrant or blow off valve to open and which valve to open or close

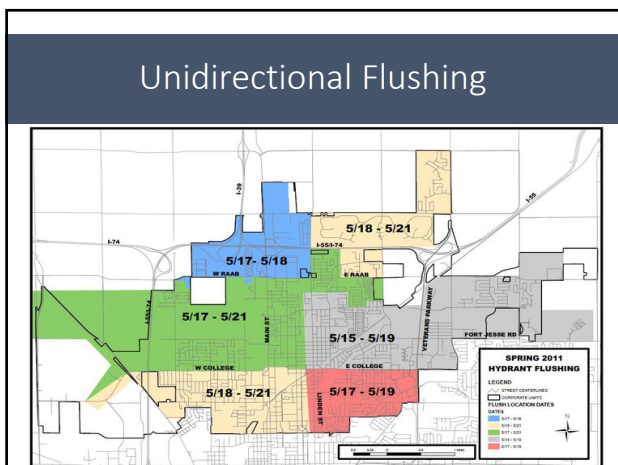

### Unidirectional Flushing

- Start from beginning - treatment plant or storage tank
- Isolate pipes you want to flush - close valves
- Flush from clean to dirty pipes
- Force water from bigger main to smaller main
- Sample water before, during and after

## Unidirectional Flushing



- Safety
  - Use a diffuser to decrease water velocity
  - Dechlorinate if chance of getting into surface water
  - Open valves and close them slowly so you don't create water hammer

## Unidirectional Flushing

- Safety - Continued
  - Wear appropriate clothing so people will see you
  - Watch traffic
  - Be careful when flushing hydrant, you don't know what could come out of it



## Unidirectional Flushing

- Restored disinfectant residual
- Reduces disinfectant demand
- Reduces bacterial growth
- Dislodges biofilms
- Removes sediments and deposits
- Restores flows and pressures
- Eliminates taste and odor problems

## Documentation

- You should document each time you flush a line
  - Location
  - Beginning of flush
    - Color of water
    - Residual chlorine
  - End of flush
    - Color of water
    - Residual chlorine
  - Time flushed
  - Rate of flow



Use an entry of these values as indicated to account for all the water used for flushing each year. Annual flushing records are required for all water utilities. (USE THIS FORM INSTEAD OF THE AEP) Attach the record to your Annual Report.

## Notify Customers

- You should notify your customers that you will be flushing lines in their area
  - Bill stuffers
  - Media - news papers, new stations
- They should be told that their water may be discolored but to let their cold water run until water is clear
  - They shouldn't use colored water for laundry, cooking or drinking
  - Don't use hot water to flush lines, they could end up with colored water getting into their water heaters

# Wet Barrel Hydrant

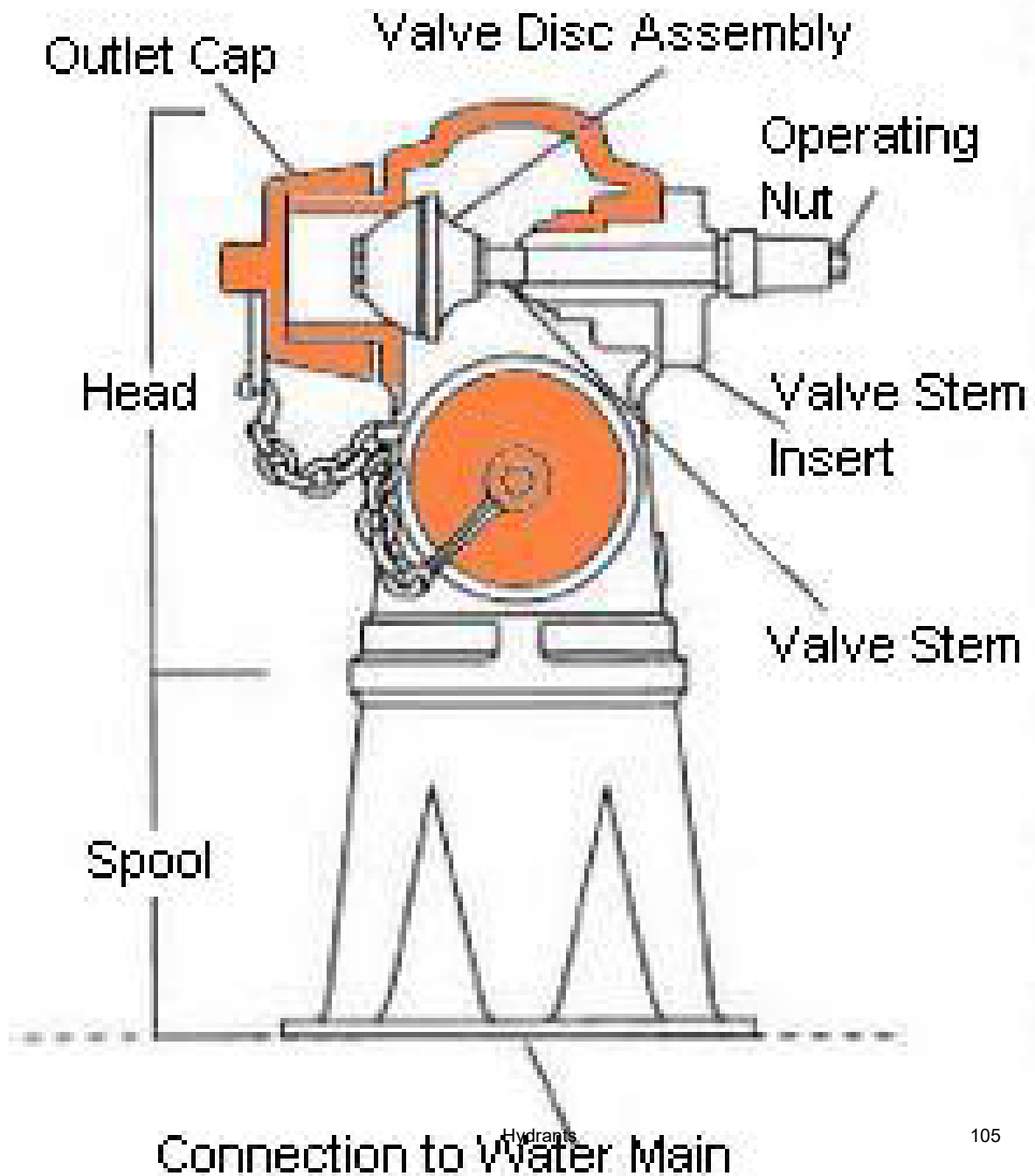

# Dry Barrel Hydrant

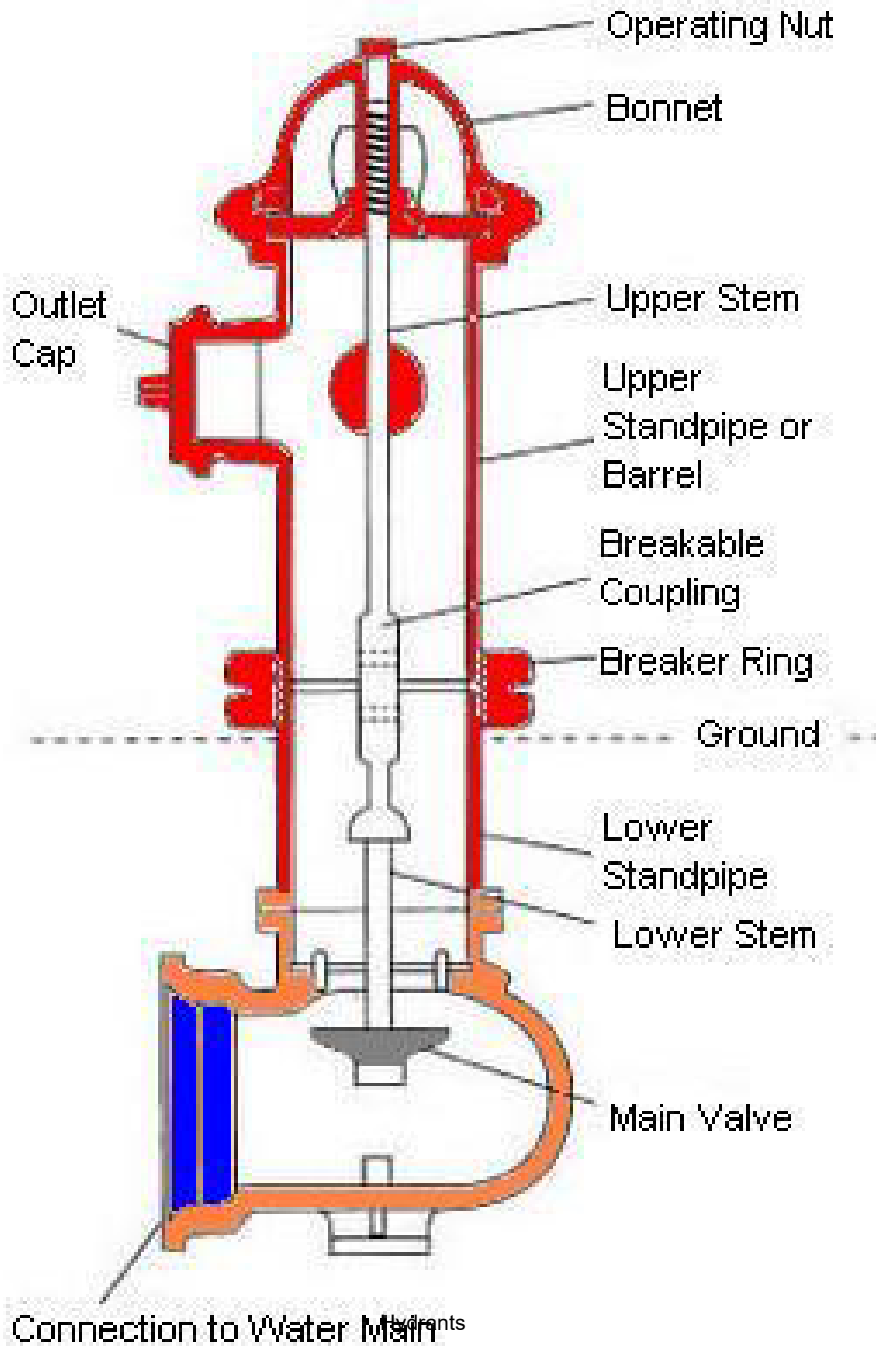

# Corey Hydrant

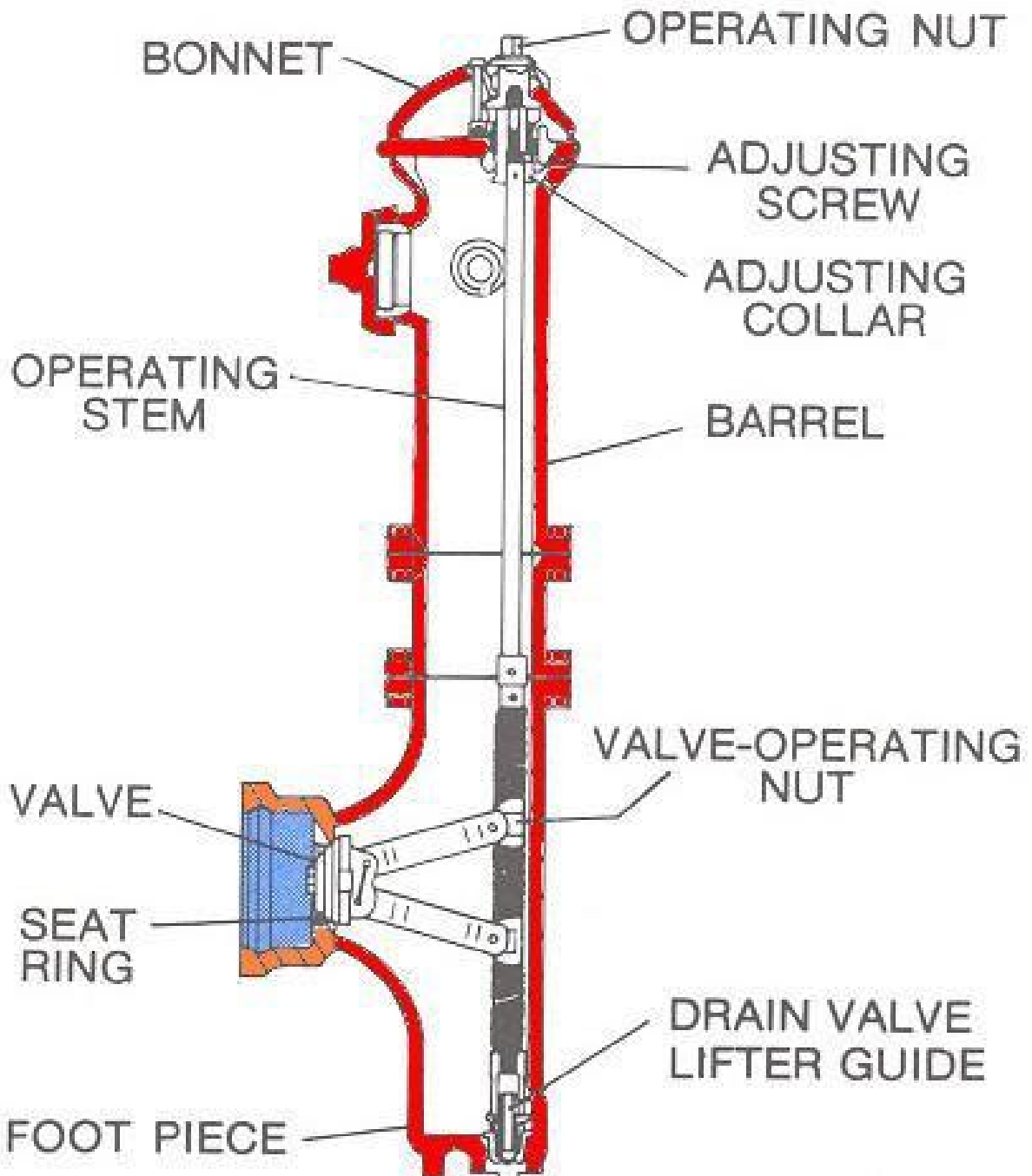

# Flush Hydrant

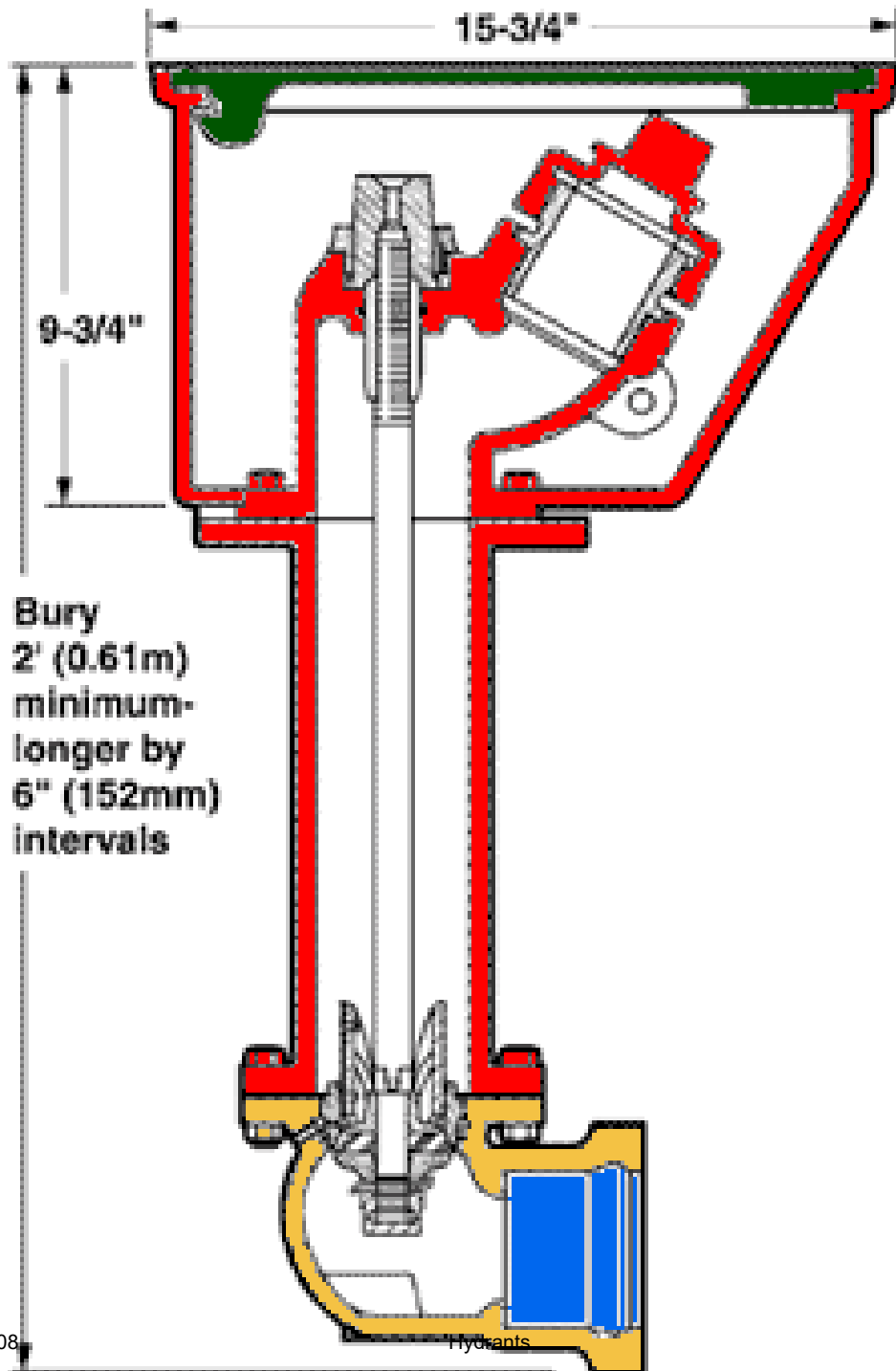



# Lower Section

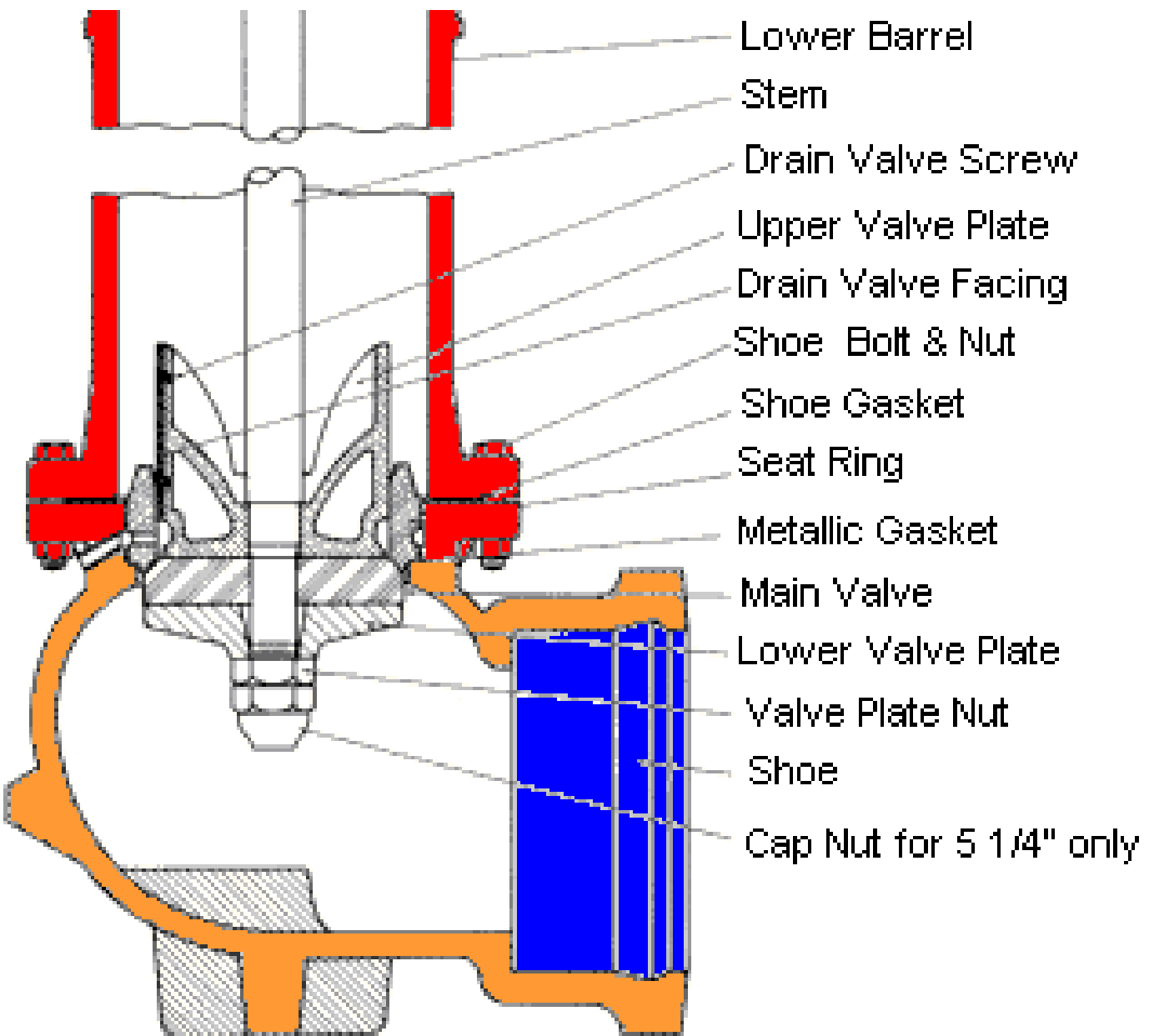

# Installation

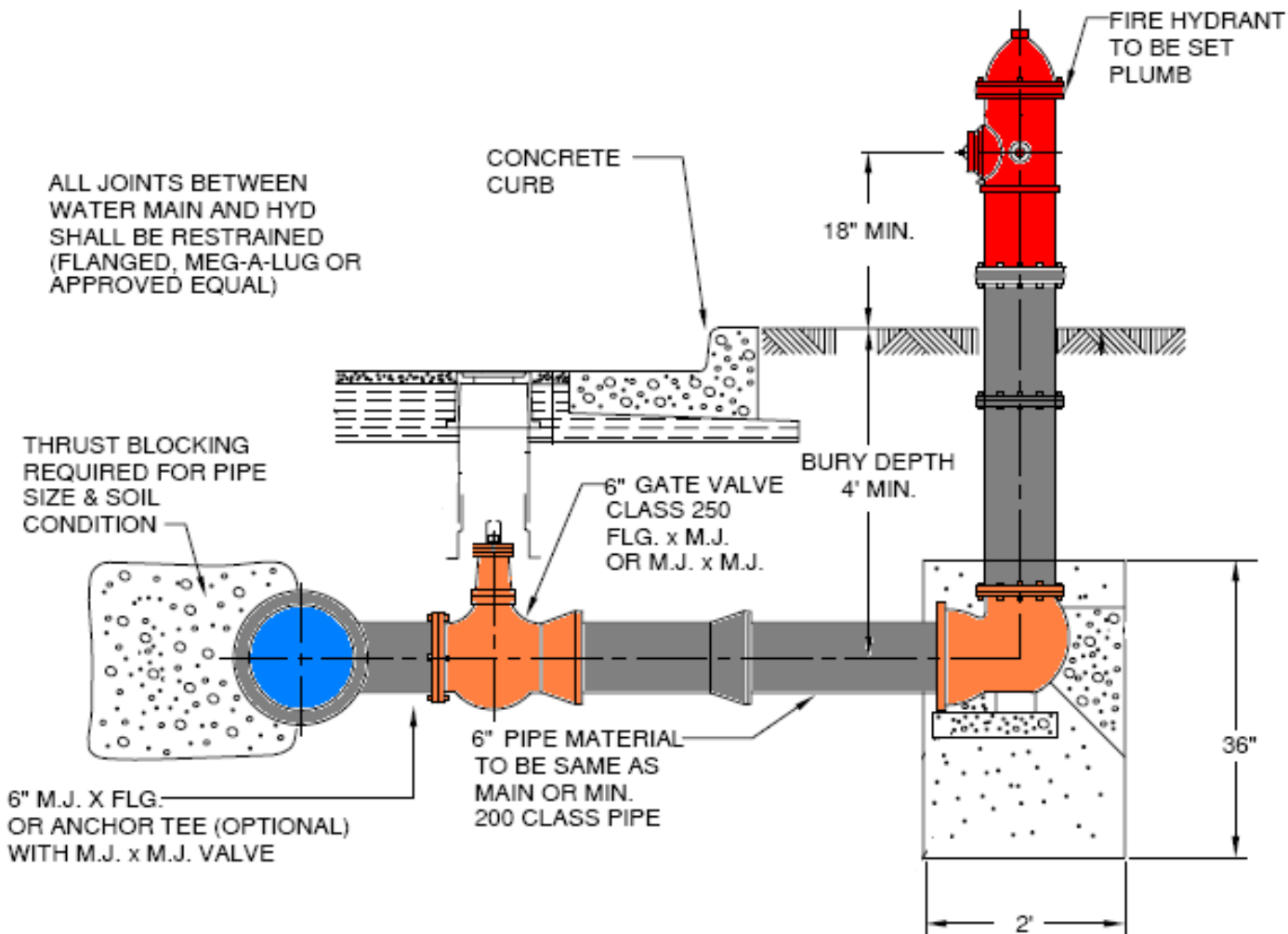

# FIRE HYDRANT MAINTENANCE

Ernie Milteer, District Sales Manager

M&H / Kennedy Valve Company

P- 615.347.5815 F- 615.382.9079 E- e.milteer@comcast.net

## GENERAL

All fire hydrants currently being installed in the south are in compliance with the American Water Works Association (AWWA) C502 standard for dry barrel hydrants, latest addition. Center stem compression hydrants are designed to both minimize maintenance needs as well as facilitate maintenance operations when necessary.

The following general information covers key mechanical components that may apply to all AWWA C502 hydrants. It is suggested to reference the manufacturers maintenance manual that is specific to each hydrant model for further servicing information.

When replacement parts are required, it is essential to provide detailed information specific to the subject hydrant. The following information for identification will be on the barrel section: 1) name of manufacturer, 2) model number, 3) year of manufacture, and 4) main valve size. Direction to open and depth of trench may also be applicable.

## MAIN VALVE

The most common maintenance need relates to obstructions in the seating area and resulting damage to the main valve. This is detectable by continued flow with the hydrant in the closed position.

When obstructions to seating of the main valve occur, it is important to avoid the use of excessive force in attempts to achieve closure. Excessive closure torques can accelerate damage to the main valve or induce damage to other related parts. The suggested procedure is to reopen the hydrant and flush the obstructions clear and attempt to re-close. If this is unsuccessful, the main valve assembly will need to be removed for further analysis.

Since we are going to remove the main valve, we must first turn off the auxiliary valve. Some maintenance functions can be performed under water pressure, however, when using a seat removal wrench we must confirm that the hydrant is not under pressure.

**DISASSEMBLY** - To access the main valve, the hydrant is disassembled starting from the bonnet. In the case of a grease-lubricated hydrant, we remove the bonnet bolts and thread off the bonnet unit off the stem. Next we remove the seal plate if applicable. In the case of an oil-lubricated hydrant, the manufacturer recommends removal of the operating nut assembly and procedures for retaining the oil in the bonnet.

Next, use the appropriate seat wrench (again with the water off) to remove the seat assembly. For recent production hydrants, this wrench engages on the cast iron break coupling below the break point or to an upper stem drive pin.

Most new model hydrants have bronze to bronze seating (seat ring to sub-seat). Also, the current use of O-ring seals provides servicing advantages verse old gasket seals. This allows for torque applied to the stem assembly to be sufficient drive out the seat ring.

For older models with a seat ring threaded into cast iron shoe, a longer seat wrench that drives directly on seat ring drive lugs is required to deliver disassembly torque. When encountering excessive resistance to seat removal, safety considerations increase in importance - especially when excessive manual force is employed. The wrench can be secured to the seat ring drive lugs by a retention device threaded to the upper stem. This can prevent the wrench from releasing while manual force is employed. Use of gear or power driven wrenches are preferable to the use of manual forces.

Main valve replacement is accomplished after removal of the bottom plate. Match the corresponding tapered seating surfaces of the main valve and the seat ring. At this point, also check the bronze-seating surface for damage. Minimal roughness can generally be buffed out with an emery cloth.

## **DRAIN VALVE SYSTEM**

Function of the drain valve system needs to be checked for proper operation. There are two primary issues that can cause a need for related maintenance.

- 1) Hydrant barrel fails to drain after use - which subjects it to freeze damage.
- 2) During full open hydrant operation, continuous discharge of water is taking place which can undermine support for the installation.

To accommodate barrel drainage, a gravel sump is installed around the base of the hydrant to accept water from the drain ports. To check for proper drainage, view the water level drop and/or feel for the suction created at the nozzle outlet. If the hydrant barrel fails to drain there are several possibilities to review:

A) Improper installation of a concrete thrust block over the drain ports is somewhat common with new installations. It is also possible that the poly-wrap used to encase the piping system does not allow for drainage. In either case the need for re-excavation makes the remedy somewhat difficult.

B) There also have been cases where a high water table is the culprit.

C) It is possible the weep holes have become plugged with sand etc over time or during construction. There are two ways to check or remedy this situation.

- 1) The first option is to attempt to force flush the drain system clear with water pressure. To attempt this, remove a hose cap and open the hydrant slightly and fill hydrant barrel as much as possible. (This step is intended to minimize hazards associated with compressed air inside the hydrant.) Turn off hydrant and tightly secure all hose caps. Open the hydrant approximately 3 turns - standing behind and not over when operating. This allows

line pressure to enter the hydrant while the drain system is open creating an opportunity for line pressure to blow the drain system clear.

2) If problems persist, CLOSE the auxiliary valve and remove the main valve assembly as noted above. Pump the remaining water from the hydrant barrel. Using a long narrow pole with a nail thru the end, locate the drain ports that exit the shoe and attempt to mechanically clear the drain ports.

If the above least difficult remedies are not successful, it is sometimes chosen to designate a hydrant to be pumped out after each use - rather than excavating to address the external drain area. A so designated hydrant should be regularly inspected - since very minor seat leakage may be retained in the barrel section and is subject to freezing.

If during hydrant operation, continuous discharge of water is taking place, note the following possibilities:

A) Hydrant needs to be operated in the full open position only. This assures that the drain valve facing is fully blocking the drain valve port.

B) The drain valve facing is damaged or missing. This is most common with older style hydrants using leather drain valve facings, which are subject to wear, swelling, shrinking & cracking.

The newer pressure activated rubber drain valve facings have been a great improvement to hydrant operations & maintenance. These allow for operational tolerances, which have virtually eliminated wear and resulting, service needs.

C) Inspect the drain valve assembly. This can be subjected to damage from disassembly torques being transmitted thru - and twisting of - the drain ears.

**REASSEMBLY** - To reinstall the main valve assembly, inspect the O-ring seals and replace if necessary. For hydrants with older style gasket type seals, gasket replacement with each servicing is recommended. Clean the threads and apply food grade grease to the O-rings or gaskets and seat ring threads.

Lower the stem and main valve assembly into the barrel - using caution to avoid scrapping or dislodging the O-rings or gaskets. To assure proper starting of the threads, use the wrench to rotate assembly backwards one or two turns to align seat ring threads before threading into place. On models with O-ring seals, only a moderate amount of torque is required to seal the O-rings.

Before applying pressure to the main valve assembly, the bonnet assembly must first be installed. This permits valve closure to be regulated by the operating nut. Do not flush a partially disassembled hydrant without the restraint of the operating nut assembly – since this would allow flow to drive the main valve closed and create a water hammer situation.

## STEMS

Bronze upper stem sleeves should be inspected. The stem sleeve is bronze - since bronze is non corrosive and won't cut the bonnet / seal plate O-rings as the stem rises & descends during operation. However, bronze is a relatively soft material and subject to mechanical damage. To inspect, shut off the hydrant lead gate valve – remove the pumper cap - and open the hydrant. At this point the stem sleeve is just about fully visible and any damage should be detectable.

## BREAKAWAY SYSTEM

The breakaway system is the weak point designed to fracture upon impact. This minimizes potential damage to the hydrant, the vehicle, and its occupants. Alternately, the break system must have enough structural integrity to facilitate high flow fire fighting operation. Due to potential for minor impact or bump damage, it is very important to perform a visual check of break flanges or break lugs as part of routine maintenance.

Finish grade shall be a minimum of 18 inches from center on pumper nozzle. This is essential for proper performance in the event of a collision. A well supported installation plays a key role in proper break function – in that the impact stress will be more fully focused on the cast iron break away components in a ridged installation rather than transferred to other points in the hydrant assembly.

After a collision - repair can be accomplished as follows:

- 1) Removing broken coupling and standpipe break rings or break lugs.
- 2) Unscrew the upper stem from the operating nut
- 3) Install the new break coupling and replace upper stem.
- 4) Remove the cap/bonnet assembly.
- 5) Reassemble upper barrel of hydrant to lower barrel - checking to assure proper gasket/o-ring gasket installation.
- 6) Install breaker rings or break lugs - tighten evenly to manufacturer's recommended torques.
- 7) Replace the cap / bonnet assembly by fully threading onto the upper stem and tighten bolts/nuts.
- 8) Add lubrication as recommended by the manufacturer.

## EXTENSIONS

If the break system is not located in the recommended range, an extension should be added to help assure its breakaway function. This also permits the fire department to efficiently use cap wrenches and attach hoses.

*Please use original manufacturer extensions* to assure proper stem assembly tolerances. Upward thrust (especially at higher pressures) can cause stem deflection. An extended hydrant with two (or more) stem couplings that are too loose or have improper pins will greatly increase the potential for stem deflection and operational failure.

## LUBRICATION & OPERATING NUT

The stuffing box area - located between the stem lock nut and the machined bonnet - contains the thrust collar of the operating stem nut. Line pressure provides resistance to initial opening of the main valve - which is transmitted as upward thrust to the op nut thrust collar - forcing it up against the stem lock nut.

Teflon thrust washers have been used over the past 35 +/- years to reduce operating friction. Hydrants with full travel stiff operation are usually older hydrants lacking a thrust washer and/or weather-shield protection of the op nut. Retrofitting a thrust washer is a relatively easy and inexpensive way to greatly improve operation of older hydrants.

Access to the operating nut is achieved after removing the stem lock nut. The stem lock nut is designed with backwards threading (for open left hydrants) - which tends to tighten while absorbing the thrust of opening of the hydrant against water pressure.

Before installing the retrofit washer, clean the stuffing box area. If contacting surfaces have become excessively scored, the bronze parts may need to be replaced or refaced. After installation of the washer, be sure enough tolerance exists for operation without binding. Slight machining of the stem lock nut can provide additional tolerance for installation, if required.

After reinstalling the operating nut and stem lock nut, be sure the stem lock nut is fully threaded into the bonnet and retention hardware is engaged. This will prevent the lock nut from backing out while closing the hydrant.

Other possible causes of stiff operation would relate to the remaining operational contact points. These should be limited to:

- A) Damaged op nut threads
- B) Stem interference through the bonnet or seal plate.
- C) Drain valve components that travel within the seat ring.

Hydrant manufacturers recommend lubrication of the operating nut either by grease or oil. Regardless of the type of lubricant, use of a NSF food grade lubricant is essential. (Be sure to use a food grade lubricant that *DOES NOT* contain Calcium Acetate.) The need for a food NSF grade lubricant is driven by concerns relating to possible contamination of the water system from the use of an automotive petroleum product. Lubrication access is provided by either an alemite fitting or fill plug.

## NOZZLES and CAPS

There are many types of mechanical retention systems used to secure the nozzles to the hydrant upper. Current production models use stainless steel set screws, pins or wedges - in conjunction with 1/4 turn or threaded nozzles.

Caps should be checked to be sure they are not seized to the nozzles. Nozzles (and adaptors) need to be checked to be sure they are properly secured to the hydrant. Also, confirm the nozzle threads match the equipment used by the local fire department.

Removal & replacement of nozzles can be challenging on older hydrants with corrosion and/or dysfunctional retention systems. If all else fails, carefully cut into the bronze only with a saw-saw and collapse the old nozzle with a hammer. Follow the manufacturer's recommendations for nozzle replacement and retention.

O-ring seals are generally used for sealing to the nozzle section. Gaskets are used to provide a seal to the caps.



## Hydrant Maintenance Report and Test Data

Hydrant No. \_\_\_\_\_ MVO \_\_\_\_\_" Mfgr. \_\_\_\_\_ Year Cast \_\_\_\_\_ Installed \_\_\_ / \_\_\_ / \_\_\_

Location \_\_\_\_\_

Hose Caps Missing \_\_\_\_\_ Replaced \_\_\_\_\_ Greased \_\_\_\_\_ Gaskets \_\_\_\_\_

Pumper Caps Missing \_\_\_\_\_ Replaced \_\_\_\_\_ Greased \_\_\_\_\_ Gasket \_\_\_\_\_

Cap Chains Missing \_\_\_\_\_ Replaced \_\_\_\_\_ Freed \_\_\_\_\_

Nose Noz Threads 2 1/2" NST \_\_\_\_\_ Other \_\_\_\_\_ Recaulk \_\_\_\_\_ Replaced \_\_\_\_\_

Pump Noz Threads 4 1/2" NST \_\_\_\_\_ Other \_\_\_\_\_ Recaulk \_\_\_\_\_ Replaced \_\_\_\_\_

Operating Nut Condition \_\_\_\_\_ Greased \_\_\_\_\_ Replaced \_\_\_\_\_ No. Turns \_\_\_\_\_

Valve & Seat Condition \_\_\_\_\_ Replaced \_\_\_\_\_

Stem Packing/O-Rings Condition \_\_\_\_\_ Tightened \_\_\_\_\_ Replaced \_\_\_\_\_

Drainage Condition \_\_\_\_\_ Corrected \_\_\_\_\_

Paint Condition \_\_\_\_\_ Repainted \_\_\_\_\_

Branch Valves Condition \_\_\_\_\_

Other Defects/Corrections \_\_\_\_\_

Flushed Minutes \_\_\_\_\_ Nozzle Open \_\_\_\_\_

Pressure Static \_\_\_\_\_ psi Residual \_\_\_\_\_ psi Flow \_\_\_\_\_ gpm Flow \_\_\_\_\_ psi

Inspected By: \_\_\_\_\_ Date: \_\_\_\_\_

Corrections By: \_\_\_\_\_ Date: \_\_\_\_\_

### Flushing Program Record

Date	Time	Location or Address	Type of Valve or Hydrant	Time to Clear	Total Time	Flow (gpm)	Free Chlorine Residual	Persons Responsible

## Fire Hydrant Vocabulary

- |                       |                         |
|-----------------------|-------------------------|
| A. Barrel             | I. Fire Hydrant         |
| B. Base               | J. Operating Nut        |
| C. Bonnet             | K. Outlet Nozzle        |
| D. Breakaway Hydrant  | L. Pitot Gauge          |
| E. Cap Nut            | M. Pumper Outlet Nozzle |
| F. Corey Hydrant      | N. Residual Pressure    |
| G. Dry Barrel Hydrant | O. Water Hammer         |
| H. Fire Flow          | P. Wet Barrel Hydrant   |

- \_\_\_\_\_ 1. A device connected to a water main and provided with the necessary valves and outlet nozzles to which a fire hose may be attached.
- \_\_\_\_\_ 2. A two-part, dry barrel post hydrant with a coupling or other device joining the upper and lower sections. The hydrant is designed to prevent water loss in the even it is struck by a vehicle.
- \_\_\_\_\_ 3. A type of dry barrel hydrant in which the main valve closes horizontally and the barrel extends well below the connection to the pipe.
- \_\_\_\_\_ 4. The body of a fire hydrant.
- \_\_\_\_\_ 5. A nut, usually pentagonal or square, rotated with a wrench to open or close a valve or fire hydrant valve.
- \_\_\_\_\_ 6. The inlet structure of a fire hydrant; it is an elbow shaped piece that is usually constructed as a gray cast-iron casting.
- \_\_\_\_\_ 7. The potentially damaging slam that occurs in a pipe when a sudden change in water velocity creates a great increase in water pressure.
- \_\_\_\_\_ 8. A hydrant with the main valve located at the base. The barrel is pressurized with water only when the main valve is open.
- \_\_\_\_\_ 9. A threaded bronze outlet on the upper section of a fire hydrant, providing a point of hookup for hose lines or suction hose from hydrant to pumper truck.
- \_\_\_\_\_ 10. A large fire hydrant outlet, usually 4.5 inches in diameter, used to supply the suction hose for fire department pumpers.
- \_\_\_\_\_ 11. The top cover or closure on the hydrant upper section, which is removable for the purpose of repairing or replacing the internal parts of the hydrant.
- \_\_\_\_\_ 12. A device for measuring the velocity of flowing water by using a velocity head of the stream as an index of velocity.
- \_\_\_\_\_ 13. A fire hydrant with no main valve. Under normal, nonemergency conditions the barrel is full and pressurized.
- \_\_\_\_\_ 14. Connects a standard-compression hydrant valve assembly to the hydrant main rod.
- \_\_\_\_\_ 15. The pressure remaining in the mains of a water distribution system when a specified rate of flow, such as needed for fire fighting purposes, is being withdrawn from the system.
- \_\_\_\_\_ 16. The rate of flow, usually measured in gallons per minute, that can be delivered from a water distribution system at a specified residual pressure for fire fighting.

## Review Questions

1. List four commonly authorized uses for fire hydrants, other than for fire protection:



2. List four reasons why strict controls should be exercised over hydrant uses:



3. How can operation of a fire hydrant cause water quality problems?

4. Explain the principal difference between a dry barrel and a wet barrel hydrant.

5. In relation to the street, what direction should the pumper nozzle be pointed?

6. List two ways hydrants can be protected from damage by traffic:



7. What is the purpose of a color-coding scheme for hydrant tops or caps?

8. Why is the speed at which hydrant valves are operated important?
9. Name three preventative measures that should be taken in cold climate areas to ensure that hydrants will remain operable during the winter.
- - 
  -
10. List three items of information about the distribution system that can be obtained from hydrant flow test.
- - 
  -
11. List seven items of information that should be included on a hydrant record form:
- - 
  - 
  - 
  - 
  - 
  -
12. Name five safety precautions that should be taken during hydrant flushing and testing to prevent injury to personnel and the public and to minimize damage to property.
- - 
  - 
  - 
  -

## Answers

### Vocabulary

- |      |       |       |
|------|-------|-------|
| 1. I | 7. O  | 13. P |
| 2. D | 8. G  | 14. E |
| 3. F | 9. K  | 15. N |
| 4. A | 10. M | 16. H |
| 5. J | 11. C |       |
| 6. B | 12. L |       |

### Review Questions

1. flushing water mains, flushing sewers, filling tank trucks, providing temporary water source for construction work
2. **(I)** To limit the amount of water that is wasted or not paid for  
**(II)** To keep a close control on unmetered water to limit the amount of unaccounted-for water  
**(III)** To minimize damage to hydrants caused by improper operation, such as incomplete valve closing or use of an improper wrench  
**(IV)** To reduce the possibility of distribution system demand due to such improper hydrant operation as closing a hydrant too quickly and causing water hammer
3. Increased flow in the main can stir up sediment, causing discolored or cloudy water.
4. The dry barrel hydrant has its main valve in the base. The barrel is dry until the valve is opened. When the main valve is closed, the barrel drains to prevent freezing.  
 The wet barrel hydrant has no main valve in the hydrant (although there is usually an auxiliary valve). Each outlet nozzle has an independent valve that controls its discharge. The barrel is full of water under pressure at all times when the hydrant is in service.
5. The pumper nozzle should always be pointed toward the street so that the fire department can use a hard suction hose connected to the pumper truck.
6. Set hydrants back from the edge of the pavement and install hydrant guard posts.
7. A color-coding scheme is commonly used to indicate the hydrant flow capacity or the size of the water main. It is not used to indicate main pressure.
8. Hydrants should be opened and closed slowly in order to prevent pressure surges (water hammer) in the mains.
9. **(I)** Inspect hydrants in the fall to make sure their barrels are drained.  
**(II)** Inspect hydrants after each use in freezing weather, and pump out the barrel of any hydrant that does not drain properly.  
**(III)** If any hydrants are found to be inoperable, mark them by putting something over them, and notify the fire department of the locations.
10. **(I)** The need for additional feeder or looping mains  
**(II)** The need to clean existing pipes  
**(III)** Identify system valves that have been inadvertently left closed

11. name of the manufacturer; type or model; date installed; location (street address, plus distance ties to several permanent markers); buried depth; outlet-nozzle sizes and thread types; inlet pipe size
12. (I) Take care that the water force does not injure workers or pedestrians.  
(II) Consider possible traffic hazards.  
(III) Take special precautions if the water may freeze.  
(IV) If flow is diverted with a hose to a sewer, take care not to create a cross-connection.  
(V) If flow is diverted with a hose, the end of the hose must be securely anchored.





## **Section 8**

### **Water Services & Meters**



# Water Meters

## Objectives

- Service Lines
- Water Metering
- Types of Water Meters
- Meter Selection
- Meter Installation
- Meter Testing, Maintenance, and Repair

# Water Services



## Water Service Lines

- Water service lines are the pipes that lead from a connection on a water main to a connection on a customer's plumbing.
- Line size depends on:
  - Maximum water demand
  - Main pressure under peak demand conditions
  - Elevation difference between main and the highest portion of the building to be served
  - Distance from main to building plumbing

## Water Service Lines

- Single family residences usually have ¾-inch service line
- Other customers have service line sized for max demand
- Types:
  - Lead pipe
  - Galvanized iron pipe
  - Copper tubing
  - Plastic tubing

## Lead Pipe

- Most older systems still have some lead service connections in use
  - Usually replaced, not repaired
  - The principal reason for such a policy is that evidence points to health risks due to lead leached from plumbing materials

## Galvanized Iron

- Connected with gooseneck for flexibility
- Subject to galvanic corrosion, corrosion from soil
  - especially at a pipe connected with brass fittings
- Usually replaced rather than repaired

## Copper Tubing

- Popular replacement for lead and galvanized iron because:
  - It is flexible
  - Easy to install
  - Corrosion resistance in most soils
  - Able to withstand high pressure
- Aggressive water may dissolve copper, to cause green stains on plumbing fixtures

## Plastic Tubing

- Three generally used for water services
  - PVC (polyvinyl chloride)
  - PE (polyethylene)
  - PB (polybutylene)
- Low friction, lightweight, corrosion resistant
- Permeable by gasoline, solvents, etc.
- Cannot be located by electronic pipe finder
- Must have NSF approval seal



## Installation

- Service line starts at main with corporation stop
  - Water service shutoff valve located at the street main
  - Service line should be flexible
  - Connects to another water shutoff valve (curb stop) which is attached to meter
    - Located near curb and between the water main and the building
  - Where contamination is possible install backflow prevention device between meter and customer's line



## Corporation Stops

- Valve used to connect a small-diameter service line to a water main
- Also known as
  - Corporation cock
  - Corporation tap
  - Corp stop
  - Corporation
  - Corp
  - Stop
- Available with a ball valve or plug valve

## Curb Stops and Boxes

- Curb stop
  - shutoff valve to meter
- Curb box
  - pipe extending from curb stop to surface
  - allows access to curb stop with a key
- Plug or ball valve

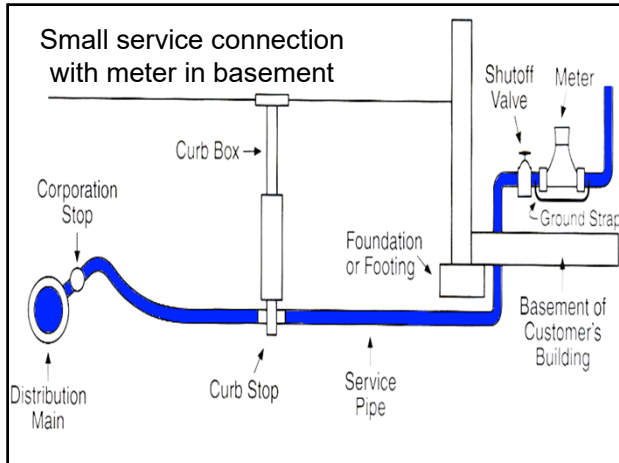

## Water Service Taps

- **Dry taps**
  - Made during installation of new main
  - Water main is empty
- **Wet taps**
  - Water main is filled with water under pressure
  - Addition to an in-service main
  - Connection made without shutting off water
  - No contamination of line

## Direct Tapping

- **Ductile Iron**
  - Corporation stop can be directly screwed into a threaded hole in pipe wall
    - *AWWA threads* has more of a taper than typical
- For PVC and A-C, carefully follow manufacturer's instructions
  - Steep taper of corporation stop make over tightening of the valve an issue that can damage pipe or strip threads
- All taps large than 1 inch made on any type of pipe 6 inches or smaller should be made through a saddle

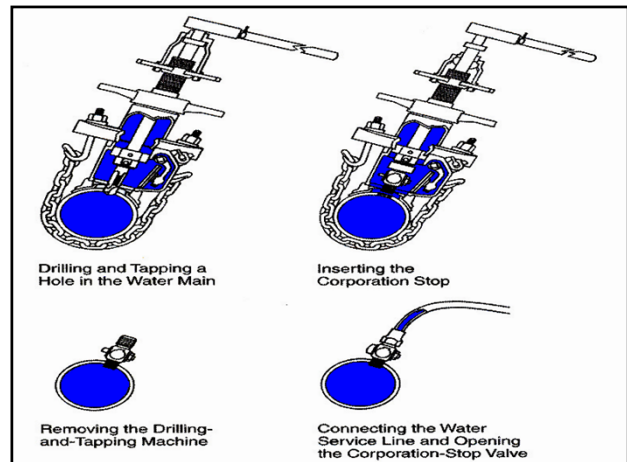

## Direct Tapping Process

- Pipe excavated and cleaned; machine clamped into place
- Machine bores hole in pipe wall, tap cuts threads
- Boring bar retracted; flapper valve closes to contain pressurized water
- Drill-and-tap tool removed, corporation stop threaded into hole in closed position
- Bar is reinserted into the machine and the corporation stop is screwed into the threaded hole
- Machine is removed; corporation stop is ready for attachment of service line

## Tapping Competition



### Service Clamps

- Also known as service saddles
- For taps larger than 1 inch on PVC or A-C, a service clamp should be used instead of a direct tap
- Eliminates chance of pipe splitting or corporation stop threads not holding

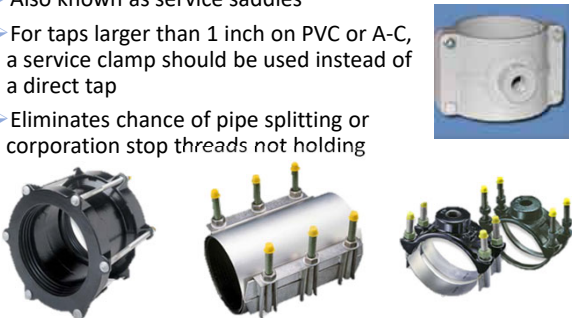

### Tap Location

- 45° angle down from top of main
  - A tap directly on top is more liable to draw air in the service
  - A tap near the bottom could draw in sediment
- On same side of main as building
- S-curve of service line allows for pipe expansion and contraction

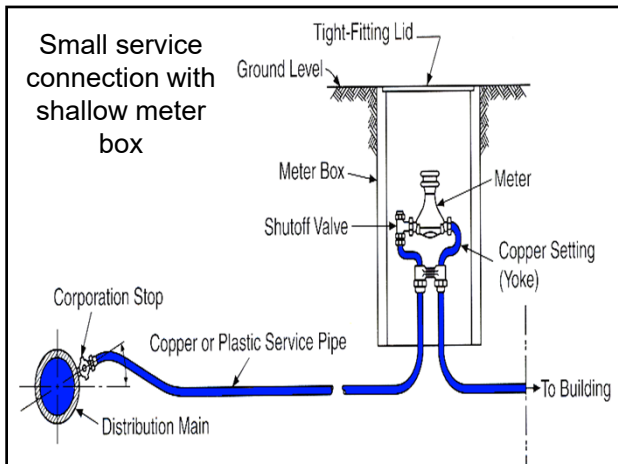

### Leaks and Breaks

- Old lead and galvanized pipes tend to have more small leaks
  - Lead pipes typically at the curb stop
    - Caused by valve movement or weight applied to box at surface
  - Galvanized pipe likely to leak after being disturbed
  - Best to replace and not repair lead and galvanized pipes
- Copper and plastic rarely have small leaks
  - Caused by being pulled from a fitting by ground settlement or cut by adjacent excavation

### Thawing

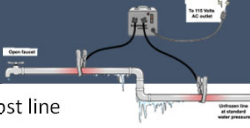

- Prevent freezing by burying below frost line
- Metallic pipe can be thawed by electric current
  - Current run through a pipe and resulting heat melts ice
  - Can damage pipe, O-rings, gaskets, soldered joints
  - By experienced operator
- Hot water thawing less dangerous and can be used for any type of pipe
  - Pump hot water through a tube into service line
- Hair dryer or heat gun will thaw meter or service line in meter box

### Service Line Records

- File by address - card or computer
  - Exact location of tap
  - Type & size of pipe & tap
  - Bury depth
  - Location of curb stop or meter box
  - Location of pipe entry to building
  - Date of installation
- Good records on plastic pipe are especially important because they cannot be located by electronic equipment

## Water Metering



## Water Meters

- Measure and record the amount of water passing through
- Primary functions are
  - To help water utility account for water pumped to system
  - Charge customers for the water they use

## Water Meter Requirements

- Leak tight
- Upstream shutoff valve of high quality with low pressure loss
- Positioned on horizontal plane
- Reasonably accessible
- Easily read
- Protected against from frost, damage, or tampering
- Must not be an obstacle or hazard after installation

## How do we measure water?

- By volume
  - Filling and emptying a calibrated space
  - Positive displacement meters
    - 2" and smaller meters only
- By velocity
  - Measuring the speed water moves
  - All sizes, residential and commercial
  - Current, velocity, magnetic, sonic, or proportional meters

## Meter Purpose

- Every water service should have a meter on it
  - Payment purposes
  - Account for water pumped to distribution
  - Help locate water leaks

Incorrect metering accounts for the second greatest loss of water to a utility

## Types of Water Meters



### Types of Meters

- Low-flow meters (positive displacement)
  - Nutating disc
  - Piston
- High-flow meters (velocity)
  - Turbine
  - Propeller
  - Venturi
  - Electronic
  - Insertion
- Combination meters (compound)

### AWWA Standards

- C700 - Displacement Meters
- C701 - Turbine Meters
- C702 - Compound Meters
- C703 - Fireline Meters
- C708 - Multi-Jet Meters

### Positive-Displacement Meters

- Most commonly used meter for residences and small commercial
- Reliable and accurate for low flow rates
- Measure exact quantity of water passing through it
- Positive displacement meters use a calibrated space that is filled and emptied to measure water
  - Measuring cup
- There are 2 types of positive displacement meters
  - Nutating Disc
  - Oscillating Piston

### Positive-Displacement Meters

- Piston meter
  - Piston moves back and forth as water flows through
  - Volume known for each rotation & motion is transmitted through a magnetic drive connection and **PARS**

### Positive-Displacement Meters

- Nutating disk
  - Uses a measuring chamber with a flat disc
  - As water flows through, flat disc nutates (wobbles and rotates)
  - Sweeps out specific volume for each rotation (wobble)
  - Motion of disc is transmitted to register

### Positive-Displacement Meters

- Advantages
  - Accurate over wide range of flows
  - Easy to repair or replace due to availability
- Disadvantages
  - High head loss at high flow rates
  - Under register when worn; max usage should be half of capacity

## Velocity Meters

- Also called current meters
- Turbine, multijet, propeller, Venturi meters, etc.
- Measure velocity of flow past a cross-section of known area
- Can measure large quantities of water without damage to moving parts
- Low head loss ideal for high flow rates
- Inaccurate at low flow rates

## Velocity Meters

- Turbine and Propeller Meters
  - Rotors or propellers are turned by flow of water
  - Movement transmitted to register
  - Not designed for low flows or stop and go operation
  - Good for measuring continuously high flows and have low friction loss
  - Propeller meters can be installed within a pipe or saddle mounted



## Velocity Meters

- Venturi Meter
  - Does not interfere with flow of water if meter fails.
  - Consists of an upstream reduce, a short throat piece, and a downstream expansion section where the throat diameter increases
  - Water measured by comparing pressure at the throat and at a point upstream
  - Accurate over large flow range with little friction loss
  - Best meter to measure flow rate from a pump station

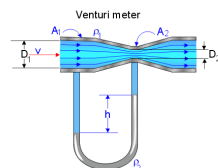

## Velocity Meters

- Orifice Plates
  - Insertion type meter with circular hole that is installed in pipeline between a set of flanges
  - Flow determined by comparing pressures upstream and at orifice restriction
    - Less expensive & take up less space than Venturi meters
    - More severe pressure losses & less reliable than Venturi meters

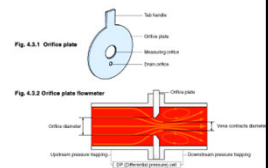

## Velocity Meters

- Multijet meters
  - Measure the speed of water passing through the calibrated measuring chamber
  - Use a horizontal rotor attached to a vertical spindle
  - Water moves through orifices in the measuring chamber wall and causes the rotor to spin
  - Orifice clogging leads to over registering
  - Orifice wear leads to under registering



## Large Water Meters

- Customers that use large quantities of water
  - Transfer or Utility purchases
  - Industries
    - Great deal of cleaning
    - Incorporate water into manufactured products
  - Businesses
    - Hospitals
    - Large public buildings
    - Apartments
  - Irrigation at golf courses
- Common meters used compound meters, current meters, detector-check meters



### Compound Meters

- For customers with wide variations in water use
- Turbine meter and a positive-displacement meter in one
- Automatic valve controls water flow through meter
  - High flows go through the turbine side with little restriction
  - Under low flows, the valve shuts and directs water through a small displacement meter
- High maintenance requirement, expensive

### Compound Meters

- When high flows are sensed, valve separating two measuring chambers is opened
  - Allows water to flow through turbine meter with less restriction
- Under low flows, valves close pushing water through smaller (positive displacement) meter
- Can have both chambers within one body or as two separate standard meters connected together



### Where are Compound Meters Used?

➤ Apartment Buildings	➤ Restaurants
➤ Motels	➤ Dormitories
➤ Hotels	➤ Department Stores
➤ Condominiums	➤ Shopping Malls
➤ Mobile Home Parks	➤ Public Transportation Centers
➤ Hospitals	
➤ Schools	

For Low to High Continuous Flow Rates

**Where people live and work!!**

### Detector-Check Meters

- For emergency high-use services
  - Example: fire sprinkler systems
- Weight-loaded check valve in main line is closed under normal flow, opens for high flow conditions
- Bypass around check valve has displacement meter

### Electronic Meters

- Magnetic (mag) Meters
  - Water flows through magnetic field creating small electric current proportional to water flow
- Sonic Meters
  - Sound pulses sent across pipe
  - Frequency of sound changes with velocity of water
  - Difference between frequency of sound signals measured

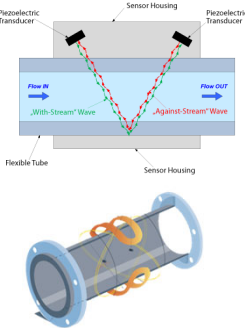

### Proportional Meters

- Portion of water diverted into a loop that holds a meter
- Diverted flow is proportional to flow in main line
- Relatively accurate, little friction loss, and little flow obstruction
- Difficult to maintain

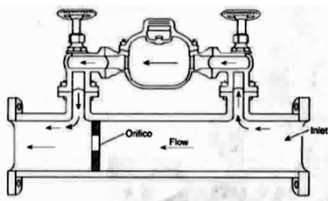

# Meter Selection





## Selecting the Right Meter

- Meter selection is the responsibility of the utility
- First, consider the application
  - Single family residence
  - Small commercial
  - Light industrial
  - Irrigation
- Each application should be considered by it's individual requirements

## Selecting the Right Meter

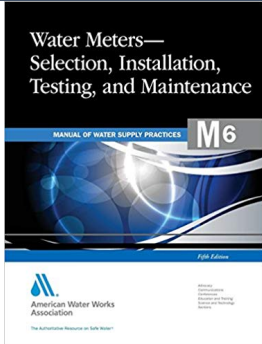
- Meter is usually one size smaller than service line
- For residential, start with 3/4 inch meter
- AWWA Manual M6 for sizing meters



## Selecting the Right Meter

- Proper sizing is important for accurate measurement
- Projected water use should be the primary selection criteria
  - Flow rate
    - What is the maximum and minimum expected flow
    - Maximum flow requirement is critical to meter selection
- Total usage should be considered
  - How much water per month is expected to be used

## Meter Size

- Improperly sized meters can lead to increased repairs or revenue loss
- Factors to consider
  - Range of flow rates
  - Pressure at service connection
  - Elevation differences between main and highest fixture in building
  - Friction losses

## Selecting the Right Meter

- Meter manufactures' literature provides flow ranges of their meters

SIZE	SAFE MAXIMUM OPERATING CAPACITY	NORMAL TEST FLOW	REQUIRED ACCURACY	MINIMUM TEST FLOW	REQUIRED ACCURACY
5/8"	20 GPM	1-20 GPM	98.5-101.5%	1/4 GPM	95%
3/4"	30 GPM	2-30 GPM	98.5-101.5%	1/2 GPM	95%
1"	50 GPM	3-50 GPM	98.5-101.5%	3/4 GPM	95%
1-1/2"	100 GPM	5-100 GPM	98.5-101.5%	1-1/2 GPM	95%
2"	160 GPM	8-160 GPM	98.5-101.5%	2 GPM	95%

## Meter Selection

- Determine the customer's actual requirements
  - A restaurant, for example
    - Do they wash dishes?
    - How many restrooms?
    - How many employees?
    - Do they irrigate landscape areas?
    - Will they have fire protection?

## Meter Selection

- Historical data from a business could help
  - If the customer is part of a chain or franchise operation, data from another store should help
  - Similar businesses can be used to help determine potential usage
- Remember, an oversized or misapplied meter will give away water!

## Meter Installation



## Meter Location

- Easier to access meter box than entering a building
- Deep meter pits may be subject to flooding
- In buildings - install in basement; make sure the homeowner cannot illegally tap line ahead of meter

## General Installation Requirements

- Meter should not be subject to flooding
- Upstream and downstream shutoff valves for isolation
- Always install horizontally
- Reasonably accessible for service and inspection
- Location should provide for easy reading
  - Either directly or via a remote reading device

## General Installation Requirements

- Needs protection against frost, vandalism, tampering
- Should not be an obstacle after installed
- Seals attached to register should be attached
- Large meters should be supported to prevent stress on the pipe
- Large installations require bypass for uninterrupted service during maintenance

## Installation

- Depth of meter box depends on maximum frost depth
- Requires straight pipe lengths upstream and downstream
- Mountainous regions may require pressure-reducing valve at meter

## Manifold (Battery) Installation

- For customers requiring high flows
- Allows continuous service during maintenance or replacement
- All meters and valves are same size
- All but one must have spring-loaded check valve
  - When the flow is small, only one meter will operate



## Indoor Installations

- Locate meter immediately after point where service line enters through floor or wall
- Location must be kept clear for easy access
- *More common in locations where temperatures get and stay very low*

## Outdoor Installations – Small Meters

- Meter pit standard size, located near property line
- Lid flush with ground, tight-fitting, tamper resistant
- Riser pipes should be 2 inches from walls
- Location and type of curb stop specified
- Recommend use of meter yoke to prevent damage over time, and facilitate removal

## Outdoor Installations – Large Meters

- No uniform standard
  - Must consider size and weight
- Must provide support for meter to prevent service line damage
- Test valves should be provided to allow for volumetric tests
- Refer to manufacturer's recommendations

## Meter Connections

- Meter sizes up to 1 inch usually have screw-type connections
- Flanged connections for larger meters
- Meter yoke or horn – holds stub ends of pipe that will hold meter in alignment and spaced as well as provide electrical continuity



## Meter Reading

- Record all numbers including fixed zeros or multiplier
  - The multiplier such as 10x or 1000x will be noted on the meter register face
- Direct Readout
  - Get reading from each meter
- Remote Reading Devices
  - Signal transmitted electrically from meter to a counter outside
  - Can plug a reading device into a receptacle on the outside of a building
  - Scanning probe picks up signal from meter, transmits readout to handheld device

## Meter Testing, Maintenance, and Repair



## Testing and Maintenance

- Water meters should be tested, at a minimum:
  - Before installation
  - After maintenance
  - At customer's request
- Testing new meters allows utilities to limit metering errors
- Over time, meter efficiency decreases
  - Fail to operate under low flows (under register)
- Each utility should establish a meter testing schedule
  - Small meters tested every 5-10 years
  - Large meters every 1-4 years



## Testing Procedure

- Three basic elements
  - Running a number of different flow rates
    - Positive displacement meters - maximum, intermediate, minimum
    - Current and compound meters – four or five flow rates run
  - Passing known quantities of water through meter at various flow rates
  - Meeting accuracy limits on different rates

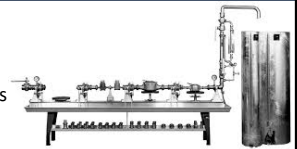

## Testing Procedures

- Testing meters in house
  - Test bench to hold meters
  - Inlet valve
  - Quick closing discharge valve
  - Rate of flow indicator (rotameter)
  - Calibrated tank or weighed tank
  - Ample supply of water
- Field testing large meters
  - Place meter to be tested and a previously calibrated meter in series
  - Compare flow results

## Maintenance and Repair

- When removing a meter, water should be sealed inside meter with plugs
  - Do not allow meter to get dry or any foreign material to get inside the meter
- Maintenance and repair for positive displacement meters involves the following general steps
  - Dismantle meter
  - Clean all parts
  - Inspect parts for damage
  - Replace or repair as necessary
  - Reassemble and retest

## Record Keeping

- Essential part of any distribution system
- Meter history card
  - Size
  - Make
  - Type
  - Date of purchase
  - Location
  - All tests and repair work

## Meter Change Out Procedures

1. Find out reason for change out
2. Notify customer that their water will be off for short time and ask them to cut it off at house
3. Get the tools that will be needed
4. Cut water off at curb stop
5. Remove meter
6. Spray new meter with chlorine
7. Put new meter in making sure arrow is facing house
8. Instruct customer to turn water on at house but not to draw any water
9. Cut water back on at curb stop
10. Turn outside faucet on and flush line
11. Take chlorine samples
12. Fill out meter job ticket and work order with:
  - ◆ New and old meter number
  - ◆ New and old reading
  - ◆ Chlorine reading
  - ◆ Crew and supplies used
  - ◆ Address and reason for change out

## **Water Services and Meters REVIEW QUESTIONS**

1. What is the function of a gooseneck in a service line?
  
2. What is the function of a curb stop?
  
3. Identify the two most popular materials used for residential water services.
  
4. Explain why lead and wrought iron are no longer used for residential services.
  
5. What is a possible problem when iron services are installed with bronze curb stops?
  
6. What two factors must water suppliers consider when determining the depth and location of a service line.
  
7. What are three reasons for metering water customers?
  
8. Identify three meters commonly used in the water distribution system.



9. Name and describe the operation of two major types of positive displacement meters.
  
10. What is the most common application for a small positive displacement meter?
  
11. Compound meters are generally used under what conditions?
  
12. What types of meters might be used for main line or pump station measurements?
  
13. What are the requirements for acceptable meter installations?
  
14. What is a meter yoke?
  
15. Explain the need for maintaining electrical continuity around the meter during removal.
  
16. When should water meters be tested?
  
17. List three basic elements in a meter test.

18. What hazards are associated with electrically thawing a frozen service line?

19. What items should be recorded on a service connection record card?

20. What items should be recorded on a meter history card?

## Answers

1. A flexible connection that provides for ease of installation and allows for any settlement of the overlying material, or expansion and contraction of the service line due to temperature variations.
2. A meter shut off located in the water service pipe near the curb between the water main and building in which the meter is located.
3. Copper and plastic
4. Lead joints are difficult to install properly and there is some question concerning safety (in terms of the water quality) or lead services. Wrought iron is rigid and requires threading, making it difficult to install. Wrought iron services may also have short lives due to corrosion.
5. Use of dissimilar materials often forms a galvanic cell and causes corrosion of the pipe.
6. Frost penetration and location of other utility lines.
7. Collecting revenues. Encourages customer to use water wisely. Provide indication of water demand.
8. 1. Positive displacement. 2. Compound. 3. Current.
9.
  - ◆ Piston-type meter, water flows into the chamber, which houses the piston. As it flows through the chamber, the piston is displaced. The motion of the piston is transmitted to the register, via magnets in newer models or gears in older models. This records the volume of water flowing through the meter.
  - ◆ The nutating disc meter uses a measuring chamber containing a hard rubber disc instead of a piston. When water flows through the chamber, the disc wobbles in proportion to the volume. This motion is transmitted to a register that records the volume of water flowing through the meter.
10. Metering residential services.
11. Where water demand varies considerably from high and low flows.
12. Propeller, venturi, proportional and turbine type meters might be used
13.
  - ◆ Not be subject to flooding with non-potable water.
  - ◆ Provide up and down stream shut-off valve of high quality to isolate the meter for repairs.
  - ◆ Position meter in horizontal plane for optimum performance.
  - ◆ Reasonably accessible for service and inspection.
  - ◆ Provide for easy reading.
  - ◆ Protected from frost and mechanical damage.
  - ◆ Not an obstacle or hazard to customer or public safety.
  - ◆ Meter is sealed to prevent tampering.
  - ◆ Proper support for large meters to avoid stress on pipe.
  - ◆ There be a by-pass or multiple meters on large installations.

14. A device that holds the stub ends of the pipe in proper alignment and spacing. It cushions the meter against stress and strain in the pipe and provides electrical continuity if metal pipe is used.
15. Reduces the chance of electrical shock during meter removal due to stray current or electrical grounding to the service pipe.
16. Meters should be tested before use, removal from service, after repairs, and upon customer complaint or request.  
Running different rates of flow to determine overall meter efficiency.
17. Passing known quantities of water through the meter at various test rates to provide a reasonable determination of meter registration. Meeting accuracy limits on different rates for acceptable use.
18. Damage to the service line, plumbing, and electrical appliances. Stray current can cause fire or electrical shock.
19. Permanent service number, applicant's name and address, dates of application and installation, size of corporation and curb stop used, size and type pipe used, depth of installation, and detailed measurements of locations.
20. Size, make, type, date of purchase, location, test data, and any repairs on the meter should be included on a meter history card.

**Section 9**  
**Cross Connection Control**



## Cross-Connection Control

## Outline

- Case studies of backflow incidents
- Basics of Cross-Connection Control
- Hydraulics
- Definitions
- Backflow Preventers
- Applications

### Backflow Case Study Human Blood in the Water System

- Blood observed in drinking fountains at a funeral home
- Hydraulic aspirator used to drain body fluids during embalming
- Contamination caused by low water pressure while aspirator was in use

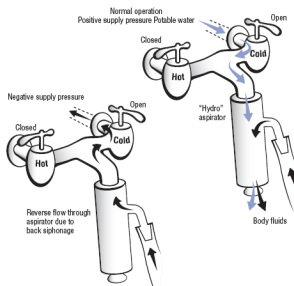

### Backflow Case Study Kool-Aid Laced with Chlordane

- Exterminator submerged garden hoses in small buckets while mixing insecticide at the same time a water meter was being installed nearby
- During a new water meter installation chlordane was back siphoned into water lines and became mixed with Kool-Aid
- A dozen children and three adults became sick

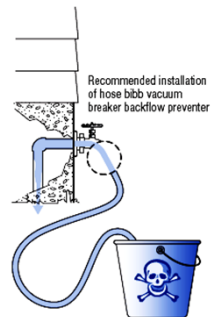

### Backflow Case Study Propane Gas in the Water Mains

- Gas company initiated repairs on 30,000 gallon liquid propane tank by flushing with fire hydrant
- Vapor pressure of propane residual in the tank exceeded water main pressure
- Hundreds evacuated, two homes caught fire, water supply contaminated

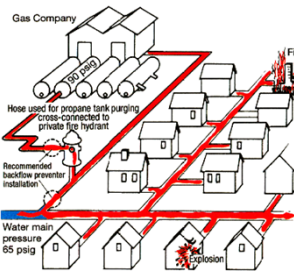

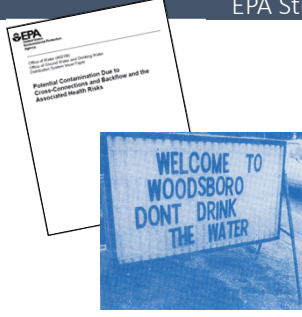

### Backflow Case Study EPA Study

- EPA compiled backflow incident data from 1970 to 2001 and found:
  - 459 incidents resulted in
  - 12,093 illnesses
  - Backflow incidents can result in property damage, personal injury, and even death



### Authority

- Federal
  - Federal Safe Drinking Water Act
- State
  - Tennessee Safe Drinking Water Act
  - Statute
  - Regulation
- Local
  - Ordinance (City) or Policy (Utility)
  - Plumbing Code
  - Cross Connection Control Plan





### Hydraulics and Pressure

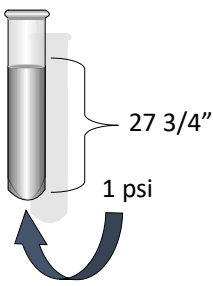

- Water can flow through a pipe in either direction
- The direction of flow will depend on the forces (pressures) acting on the water
- Water pressure naturally tends to equalize
- Therefore, water flows down a gradient from high pressure regions to low pressure regions

### Head Pressure



27 3/4" = 2.31 Feet of Head

- 27 3/4" of water generates a pressure of one pound per square inch (psi)
- The pressure on the bottom of the container is generated by the weight of the water above it



### Normal Flow

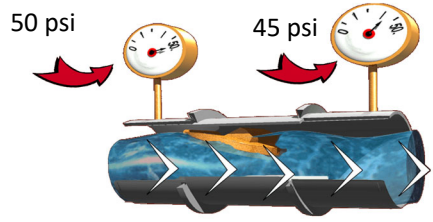

### No Flow

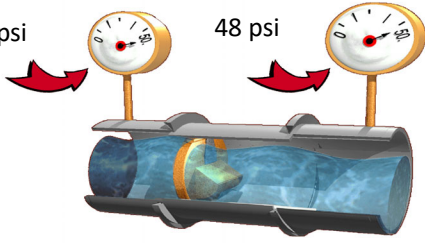

### Normal Flow

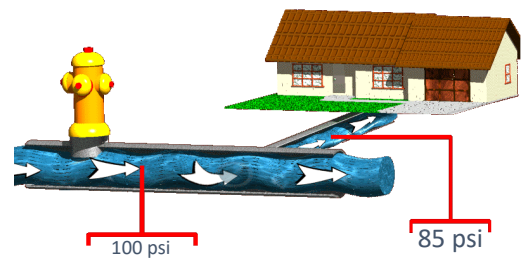

### Reverse Flow - Backflow

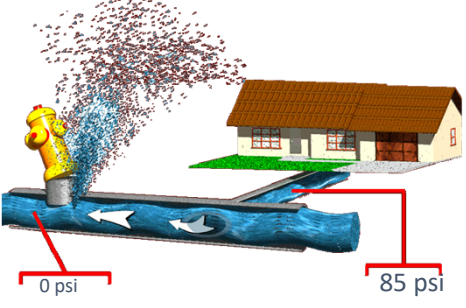

A diagram showing a pipe with a fire hydrant on the left and a house on the right. The fire hydrant is labeled '0 psi' and the house is labeled '85 psi'. White arrows indicate the normal flow direction from the house towards the hydrant. A large splash of water is shown erupting from the hydrant, indicating a reverse flow of water from the house back to the hydrant.

### Backflow

- The undesirable reversal of flow of water or other substances into the potable water distribution supply



- Occurs due to:
  - Backpressure
  - Backsiphonage

### Backpressure

- Pressure in downstream piping greater than supply pressure

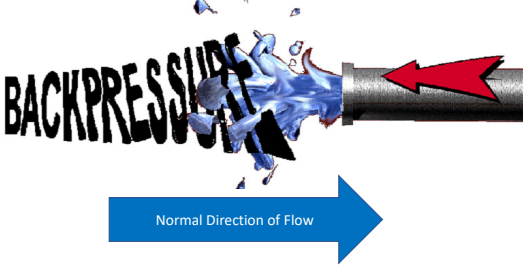

A diagram showing a pipe with a large splash of water erupting from the right side. A red arrow points to the left, indicating the direction of the backpressure. A blue arrow below the pipe points to the right, labeled 'Normal Direction of Flow'.

### Backpressure

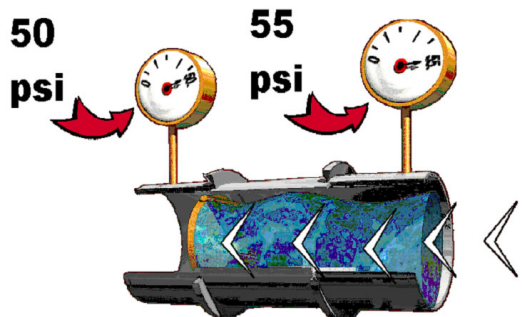

A diagram showing a pipe with two pressure gauges. The left gauge is labeled '50 psi' and the right gauge is labeled '55 psi'. Red arrows point from the gauges towards the pipe. A blue arrow below the pipe points to the right, labeled 'Normal Direction of Flow'.

### Backsiphonage

- Sub-atmospheric pressure in the water system

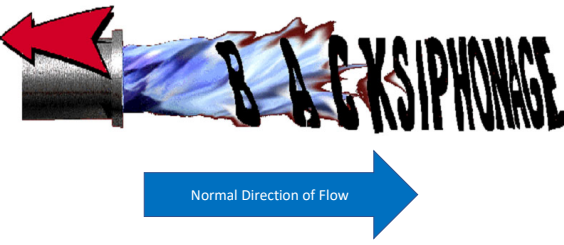

A diagram showing a pipe with a large splash of water erupting from the left side. A red arrow points to the left, indicating the direction of the backsiphonage. A blue arrow below the pipe points to the right, labeled 'Normal Direction of Flow'.

### Backsiphonage

*What is drawn into the water pipes if backsiphonage occurs?*



- As backsiphonage occurs air will be drawn up into the water pipes



### Backsiphonage

*What is drawn into the water pipes if backsiphonage occurs?*



➤ Whatever is in the barrel...



### Backsiphonage

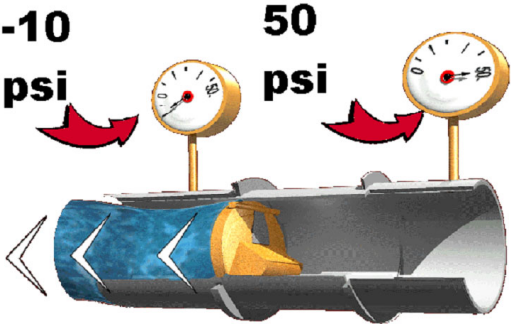

### Aspirator Effect



➤ As water flows through a pipe, the pressure against the walls of the pipe decreases as the speed of the water increases

➤ If a second pipe is attached there could be a low pressure area created at the point of connection which could siphon water from the attached pipe into the flowing pipe - Backsiphonage

### Cross-Connection

➤ An actual or potential connection between a potable water supply and any non-potable substance or source

➤ Cross-connection types:

- Direct
- Indirect



### Direct Cross-Connection

➤ A direct cross-connection is subject to backpressure or backsiphonage

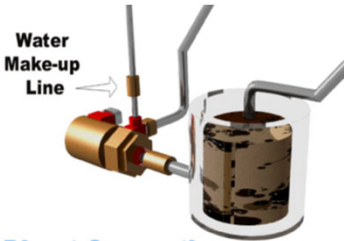

**Direct Connection**

### Indirect Cross-Connection

➤ An indirect cross-connection is subject to backsiphonage only

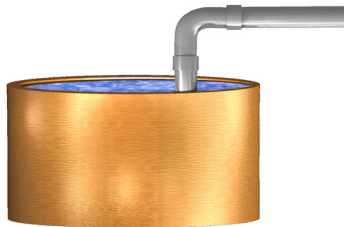

**Submerged Inlet**

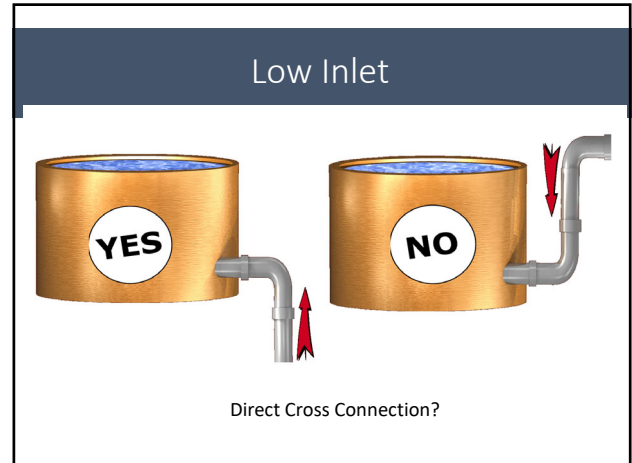
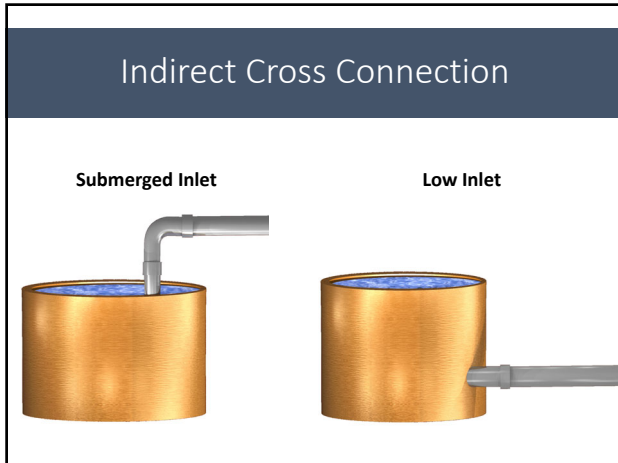

### Degree of Hazard

<ul style="list-style-type: none"> <li>➤ Non-Health Hazard                     <ul style="list-style-type: none"> <li>➤ Low hazard</li> <li>➤ Will not cause illness or death</li> <li>➤ Pollutant</li> </ul> </li> </ul>	<ul style="list-style-type: none"> <li>➤ Health Hazard                     <ul style="list-style-type: none"> <li>➤ High hazard</li> <li>➤ Causes illness or death</li> <li>➤ Contaminant</li> </ul> </li> </ul>
---------------------------------------------------------------------------------------------------------------------------------------------------------------------------------------------------------------------------	------------------------------------------------------------------------------------------------------------------------------------------------------------------------------------------------------------------



### The Backflow Incident

For backflow to occur three conditions must be met:

1. There must be a cross-connection. A passage must exist between the potable water system and another source.
2. A hazard must exist in this other source to which the potable water is connected.
3. The hydraulic condition of either backsiphonage or backpressure must occur.

### Five Means of Preventing Backflow

- Air Gap Separation (AG) Best Method
- Reduced Pressure Principle Assembly (RPZ/RPBP/RP) Best Device
- Double Check Valve Assembly (DCVA)
- Pressure Vacuum Breaker (PVB)/ Spill-Resistant Vacuum Breaker
- Atmospheric Vacuum Breaker (AVB)

### Air Gap



➤ An air gap is the vertical separation between the water supply line outlet and the overflow rim of the non-pressurized receiving fixture or tank

### Air Gap



2 X ID,  
not <1 inch

- An air gap is the *BEST* method of protection against backflow
- Approved air gap separation must have a vertical unobstructed distance of at least twice the internal diameter of the outlet pipe, but never less than 1 inch

### Air Gap Separation Limitations

- The air gap is the best method of backflow prevention, but it is easily defeated through modifications or being bypassed
- The air gap separation causes a loss of pressure in the system
- Sanitary control is lost - cannot be installed in an environment containing airborne contamination



### Approved Air Gap Separation

- Backflow Protection Against:
  - Backsiphonage
  - Backpressure
  - Contaminant (health hazard)
  - Pollutant (non-health hazard)



BEST METHOD OF PROTECTION

### Reduced Pressure Principle Assembly

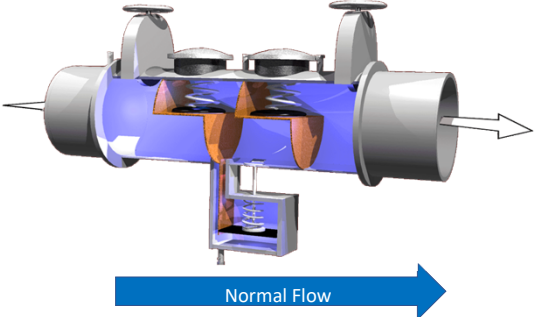

Normal Flow

### Reduced Pressure Principle Assembly

- The reduced pressure principle backflow prevention assembly (RP) consists of two independently operating check valves together with a hydraulically operating, mechanically independent, pressure differential relief valve located between the check valves, all located between two resilient seated shutoff valves and four properly located test cocks.
- *BEST* device to protect against backflow



### RP

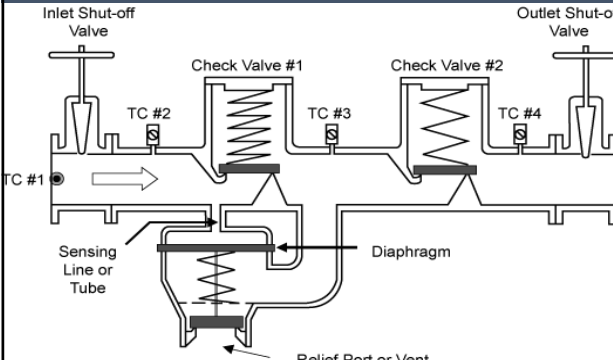

Relief Port or Vent

### RP

- The two check valves loaded in the closed position mechanically keep the water flowing in one direction through the assembly
- The relief valve assembly is designed to maintain a lower pressure in the zone between the two checks than in the supply side of the unit which hydraulically keeps the water flowing in one direction through the assembly
- Water always flows from high pressure to low pressure

### RP

- Backflow Protection Against:
- Backsiphonage
- Backpressure
- Contaminant (health hazard)
- Pollutant (non-health hazard)

BEST DEVICE FOR PROTECTION



### Double Check Valve Assembly (DC)

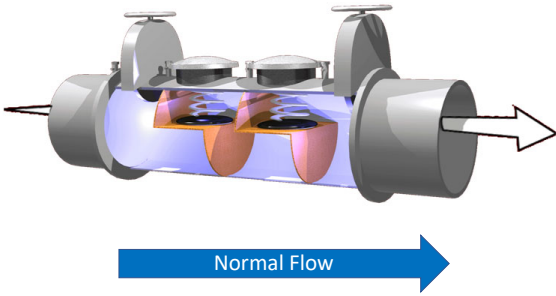

### Double Check Valve Assembly (DC)

- The double check valve backflow prevention assembly (DC) consists of two independently operating check valves installed between two tightly closing resilient seated shutoff valves and fitted with four properly located test cocks
- Similar to the RP, but has no relief port so it cannot maintain a lower pressure in the zone between the checks and nowhere for the water to go during a backflow incident or failure



### Double Check Valve Assembly (DC)

- Since the water in a DC cannot leave the system during a backflow event or assembly failure then it is a higher risk and therefore cannot be used in a high hazard (contaminant) application
- If one check fails the other will continue to protect, but given enough time the second check will fail and backflow will occur

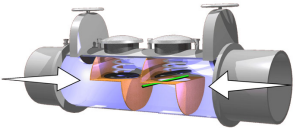

Second check fouled during backpressure

### Double Check Valve Assembly (DC)

- Backflow Protection Against:
- Backsiphonage
- Backpressure
- Pollutant only



### Proper Installation for DC and RP

- Lowest part of the relief valve should be a minimum of 12 inches above either: the ground, the top of the opening of the enclosure wall, or the maximum flood level
- Whichever is highest, in order to prevent any part of the assembly from becoming submerged
- Maximum 60" above grade to the center line of assembly, if higher then safe permanent access must be provided for testing and servicing

\* Tennessee Cross-Connection Control Manual and Design Criteria for Cross-Connection Control Plans, Ordinances, and Policies (2008) – Appendix B

### Proper Installation for DC and RP

- Assemblies should be installed in accordance with manufacturer's installations otherwise it voids the approval for the assembly
- Protected from vandalism and weather (if needed)
- RP requires adequate drainage – **cannot** be installed in a pit or meter box
- Must be accessible for testing and repair



### Pressure Vacuum Breaker (PVB)

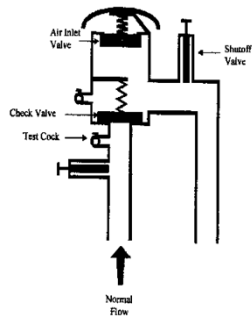

### Pressure Vacuum Breaker (PVB)

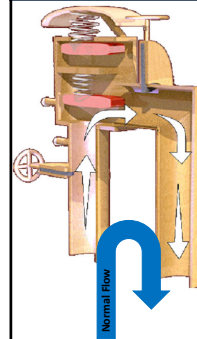

- The pressure vacuum breaker or spill resistant vacuum breaker consists of an independently operating check valve loaded in the closed position and an independently operating air inlet valve loaded in the open position and located on the discharge side of the check valve, with tightly closing shutoff valves on each side of the check valves, and properly located test cocks for valve testing

### Pressure Vacuum Breaker (PVB)

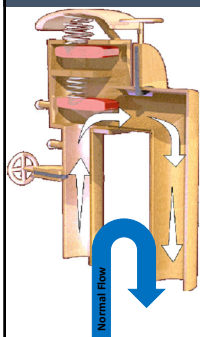

- Incoming water pressure will compress the spring on the check and flow into the body
- As pressure builds up in the body it will compress the spring on the air valve and close it allowing water to travel downstream

### PVB Backsiphonage Condition

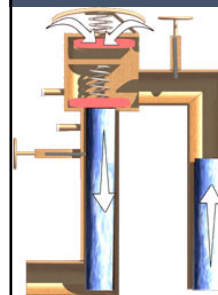

- In a backsiphonage condition there is a loss of supply pressure and the check valve is forced closed
- If the body loses pressure the air inlet valve is forced open allowing air into the body of the pressure vacuum breaker and breaking any siphon
- Only to be used to protect against backsiphonage

### Installation of PVB

- PVB is not designed to protect against backpressure and cannot have any source of backpressure (including head pressure) downstream of the device
- Needs to be installed **12 inches** above the highest point downstream

### Pressure Vacuum Breaker

- Acceptable installation not subject to backpressure

### Pressure Vacuum Breaker

- Improper installation subject to backpressure

Pump creating higher pressure than supply pressure = Backpressure

### Pressure Vacuum Breaker

- Backflow Protection Against:
- Backsiphonage Only
- Contaminant (health hazard)
- Pollutant (non-health hazard)
- Elevation - at least 12" above downstream piping

### Atmospheric Vacuum Breaker (AVB)

Atmospheric Vacuum Breaker Exploded View

### Atmospheric Vacuum Breaker (AVB)

- The atmospheric vacuum breaker is a device designed to prevent backsiphonage. It consists of a body, a single moving float that acts as a check valve when there is no flow and as an air-inlet valve when flow is present, and an air-inlet opening covered by a cap

### Atmospheric Vacuum Breaker (AVB)

- During a backsiphonage condition the float drops by gravity due to the loss of incoming pressure which automatically opens the air inlet, introducing air into the system to break any siphon that has formed

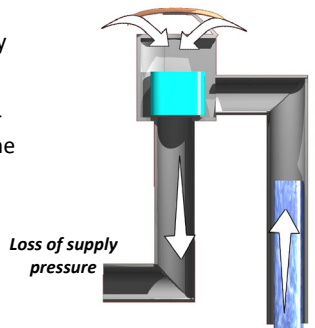

### Installation of AVB

- AVB is not designed to protect against backpressure and cannot have any source of backpressure (including head pressure) downstream of the device

- Needs to be installed **6 inches** above the highest point downstream

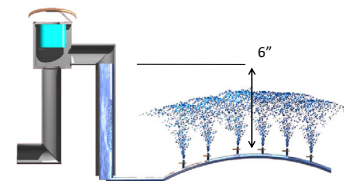

### Atmospheric Vacuum Breaker

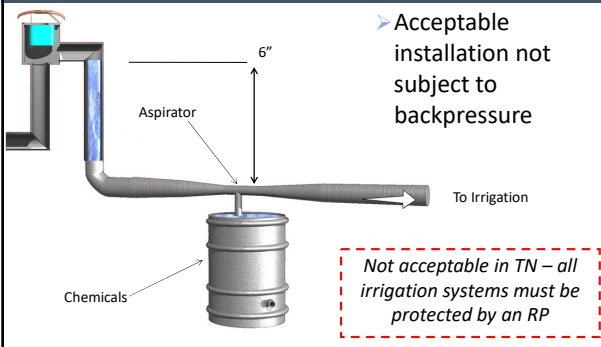

- Acceptable installation not subject to backpressure

### Atmospheric Vacuum Breaker

- Improper installation: downstream shutoff valves
- Shutoff valves downstream of an AVB can cause a continuous use situation
- The float of an AVB subjected to continuous use could begin to adhere to the air inlet and allow backflow

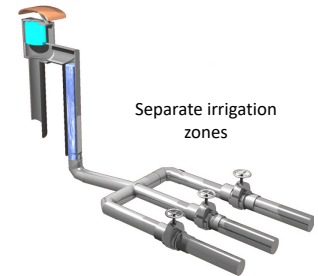

### Atmospheric Vacuum Breaker

- Backflow Protection Against:
- Backsiphonage Only
- Contaminant (health hazard)
- Pollutant (non-health hazard)
- Elevation - at least 6"
- Non-Continuous Use



	Indirect		Direct
	Backsiphonage Only		Backpressure and Backsiphonage
	Continuous Use	Non-Continuous Use	
Health Hazard	Air Gap	Air Gap	Air Gap
	RP	RP	RP
	PVB	PVB	
		AVB	
Non - Health Hazard	Air Gap	Air Gap	Air Gap
	RP	RP	RP
	DC	DC	DC
	PVB	PVB	
		AVB	

## Testing of Assemblies

- Assemblies must be tested when installed, after repair, and at least annually
- Assembly testing must be conducted by certified personnel
- TDEC issues a certification for all assembly testers
- Backflow tester certification courses are offered through the Fleming Training Center



## Cross Connection Control

*The ultimate goal of cross connection control is to protect the public drinking water supply*





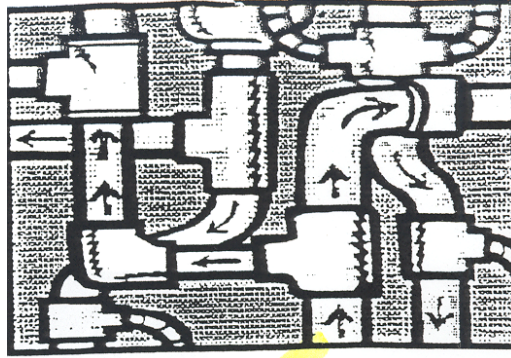

## Vocabulary

**Absolute Pressure** – The total pressure; gauge pressure plus atmospheric pressure. Absolute pressure is generally measured in pounds per square inch (psi).

**Air Gap** – The unobstructed vertical distance through the free atmosphere between the lowest opening from any pipe or outlet supplying water to a tank, plumbing fixture or other device, and the flood-level rim of the receptacle. This is the most effective method for preventing backflow.

**Atmospheric Pressure** – The pressure exerted by the weight of the atmosphere (14.7 psi at sea level). As the elevation above sea increases, the atmospheric pressure decreases.

**Backflow** – The reversed flow of contaminated water, other liquids or gases into the distribution system of a potable water supply.

**Backflow Prevention Device (Backflow Preventer)** – Any device, method or construction used to prevent the backward flow of liquids into a potable distribution system.

**Back Pressure (Superior Pressure)** – (1) A condition in which the pressure in a nonpotable system is greater than the pressure in the potable distribution system. Superior pressure will cause nonpotable liquids to flow into the distribution system through unprotected cross connections. (2) A condition in which a substance is forced into a water systems because that substance is under higher pressure than the system pressure.

**Backsiphonage** – (1) Reversed flow of liquid cause by a partial vacuum in the potable distribution system. (2) A condition in which backflow occurs because the pressure in the distribution system is less than atmospheric pressure.

**Bypass** – Any arrangement of pipes, plumbing or hoses designed to divert the flow around an installed device through which the flow normally passes.

Chemical – A substance obtained by a chemical process or used for producing a chemical reaction.

Containment (Policy) – To confine potential contamination within the facility where it arises by installing a backflow prevention device at the meter or curbstop.

Contamination – The introduction into water of any substance that degrades the quality of the water, making it unfit for its intended use.

Continuous Pressure – A condition in which upstream pressure is applied continuously (more than 12 hours) to a device or fixture. Continuous pressure can cause mechanical parts within a device to freeze.

Cross Connection – (1) Any arrangement of pipes, fittings or devices that connects a nonpotable system to a potable system. (2) Any physical arrangement whereby a public water system is connected, either directly or indirectly, with any other water supply system, sewer, drain, conduit, pool, storage reservoir, plumbing fixture or other waste or liquid of unknown or unsafe quality.

Cross Connection Control – The use of devices, methods and procedures to prevent contamination of a potable water supply through cross connections.

Degree of Hazard – The danger posed by a particular substance or set of circumstances. Generally, a low degree of hazard is one that does not affect health, but may be aesthetically objectionable. A high degree of hazard is one that could cause serious illness or death.

Direct Connection – Any arrangement of pipes, fixtures or devices connecting a potable water supply directly to a nonpotable source; for example, a boiler feed line.

Distribution System – All pipes, fitting and fixtures used to convey liquid from one point to another.

Double Check-Valve System Assembly – A device consisting of two check valves, test cocks and shutoff valves designed to prevent backflow.

Gauge Pressure – Pounds per square inch (psi) that are registered on a gauge. Gauge pressure measures only the amount of pressure above (or below) atmospheric pressure.

Indirect Connection – Any arrangement of pipes, fixtures or devices that indirectly connects a potable water supply to a nonpotable source; for example, submerged inlet to a tank.

Isolation (policy) – To confine a potential source of contamination to the nonpotable system being served; for example, to install a backflow prevention device on a laboratory faucet.

Liability – Obligated by law.

Negative Pressure – Pressure that is less than atmospheric; negative pressure in a pipe can induce a partial vacuum that can siphon nonpotable liquids into the potable distribution system.

Nonpotable – Any liquid that is not considered safe for human consumption.

Nontoxic – Not poisonous; a substance that will not cause illness or discomfort if consumed.

Physical Disconnection (Separation) – Removal of pipes, fittings or fixtures that connect a potable water supply to a nonpotable system or one of questionable quality.

Plumbing – Any arrangement of pipes, fittings, fixtures or other devices for the purpose of moving liquids from one point to another, generally within a single structure.

Poison – A substance that can kill, injure or impair a living organism.

Pollution – Contamination, generally with man-made waste.

Potable – Water (or other liquids) that are safe for human consumption.

Pressure – The weight (of air, water, etc.) exerted on a surface, generally expressed as pounds per square inch (psi).

Pressure Vacuum Breaker – A device consisting of one or two independently operating, spring-loaded check valves and an independently operating, spring-loaded air-inlet valve designed to prevent backsiphonage.

Reduced-Pressure-Principle or Reduced-Pressure-Zone Device (RP or RPZ) – A mechanical device consisting of two independently operating, spring-loaded check valves with a reduced pressure zone between the checks designed to protect against both backpressure and backsiphonage.

Refusal of Service (Shutoff Policy) – A formal policy adopted by a governing board to enable a utility to refuse or discontinue service where a known hazard exists and corrective measures are not undertaken.

Regulating Agency – Any local, state or federal authority given the power to issue rules or regulations having the force of law for the purpose of providing uniformity in details and procedures.

Relief Valve – A device designed to release air from a pipeline, or introduce air into a line if the internal pressure drops below atmospheric pressure.

Submerged Inlet – An arrangement of pipes, fittings or devices that introduces water into a nonpotable system below the flood-level rim of a receptacle.

Superior Pressure – See backpressure.

Test Cock – An appurtenance on a device or valve used for testing the device.

Toxic – Poisonous; a substance capable of causing injury or death.

Vacuum (Partial Vacuum) – A condition induced by negative (sub atmospheric) pressure that causes backsiphonage to occur.

Venturi Principle – As the velocity of water increases, the pressure decreases. The Venturi principle can induce a vacuum in a distribution system.

Waterborne Disease – Any disease that is capable of being transmitted through water.

Water Supplier (Purveyor) – An organization that is engaged in producing and/or distributing potable water for domestic use.

## Some Cross-Connections and Potential Hazards

<u>Connected System</u>	<u>Hazard Level</u>
Sewage pumps	High
Boilers	High
Cooling towers	High
Flush valve toilets	High
Garden hose (sil cocks)	Low to high
Auxiliary water supply	Low to high
Aspirators	High
Dishwashers	Moderate
Car wash	Moderate to high
Photographic developers	Moderate to high
Commercial food processors	Low to moderate
Sinks	High
Chlorinators	High
Solar energy systems	Low to high
Sterilizers	High
Sprinkler systems	High
Water systems	Low to high
Swimming pools	Moderate
Plating vats	High
Laboratory glassware or washing equipment	High
Pump primers	Moderate to high
Baptismal founts	Moderate
Access hole flush	High
Agricultural pesticide mixing tanks	High
Irrigation systems	Low to high
Watering troughs	Moderate
Autopsy tables	High

## Cross Connection Vocabulary

- |                                                                                                                                                                                                                                                       |                                                                                                                                                                                                                  |
|-------------------------------------------------------------------------------------------------------------------------------------------------------------------------------------------------------------------------------------------------------|------------------------------------------------------------------------------------------------------------------------------------------------------------------------------------------------------------------|
| <p>_____ 1. Air Gap</p> <p>_____ 2. Atmospheric Vacuum Breaker</p> <p>_____ 3. Auxiliary Supply</p> <p>_____ 4. Backflow</p> <p>_____ 5. Back Pressure</p> <p>_____ 6. Backsiphonage</p> <p>_____ 7. Check Valve</p> <p>_____ 8. Cross Connection</p> | <p>_____ 9. Feed Water</p> <p>_____ 10. Hose Bibb</p> <p>_____ 11. Overflow Rim</p> <p>_____ 12. Pressure Vacuum Breaker</p> <p>_____ 13. Reduced Pressure Zone<br/>Backflow Preventer</p> <p>_____ 14. RPBP</p> |
|-------------------------------------------------------------------------------------------------------------------------------------------------------------------------------------------------------------------------------------------------------|------------------------------------------------------------------------------------------------------------------------------------------------------------------------------------------------------------------|

- A. A valve designed to open in the direction of normal flow and close with the reversal of flow.
- B. A hydraulic condition, caused by a difference in pressures, in which non-potable water or other fluids flow into a potable water system.
- C. Reduced pressure backflow preventer.
- D. In plumbing, the unobstructed vertical distance through the free atmosphere between the lowest opening from any pipe or outlet supplying water to a tank, plumbing fixture or other container, and the overflow rim of that container.
- E. A backflow condition in which the pressure in the distribution system is less than atmospheric pressure.
- F. A faucet to which a hose may be attached.
- G. A mechanical device consisting of two independently operating, spring-loaded check valves with a reduced pressure zone between the check valves.
- H. Any water source or system, other than potable water supply, that may be available in the building or premises.
- I. Water that is added to a commercial or industrial system and subsequently used by the system, such as water that is fed to a boiler to produce steam.
- J. A device designed to prevent backsiphonage, consisting of one or two independently operating spring-loaded check valves and an independently operating spring –loaded air-inlet valve.
- K. A backflow condition in which a pump, elevated tank, boiler or other means results in a pressure greater than the supply pressure.
- L. Any arrangement of pipes, fittings, fixtures or devices that connects a nonpotable water system.
- M. The top edge of an open receptacle over which water will flow.
- N. A mechanical device consisting of a float check valve and an air-inlet port designed to prevent backsiphonage.

## Cross-Connections Review Questions

1. Define a cross-connection.
  
2. Explain what is meant by backsiphonage and backpressure.
  
3. List four situations that can cause negative pressure in a potable water supply.
  - 
  - 
  - 
  -
  
4. List six waterborne diseases that are known to have occurred as a result of cross-connections.
  - 
  - 
  - 
  - 
  - 
  -
  
5. What is the most reliable backflow-prevention method?
  
  
6. Is a single check valve position protection against backflow? Why or why not?
  
  
7. How often should a reduced-pressure-zone backflow preventer be tested?

8. In what position should an atmospheric vacuum breaker be installed relative to a shutoff valve? Why?
  
9. How does a vacuum breaker prevent backsiphonage?
  
10. List seven elements that are essential to implement and operate a cross-connection control program successfully?
  - 
  - 
  - 
  - 
  - 
  - 
  -

#### Vocabulary Answers:

1. D
2. N
3. H
4. B
5. K
6. E
7. A
8. L
9. I
10. F
11. M
12. J
13. G
14. C

#### Review Question Answers:

1. A cross-connection is any connection or structural arrangement between a potable water system and a nonpotable system through which backflow can occur.



2. Backsiphonage is a condition in which the pressure in the distribution system is less than atmospheric pressure. In more common terms, there is a partial vacuum on the potable system.  
Backpressure is a condition in which a substance is forced into a water system because that substance is under a higher pressure than system pressure.
3.
  - fire demand
  - a broken water main or exceptionally heavy water use at a lower elevation than the cross-connection
  - a booster pump used on a system
  - undersized piping
4.
  - typhoid fever
  - dysentery and gastroenteritis
  - salmonellosis
  - polio
  - hepatitis
  - brucellosis
5. The most reliable backflow prevention method is an air gap.
6. A single check valve is not considered positive protection against backflow. A check valve can easily be held partially open by debris, corrosion products or scale deposits.
7. Reduced-pressure-zone backflow preventers should be tested at least annually.
8. An atmospheric vacuum breaker must be installed downstream from the last shutoff valve. If it is placed where there will be continuing backpressure, the valve will be forced to remain open, even under backflow conditions.
9. When water stops flowing forward, a check valve drops, closing the water inlet and opening an atmospheric vent. This lets water in the breaker body drain out, breaking the partial vacuum in that part of the system.
10.
  - an adequate cross-connection control ordinance
  - an adequate organization with authority
  - a systematic surveillance program
  - follow-up procedures for compliance
  - provisions for backflow-prevention device approvals, inspection and maintenance
  - public awareness and information programs



**Section 10**  
**Safety & Trenching**



## Safety

## Objectives

- General Duty Clause
- Traffic Safety
- Confined Spaces
- Lockout/Tagout
- Electrical Safety
- Fire Protection
- Chemical Safety

## Safety

- An accident is caused by either an unsafe act or an unsafe environment.
- Personal cleanliness is the best means of protection against infection

## General Duty Clause

- FEDERAL - 29 CFR 1903.1
- Worker Right to Know:
  - EMPLOYERS MUST: Furnish a place of employment free of recognized hazards that are causing or are likely to cause death or serious physical harm to employees. Employers must comply with occupational safety and health standards promulgated under the Williams-Steiger Occupational Safety and Health Act of 1970

## Before Leaving the Yard

- Work assignments
- Equipment needs
- Equipment inspection
- Vehicle inspection
  - When backing up a truck, one person should always be at the rear of the truck in view of the driver
  - Mirrors and windows
  - Lights and horn
  - Brakes
  - Tires
  - Trailer hitch/safety chain







## Traffic Safety

## Traffic Control Zones

- Advanced warning area
- Transition area
- Buffer space
- Work area
- Termination area

## Traffic Control Zones

**Advanced warning area length:**  
**Urban areas- 1 block**  
**Roadways- 1500 ft**  
**Freeways- ½ to 1 mile**

## Advanced Warning Area

- This is where you communicate to the motorists that traffic is changing ahead
  - This area will hopefully put the drivers on alert
- Must be long enough to give motorists adequate time to respond to particular work area conditions

## Advanced Warning Area

- Typically ½ mile to one mile for highways
- 1500 feet for most other types of roads
- At least one block for urban streets

## Transition Area

- Traffic is channeled from the normal highway lanes to the path required to move traffic around the work area
- Use of tapers
  - Channeling devices or pavement markings placed at an angle to direct traffic
- Not required if no lane or shoulder closure is involved

## Transition Area

- Types of tapers used in traffic control zones:
  - Lane closure tapers – To slowly angle traffic out of a lane and eventually close it off to motorists
  - Two-way traffic tapers – To control two-way traffic where traffic is required to alternately use a single lane (One Lane Two-Way Closure or Flagger Closure)
  - Shoulder closure taper – to close off shoulder areas from motorists
  - Downstream taper – Installed after the work area to return/direct traffic back into its normal path

### Buffer Space

- The buffer space is the open, unoccupied space between the transition and work areas
- Provides margin of safety for both the motorists and the operators in the street
- If a driver does not see the advanced warning signs or fails to negotiate the transition, a buffer space provides room to stop before entering the work area
- Must be kept free of equipment, operators, materials, and vehicles

### Work Area

- The portion of the roadway which contains the work activity and is closed to traffic and set aside for exclusive use by operators, equipment, and construction materials
- Delineated by channelizing devices or shielded by barriers to exclude traffic and pedestrians
- Include a lateral buffer space between work activity and traffic if possible



### Work Area

- All work must be done within the safety of the work area – no operator should work outside of the work area, including the buffer space
- Avoid gaps in the traffic control that may falsely lead drivers to think they have passed through the work area
- Post **Road Construction Next X Miles** to inform drivers of the length of work area
  - Do Not set up sign until work begins

### Termination Area

- Provides short distance for traffic to clear work area and return to normal traffic lanes
- Downstream tapers are optional and may not be advisable when material trucks move into the work area by backing up from the downstream end of the work area
- End of Road Work sign can be used to clearly communicate to the motorists



### Traffic Signs

- Always use official signs
- Most permanent warning signs are diamond-shaped with black legends on yellow background
- Temporary signs have an orange background
- Best to use picture direction instead of wording



### Traffic Signs

- Signs should be 36 inches by 36 inches for low-speed applications and 48 inches by 48 inches for high-speed applications
- Minimum mounting height on fixed supports should be seven feet from the ground to the bottom of the sign in urban districts and five feet in rural
- Signs mounted on barricades or temporary supports may be installed lower but the bottom of the sign should not be less than one foot above the pavement elevation



### Traffic Signs

- All traffic control devices should be constructed to yield upon impact to minimize damage to a vehicle that strikes them and to minimize hazards to motorists and workers
- No traffic control devices should be weighted so heavily that it becomes hazardous to motorists and operators
- Approved ballast for devices is sandbags, but should never be suspended from the device



### Channelizing Devices

- Used to warn drivers and alert them to conditions created by work activities in roadway, to protect workers in the traffic control, and to guide drivers and pedestrians
- Include barricades, traffic cones and tubes, drums, and vertical panels
- Devices are not interchangeable because they have different effects on traffic
- Devices must be in acceptable condition



### Channelizing Devices

- Barricades are commonly used to outline excavation or construction areas, close or restrict the right-of-way, mark hazards, or mount signs
- Have alternating orange and white stripes marked with reflectors that slope down toward traffic
- Classified as Type I, II, or III by the number of marked panels
- Type I and II are used in areas that traffic continues to move through, Type III are used to partially or completely close a roadway



### Channelizing Devices

- Traffic cones and tubes are an effective method of channelizing traffic and best when used during daylight hours
- Can be easily moved by passing vehicles so must be monitored
- Cones are 18-36 inches high and orange in color
- Drums have higher visibility and can have the addition of lights
- Drums are 2 orange and 2 white stripes



### Nighttime Traffic Control

- Additional modification to traffic control should be made for use at night
- Increased visibility of devices can be accomplished by use of lights on devices, use of larger devices such as drums, floodlighting for all flagging stations and work areas
- All traffic control devices used at night should have adequate retroreflective areas for high visibility
- All workers must have high visibility clothing approved for use at night – ANSI 107-2004 Class 3

### Flaggers – MUTCD Sec. 6E.01

***Because flaggers are responsible for public safety and make the greatest number of contacts with the public of all highway workers, they should be trained in safe traffic control practices and public contact techniques***



## Flaggers – MUTCD Sec. 6E.01

Flaggers should be able to satisfactorily demonstrate the following abilities:

- A. Ability to receive and communicate specific instructions clearly, firmly, and courteously
- B. Ability to move and maneuver quickly in order to avoid danger from errant vehicles
- C. Ability to control signaling devices (such as paddles and flags) in order to provide clear and positive guidance to drivers approaching a TTC zone in frequently changing situations
- D. Ability to understand and apply safe traffic control practices, sometimes in stressful or emergency situations
- E. Ability to recognize dangerous traffic situations and warn workers in sufficient time to avoid injury

## Flaggers

- Flaggers shall wear high visibility safety apparel that meets the Class 2 or 3 requirements of the ANSI/ISEA 107-2004
- Apparel background color shall be fluorescent orange-red, fluorescent yellow-green, or a combination of the two
- The retroreflective material shall be orange, yellow, white, silver, yellow-green and shall be visible at a minimum distance of 1000 feet



## Flaggers

- The STOP/SLOW paddle should be the primary and preferred hand-signaling device, use of flags should be limited to emergency situations
- Paddle shall have an octagonal shape on a rigid handle, be at least 18 inches wide with letters at least 6 inches high
- Flagging station should be at least 100 feet in front of the workspace with a sign indicating that a flagger is ahead positioned as far in front of the flagger as practical – 500 feet minimum



## Flaggers

- Flaggers should:
  - Stand either on the shoulder adjacent to the road or in the closed lane adjacent to the through lane
  - Never stand in a through lane unless traffic has already been stopped
  - Be clearly visible to oncoming traffic at all times
  - Be positioned far enough in advance to warn workers of approaching danger
  - Have a line of sight to other flagger or a way to communicate with the other flagger
  - Stand alone, away from others with no distractions (including cell phones!)



## Flaggers

- Flaggers must use proper hand signals to stop, slow, and allow traffic through the traffic closure
- Flagger should identify an escape route to avoid be struck by an errant vehicle

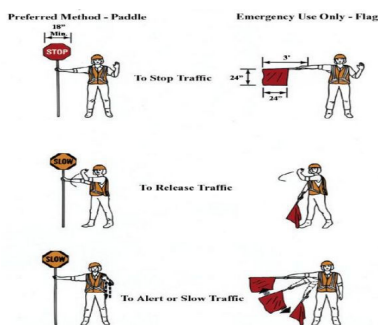

## Flaggers

### **REMEMBER**

**Flaggers are responsible for employee and public safety, they must have a sense of responsibility and they must receive appropriate training in traffic control practices**









## Confined Space

## Manhole Hazards

- Atmospheric
- Physical injury
- Infection and disease
- Insects and biting animals
- Toxic exposure
- Drowning

## Confined Space Conditions

- Large enough and so configured that an employee can bodily enter and perform assigned work
- Limited or restricted means of entry or exit
- Not designed for continuous employee occupancy

## Confined Space Examples

- Water storage tanks
- Chemical hoppers
- Meter Vaults
- Sewers
- Manholes



## Equipment Needed for Confined Spaces

- Safety harness with lifeline, tripod and winch
- Electrochemical sensors
- Ventilation blower with hose
  - Should have a capacity of no less than 750-850 cfm





## Equipment Needed for Confined Spaces

- PPE
- Ladder
- Rope
- Breathing Apparatus





### Permit Required Confined Space

- Contains or has potential to contain hazardous atmosphere
- Contains material with potential to engulf an entrant
- Entrant could be trapped or asphyxiated
- Positions required for entrance into a permit required confined space
  - Supervisor
  - Attendant – at least one person must be outside a permit required space
  - Entrant

### Atmospheric Hazards

- Need to have atmosphere monitored!!!
  - Depletion or elimination of breathable oxygen
    - Oxygen deficient atmosphere
    - Minimum oxygen level is 19.5%
  - Explosive or flammable gas or vapor
    - These can develop in the collection system or sewer plant due to legal, illegal or accidental sources
  - Toxic or suffocating gases
    - Comes from natural breakdown of organic matter in wastewater or toxic discharges

### Atmospheric Hazards

ATMOSPHERIC TESTING EQUIPMENT - ALARM SET @ 10% LEL

THREE ATMOSPHERIC CONDITIONS CAN EXIST

1. TOO LEAN TO SUPPORT COMBUSTION
2. MIXTURE JUST RIGHT, EXPLOSION OCCURS
3. MIXTURE TOO RICH TO SUPPORT COMBUSTION

\* Water Distribution System Operation and Maintenance, Seventh Edition – Fig. 6.2, Pg 395

### Hydrogen Sulfide – H<sub>2</sub>S

- Detected by the smell of rotten eggs
- Loss of ability to detect short exposures
  - Olfactory fatigue
- Not noticeable at high concentrations
- Poisonous, colorless, flammable, explosive and corrosive
- Exposures to 0.07% to 0.1% will cause acute poisoning and paralyze the respiratory center of the body
- At the above levels, death and/or rapid loss of consciousness occur
- S.G. = 1.19
- Alarm set point = 10 ppm (0.001%)

### Hydrogen Sulfide – H<sub>2</sub>S

%	PPM	Hazard
46	460,000	Upper Explosive Limit (UEL)
4.3	43,000	Lower Explosive (LEL)
0.1	1,000	DEAD
0.07	700	Rapid loss of consciousness
0.01	100	IDLH
0.005	50	Eye tissue damage
0.002	20	Eye, nose irritant
0.001	10	Alarm set point

\*IDLH - Immediately Dangerous to Life or Health

### Methane Gas – CH<sub>4</sub>

- Product of anaerobic waste decomposition
- Leaks in natural gas pipelines
  - Odorless unless natural gas supplied through pipeline, has mercaptans added, but soil can strip the odor
- Explosive at a concentration of 5% or 50,000 ppm
- Spaces may contain concentrations above the Lower Explosive Limits (LEL) and still have oxygen above the 19.5% allowable
- Colorless, odorless, tasteless
- Acts as an asphyxiant – displaces oxygen
  - Coal miners used canaries as early alarms; if bird died, it was time to get out
- S.G. = 0.55
- Alarm set point is 10% LEL = 5000 ppm

### Methane Gas – CH<sub>4</sub>

%	PPM	Hazard
85	850,000	Amount in natural gas
65	650,000	Amount in digester gas
15	150,000	Upper Explosive Limit (UEL)
5	50,000	Lower Explosive Limit (LEL)
0.5	5,000	Alarm set point (10% of LEL)

### Carbon Monoxide - CO

- Decreases amount oxygen present
  - Hazardous because it readily binds with hemoglobin in blood, starving the person's body of oxygen
- ALWAYS VENTILATE
- 0.15% (1500 ppm) DEAD
- Will cause headaches at 0.02% in two hour period
- Maximum amount that can be tolerated is 0.04% in 60 minute period
- Colorless, odorless, tasteless, flammable and poisonous
- By-product of fuel gas
  - Can be hazard in home if using gas heat or gas appliances
- S. G. = 0.97
- Alarm set point at 35 ppm

### Carbon Monoxide - CO

%	PPM	Hazard
74	740,000	Upper Explosive Limit (UEL)
12.5	125,000	Lower Explosive (LEL)
0.2	2,000	Unconscious in 30 minutes
0.15	1,500	IDLH*
0.05	500	Sever headache
0.02	200	Headache after 2-3 hours
0.0035	35	8-hour exposure limit
0.0035	35	Alarm set point

\*IDLH – Immediately Dangerous to Life or Health

### Oxygen – O<sub>2</sub>

- ALWAYS ventilate – normal air contains ~ 21%
- Oxygen deficient atmosphere if less than **19.5%**
- Oxygen enriched at greater than **23.5%**
  - Speeds combustion
  - Could be from pure oxygen being used to oxidize hydrogen sulfide
- Leave area if oxygen concentrations approach 22%
- Early warning signs that an operator is not getting enough oxygen:
  - Shortness of breath
  - Chest heaving
  - Change from usual responses

### Oxygen – O<sub>2</sub>

%	PPM	Hazard
23.5	235,000	Accelerates combustion
20.9	209,000	Oxygen content of normal air
19.5	195,000	Minimum permissible level
8	8,000	<b>DEAD</b> in 6 minutes
6	6,000	Coma in 40 seconds, then <b>DEAD</b>

### Oxygen – O<sub>2</sub>

- When O<sub>2</sub> levels drop below 16%, a person experiences
  - Rapid fatigue
  - Inability to think clearly
  - Poor coordination
  - Difficulty breathing
  - Ringing in the ears
  - Also, a false sense of well-being may develop

## Oxygen – O<sub>2</sub>

- In a confined space, the amount of oxygen in the atmosphere may be reduced by several factors
  - Oxygen consumption
    - During combustion of flammable substances
    - Welding, heating, cutting or even rust formation
  - Oxygen displacement
    - Carbon dioxide can displace oxygen
  - Bacterial action

## Atmospheric Alarm Units

- Continuously sample the atmosphere
- Test atmospheres from manhole areas prior to removing the cover if pick holes available
- Remove manhole covers with non sparking tools
- **Test for oxygen first**
- **Combustible gases second (methane at 5000 ppm)**
  - Atmospheric alarms with a catalytic element are used to test for explosive conditions.



## Atmospheric Alarm Units

- Alarms set to read:
  - Flammable gases exceeding 10% of the LEL
  - H<sub>2</sub>S exceeds 10 ppm and/or
  - O<sub>2</sub> percentage drops below 19.5%
  - CO alarm set point is 35 ppm
- Calibrate unit before using
- Most desirable units: simultaneously sample, analyze and alarm all three atmospheric conditions

## Atmospheric Alarm Units

- Some physical and environmental conditions that could affect the accuracy of gas detection instruments include:
  - Caustic gases
  - Temperature
  - Dirty air
  - Humidity
  - Air velocity
  - Vibration

## Safety Procedures if Explosive Atmosphere Discovered

- Immediately notify supervisor
- Do not remove manhole cover
- Turn off running engines in area
- Route vehicles around area
- Inspect up and downstream of manhole
- Route traffic off the street
- Notify waste and or pretreatment facility
- Cautiously ventilate
- **NO SMOKING IN AREA**



## August 13<sup>th</sup>, 2014 Nashville, TN



### Ventilation

- Blowers need to be placed upwind of manhole and at least 10 feet from opening
- Gas driven engine – exhaust must be downwind of manhole
- Air intake should be 2-5 feet above ground service



### Infectious Disease Hazards

- Many diseases may be transmitted by wastewater: hepatitis A, cholera, bacterial dysentery, polio, typhoid, amoebic dysentery
- Ingestion (splashes); inhalation (aerosols); contact (cuts or burns)
- Wash hands frequently
- Avoid touching face
- Never eat, drink or smoke without first washing hands



*Best method of protection is personal cleanliness!*

### Written Entry System

- Employer shall document entry permits
- Entry supervisor sign permits
- Permit posted
- Shall not exceed time required
- Retain permits for at least 1 year

### Information on Permit Forms

- |                                       |                                                          |
|---------------------------------------|----------------------------------------------------------|
| ➤ Space to be entered                 | ➤ Hazards of permit space                                |
| ➤ Purpose                             | ➤ Measures to eliminate, isolate, or control the hazards |
| ➤ Date and authorized duration        | ➤ Results of tests                                       |
| ➤ Attendant ID by name                | ➤ Rescue and emergency services                          |
| ➤ Authorized entrants ID by name      | ➤ Communications                                         |
| ➤ Entry supervisor name and signature |                                                          |

### Information on Equipment

- PPE (personal protective equipment)
- Testing equipment

### Duties Of Entrants

- Know signs, symptoms, and consequence of exposure
- Properly use equipment
- Alert attendant of warning signs, symptoms and other possible hazards
- Exit when ordered to evacuate by supervisor or attendant

### Duties of Confined Space Attendant

- Know signs, symptoms, and consequences of exposure
- Possible behavioral effects of hazards
- Maintain accurate count of entrants
- Remain outside permit space
- Communicate with entrants
- Summon rescue and emergency units

### Duties of Confined Space Attendant

- Warn unauthorized persons to stay away
- Perform non-entry rescue
- Do not perform any duties that may interfere with primary duty: monitoring and protecting entrants

### Duties of Supervisors and Managers

- Knowledge of signs, symptoms, and consequences of exposure
- Verify appropriate entries, procedure, tests and equipment
- Terminate entries and cancel permits if warranted
- Verify means for summoning rescue
- Ensure that acceptable conditions are maintained and operations remain consistent with entry permit

### Required Training

- Employer shall train all employees on hazards, procedures, and skills to perform their jobs safely
- Employees trained before first assigned duty
- Employer shall certify training of employees
- Maintain individual training records of employees

### Record Keeping

- Identification and Evaluation of all Hazardous areas in workplace
- Entrance permits filed
- Training Certification
- Written Confined Space Program

### General Requirements

- Identify, evaluate, and monitor hazards in permit-required confined spaces
- Post signs "Permit Required"
- Prevent unauthorized entries
- Re-evaluate areas
- Inform contractors
- Have a written program available for employees
- Have proper PPE on hand
- Annual Training (TOSHA requirements)

## Confined Space Requirements

- All electrodes removed and machines disconnected from power sources
- Gas supply shut off
- Gas cylinders outside work area
- All employees entering must undergo confined space training
- Ventilation used to keep toxic fumes, gases, and dusts below max levels

## Lockout / Tagout



## LOTO General Requirements

- Written program
- Utilize tagout system if energy isolating device not capable of being locked out
- Lockout/tagout hardware provided
- Devices used only for intended purposes
- Tagout shall warn **DO NOT START, DO NOT ENERGIZE, DO NOT OPERATE**
- Only trained employees shall perform lockout/tagout

## Requirements When Lockout of Equipment

- Before beginning work on any pump, the first thing to be done is to lock it out.
  - The person doing the work should have the **ONLY** key
- Notify employees
- Employees notified after completion of work and equipment re-energized



## Recommend Steps for Lockout/Tagout

- Notify employees that device locked and tagged out
- Turn off machine normally
- De-activate energy
- Use appropriate lockout/tagout equipment
- Release any stored energy
- Try to start machine by normal means

## Steps for Restoring Equipment

- Check area for equipment or tools
- Notify all employees in the area
- Verify controls are in neutral
- Remove lockout/tagout devices and re-energize device
- Notify employees maintenance and/or repairs are complete and equipment is operationally

### Training Requirements

- Employer shall train all employees
- All new employees trained
- Recognition of applicable hazardous energy
- Purpose of program
- Procedures
- Consequences
- ANNUAL REQUIREMENT

### Inspections

- Conduct periodic inspection at least annually
- Shall include review between the inspector and each authorized employee
- Recommendation: Frequent walk through of work areas and observation of Maintenance and Operation area

### Required Record Keeping

- Written Lockout/Tagout Program
- Training: Annual and New Employees
- Inspections: Annual including new equipment, inspection of devices, and procedures

### Most Frequently Cited Workplace Safety Violations 2015

- Fall protection (1926.501)
- Hazard communication (1910.1200)
- Scaffolding (1926.451)
- Respiratory protection (1910.134)
- Lockout/tagout (1910.14)
- Powered industrial trucks (1910.178)
- Ladders (1926.1053)
- Electrical – wiring methods (1910.305)
- Machine guarding (1910.212)

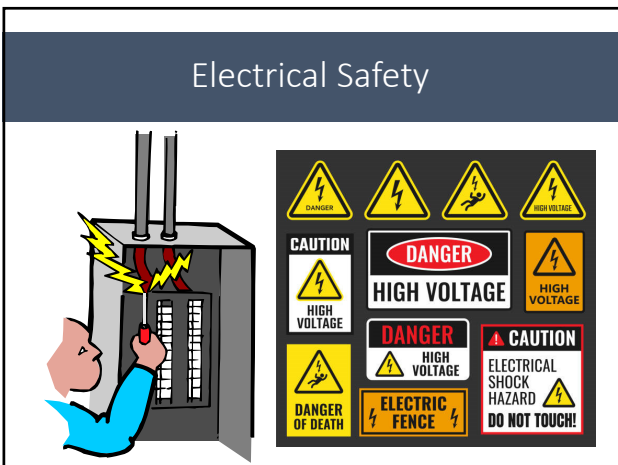
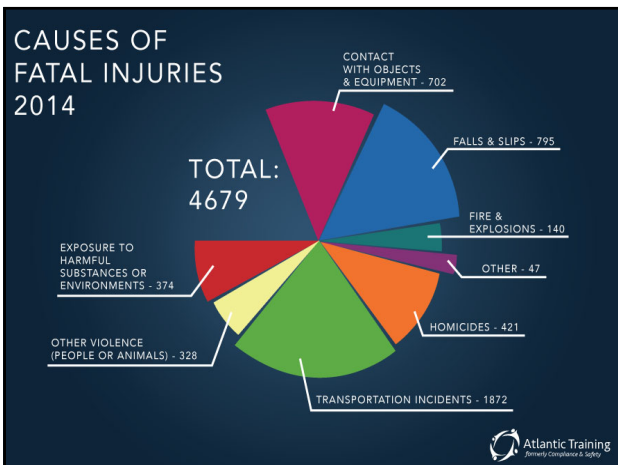



### OSHA Says

- Any electrical installations shall be done by a professionally trained electrician.
- Any employee who is in a work area where there is a danger of electric shock shall be trained.
- Employees working on electrical machinery shall be trained in lockout/tagout procedures



### Fire Protection



### Fire Protection Equipment

- Fire extinguishers shall be located where they are readily accessible
- Shall be fully charged and operable at all times
  - Charged after each use
- All fire fighting equipment is to be inspected at least annually
- Portable fire extinguishers inspected at least monthly, and records kept
- Hydrostatic testing on each extinguisher every five years
- Fire detection systems tested monthly if battery operated

### Types of Fire Extinguishers

- Class A 
  - Used on combustible materials such as wood, paper or trash
  - Can be water based
- Class B 
  - Used in areas where there is a presence of a flammable or combustible liquid
  - Shall not be water based
  - Example is dry chemical extinguisher
  - An existing system can be used but not refilled

### Types of Fire Extinguishers

- Class C 
  - Use for areas electrical
  - Best is carbon dioxide extinguisher
  - Using water to extinguish a class C fire risks electrical shock
- Class D
  - Used in areas with combustible metal hazards
  - Dry powder type
  - Use no other type for this fire

### Types of Fire Extinguishers

Class	Material	Method
A	Wood, paper	Water
B	Flammable liquids (oil, grease, paint)	Carbon dioxide, foam, dry chemical or Halon
C	Live electricity	Carbon dioxide, dry chemical, Halon
D	Metals	Dry Powder

## Types of Fire Extinguishers

- Combination ABC are most common
- Have the types of extinguishers available depending upon analyses performed in each area



**A**

Common materials such as paper, wood or most other combustibles



**B**

Flammable liquids such as gasoline, paint remover or grease



**C**

Electrical fires



**D**

Combustible metals usually found in industry



## Fire Extinguishers

- To operate a fire extinguisher, remember the word PASS
  - **P**ull the pin. Hold the extinguisher with the nozzle pointing away from you
  - **A**im low. Point the extinguisher at the base of the fire
  - **S**queeze the lever slowly and evenly
  - **S**weep the nozzle from side-to-side

## Fire Extinguishers



Combo Extinguisher

1. Pull pin. Hold unit upright. 
2. Aim at base of fire. Stand back 6ft (2m). 
3. Press trigger. Sweep side to side. 

## Chemical Safety



**HAZARDOUS MATERIALS CLASSIFICATION**

**HEALTH HAZARD**  
4-Doubtful  
3-Extreme danger  
2-Hazardous  
1-Slightly hazardous  
0-Normal material

**FIRE HAZARD Flash Points**  
4-Below 73°F  
3-Below 100°F  
2-Below 200°F  
1-Above 200°F  
0-Will not burn

**SPECIFIC HAZARD**  
Oxidizer OX  
Acid ACID  
Alkali ALK  
Corrosive COR  
Use NO WATER W  
Radiation Hazard

**INSTABILITY**  
4-May detonate  
3-Shock and heat may detonate  
2-Violent chemical change  
1-Unstable if heated  
0-Stable



**Safety Data Sheet**

## OSHA's Hazard Communication Standard (HCS)

- OSHA's Hazard Communication Standard (HCS) is designed to protect against chemical-source injuries and illnesses by ensuring that employers and workers are provided with sufficient information to anticipate, recognize, evaluate, and control chemical hazards and take appropriate protective measures
  - "Right-to-Know" standard
- This information is provided through safety data sheets (SDSs), labels, and employee training

## RTK Labels



➤ "Right to Know"

- In 1983, OSHA instituted Hazard Communication Standard 1910-1200, a rule that gives employees the right to know the hazards of chemicals to which they may be exposed in the workplace

## HCS Labels

- Purpose:
  - Informs workers about the hazards of chemicals in workplace under normal conditions of use and foreseeable emergencies
- Number System:
  - 1-4
  - 1 – most severe hazard ; 4 – least severe hazard
- Information provided on label:

Product Identifier	Precautionary Statement
Signal Word	Pictogram
Hazard Statement	Contact information

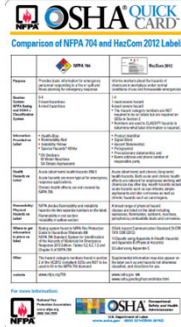

## National Fire Protection Association (NFPA) 704 Label

- Purpose:
  - Addresses the health, flammability, instability, and special hazards presented from short-term, acute exposures that could occur as a result of a emergency
- Number rating system:
  - 0-4; 0 – least hazardous; 4 – most hazardous
- Information provided on label:

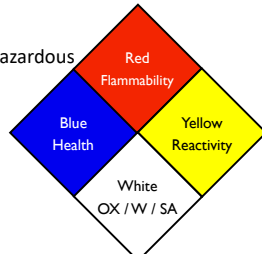

- Health
- Flammability
- Reactivity
- Special Hazards
  - OX → oxidizer
  - W → use NO WATER
  - SA → simple asphyxiant

## NFPA vs HCS Degree of Hazard

- NFPA rating system
  - 4 → extreme
  - 0 → minimal
- GHS rating system
  - 1 → highest hazard
  - 4 → lowest hazard

## Safety Data Sheet (SDS)

- Must be provided by chemical manufacturer, distributor, or importer
- Formerly known as MSDS
  - Now has consistent user-friendly format
- Sections 1-8 contain general information about the chemical
- Sections 9-11 & 16 contain other technical & scientific information
- Sections 12-15 are not enforced by OSHA, but must be present to be in compliance with GHS

## Safety Data Sheet Required Format

<ol style="list-style-type: none"> <li>1. Product identification</li> <li>2. Hazard Identification</li> <li>3. Information on ingredients</li> <li>4. First-aid measures</li> <li>5. Fire-fighting measures</li> <li>6. Accidental release measures</li> <li>7. Handling and storage</li> <li>8. Exposure controls</li> </ol>	<ol style="list-style-type: none"> <li>9. Physical/chemical properties</li> <li>10. Stability &amp; reactivity</li> <li>11. Toxicological information</li> <li>12. Ecological information*</li> <li>13. Disposal considerations*</li> <li>14. Transport information*</li> <li>15. Regulatory information*</li> <li>16. Other information (including date of SDS or last revision)</li> </ol>
-------------------------------------------------------------------------------------------------------------------------------------------------------------------------------------------------------------------------------------------------------------------------------------------------------------------------------	----------------------------------------------------------------------------------------------------------------------------------------------------------------------------------------------------------------------------------------------------------------------------------------------------------------------------------------------------------------------------------------------

\* Not required by OSHA

## OSHA Pictograms

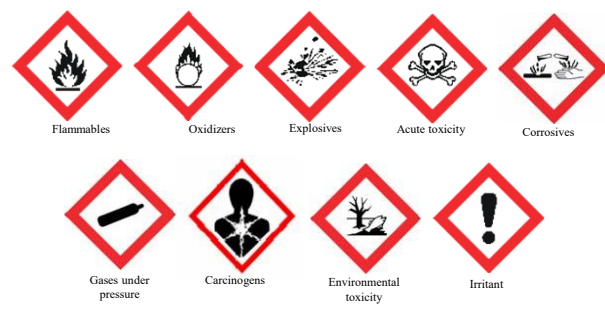

## Personal Protective Equipment

- Gloves
- Coveralls / Overalls
- Face Shield / Goggles
- Respirator / SCBA
- Boots
- Ear Plugs / Muffs



## Terms

- Lower Explosive Level (LEL) – minimum concentration of flammable gas or vapor in air that supports combustion
- Upper Explosive Limit (UEL) – maximum concentration of flammable gas or vapor in air that will support combustion
- Teratogen – causes structural abnormality following fetal exposure during pregnancy
- Mutagen – capable of altering a cell's genetic makeup







## Trenching Safety

## Trenching Safety

- Reduction of injury and illness rates.
- Daily exposure to job hazards by thousands of workers.
- Efficiency can be greatly improved.
- OSHA safety standards require:
  - Establishment of a "Safety" program
  - Training be conducted
  - Job hazards be assessed
  - Hazards and precautions be explained



## Excavation Hazards

- Cave-ins are the greatest risk
- Other hazards include:
  - Asphyxiation due to lack of oxygen
  - Inhalation of toxic materials
  - Fire
  - Moving machinery near the edge of the excavation can cause a collapse
  - Accidental severing of underground utility lines

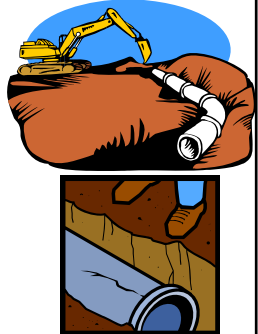

### Cave-ins

- Hundreds of workers killed annually from cave-ins
- Thousand of workers injured annually from cave-ins
- Fatality rate for trenching is twice the level for general construction

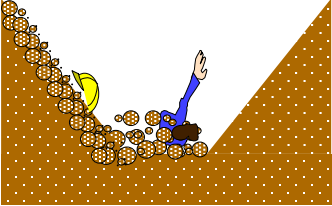

### Injury and Death

- Excavating is one of the most hazardous construction operations
- Most accidents occur in trenches 5-15 feet deep
- There is usually no warning before a cave-in

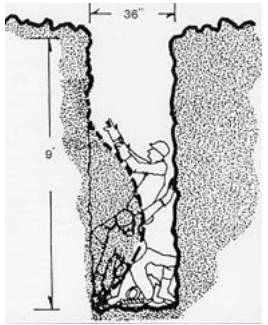

### Asphyxiation

- Each time a breath is exhaled the weight of the load restricts inhalation of the next breath
- Slow suffocation usually follows unless rescue is immediate

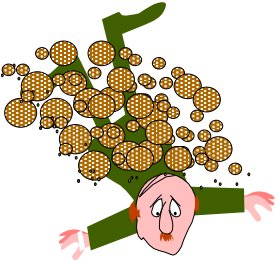

### Cave-ins Result From

- Vibrations
- Adjacent structures
- Freezing and thawing
- Weight of the soil itself
- Addition or removal of water
- Reduction in frictional and cohesive capacities of soil

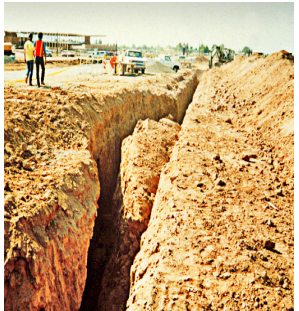

### Density and Water Content

- One cubic yard weighs - 3000 lbs or more
- One cubic foot weighs - 100 lbs or more

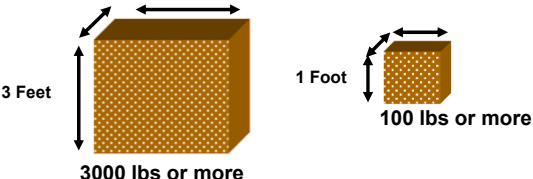

### How do most deaths occur?

- Instantaneously
- Trenches 5 to 15 feet deep
- With absolutely no warning
- In seemingly safe conditions
- With workers in a bent or lying position



### Before you begin excavation:

- The site must be assessed
- Potential hazards must be determined
- Known hazards reduced or eliminated
- Emergency procedures established
- Periodic inspection intervals determined
- Utility locations must be staked or marked
  
- Regardless of the equipment used, a sewer trench must be kept as narrow as possible

### Before you dig

- Call Tennessee One-Call at 811 to locate underground Utility locations must be staked or marked
- State law requires three business days notice for locating lines

APWA UNiform Color code of marked underground utility lines

White	Proposed excavation
Pink	Temporary survey markings
Red	Electric power lines, cables, conduit, and lighting cables
Yellow	Gas, oil, steam, petroleum, or gaseous materials
Orange	Communication, alarm, or signal lines, cables or conduit
Blue	Potable water
Purple	Reclaimed water, irrigation, and slurry lines
Green	Sewer and drain lines

### Basic Safety Requirements

- Conduct inspections before each work shift
- Do not travel under elevated loads
- Do not work over unprotected employees
- Wear proper personal protective equipment
- Provide walkways or bridges over trenches

### Basic Safety Requirements

- Provide trench exits within 25 feet of workers in trenches more than four feet deep
  - For every 25 feet of trench there needs to be 1 ladder
- Ensure spoilage is at least 2 ft. from trench edges
- Provide protection for trenches 5 feet or deeper
  - Shores needed
- A registered professional engineer (RPE) must design protective systems for excavations deeper than 20 feet

### Emergency Procedures

- Immediately call 911, or the Emergency Response Team
- Report:
  - Exact Location
  - Number of Victims
  - Nature of Emergency
  - Trench Measurements
  - Special Hazards



### Structural Ramps: Access & Egress

- Used only by people
- Designed by a "competent person"
- Egress required every 25 feet
  - (lateral) ≥ 4ft

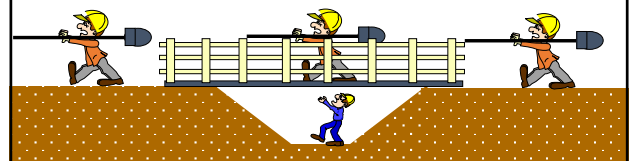

## Trench Safety

- Trenches more than 5 feet deep
  - Require shoring
  - Or must have a stabilized slope
- In hazardous soil conditions
  - Trenches under 5 feet need protection

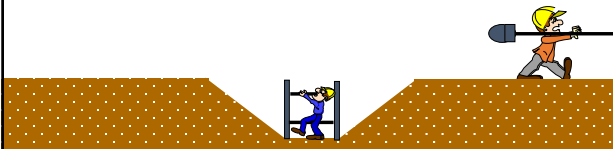

## Hazardous Atmospheres

- Testing and controls
  - Oxygen deficiency
  - Flammable atmospheres
  - Toxicity
- Emergency rescue equipment
  - Availability
  - Lifelines





## Hazards

- Adequate precautions must be taken when working in accumulated water
- Controlling water and water removal must be monitored by a competent person
- Ditches, dikes or comparable means should be used to prevent surface water from entering excavations



## Weather Factors - Mother Nature

- Don't underestimate the effects weather can have
- Daily (or hourly) site inspections must be made
- Consider protection from:
  - Lightening
  - Flooding
  - Erosion
  - High winds
  - Hot or cold temperatures



## Site Inspections

- Daily inspections must be made by a competent person
  - Excavations
  - Adjacent areas
  - Protective systems
- When evidence is found of a hazardous condition, the exposed employees must be immediately removed from the area



Feature identified by Compliance Officer. Entire area around feature collapsed into trench within minutes of initiating the inspection.

## Fall Protection

- Guardrails must be provided for crossing over excavations if the trench is 6 feet or more in depth
- Barriers must be provided for remotely located excavations

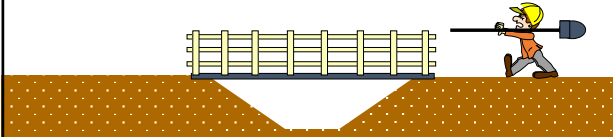

### Soil Classification System

- Type A Soils
  - Clay
  - Silty Clay
  - Sandy Clay
  - Clay Loam
- Type B Soils
  - Granular Cohesionless Soils (Silt Loam)
- Type C Soils
  - Gravel
  - Sand
  - Loamy Sand

### Soil Classification System

- Must be done by a competent person
- Visual test:
  - Check entire worksite
  - Fissured ground
  - Layered soil
  - Disturbed earth
  - Seepage
  - Vibration
  - Poor drainage

### Soil Classification System

- Manual test
  - Plasticity
  - Dry strength
  - Thumb penetration
  - Pocket penetrometer
  - Hand operated shear vane
- Warning:
  - One soil inspection and classification may not be enough
  - Outside disturbances during excavation may change even the best soil classification
  - Inspect the soil after any change in conditions

### Requirements for Protective Systems

- Each employee must be protected from cave-ins by an adequately designed system
- Exceptions are:
  - Excavation made in stable rock
  - Excavations less than 5 feet
- Protective systems must have the capacity to resist all loads that are expected to be applied to the system

### Materials and Equipment

- Must be free from damage or defects that might impair proper function
- Must be used and maintained in a manner that is consistent with the recommendations of the manufacturer
- Must be examined by a competent person if damage occurs

### Installation and Removal of Support

- General requirements:
  - Support systems must be securely connected
  - Support systems must be installed and removed in a manner that protects from collapse
  - Support systems must not be subjected to loads exceeding design specifications



### Installation and Removal of Support

- General requirements:
  - Additional precautions must be taken to ensure safety before temporary removal begins
  - Removal must begin at the bottom of the excavation
  - Backfilling must progress together with the removal of support systems from excavations



### Protect Employees Exposed to Potential Cave-ins

- Slope or bench the sides of the excavation,
- Support the sides of the excavation, or
- Place a shield between the side of the excavation and the work area

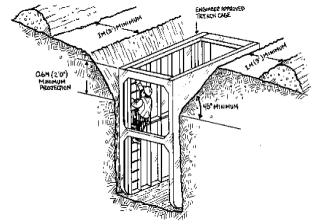

### Sloping and Benching Systems

- Employees must not be permitted to work:
  - On the faces of sloped or benched excavations
  - At levels above other employees except when employees at the lower levels are adequately protected from the hazard of falling, rolling or sliding material or equipment

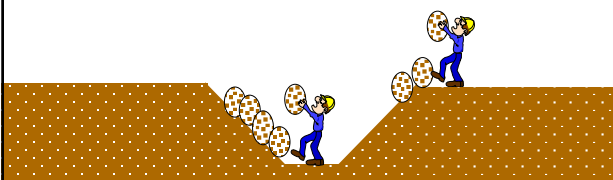

### Sloping and Benching Systems

- Temporary spoil piles:
  - 2 FEET MINIMUM



### Spoils

- Don't place spoils within 2 feet from edge of excavation
- Measure from nearest part of the spoil to the excavation edge
- Place spoils so rainwater runs away from the excavation
- Place spoil well away from the excavation



### Sloping and Benching Systems

- Benching general requirements
  - Various slope angles are allowed by OSHA
  - Appendix B to 1926 Subpart P must be consulted
  - Evacuate the excavation if walls show signs of distress
  - If soil conditions change, re-inspect

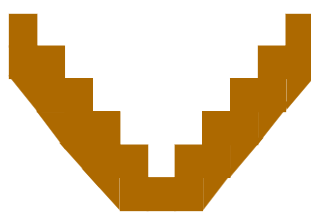

### Sloping and Benching Systems

➤ The angle of repose is the angle of slope of the unsupported loose soil

90 Degrees	53 Degrees Maximum
<b>STABLE ROCK</b>	<b>TYPE A</b>
45 Degrees Maximum	34 Degrees Maximum
<b>TYPE B</b>	<b>TYPE C</b>

### Sloping Example Type A Soils

20 FEET MAX

**TYPE A SOILS**

53°

3/4

1

### Sloping Example Type B Soils

20 FEET MAX

**TYPE B SOILS**

45°

1

1

### Sloping Example Type C Soils

20 FEET MAX

**TYPE C SOILS**

34°

1 1/2

1

### Shoring Systems

JACKS/CROSSBRACES

SHEETING

WALES

### Shoring

- General
  - Provides a framework to work in
  - Uses wales, cross braces and uprights
  - Supports excavation walls
- OSHA tables provide shoring data
  - Must know soil type
  - Must know depth and width of excavation
  - Must be familiar with the OSHA Tables

### Shoring Systems

- Removal
  - Remove shoring from the bottom up
  - Pull sheeting out from above
  - Backfill immediately after removal of support system

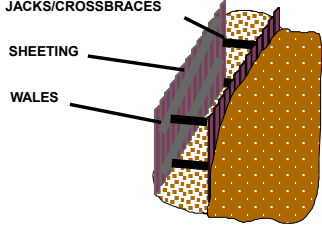

### Hydraulic Trench Support

- Using hydraulic jacks the operator can easily drop the system into the hole
- Once in place, hydraulic pressure is increased to keep the forms in place
- Trench pins are installed in case of hydraulic failure



### Shoring Systems

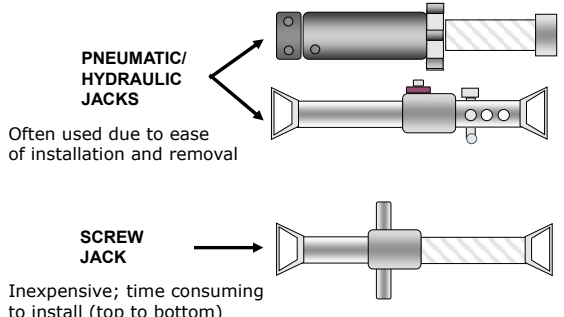

**PNEUMATIC/HYDRAULIC JACKS**  
Often used due to ease of installation and removal

**SCREW JACK**  
Inexpensive; time consuming to install (top to bottom)

### Shield Systems

- General
  - Shield systems must project at least 18 inches above the lowest point where the excavation face begins to slope

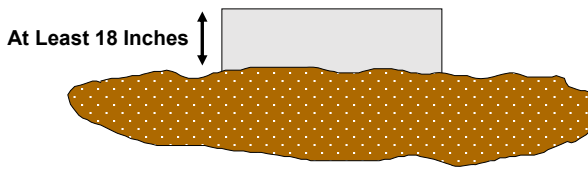

### Shield Systems

- General
  - Shield systems must not be subjected to loads exceeding those which the system was designed to withstand
  - Shields must be installed to restrict hazardous movement
  - Employees must be protected from the hazard of cave-ins when entering or exiting the areas protected by shields
  - Employees must not be allowed in shields when shields are being installed, removed, or moved vertically

### Shield Systems

- Systems may be connected
- Systems may be stacked
- Configuration must be consistent with the recommendations of the manufacturer
- Must be examined by a competent person if damage occurs

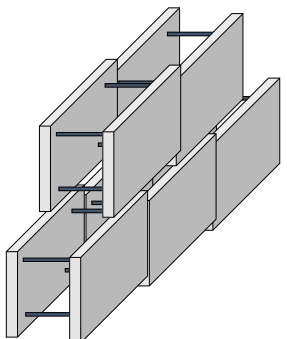

### Trench Shield

- A trench shield was built around this work area



### Cave-in Hazard



**Inadequate protective system**

←

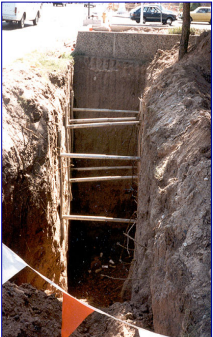

**This excavation has inadequate support posts and egress access**

→

### Hazardous Conditions

- The weight and vibrations of the crane make this a very hazardous condition
- They should not be working under this crane



### Materials and Equipment

- Equipment used for protective systems must not have damage or defects that impair function
- If equipment is damaged, the competent person must examine it to see if it is suitable for continued use
- If not suitable, remove it from service until a professional engineer approves it for use



### Protection from Vehicles

- Install barricades
- Hand/mechanical signals
- Stop logs
- Grade soil away from excavation
- Fence or barricade trenches left overnight



### Trenching Summary

- Provide stairways, ladders, ramps or other safe means of access in all trenches **4 feet** or deeper
  - These devices must be located within **25 feet** of all workers
  - Ladders used in trenches shall protrude at least **3 feet** above the trench edge
  - Minimum diameter of rungs on a fixed steel ladder is **¾-inch**
  - Minimum clear length of rungs on a fixed steel ladder is **16 inches**

## Trenching Summary

- Trenches **5 feet** deep or greater require a protective system, which can be shielding, shoring or sloping
  - A registered engineer must approve all shielding and shoring
- Trenches **20 feet** deep or greater require that the protective system be designed by a registered professional engineer
- Keep excavated soil (spoils) and other materials at least **2 feet** from trench edges
- The support or shield system must extend at least **18 inches** above the top of the vertical side

## TOSHA Standards Requiring Annual Training

Class	Regulation	Who should attend?
Medical & Exposure Records	1910.20(g)(1)	All employees (inform-existence, person responsible, location, right of access)
Emergency Action	1910.38(a)(5) 1910.38(b)(4)	All employees – based upon other standards and requirements
Noise	1910.95(k)	All employees exposed to an 8 hour TWA or greater of 85dBA
Emergency Response	1910.120(q)	Employees who respond to spills of hazardous chemicals
Personal Protective Equipment	1910.132(f)	Employees who wear PPE
Permit-Required Confined Space	1910.146(g)	Employees who enter, attend or supervise P.R. confined spaces
Lock-Out/Tag-Out	1910.147(c)(7)	Employees who work on machinery
First Aid	1910.151(b)	At least one employee on each shift, annual as required by other standards
Fire Brigade	1910.156(c)	All fire brigade members (quarterly and annually)
Portable Fire Extinguishers	1910.157(g)	All employees expected to use fire extinguishers
Fork Lift Trucks	1910.178(1)	Fork lift truck operators
Mechanical Power Presses	1910.217(f)(2)	Operators
Asbestos	1910.1001(j)(1)	All employees exposures at or above PEL or excursion limit
Lead	1910.1025(1)	Anyone with a potential for exposure at any level – copy of appendix A&B. If exposed at or above action level, must be trained
Bloodborne Pathogens	1910.1030(g)(2)	Employees who render first aid
Hazard Communication	1910.1200(h) TDL 800-1-9-.07	Employees exposed or potentially exposed to any type of chemicals
Hazardous Chemicals in Laboratories	1910.1450(f)(2)	Employees exposed to chemicals

## Safety Vocabulary

<p>_____ 1. Aerobic</p> <p>_____ 2. Ambient</p> <p>_____ 3. Anaerobic</p> <p>_____ 4. Competent Person</p> <p>_____ 5. Confined Space</p> <p>_____ 6. Confined Space, Non-Permit</p> <p>_____ 7. Confined Space, Permit- Required</p> <p>_____ 8. Decibel</p> <p>_____ 9. Engulfment</p>	<p>_____ 10. Fit Test</p> <p>_____ 11. IDLH</p> <p>_____ 12. Mercaptans</p> <p>_____ 13. Olfactory Fatigue</p> <p>_____ 14. Oxygen Deficiency</p> <p>_____ 15. Oxygen Enrichment</p> <p>_____ 16. Septic</p> <p>_____ 17. Sewer Gas</p> <p>_____ 18. Spoil</p>
----------------------------------------------------------------------------------------------------------------------------------------------------------------------------------------------------------------------------------------------------------------------------------------------	----------------------------------------------------------------------------------------------------------------------------------------------------------------------------------------------------------------------------------------------------------------

- A. A condition where atmospheric or dissolved molecular oxygen is not present in the aquatic (water) environment.
- B. A unit for expressing the relative intensity of sounds on a scale from zero for the average least perceptible sound to about 130 for the average level where sound causes pain to humans. Abbreviated dB.
- C. A space which is large enough and so configured that an employee can bodily enter and perform assigned work; has limited or restricted means for entry or exit and it not designed for continuous employee occupancy.
- D. Compounds containing sulfur that have an extremely offensive skunk-like odor; also sometimes described as smelling like garlic or onions.
- E. The use of a procedure to qualitatively or quantitatively evaluate the fit of a respirator on an individual.
- F. An atmosphere containing oxygen at a concentration of less than 19.5% by volume.
- G. A condition where atmospheric or dissolved molecular oxygen is present in the aquatic (water) environment.
- H. A condition produced by anaerobic bacteria. If severe, the wastewater produces hydrogen sulfide, turns black, gives off foul odors, contains little or no dissolved oxygen and the wastewater has a high oxygen demand.
- I. Immediately Dangerous to Life or Health. The atmospheric concentration of any toxic, corrosive or asphyxiant substance that poses an immediate threat to life or would cause irreversible or delayed adverse health effects or would interfere with an individual's ability to escape from a dangerous atmosphere.
- J. Gas in collection lines (sewers) that result from the decomposition of organic matter in the wastewater. When testing for gases found in sewers, test for lack of oxygen and also for explosive and toxic gases.
- K. A person capable of identifying existing and predictable hazards in the surroundings, or working conditions that are unsanitary, hazardous or dangerous to employees, and who has authorization to take prompt corrective measures to eliminate the hazards.
- L. Excavated material such as soil from the trench of a sewer.

- M. The surrounding and effective capture of a person by a liquid or finely divided (flowable) solid substance that can be aspirated to cause death by filling or plugging the respiratory system or that can exert enough force on the body to cause death by strangulation, constriction or crushing.
- N. A condition where a person's nose, after exposure to certain odors, is no longer able to detect the odor.
- O. A confined space that does not contain or, with respect to atmospheric hazards, have the potential to contain any hazard capable of causing death or serious physical harm.
- P. An atmosphere containing oxygen at a concentration of more than 23.5% by volume.
- Q. Surrounding. Ambient or surrounding atmosphere.
- R. A confined space that has one or more of the following characteristics: contains or has the potential to contain a hazardous atmosphere; contains a material that has the potential for engulfing an entrant; has an internal configuration such that an entrant could be trapped or asphyxiated by inwardly converging walls or by a floor that slopes downward and tapers to a smaller cross section; or contains any other recognized serious safety or health hazard.

### Safety Questions

1. How can traffic be warned of your presence in the street?
2. What is the purpose of the advance warning area?
3. List six types of traffic control devices.
4. How can explosive or flammable atmosphere develop in a collection system?
5. What types of hazardous atmospheres should an atmospheric test unit be able to detect in confined spaces?



6. If operators are scheduled to work in a manhole, when should the atmosphere in the manhole be tested?
  
7. When a blower is used to ventilate a manhole, where should the blower be located?
  
8. List the safety equipment recommended for use when operators are required to enter a confined space.
  
9. What are some early signs that an operator working in a manhole or other confined space is not getting enough oxygen?
  
10. How can system operators be protected from injury by the accidental discharge of stored energy?
  
11. How can system operators protect their hearing from loud noises?
  
12. How would you extinguish a fire?

## Answers to Vocabulary and Questions

## Vocabulary:

- |      |      |       |       |       |
|------|------|-------|-------|-------|
| 1. G | 5. C | 9. M  | 13. N | 17. J |
| 2. Q | 6. O | 10. E | 14. F | 18. L |
| 3. A | 7. R | 11. I | 15. P |       |
| 4. K | 8. B | 12. D | 16. H |       |

## Questions:

1. Traffic can be warned of your presence in a street by signs, flags or flashers and vehicles with rotating flashing lights. Vehicle-mounted traffic guides are also helpful. Flaggers can be used to alert drivers and to direct traffic around a work site.
2. The purpose of the advance warning area is to give drivers enough time to see what is happening ahead and adjust their driving patterns.
3. Types of traffic control devices include: signs, barricades, traffic cones, drums, vertical panels, lighting devices, advance warning arrow boards, flashing vehicle lights, high level warning devices and portable changeable message signs. Flaggers may also be used to control traffic.
4. Explosive or flammable atmospheres can develop at any time in the collection system. Flammable gases or vapors may enter a sewer or manhole from a variety of legal, illegal or accidental sources.
5. An atmospheric test unit should be able to detect flammable and explosive gases, toxic gases and oxygen deficiency.
6. If operators are scheduled to work in a manhole, the atmosphere in the manhole should be tested before anyone enters it, preferably before the cover is even removed, and atmospheric testing should continue for the entire time anyone is working in the manhole.
7. The blower used to ventilate a manhole should be located in an area upwind of the manhole and at least 10 feet from the manhole opening. If the blower has a gas-driven engine, the exhaust must be downwind from the manhole. The air intake to the blower should be 2-5 feet above the ground surface, depending on conditions (higher for dusty conditions).
8. SCBA (self-contained breathing apparatus); safety harness with lifeline, tripod and winch; portable atmospheric alarm unit; ventilation blower with hose; manhole enclosure (if entering a manhole); ladder or tripod with winch; ropes and buckets; hard hats; protective clothing; cones and barricades; first-aid kit; soap, water, paper towels and a trash bag
9. The early warning signs that an operator is not getting enough oxygen include: labored breathing (shortness of breath), chest heaving and change from usual responses
10. Operators can be protected from injury due to the accidental discharge of stored energy by following prescribed lockout/ tagout procedures.
11. Collection system operators can protect their hearing from loud noises by use of approved earplugs, earmuffs and/or person protective equipment.
12. To extinguish a fire, first identify the material burning (class or category) and then use the appropriate method to put out the fire.

**Section 11**  
**Pumps & Maintenance**



# Pumps



California State University: Sacramento

Updated 12-2023

## Objectives

- Classification of Pumps
- Positive Displacement Pumps
- Velocity Pumps
- Parts of a Centrifugal Pumps
- Pump Operations



## Classification of Pumps

## Necessity Of Pumps

- Pumps are required when gravity cannot supply water with sufficient pressure to all parts of the distribution system
- Pumps account for the largest energy cost for a water supply operation

## Types of Pumps

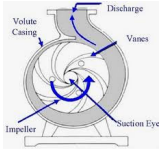
- Velocity Pumps
 
- Positive-Displacement Pumps
 

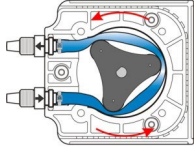
## Types of Pumps

- Positive-Displacement Pumps
  - Metering pumps
    - sometimes used to feed chemicals
  - Piston pump
  - Screw pump
- Velocity Pumps
  - Vertical turbine
  - Centrifugal

# Positive Displacement Pumps



## Positive-Displacement Pumps

- Chemical feed pumps
- Delivers a constant volume with each stroke
- Less efficient than centrifugal pumps
- **Cannot operate against a closed discharge valve**
- Types: piston, diaphragm, gear, or screw pump

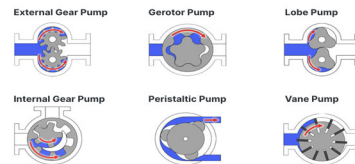

## Positive-Displacement Pumps

- Metering pumps – most common type of solution feeder
- Delivers precise volume of solution with each stroke or rotation
- Typically have variable-speed motor that can be adjusted to control chemical flow

## Reciprocating Pump

- aka Piston Pump
- Piston moves back and forth in a cylinder; liquid enters and leaves through check valves

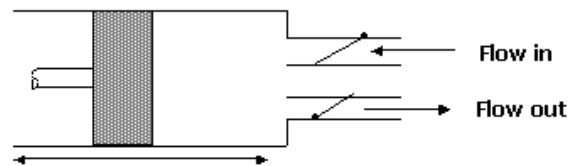

## Rotary Pumps

- Uses lobes or gears to move liquid through pump

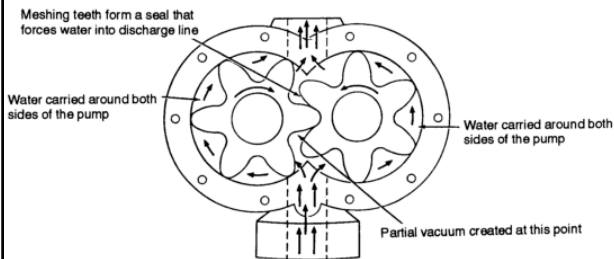

## Peristaltic Pumps

- Fluid to be pumped flows through flexible tube inside a pump casing
- Rotor inside turns and compresses the tube
- Rotor forces fluid through tube

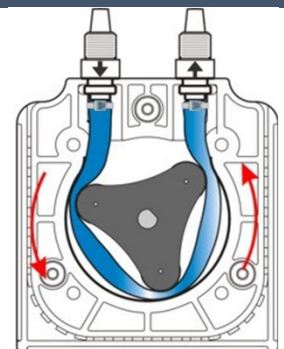

### Screw Pumps

- aka progressive cavity pumps
- Screw pumps are used to lift wastewater to a higher elevation
- This pump consists of a screw operating at a constant speed within a housing or trough
- The screw has a pitch and is set at a specific angle
- When revolving, it carries wastewater up the trough to a discharge point

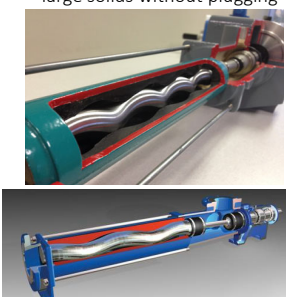

Incline screw pumps handle large solids without plugging



### Positive-Displacement Pumps



## Velocity Pumps

### Velocity Pumps

- Centrifugal (Volute) Pumps
  - Spinning impeller or propeller accelerates water to high velocity in pump casing (or volute)
  - High velocity, low pressure water converted to high pressure, low velocity water
- Turbine Pumps
  - Velocity head is converted to pressure head by diffuser guide vanes

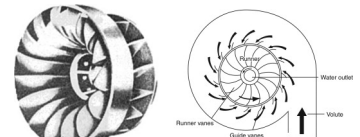

### Velocity Pump Design Characteristics

- Axial - flow designs
  - Propeller shaped impeller adds head by lifting action on vanes
  - Water moves parallel to pump instead of being thrown outward
  - High volume, but limited head
  - Not self-priming

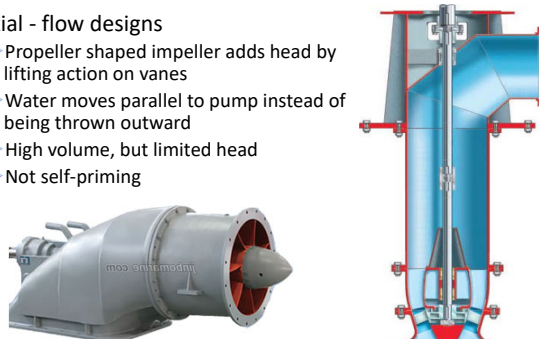

### Velocity Pump Design Characteristics

- Radial flow designs
  - Water comes in through center (eye) of impeller
  - Water thrown outward from impeller to diffusers that convert velocity to pressure
  - The discharge is perpendicular to the pump shaft
  - Centrifugal or Turbine

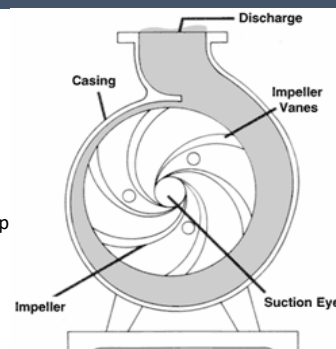

## Velocity Pump Design Characteristics

- Mixed - flow designs
  - Has features of axial and radial flow
  - Works well for water with solids

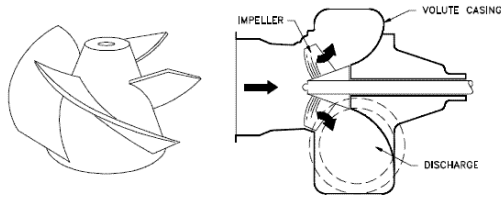

## Centrifugal Pump

- Basically, a very simple device: an impeller rotating in a casing
- The impeller is supported on a shaft, which in turn, is supported by bearings
- Liquid coming in at the center (eye) of the impeller is picked up by the vanes and by the rotation of the impeller and then is thrown out by centrifugal force into the discharge

## Centrifugal Pumps

- Volute-casing type most commonly used in water utilities
- Impeller rotates in casing - radial flow
- Single or multi-stage
- By varying size, shape, and width of impeller, a wide range of flows and pressures can be achieved

## Advantages of Centrifugal Pumps

- Wide range of capacities
- Uniform flow at a constant speed and head
- Low cost
- Ability to be adapted to various types of drivers
- Moderate to high efficiency
- No need for internal lubrication if pumping clean water

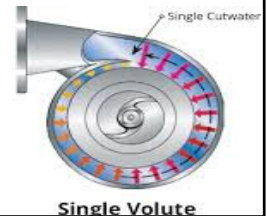

## Disadvantages of Centrifugal Pumps

- Efficiency is limited to very narrow ranges of flow and head
- Flow capacity greatly depends on discharge pressure
- Generally, no self-priming ability
- Can run backwards if check valve fails and sticks open
- Potential impeller damage if pumping abrasive water

## Parts of a Centrifugal Pump



## Let's Build a Centrifugal Pump

- First, we need a device to spin liquid at high speeds – an impeller
  - As the impeller spins, liquid between the blades is impelled outward by centrifugal force
  - As liquid in the impeller moves outward, it will suck more liquid behind it through this eye

*#1: If there is any danger that foreign material may be sucked into the pump, clogging or wearing of the impeller unduly, provide the intake end of the suction piping with a suitable screen*

## Impeller

- Bronze or stainless steel
- Closed; some single-suction have semi-open; open designs
- Inspect regularly
- As the impeller wears on a pump, the pump efficiency will decrease

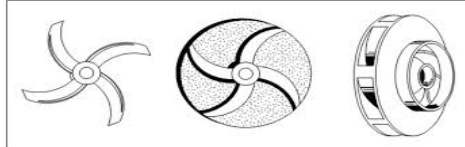

## Let's Build a Centrifugal Pump

- Now we need a shaft to support and turn the impeller
  - It must maintain the impeller in precisely the right place
  - But that ruggedness does not protect the shaft from the corrosive or abrasive effects of the liquid pumped, so we must protect it with sleeves slid on from either end

*#2: Never pump a liquid for which the pump was not designed*

## Pump Shaft and Shaft Sleeves

- Pump Shaft
  - Connects impeller to pump; steel or stainless steel
  - Should be repaired/replaced if grooves or scores appear on the shaft
- Shaft Sleeves
  - Protect shaft from wear from packing rings
  - Generally, they are bronze, but various other alloys, ceramics, glass or even rubber-coating are sometimes required

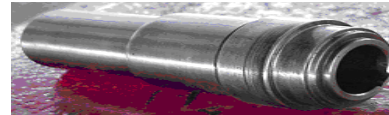

## Let's Build a Centrifugal Pump

- We mount the shaft on sleeve, ball or roller bearings
  - If bearings supporting the turning shaft and impeller are allowed to wear excessively and lower the turning units within a pump's closely fitted mechanism, the life and efficiency of that pump will be seriously threatened

*#3: Keep the right amount of the right lubricant in bearings at all times.*

## Bearings

- Anti-friction devices for supporting and guiding pump and motor shafts
- Get noisy as they wear out
- If pump bearings are over lubricated, the bearings will overheat and can be damaged or fail
  - Tiny indentations high on the shoulder of a bearing or race is called brinelling
  - When greasing a bearing on an electric motor, the relief plug should be removed and replaced after the motor has run for a few minutes. This prevents you from damaging the seals of the bearing
- Types: ball, roller, sleeve



## Let's Build a Centrifugal Pump

- To connect with the motor, we add a coupling flange
  - Our pump is driven by a separate motor, and we attach a flange to one end of the shaft through which bolts will connect with the motor flange
  - If shafts are met at an angle, every rotation throws tremendous extra load on bearings of both pump and the motor

#4: See that pump and motor flanges are parallel and vertical and that they stay that way.

## Couplings

- Connect pump and motor shafts
- Lubricated require greasing at 6-month intervals
- Dry has rubber or elastomeric membrane
- Calipers and thickness gauges can be used to check alignment on flexible couplings

## Misalignment of Pump & Motor

- Excessive bearing loading
- Shaft bending
- Premature bearing failure
- Shaft damage
- Checking alignment should be a regular procedure in pump maintenance.
  - Foundations can settle unevenly
  - Piping can change pump position
  - Bolts can loosen
  - Misalignment is a major cause of pump and coupling wear

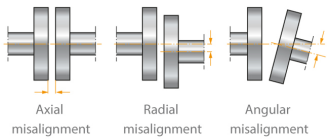

## Common Pump & Motor Connections

- Close-coupled
- Frame mounted
  - Direct coupling
  - Angle drive
  - Belt or chain
  - Flexible coupling

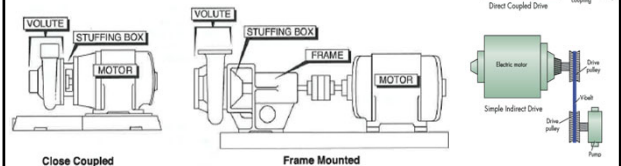

## Let's Build a Centrifugal Pump

- Now we need a "straw" through which liquid can be sucked
  - The horizontal pipe slopes upward toward the pump so that air pockets won't be drawn into the pump and cause loss of suction

#5: Any down-sloping toward the pump in suction piping should be corrected



## Let's Build a Centrifugal Pump

- We contain and direct the spinning liquid with a casing
  - Designed to minimize friction loss as water is thrown outward from impeller
  - Usually made of cast iron, spiral shape

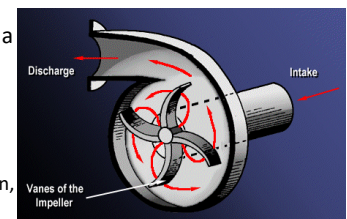

#6: See that piping puts absolutely no strain on the pump casing.

## Mechanical Details of Centrifugal Pumps

- **Casing**
  - Housing surrounding the impeller; also called the volute
  - Designed to minimize friction loss as water is thrown outward from impeller
  - Usually made of cast iron, spiral shape

## Let's Build a Centrifugal Pump

- Now our pump is almost complete, but it would leak like a sieve
  - As water is drawn into the spinning impeller, centrifugal force causes it to flow outward, building up high pressure at the outside of the pump (which will force water out) and creating low pressure at the center of the pump (which will draw water in)
  - Water tends to be drawn back from pressure to suction through the space between the impeller and casing – this needs to be plugged

## Let's Build a Centrifugal Pump

- So, we add wear rings to plug internal liquid leakage
  - Wear rings fill the gaps without having to move the parts of the pump closer together

*#7: Never allow a pump to run dry. Water is a lubricant between the rings and impeller.*

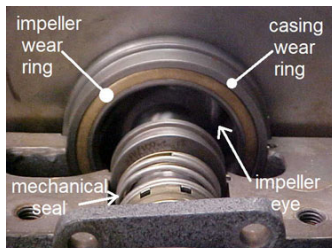

## Wear Rings

- Restrict flow between impeller discharge and suction
- Leakage reduces pump efficiency
- Installed to protect the impeller and pump casing from excessive wear
- Provides a replaceable wearing surface
- Inspect regularly

*#8: Examine wearing rings at regular intervals. When seriously worn, their replacement with greatly improve pump efficiency.*

## Let's Build a Centrifugal Pump

- To keep air from being drawn in, we use stuffing boxes
  - We have two good reasons for wanting to keep air out of our pump
    - We want to pump water, not air
    - Air leakage is apt to cause our pump to lose suction
  - Each stuffing box we use consists of a casing, rings of packing, seal cage and a gland at the outside end
    - A mechanical seal may be used instead

## Packing Rings

- Asbestos or metal ring lubricated with Teflon or graphite
- Provides a seal where the shaft passes through the pump casing in order to keep air from being drawn or sucked into the pump and/or the water being pumped from coming out

## Packing Rings

- If new packing leaks, stop the motor and repack the pump
- Pumps need new packing when the gland or follower is pulled all the way down
- The packing around the shaft should be tightened slowly, over a period of several hours to just enough to allow an occasional drop of liquid
  - Leakage acts as a lubricant
- Stagger packing joints
  - 180° if only 2 rings are in stuffing box
  - 120° for 3 rings
  - 90° if 4 rings or more are in set

## Packing Rings

- If packing is not maintained properly, the following troubles can arise:
  - **Loss of suction** due to air being allowed to enter pump
  - **Shaft or shaft sleeve damage**
  - Water or wastewater **contaminating bearings**
  - **Flooding** of pump station
  - Rust corrosion and unsightliness of pump and area

## Lantern Rings (aka Seal Cage)

- Perforated ring placed in stuffing box
- A spacer ring in the packing gland that forms seal around shaft, helps keep air from entering the pump and lubricates packing

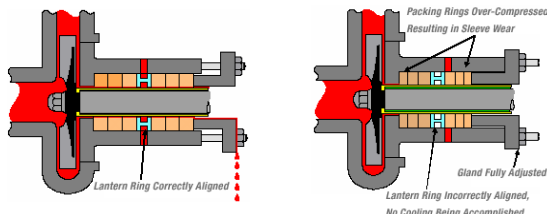

## Stuffing Box

*#9 – Packing should be replaced periodically. Forcing in a ring or two of new packing instead of replacing worn packing is bad practice. It is apt to dislodge the seal cage.*

*#10 – Never tighten a gland more than necessary as excessive pressure will wear shaft sleeves unduly.*

*#11 – If shaft sleeves are badly scored, replace them immediately.*

## Let's Build a Centrifugal Pump

- To make packing more airtight, we add water seal piping
  - In the center of each stuffing box is a "seal cage"
  - This liquid acts both to block out air intake and to lubricate the packing
  - To control liquid flow, draw up the packing gland just tight enough to **allow approximately one drop every 2-3 seconds** flow from the box

*#12 – If the liquid being pumped contains grit, a separate source of sealing liquid should be obtained.*

## Mechanical Seals



- Located in stuffing box
- Prevents water from leaking along shaft; keeps air out of pump
- **Should not leak**
- Consists of a rotating ring and stationary element
- **The operating temperature on a mechanical seal should never exceed 160°F (71°C)**
- Mechanical seals are always flushed in some manner to lubricate the seal faces and minimize wear
  - The flushing water pressure in a water-lubricated wastewater pump should be **3-5 psi higher** than the pump discharge pressure

## Mechanical Seals

- Required instead of packing rings for suction head greater than 60 psi
- Prevents water from leaking along shaft, keeps air out of pump
  - Should not leak any water

## Packing vs. Mechanical Seals

- If a pump has packing, water should drip slowly
- If it has a mechanical seal, no leakage should occur

## Packing Rings vs. Mechanical Seal

- |                                                                                                                                                     |                                                                                                                                                                                              |
|-----------------------------------------------------------------------------------------------------------------------------------------------------|----------------------------------------------------------------------------------------------------------------------------------------------------------------------------------------------|
| <p>➤ <b>Advantages</b></p> <ul style="list-style-type: none"> <li>➤ Less expensive, short term</li> <li>➤ Can accommodate some looseness</li> </ul> | <p>➤ <b>Disadvantages</b></p> <ul style="list-style-type: none"> <li>➤ Increased wear on shaft or shaft sleeve</li> <li>➤ Increased labor required for adjustment and replacement</li> </ul> |
|-----------------------------------------------------------------------------------------------------------------------------------------------------|----------------------------------------------------------------------------------------------------------------------------------------------------------------------------------------------|

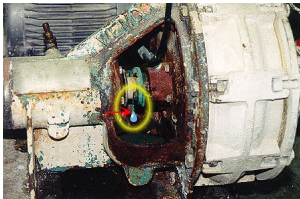

## Mechanical Seal vs. Packing Rings

- |                                                                                                                                                                                                                                                                                                                                                                                                                                     |                                                                                                                                                                                                                                                          |
|-------------------------------------------------------------------------------------------------------------------------------------------------------------------------------------------------------------------------------------------------------------------------------------------------------------------------------------------------------------------------------------------------------------------------------------|----------------------------------------------------------------------------------------------------------------------------------------------------------------------------------------------------------------------------------------------------------|
| <p>➤ <b>Advantages</b></p> <ul style="list-style-type: none"> <li>➤ Last 3-4 years, which can be a savings in labor</li> <li>➤ Usually there is no damage to shaft sleeve</li> <li>➤ Continual adjusting, cleaning or repacking is not required</li> <li>➤ Possibility of flooding lift station because a pump has thrown its packing is eliminated; however mechanical seals can fail, and lift stations can be flooded</li> </ul> | <p>➤ <b>Disadvantages</b></p> <ul style="list-style-type: none"> <li>➤ High initial cost</li> <li>➤ Great skill and care needed to replace</li> <li>➤ When they fail, the pump must be shut down</li> <li>➤ Pump must be dismantled to repair</li> </ul> |
|-------------------------------------------------------------------------------------------------------------------------------------------------------------------------------------------------------------------------------------------------------------------------------------------------------------------------------------------------------------------------------------------------------------------------------------|----------------------------------------------------------------------------------------------------------------------------------------------------------------------------------------------------------------------------------------------------------|

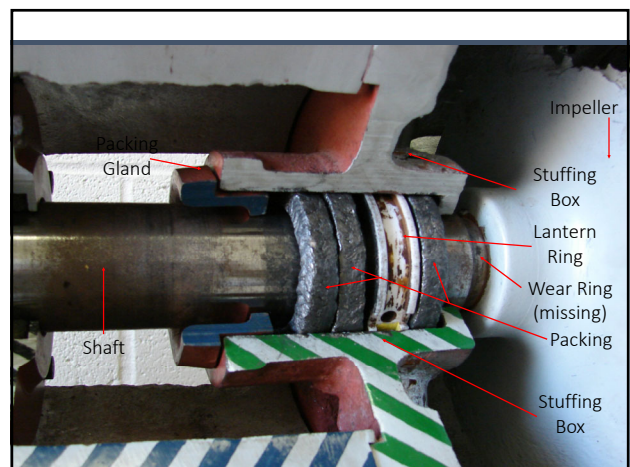
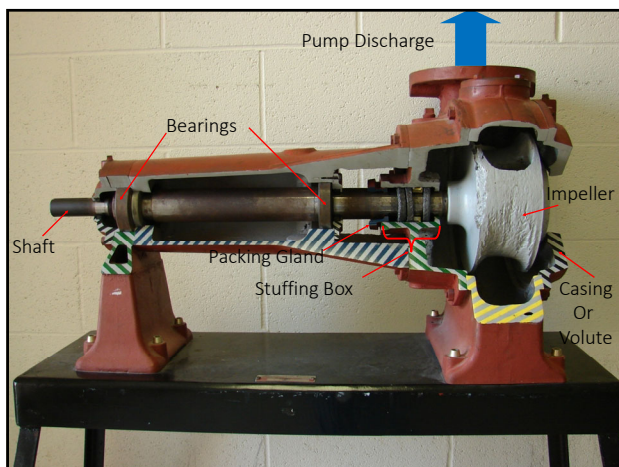
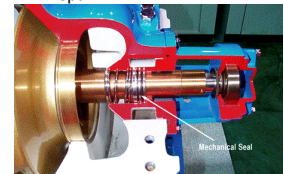

## Centrifugal Pump Components



## How Centrifugal Pumps Work



## Pump Operations



## Centrifugal Pump Operation

- Pump Starting -
  - Impeller must be submerged for a pump to start
    - Should never be run empty, except momentarily, because parts lubricated by water would be damaged
  - Foot valve helps hold prime
  - Discharge valve should open slowly to control water hammer
  - In small pumps, a check valve closes immediately when pump stops to prevent flow reversal
  - In large pumps, discharge valve may close before pump stops

## Centrifugal Pump Operation

- Pump shut down for extended period of time -
  - Close the valve in the suction line
  - Close the valve in the discharge line
  - Drain the pump casing

## Flow Control

- Flow usually controlled by starting and stopping pumps
- Throttling flow should be avoided - wastes energy
- Variable speed drives or motor are best way to vary flow
  - Variable speed pumping equipment can be adjusted to match the inflow rate

## Monitoring Operational Variables

- Pump and motor should be tested, and complete test results recorded as a baseline for the measurement of performance within the first 30 days of operation

## Monitoring Operational Variables

- Suction and Discharge Heads
  - Pressure gauges
- Bearing and Motor Temperature
  - Temp indicators can shut down pump if temp gets too high
  - Check temp of pump by feel
    - Do not touch a hot motor!

## Monitoring Operational Variables

- Vibration
  - Detectors can sense malfunctions causing excess vibration
  - Operators can learn to distinguish between normal and abnormal sounds



## Monitoring Operational Variables

- Likely causes of vibration
  - Bad bearings or bearing failure
  - Imbalance of rotating elements, damage to impeller
  - Misalignment from shifts in underlying foundation
  - Improper motor to pump alignment

## Monitoring Operational Variables



- Speed
  - Cavitation can occur at low and high speeds
  - Creation of vapor bubbles due to partial vacuum created by incomplete filling of the pump

## Monitoring Operational Variables

- Cavitation is a noise coming from a centrifugal pump that sounds like marbles trapped in the volute
- A condition where small bubbles of vapor form and explode against the impeller, causing a pinging sound
- Best method to prevent it from occurring is to reduce the suction lift

## Suction Cavitation

- Suction Cavitation occurs when the pump suction is under a low pressure/high vacuum condition where the liquid turns into a vapor at the eye of the pump impeller
- This vapor is carried over to the discharge side of the pump where it no longer sees vacuum and is compressed back into a liquid by the discharge pressure
- This imploding action occurs violently and attacks the face of the impeller
- An impeller that has been operating under a suction cavitation condition has large chunks of material removed from its face causing premature failure of the pump

## Discharge Cavitation

- Discharge Cavitation occurs when the pump discharge is extremely high
- It normally occurs in a pump that is running at less than 10% of its best efficiency point
- The high discharge pressure causes the majority of the fluid to circulate inside the pump instead of being allowed to flow out the discharge
- As the liquid flows around the impeller, it must pass through the small clearance between the impeller and the pump cutwater at extremely high velocity

## Discharge Cavitation

- This velocity causes a vacuum to develop at the cutwater similar to what occurs in a venturi and turns the liquid into a vapor
- A pump that has been operating under these conditions shows premature wear of the impeller vane tips and the pump cutwater
- In addition, due to the high-pressure condition, premature failure of the pump mechanical seal and bearings can be expected and under extreme conditions will break the impeller shaft

## Inspection and Maintenance

- Inspection and maintenance prolongs life of pumps
  - Checking operating temperature of bearings
  - Checking packing glands
  - Operating two or more pumps of the same size alternatively to equalize wear
  - Check parallel and angular alignment of the coupling on the pump and motor
    - A feeler gauge, dial indicator calipers are tools that can be used to check proper alignment
- Necessary for warranty
- Keep records of all maintenance on each pump
- Keep log of operating hours

## Inspection: Impellers

- Wear on impeller and volute
- Cavitation marks
- Chips, broken tips, corrosion, unusual wear
- Tightness on shaft
- Clearances
- Tears or bubbles (if rubber coated)



## Pump Won't Start?

- Incorrect power supply
- No power supply
- Incorrectly connected
- Fuse out, loose or open connection
- Rotating parts of motor jammed mechanically
- Internal circuitry open

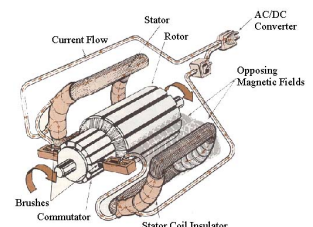

## Pump Safety

- Machinery should always be turned off and locked out/tagged out before any work is performed on it
- Make sure all moving parts are free to move and all guards in place before restarting
- Machinery creating excessive noise shall be equipped with mufflers



## Pump Safety: Meter Vaults & Manholes

- Confined spaces
- Corrosion of ladder rungs
- Explosive atmospheres
- Hydrogen sulfide accumulation
- Slippery surfaces



## Maintenance

- California State University, Sacramento
- Water Distribution Operation and Maintenance

## System Maintenance

- A good maintenance program is a must in order to maintain successful operation of a water plant
- Should include everything from mechanical equipment to the care of the plant grounds, buildings and structures
- Mechanical maintenance is of prime importance as the equipment must be kept in good operating condition in order for the plant to maintain peak performance

## Preventive Maintenance Records

- Preventive maintenance programs keep equipment in good working condition and correct small malfunctions before they turn into big problems
- A good record keeping system tells when maintenance is due and shows equipment performance
- Equipment service cards and service record cards should be filled out for each piece of equipment in the plant

## Equipment Service Card

- Tells what should be done and when
- Should include equipment name
  - e.g. raw pump No. 1
- List each required maintenance service with an item number
- List maintenance services in order of frequency of performance
- Describe each type of service under work to be done



EQUIPMENT SERVICE CARD Equipment: #1 Raw Pump			
Item No.	Work to be done	Frequency	Time
1	Check water seal and packing gland	Daily	
2	Listen for unusual noises	Daily	
3	Operate pump alternately	Weekly	Monday
4	Inspect pump assembly	Weekly	Wednesday
5	Inspect and lube bearings	Quarterly	1, 4, 7, 10
6	Check operating temperature of bearings	Quarterly	1, 4, 7, 10
7	Check alignment of pump and motor	Semi-annually	4, 10
8	Inspect and service pump	Semi-annually	4, 10
9	Drain pump before shutdown		

### Service Record Card

- Tells what was done and when it was done
- Should have date and work done, listed by item number and signed by the operator who performed the service

SERVICE RECORD CARD Equipment: #1 Raw Pump					
Date	Work Done (Item No.)	Signed	Date	Work Done (Item No.)	Signed
1-6-23	1-2-3	J.D.			
1-7-23	1-2	J.D.			
1-8-23	1-2-4-5-6	P. K.			

## Electrical Equipment





### Beware of Electricity

- Do not attempt to install, troubleshoot, maintain, repair, or replace electrical equipment, panels, controls, wiring, or circuits unless
  - You know what you are doing
  - You are qualified
  - You are authorized



## Fundamentals of Electricity





### Volts

- Also known as electromotive force (EMF)
- The electrical pressure available to cause a flow of current (amperage) when a circuit is closed
- Voltage (E) is the force that is necessary to push electricity or electric current through a wire
- Two types:
  - Direct current (DC)
  - Alternating current (AC)

### Direct Current (DC)

- Flow in one direction and is essentially free from pulsation
- Used exclusively in automotive equipment, certain types of welding equipment, and a variety of portable equipment
- Found in various voltages
  - 6, 12, 24, 48, and 110 volts
- All batteries are DC



**DIRECT CURRENT (DC)**

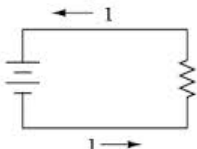

### Alternating Current (AC)

- Voltage and current periodically change direction and amplitude
- Current goes from zero to maximum strength, back to zero, and to the same strength in the opposite direction
- Hertz describes the frequency of cycles completed per second
- Classified as
  - Single phase
  - Two phase
  - Three phase or polyphase

ALTERNATING CURRENT (AC)



### Alternating Current – Single Phase

- Found in lighting systems, small pump motors, various portable tools, and throughout homes
- Usually 120 volts and sometimes 240 volts
- Only one phase of power is supplied to the main electrical panel

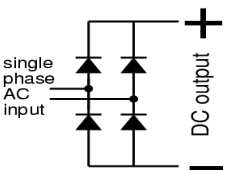

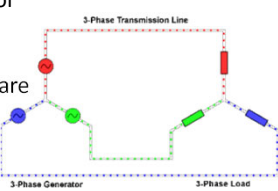

### Alternating Current – Three Phase

- Generally used with motors and transformers
- Usually is 208, 220, 240 volts, or 440, 460, 480, and 550 volts
- Used when high-power requirements or larger motors are used
- Efficiency is higher and less maintenance is required
- Generally, all motors with > 2 HP are three phase

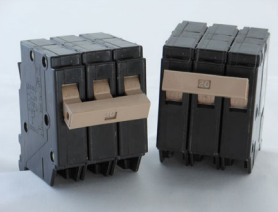

### Alternating Current – Circuit Breakers

- Used to protect electric circuits from overloads
- Metal conductors that de-energize the main circuit is overheated by too much current passing through

## Amps

- The measurement of current or electron flow and is an indication of work being done or "how hard the electricity is working"
- The practical unit of electrical current

## Watts (W) and Kilowatts(kW)

- The units of measurement of the rate at which power is being used or generated
- In DC circuits, watts equal the voltage times the current  
Watts = (volts)(amps)
- In AC polyphase circuits, you have to include the power factor and the  $\sqrt{3}$   
Watts = (volts)(amps)(power factor)(1.73)
- Power factor is the ratio of actual power passing through a circuit to the apparent power
  - Usually somewhere near 0.9

## Conductors and Insulators

- Conductor - a material that allows the flow of electric current e.g. copper
- Insulator - a material that will not allow the flow of electricity e.g. rubber
  - Insulation commonly used to prevent the loss of electrical flow by two conductors coming into contact with each other

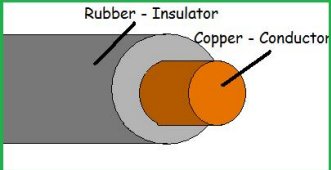

The diagram shows a cross-section of a wire. It consists of a central orange cylinder labeled 'Copper - Conductor' surrounded by a grey ring labeled 'Rubber - Insulator'.

## Electricity Simplified

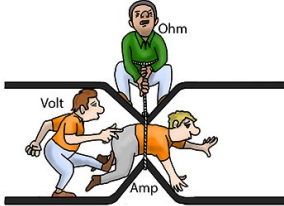

The cartoon shows three people on a set of parallel black lines representing electrical wires. A person labeled 'Ohm' is sitting on the top wire. Two people labeled 'Volt' and 'Amp' are running between the wires, representing the flow of electricity.

Quantity	Symbol	Unit of Measurement	Unit Abbreviation
Current	I	Ampere (Amp)	A
Voltage	V or E	Volt	V
Resistance	R	Ohm	$\Omega$

## Tools, Meters and Testers



The Fleming Training Center logo features a water drop with a recycling symbol and the text 'Your Partner in Clean Water'. The TN Department of Environment & Conservation logo features a red square with 'TN' and the text 'Department of Environment & Conservation'.

## Voltage Testing

- Multimeter used for checking voltage
- Use meter that has sufficient range to measure voltage you would expect to find
- Tells if AC or DC and intensity or voltage
- Used to test for open circuits, blown fuses, single phasing of motors, grounds, etc.



The image shows a yellow digital multimeter with a black display showing '000'. It has various function buttons and a rotary dial. Two test leads, one red and one black, are plugged into the top of the device.

## Ammeter

- Records the current or “amps” flowing in the circuit
- Two common types:
  - Clamp-on type – used for testing
    - Clamped around a wire supplying a motor
  - In-line type – installed in a panel or piece of equipment
    - Connected in line with the power lead or leads



## Megger

- Used for checking the insulation resistance on motors, feeders, bus bar systems, grounds, and branch circuit wiring
- Connected to a motor terminal at the starter
- Test results show if the insulation is deteriorating or cut
- Three types
  - Crank operated
  - Battery operated
  - Instrument



## Ohmmeters

- Used to measure the resistance in a circuit
- Also called circuit testers
- Electrical circuit must be OFF to use ohmmeter
- Ohmmeter supplies own power



## Equipment Protective Devices



## Fuses

- A protective device having a strip or wire of fusible metal that will melt and break the electrical circuit when subjected to excessive temperature
- Common types:
  - Current-limiting fuses – used to protect power distribution circuits
  - Dual-element fuses – used for motor protection circuits
- Be sure to replace fuses with proper size and type indicated for that circuit

## Fuses



### Circuit Breakers

- A protective device consisting of a switch that opens automatically when the current of the voltage exceeds or falls below a certain limit
- Can be reset unlike a fuse
- Can be visually inspected to find out if it has been tripped

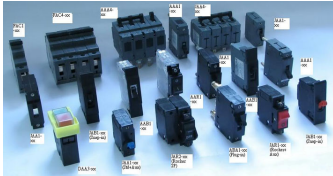

### Overload Relays

- Heater strips open on current rise (overheating) and open the control circuit
  - This opens the power control circuit which de-energizes the start and stops power to the motor
- Also known as heaters or “thermal overloads”
- Range from 100-110% of the motor nameplate ratings
- Should never exceed 125% of the motor rating
- Never increase the rating of the overload relay
  - Find the problem that is causing it to trip and repair it
- Ground – an electrical connection to earth or a large conductor that is at the earth’s potential or neutral voltage

### Overload Relays



### Auxiliary Electrical Power

- Standby power generation – three types
  - Engine driven generator
  - Batteries
  - Alternate power source
- Emergency lighting
- Batteries



### Compressors

- A device used to increase the pressure of air or gas
- Consists of a suction pipe with a filter and a discharge pipe that connects to an air receiver
- Can be simple diaphragm type or complex rotary, piston, or sliding vane type

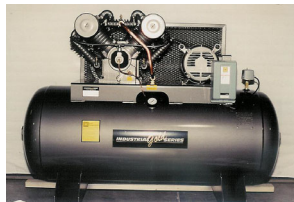

### Compressor Maintenance

- Inspect the suction filter of the compressor monthly
  - Clean or replace filter every 3-6 months
- Lubrication must be inspected daily
  - Oil should be replaced every 3 months
- Cylinder or casing fins should be cleaned weekly
- Inspect unloader
  - If not working properly, compressor will not start, stall, or burn off belts if belt driven
- Test the safety valves weekly

## Compressor Maintenance

- Drain the condensate from air receiver daily
  - If has automatic drain, inspect periodically
- Inspect belt tension on compressor
  - Should be able to press the belt down, in the center, with your hand approximately ¼ inch
- Examine operating controls
  - Make sure compressor is starting and stopping at the proper settings
- Ensure portable compressors have oil in tool oiler reservoir
- Clean thoroughly each month

## Valves



## Gate Valves

- Basic parts: operator (handle), shaft packing assembly, bonnet, valve body with seats, stem, and disc
- Valve disc is raised/lowered by a threaded shaft
- Disc is screwed down until it wedges itself between two machined valve seats
- Not used to control flows
- Either rising stem or non-rising stem type

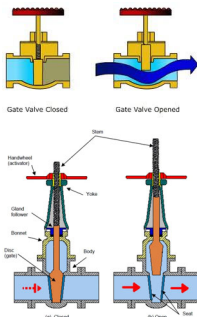

## Gate Valves – O & M

- 1. Open valve fully
- 2. Operate all large valves at least yearly to ensure proper operation
- 3. Inspect valve stem packing for leaks
- 4. If the valve has a rising stem, keep stem threads clean and lubricated
- 5. Close valves slowly in pressure lines to prevent water hammer
- 6. If a valve will not close by using the handwheel, check for the cause; Using a “cheater” bar will only aggravate the problem

## Gate Valves - Maintenance

Frequency	Service
Annually	<b>Replace packing:</b> Remove all old packing from stuffing box. Insert new split ring packing while staggering the ring splits.
Semi-annually	<b>Operate valve:</b> Operate inactive gate valves to prevent sticking
Annually	<b>Lubricate gearing:</b> Lubricate gate valves as recommended by manufacturer
Semi-annually	<b>Lubricate rising stem threads:</b> Clean threads on rising stem gate valves and lubricate with grease
Annually	<b>Reface leaky gate valve seats:</b> Remove bonnet and clean examine disc body thoroughly. Check and service all parts of valve completely. Remove all old packing a clean out stifing box. Do not salvage old gasket. After cleaning and examining all parts, determine whether valve can be repaired or must be replaced. Test repaired valve before putting back in line.

## Globe Valves

- Use a circular disc to make a flat surface contact with a ground-fitted valve seat
- Internal design enables valve to be used in a controlling /throttling mode
- Can be of rising or nonrising stem type
- O & M similar to gate valve

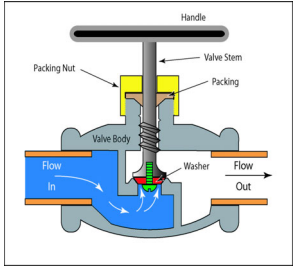

### Ball Valves

- A valve consisting of a ball resting in a cylindrical seat
- A hole is bored through the ball to allow water to flow when the valve is open
- When the valve is rotated 90°, the valve is closed
- Should be operated fully open or fully closed
  - Throttling can lead to damage to the seal

### Eccentric Valves

- Uses a cam shaped plug to match an eccentric valve seat
- As the valve is closed, the plug throttles the flow yet maintains a smooth flow rate
- Excellent for controlling the flows of slurries and sludges

### Butterfly Valves

- Used primarily as a control valve
- Uses a machined disc that can be opened to 90° to allow full flow through valve
- Closed valve is forced against the continuous rubber seat

### Check Valves

- Allows water to flow in only one direction
- Three types:
  - Swing check – a movable disc (clapper) rests at a right angle to the flow and seats against a ground seat
  - Wafer check – a circular disc that hinges in the center of the disc. Flow collapses the disc and flow stoppage allows the disc to return to its circular form
  - Lift check – uses a vertical lift disc or ball. Flow lifts the disc/ball and allows water to flow through.
    - Foot valves are nearly always vertical lift valves

### Check Valves

Swing Check Valve      Lift Check Valve      Wafer Check Valve

### Check Valves - Maintenance

Frequency	Service
Annually	<b>Inspect disc facing:</b> Open valves to observe condition of facing on swing check valves
Annually	<b>Check pin wear:</b> Check pin wear on balanced check valve, since disc must be accurately positioned in seat to prevent leakage

## Pump and Motor Facts

### ***Pump Facts***

High-service pump – discharges water under pressure to the distribution system.

Booster pump – used to increase pressure in the distribution system and to fill elevated storage tanks.

Impeller or centrifugal pump used to move water.

Likely causes of vibration in an existing pump/motor installation:

1. bad bearings
2. imbalance of rotating elements
3. misalignment from shifts in underlying foundation

Pump and motor should be tested and complete test results recorded as a baseline for the measurement of performance within the first 30 days of operations.

Calipers and thickness gauges can be used to check alignment on flexible couplings.

### ***Packing/Seals Facts***

If new packing leaks, stop the motor and repack the pump.

Pumps need new packing when the gland or follower is pulled all the way down.

The packing around the shaft should be tightened just enough to allow an occasional drop of liquid for cooling.

Joints of packing should be staggered at least 90°.

Mechanical seals consist of a rotating ring and stationary element.

The operating temperature on a mechanical seal should never exceed 160°F or 71°C.

### ***Motor Facts***

Motors pull the most current on start up.

In order to prevent damage, turn the circuit off immediately if the fuse on one of the legs of a three-phase circuit blows.

An electric motor changes electrical energy into mechanical energy.



Power factors on motors can be improved by:

1. changing the motor loading
2. changing the motor type
3. using capacitors

Routing cleaning of pump motors includes:

1. checking alignment and balance
2. checking brushes
3. removing dirt and moisture
4. removal of obstructions that prevent air circulation

Cool air extends the useful life of motors.

A motor (electrical or internal combustion) used to drive a pump is called a prime mover.

The speed at which the magnetic field rotates is called the motor synchronous speed and is expressed in rpm.

If a variable speed belt drive is not to be used for 30 days or more, shift the unit to minimum speed setting.

Emory cloth should not be used on electric motor components because it is electrically conductive and may contaminate parts.

Ohmmeters used to test a fuse in a motor starter circuit.

The most likely cause of a three-phase motor not coming to speed after starting – the motor has lost power to one or more phases.

### ***Transformer Facts***

Transformers are used to convert high voltage to low voltage.

High voltage is 440 volts or higher.

Standby engines should be run weekly to ensure that it is working properly.

Relays are used to protect electric motors.

## Pump Maintenance Record Sheet

Facility ID \_\_\_\_\_

Equipment \_\_\_\_\_ Manufacturer \_\_\_\_\_

Model No. \_\_\_\_\_ Serial No. \_\_\_\_\_

HP \_\_\_\_\_ Voltage \_\_\_\_\_ Amps \_\_\_\_\_ RPM \_\_\_\_\_

Frame \_\_\_\_\_ GPM \_\_\_\_\_ TDH \_\_\_\_\_ ft.

Impeller Size \_\_\_\_\_

Suction Pressure \_\_\_\_\_ Discharge Pressure \_\_\_\_\_

Pump Type \_\_\_\_\_

Additional Information:

---

---

---

---

## Pump Vocabulary

1. Velocity Pump – the general class of pumps that use a rapidly turning impeller to impart kinetic energy or velocity to fluids. The pump casing then converts this velocity head, in part, to pressure head. Also known as kinetic pumps.
2. Centrifugal Pumps – a pump consisting of an impeller on a rotating shaft enclosed by a casing having suction and discharge connections. The spinning impeller throws water outward at high velocity, and the casing shape converts this velocity to pressure.
3. Vertical Turbine Pump – a centrifugal pump, commonly of the multistage, diffuser type, in which the pump shaft is mounted vertically.
4. Submersible Pump – a vertical-turbine pump with the motor placed below the impellers. The motor is designed to be submersed in water.
5. Jet Pump – a device that pumps fluid by converting the energy of a high-pressure fluid into that of a high-velocity fluid.
6. Axial-Flow Pump – a pump in which a propeller-like impeller forces water out in the direction parallel to the shaft. Also called a propeller pump.
7. Radial-Flow Pump – a pump that moves water by centrifugal force, spinning the water radially outward from the center of the impeller.
8. Mixed-Flow Pump – a pump that imparts both radial and axial flow to the water.
9. Single-Suction Pump – a centrifugal pump in which the water enters from only one side of the impeller. Also called an end-suction pump.
10. Double-Suction Pump – a centrifugal pump in which the water enters from both sides of the impeller. Also called a split-case pump.
11. Closed-Coupled Pump – a pump assembly where the impeller is mounted on the shaft of the motor that drives the pump.
12. Frame-Mounted Pump – a centrifugal pump in which the pump shaft is connected to the motor shaft with a coupling.
13. Positive Displacement Pump – a pump that delivers a precise volume of liquid for each stroke of the piston or rotation of the shaft.
14. Reciprocating Pump – a type of positive-displacement pump consisting of a closed cylinder containing a piston or plunger to draw liquid into the cylinder through an inlet valve and forces it out through an outlet valve.
15. Rotary Pump – a type of positive-displacement pump consisting of elements resembling gears that rotate in a close-fitting pump case. The rotation of these elements alternately draws in and discharges the water being pumped.

16. Prime Mover – a source of power, such as an internal combustion engine or an electric motor, designed to supply force and motion to drive machinery, such as a pump.
17. Packing – rings of graphite-impregnated cotton, flax, or synthetic materials, used to control leakage along a valve stem or a pump shaft.
18. Packing Gland – a follower ring that compressed the packing in the stuffing box.
19. Wear Rings – rings made of brass or bronze placed on the impeller and/or casing of a centrifugal pump to control the amount of water that is allowed to leak from the discharge to the suction side of the pump.
20. Lantern Ring – a perforated ring placed around the pump shaft in the stuffing box. Water from the pump discharge is piped to this ring. The water forms a liquid seal around the shaft and lubricates the packing.
21. Mechanical Seal – a seal placed on the pump shaft to prevent water from leaking from the pump along the shaft; the seal also prevents air from entering the pump.
22. Stuffing Box – a portion of the pump casing through which the shaft extends and in which packing or a mechanical seal is placed to prevent leakage.
23. Impeller – the rotating set of vanes that forces water through the pump.
24. Casing – the enclosure surrounding a pump impeller, into which the suction and discharge ports are machined.
25. Volute – the expanding section of pump casing (in a volute centrifugal pump), which converts velocity head to pressure head.
26. Foot Valve – a check valve placed in the bottom of the suction pipe of a pump, which opens to allow water to enter the suction pipe but closes to prevent water from passing out of it at the bottom end. Keeps prime.
27. Bearing – anti-friction device used to support and guide a pump and motor shafts.
28. Diffuser Vanes – vanes installed within a pump casing on diffuser centrifugal pumps to change velocity head to pressure head.
29. Water Hammer – the potentially damaging slam that occurs in a pipe when a sudden change in water velocity (usually as a result of too-rapidly starting a pump or operating a valve) creates a great increase in water pressure.
30. Suction Lift – the condition existing when the source of water supply is below the centerline of the pump.
31. Cavitation – a condition that can occur when pumps are run too fast or water is forced to change direction quickly. A partial vacuum forms near the pipe wall or impeller blade causing potentially rapid pitting of the metal.

## Pump and Motor Review Questions

- 1) Leakage of water around the packing on a centrifugal pump is important because it acts as a(n):
  - a) Adhesive
  - b) Lubricant
  - c) Absorbent
  - d) Backflow preventer
  
- 2) What is the purpose of wear rings in a pump?
  - a) Hold the shaft in place
  - b) Hold the impeller in place
  - c) Control amount of water leaking from discharge to suction side
  - d) Prevent oil from getting into the casing of the pump
  
- 3) Which of the following does a lantern ring accomplish?
  - a) Lubricates the packing
  - b) Helps keep air from entering the pump
  - c) Both (a.) and (b.)
  
- 4) Closed, open and semiopen are types of what pump part?
  - a) Impeller
  - b) Shaft sleeve
  - c) Casing
  - d) Coupling
  
- 5) When tightening the packing on a centrifugal pump, which of the following applies?
  - a) Tighten hand tight, never use a wrench
  - b) Tighten to 20 foot pounds of pressure
  - c) Tighten slowly, over a period of several hours
  - d) Tighten until no leakage can be seen from the shaft
  
- 6) Excessive vibrations in a pump can be caused by:
  - a) Bearing failure
  - b) Damage to the impeller
  - c) Misalignment of the pump shaft and motor
  - d) All of the above
  
- 7) What component can be installed on a pump to hold the prime?
  - a) Toe valve
  - b) Foot valve
  - c) Prime valve
  - d) Casing valve

- 8) The operating temperature of a mechanical seal should not exceed:
- 140°F
  - 150°F
  - 160°F
  - 170°F
- 9) What is the term for the condition where small bubbles of vapor form and explode against the impeller, causing a pinging sound?
- Corrosion
  - Cavitation
  - Aeration
  - Combustion
- 10) The first thing that should be done before any work is begun on a pump or electrical motor is:
- Notify the state
  - Put on safety goggles
  - Lock out the power source and tag it
  - Have a competent person to supervise the work
- 11) Under what operating condition do electric motors pull the most current?
- At start up
  - At full operating speed
  - At shut down
  - When locked out
- 12) Positive displacement pumps are rarely used for water distribution because:
- They require too much maintenance
  - They are no longer manufactured
  - They require constant observation
  - Centrifugal pumps are much more efficient
- 13) Another name for double-suction pump is
- Double-jet pump
  - Reciprocating pump
  - Horizontal split-case pump
  - Double-displacement pump
- 14) As the impeller on a pump becomes worn, the pump efficiency will:
- Decrease
  - Increase
  - Stay the same

## Answers:

- |      |       |       |
|------|-------|-------|
| 1) B | 6) D  | 11) A |
| 2) C | 7) B  | 12) D |
| 3) C | 8) C  | 13) C |
| 4) A | 9) B  | 14) A |
| 5) C | 10) C |       |

**Section 12**

**Sampling & Water Analysis**



## Water Quality, Analysis and Sampling in Distribution System

### Objectives

- Need for monitoring water quality
- Identify types of samples
- Collect proper samples
  - Preserving and storing techniques
- Perform lab/field tests

### Water Quality Monitoring

- Monitored to ensure safety and integrity
- Monitored to meet state and federal requirements
- Water quality can degrade in distribution system due to contamination or growth of organisms

### Prevent Quality Degradation

- Treated water is disinfected, not sterilized
- Disinfection kills or inactivates harmful organisms (pathogens)
- Organisms can grow in distribution system if conditions are right
- To prevent growth of organisms:
  - Keep chlorine residual up
  - Keep excess nutrients out
  - Prevent stagnation
  - Prevent cross-connections

### Water Quality Analysis

- The first step in water quality analysis is collecting samples which accurately represent the water
  - Representative sample - sample which contains basically the same constituents as the body of water from which it was taken
  - Improper sampling is one of the most common causes errors in water quality analysis
- All chemical analysis records must be kept for 10 years

### Types of Samples

- ❶ **Grab sample**
  - Single volume of water
  - Representative of water quality at exact time and place of sampling
  - Coliform bacteria, residual chlorine, temperature, pH, dissolved gases
- ❷ **Composite samples**
  - Representative of average water quality of location over a period of time
  - Series of grab samples mixed together
  - Determines average concentration
  - Not suitable for all tests



## Composite Samples

- Time composite - equal volumes at different times
- Flow-proportional composite - volume varies depending on flow rate

## Sample Volume and Storage

- Volume depends on test requirements
- Use proper sampling container
- Follow recommended holding times and preservation methods
  - if bottle already has preservative or dechlorinator in it, don't over fill or rinse out
- ✓ If you have questions regarding volume, container or holding times, check *Standard Methods* or contact the lab if you have an outside lab do your analysis

## Sample Labeling

- Specific location (address)
- Date and time sampled
- Chlorine residual
- pH and temperature (if needed)
- Sample number or identification
- Name or initials of person taking sample

## Sample Labeling

Site 196 E. Main Street Billieville, TN  
 Date / Time August 15, 2023 8:15 AM  
 Code B16089  
 Sampled by Billy Joe Smith  
 Comments pH < 2 with H<sub>2</sub>SO<sub>4</sub> and stored at 4°C  
Free residual chlorine = 2.1 mg/L

## Distribution Sampling Points

- Distribution sampling is best indicator of system water quality
- Water quality changes in distribution system can be caused by:
  - Corrosion - increase in color, turbidity, taste & odor
  - Microbiological growth - slime
  - Cross-connections



## Distribution Samples



- Determine water quality at customers' taps
- Most common tests are chlorine residual and coliform bacteria
- Number of samples depends on population served

## Bacteriological Samples



- Only approved containers should be used to collect sample
  - should have sodium thiosulfate in them to dechlorinate the water

## Bacteriological Samples

- Bacteriological samples should never be taken from a hose
- Only collect samples from approved faucets
  - Do not collect from spigots with internal threads
- Don't collect samples from swivel faucets
- Only use cold water tap
- Front yard faucets on homes with short service lines

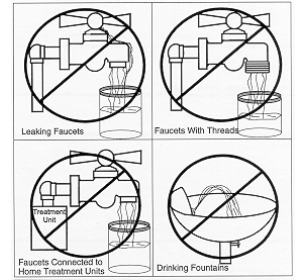

## Bacteriological Samples

- Do not flame faucet with torch
  - Disinfect with chlorine or alcohol
- Turn on faucet to steady flow and flush service line (2 - 5 min)
  - getting water from main line
- Fill bottle to proper level (100 mL  $\pm$  2 mL)
- If container has screw-on lid, do not set it down on ground or put in your pocket
- Label bottle with pertinent information
- Test as soon as possible - within 30 hours

## Microbiological Indicator Organism

- Always present in contaminated water
- Always absent when no contamination
- Survives longer in water than other pathogens
- Is easily identified
- Water treatment indicator organism
  - Coliform group (total coliforms)

## Bacteriological Samples

- The MCL for coliform bacteria is based on presence or absence
- Finished and distributed water should be 0 (absent)
- Must keep results for 5 years



## pH

- One of the most important and frequently used tests in water chemistry
- A measure of the intensity of the acidic or alkaline character of a solution
- Logarithmic scale of ionic activity 0 to 14 s.u. (standard units)
- pH values cannot be averaged

## pH Measurement



- pH is typically measured with a meter and probe
- This is an electrochemical method of analysis

## pH Theory

- pH is defined as the negative log of the molar hydrogen ion concentration in aqueous solution
- pH runs from a scale of 0-14 **pH = -log [H<sup>+</sup>]**
  - $\text{H}_2\text{O} \rightarrow \text{H}^+ + \text{OH}^-$
  - $\text{H}^+ = 10^{-7} \text{ mol/L}$
  - $\text{OH}^- = \frac{10^{-7} \text{ mol/L}}{10^{14} \text{ mol/L}}$

## pH Theory

- Acid
    - increases the hydrogen ion (H<sup>+</sup>) concentration in a solution
  - Base
    - increases the hydroxide ion (OH<sup>-</sup>) concentration in a solution
- 
- ↑ H<sup>+</sup> ion concentration      ↓ OH<sup>-</sup> ion concentration  
 ↓ OH<sup>-</sup> ion concentration      ↑ H<sup>+</sup> ion concentration

## pH Scale

- pH is a negative logarithmic function
- Each decrease in pH unit = 10X increase in acidity
  - Solution at pH 4 is 10X more acidic than solution at pH 5
  - Solution at pH 4 is 100X more acidic than pH 6 solution
  - pH 7: H<sup>+</sup> = 10<sup>-7</sup> and OH<sup>-</sup> = 10<sup>-7</sup>
  - pH 4: H<sup>+</sup> = 10<sup>-4</sup> and OH<sup>-</sup> = 10<sup>-10</sup>

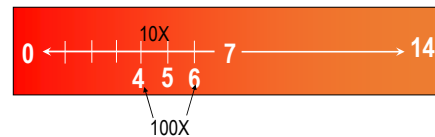

## Turbidity

- Physical cloudiness of water
- Due to suspended silt, finely divided organic and inorganic matter, and algae
- Nephelometric method measures scattered light (unit: NTU)
- SDWA stipulates specific monitoring requirements
- Measure samples ASAP; keep sample tubes clean and scratch free inside and out
- Records must be kept for 5 years

## Turbidimeter

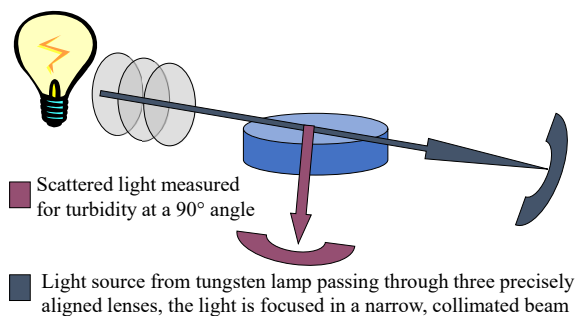

## Measuring Chlorine Residual

- Free chlorine residual must be tested and recorded when bacteriological samples are collected
- Analysis should be performed as soon as possible, exposure to sunlight or agitation of the sample will cause a reduction in the chlorine residual
  - Sample holding time = 15 minutes
- Must maintain a free residual of 0.2 mg/L throughout entire distribution system
  - Chlorine residual must not be less than 0.2 mg/L in more than 5% of samples each month for any two consecutive months

## Measuring Chlorine Residual

- 2 methods:
  - DPD colorimetric
    - method most commonly used
    - Match color of sample to a standard
    - Swirl sample for 20 seconds to mix
    - Within one minute of adding reagent, place it into colorimeter
  - Amperometric titration
    - Titrate sample with phenylarsene oxide solution (PAO) until further additions no longer cause deflection on microammeter
    - mL of PAO used is equal to mg/L of free residual
    - **Titration** – process of adding a chemical of known strength drop by drop until a certain endpoint (color change, pH, precipitate, etc) is reached

## Chlorine Residual

- Free chlorine residual
  - That chlorine that is left over after reaching the breakpoint and can be used for disinfection
  - What we typically test for
- Total chlorine residual
  - Includes the free chlorine residual as well as the combined chlorine residual
  - Combined chlorine residual – that chlorine left over after reaching the breakpoint that has combined with ammonia in the water
    - May still be an effective disinfectant

Total Residual = Free residual + Combined residual

## Fluoride

- Added to drinking water for the reduction of dental caries (cavities)
- Interferences:
  - Phosphate has positive interference
  - Aluminum has negative interference
- Primary MCL = 4.0 mg/L
- Secondary MCL = 2.0 mg/L
- State of Tennessee recommends 0.7 mg/L

## Alkalinity

- The ability of a solution to neutralize an acid
- Tested by titrating sample with 0.02 N sulfuric acid
- Two types commonly tested for
  - Phenolphthalein alkalinity
    - Drop pH to endpoint of 8.3 OR
    - Use phenolphthalein color indicator to achieve color change of pink to clear
  - Total alkalinity
    - Drop pH to endpoint of 4.5 OR
    - Use methyl orange or bromcresol green methyl red color indicator to achieve color change of blue/green to pink

## Water Stabilization

- Unstable water can lead to issues in the distribution systems
  - Problems range from excessive customer complaints to increased pumping costs, to replacement of mains due to leaks and breaks
- Corrosion control is also important in protecting consumers from the dangers of excess lead and copper

## Phosphates

- Test for reactive (ortho-phosphates) phosphates if they are added at the water plant for corrosion control
- Polyphosphates work as sequestering agents - tie up iron and manganese to prevent color and taste complaints
- Orthophosphates work well for lead and copper protection

## Polyphosphates

- Polyphosphates work as sequestering agents - tie up iron and manganese to prevent color and taste complaints
  - They also tie up calcium carbonate to prevent excess scale
  - Calcium (from alkalinity) is required as a catalyst
  - If low alkalinity, need a blend of polyphosphate and orthophosphate

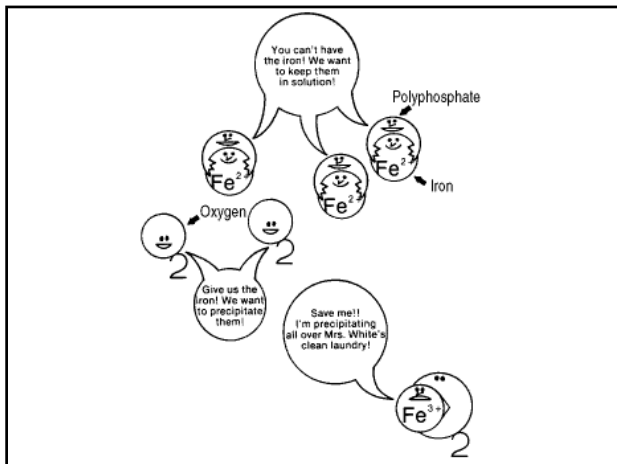

## Orthophosphates

- Orthophosphate coats pipe, polyphosphate sequesters
- Orthophosphates work well for lead and copper protection

## Phosphates



### Color comparator method for field testing

Blue color indicates presence of phosphates

## Lead and Copper Rule

- Established in by EPA in 1991
- All community and non-community water systems must monitor for lead and copper at customers' taps
- If aggressive water is dissolving these metals, system must take action to reduce corrosivity
- Samples must be taken at high risk locations - homes with lead service lines
- Water must sit in lines for at least 6 hours - first draw
- One liter of sample collected from cold water tap in kitchen or bathroom
- Test results must be maintained for 12 years

### Lead and Copper Rule

- Action levels
  - Lead - 0.015 mg/L
  - Copper - 1.3 mg/L
- If action level is exceeded in more than 10% of samples, must take steps to control corrosion:
  - Corrosion control program
  - Source water treatment
  - Public education
  - And/or lead service line replacement

### Disinfection By-products

- Disinfection by-products are produced when organic substances in the water are chlorinated
  - Algae, humic substances, slime buildup in pipeline, etc.
  - Carcinogenic (cancer causing)
- 2 main DBPs of concern
  - THM or TTHM – trihalomethanes
    - MCL = 0.08 mg/L
  - HAA<sub>5</sub> – halo acetic acids
    - MCL = 0.06 mg/L

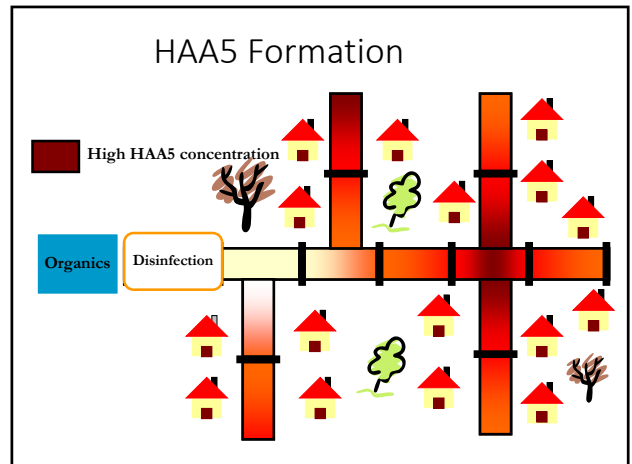
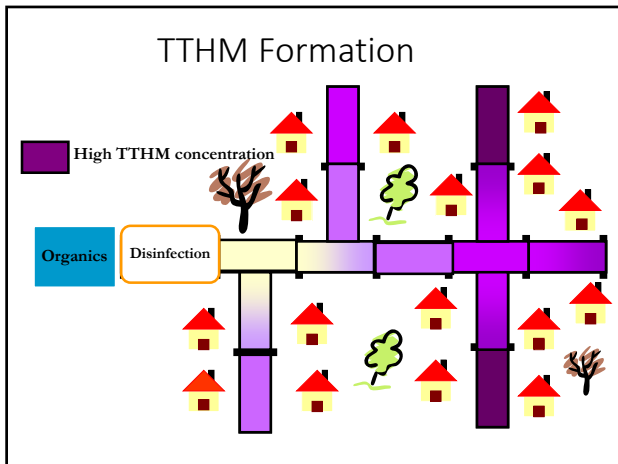

### Other Factors that Influence DBP Formation

Parameter (Increasing)	TTHM	HAA5
TOC	↑	↑
Time	↑	↔
Temperature	↑	↑
Disinfectant Dose	↑	↑
pH	↑	↓
Bromide	↑	↑

### Term Review

- **MCL** - maximum contaminant level
  - Primary regulation, health hazard
- **SMCL** - secondary maximum contaminant level
  - Aesthetics
- **MCLG** - maximum contaminant level goal
  - Level at which no known or anticipated adverse health effect
- **Action level** - lead & copper
  - Level which requires certain action
- **MRDL** - maximum residual disinfectant level
  - The highest level of a disinfectant allowed in drinking water without causing an unacceptable possibility of adverse health effects.

### Total Coliform Monitoring Frequency for Community Water Systems

Population Served	Minimum Number of Samples Per Month
25 to 1,000	1
1,001 to 2,500	2
2,501 to 3,300	3
3,301 to 4,100	4
4,101 to 4,900	5
4,901 to 5,800	6
5,801 to 6,700	7
6,701 to 7,600	8
7,601 to 8,500	9
8,501 to 12,900	10
12,901 to 17,200	15
17,201 to 21,500	20
21,501 to 25,000	25
25,001 to 33,000	30
33,001 to 41,000	40
41,001 to 50,000	50
50,001 to 59,000	60
59,001 to 70,000	70
70,001 to 83,000	80
83,001 to 96,000	90
96,001 to 130,000	100
130,001 to 220,000	120
220,001 to 320,000	150
320,001 to 450,000	180
450,001 to 600,000	210
600,001 to 780,000	240
780,001 to 970,000	270
970,001 to 1,230,000	300
1,230,001 to 1,520,000	330
1,520,001 to 1,850,000	360
1,850,001 to 2,270,000	390
2,270,001 to 3,020,000	420
3,020,001 to 3,960,000	450
3,960,001 or more	480

## Sampling and Analysis Review Questions

- 1 What is the difference between a grab sample and a composite sample?
  
- 2 Why should you never use a composite sample for bacteriological analysis?
  
- 3 List and describe the two types of composite samples.
  
- 4 What types of faucets should be avoided when selecting sampling points?
  
- 5 What is the maximum number of hours a bacteriological sample can be held before testing?
  
- 6 How long should a service line be flushed before sampling?
  
- 7 What is the easiest method to test for chlorine residual in the field?
  
- 8 What information should be recorded on the label of a bacteriological sample?



- 9 What is the indicator organism used in the bacteriological test?
- 10 According to the Lead and Copper Rule, what is the action level for lead?
- 11 According to the Lead and Copper Rule, what is the action level for copper?
- 12 What determines the MCL for total coliforms in drinking water?
- 13 Name three causes of water quality degradation in the distribution system.
- 14 Define the following terms:
- MCL –
  
  
  
  
  
  
  
  
  
  
  - sMCL –
  
  
  
  
  
  
  
  
  
  
  - Action Level –

## Answers

1. Grab sample – single volume collected at a specific place and time  
Composite sample – series of grab samples mixed together, determines average concentration, not suitable for all tests.
2. Must be taken in a sterile container, must be tested within 30 hours, cannot determine where the positive occurred.
3. Time composite – equal volumes at different times  
Flow-proportional composite – volume varies depending on flow rate
4. Leaking faucets, Faucets with home treatment units, Drinking fountains, Swivel faucets
5. 30 hours
6. 2-3 minutes (Standard Methods) or to uniform temperature
7. DPD test kit
8. Location, Date, Time, Chlorine residual, Sample # and type, Collector's name or initials
9. Total coliforms (coliform group)
10. 0.015 mg/L
11. 1.3 mg/L
12. Presence / Absence
13. Corrosion, Microbial growth, Cross-connections
14. MCL – Maximum Contaminant Level – maximum permissible level of a contaminant in drinking water as specified in the Safe Drinking Water Act. For primary regulations, health hazards.  
  
sMCL – Secondary Maximum Contaminant Level – based on aesthetic quality of water, non health hazard  
  
Action Level – Level of a contaminant which, if exceeded, requires specific action(s) to reduce risk of adverse health effects.

## **Section 13**

### **Regulations &**

### **Design Criteria**

The Community Public Water Systems Design Criteria document  
can be found in its entirety at:

[https://www.tn.gov/content/dam/tn/environment/water/documents/  
wr\\_wq\\_dw-community-water-system-design-criteria.pdf](https://www.tn.gov/content/dam/tn/environment/water/documents/wr_wq_dw-community-water-system-design-criteria.pdf)

The Rules of Tennessee Department of Environment and  
Conservation Division of Water Resources  
Chapter 0400-45-01 Public Water Systems  
document can be found in its entirety at:

[https://publications.tnsosfiles.com/rules/0400/0400-45/0400-45-  
01.20190217.pdf](https://publications.tnsosfiles.com/rules/0400/0400-45/0400-45-01.20190217.pdf)

Record Category	Time frame required to keep records	Source
<b>Microbiological Records</b>		0400-45-01-.20(1)(a)
Routine distribution	5 years	
Line repair records	5 years	0400-45-01-.17(8)(a)
New line records	5 years	
Bacteriological sampling plan	Keep updated, at least every 3 years	
<b>Chemical Analysis</b>		0400-45-01-.20(1)(a)
Inorganics/ secondaries	10 years	
SOC's	10 years	
VOC's	10 years	
THM's and HAA5's	10 years	
Radionuclides	10 years	
Lead and copper	12 years	0400-45-01-.33(12)
<b>Miscellaneous</b>		
Action regarding violations	3 years	0400-45-01-.20(1)(b)
Certified Letters to Fire Departments regarding Class C hydrants	5 years	0400-45-01-.17(18)
Complaint file	5 years	0400-45-01-.20(1)(h)
Consumer Confidence Reports	3 years	0400-45-01-.35(h)
Cross connection plans and inspection records	5 years	0400-45-01-.20(1)(h)
Daily worksheets, strip charts, shift logs	5 years	0400-45-01-.20(1)(g)
Disinfection Profile	10 years	
Disinfection SOP	Keep updated	
Distribution map	Keep updated, submit copy to DWS every 5 years	0400-45-01-.17(15)
Distribution SOP	Keep updated	
Emergency Operation Plan	Keep updated	0400-45-01-.34(4)(a)
Facility Maintenance Records	5 years	0400-45-01-.20(1)(h)
Flushing records	Survey to survey or 3 years	0400-45-01-.17(10)
MOR's	5 years	
MSDS	At least 30 years	29 CFR 1910.1020
New tap records	Survey to survey or 3 years	0400-45-01-.17(32)
Notice of Construction	Survey to survey or 3 years	
Plant SOP	Keep updated	
Public Notices	3 years	0400-45-01-.20(i)
Sanitary surveys	10 years	
SDS	At least 30 years	29 CFR 1910.1020
Storage Tank Inspection Records	5 years	0400-45-01-.17(33), 0400-45-01-.20(1)(h)
Tank maintenance records	Life of tank	0400-45-01-.17(33)
Turbidity analysis: daily worksheets, calibration data and strip charts	5 years	0400-45-01-.20(1)(f)
Variations or Exemptions	5 years	0400-45-01-.20(1)(d)

**RULES  
OF  
THE TENNESSEE DEPARTMENT OF ENVIRONMENT AND CONSERVATION  
BOARD OF WATER AND WASTEWATER OPERATOR CERTIFICATION**

**CHAPTER 0400-49-01  
RULES GOVERNING WATER AND WASTEWATER OPERATOR CERTIFICATION**

**TABLE OF CONTENTS**

0400-49-01-.01	Application for Certificate	0400-49-01-.09	Classifications and Qualifications of Wastewater Treatment Plant Operators and Wastewater Collection System Operators
0400-49-01-.02	Examinations	0400-49-01-.10	Continuing Education
0400-49-01-.03	Fees	0400-49-01-.11	Summary Suspension and Revocation of Certificate
0400-49-01-.04	General	0400-49-01-.12	Civil Penalties
0400-49-01-.05	Definitions		
0400-49-01-.06	Classification of Water Treatment Plants and Water Distribution Systems		
0400-49-01-.07	Classifications and Qualifications of Water Treatment Plant Operators and Water Distribution System Operators		
0400-49-01-.08	Classification of Wastewater Treatment Plants and Wastewater Collection Systems		

**0400-49-01-.01 APPLICATION FOR CERTIFICATE.**

- (1) Application for certification by examination.
- (a) A separate application for each certification shall be made on an original form approved by the Board for that purpose and available upon request from the Secretary of the Board.
- (b) An application for certification must be submitted to the Secretary of the Board and include the following items:
1. A sworn application signed by the applicant.
  2. Payment of a non-refundable \$100 fee for each application for examination.
  3. A copy of any verifying document in support of an application must be submitted with the application unless the applicant has previously provided such documentation to the Secretary of the Board. This includes, but is not limited to, proof of high school education or equivalent of the applicant. College transcripts, if needed to document experience credit, must be submitted directly from the college and/or university to the Secretary to the Board. Credit for enrollment in special training courses and programs will only be granted to an applicant upon verification that he/she satisfactorily completed all course or program requirements. If training credit is requested, a copy of a course attendance card, a class roster, or a certificate of completion must be submitted to the Secretary. Verification of work experience must be provided in a written document signed by a certified operator of a similar or higher classification, familiar with the applicant's work experience. However, if no such person is available, it may be documented by a person in authority with the system. The Board may exempt applicants from the verification of work experience requirement where there are unusual circumstances.
- (c) A complete application must be received by the Secretary sixty (60) days or more in advance of the scheduled examination date for consideration. Applications received

(Rule 0400-49-01-.02, continued)

- (5) An applicant shall be notified in writing whether his/her examination score was satisfactory for the issuance of a certificate.
- (6) An applicant who fails to achieve a satisfactory score may reapply for the next examination by submitting an abbreviated application for examination with fees, but he/she shall not be eligible to take another examination for the particular operator classification which he/she failed until five months have elapsed from the date that examination was taken.
- (7) All examinations shall be administered by the Board or its authorized representatives who are empowered to maintain the integrity of all examinations.
- (8)
  - (a) An applicant shall be guilty of cheating upon a written examination who does an act including, but not limited to, the following:
    1. violates paragraph (2) of this rule; or
    2. without express authorization from examination officials,
      - (i) removes examination materials furnished by the Board or the written examination itself, in whole or in part, from the examination room, or
      - (ii) aids another applicant in answering examination questions during a written examination; or
    3. violates the examination rules.
  - (b) Upon a determination by the Commissioner that an applicant is guilty of cheating upon a written examination for a particular operator classification, the applicant shall not be issued an initial certificate of competency for that classification.
  - (c) An applicant shall be ineligible to again apply for certification in that same operator classification for one year from the date the determination of cheating becomes final.
- (9) Required training.
  - (a) Any person seeking to apply to sit for a Grade III or Grade IV examination who failed to achieve a satisfactory score on two previous examinations for the same operator classification for which the person is seeking to apply shall complete 30 hours of Board-sanctioned comprehensive training before the Board will consider the application.
  - (b) A person seeking to apply to sit for a Grade I or Grade II examination who failed to achieve a satisfactory score on two previous examinations for the same operator classification for which the person is seeking to apply shall complete 18 hours of Board-sanctioned comprehensive training before the Board will consider the application.
  - (c) A person seeking to apply to sit for a Small Water Systems or a Biological/Natural Systems examination who failed to achieve a satisfactory score on two previous examinations for the same operator classification for which the person is seeking to apply shall complete 18 hours of Board-sanctioned comprehensive training before the Board will consider the application.

(Rule 0400-49-01-.02, continued)

**Authority:** T.C.A. §§ 4-5-201, et seq. and 68-221-901, et seq. **Administrative History:** Original rule filed May 21, 2014; effective August 19, 2014. Rule renumbered from 1200-05-03. Amendments filed January 18, 2017; effective April 18, 2017. Amendments filed April 12, 2021; effective July 11, 2021.

**0400-49-01-.03 FEES.**

(1) Fees for Certification

(a) Fees for certification shall be required of each applicant and paid in advance as follows:

1. Application fee for each operator examination or reciprocity request applied for..... \$100
2. Missed examination fee ..... \$50
3. Discount annual renewal fee for each operator certificate:  
(Payment prior to February 1) ..... \$50
4. Standard annual renewal fee for each operator certificate:  
(Payment from February 1 through June 30) ..... \$100

(b) No application fee will be returned.

(c) Upon payment of an application fee and approval by the Board, an applicant may take any one scheduled examination during the following 12 months. If an applicant chooses not to take or fails to appear for the first examination offered after receiving approval, the applicant must reapply on a form approved by the Board and submit the missed examination fee to be scheduled for a subsequent exam within the established time. The reapplication must occur 60 days in advance of the examination he/she wishes to take. If an applicant does not take the examination within 12 months of the Board's approval, he/she must reapply by submitting a new application with fees in order to be considered to take a subsequent examination.

(d) Each year a certified operator shall submit to the Board for the following year a completed certificate renewal application and a fee for the renewal of each operator certificate he/she possesses. Applications received prior to February 1 of each year shall be subject to discount renewal fees. Applications received February 1 through June 30 of each year shall be subject to standard renewal fees. Any person failing to meet the June 30 deadline may, within 90 days of the deadline, request that the Board grant a variance. The Board may grant a variance when the delay was caused by extenuating circumstances. A completed certificate renewal application or appropriate annual renewal fee for an expired certificate not received by the Board by June 30 shall preclude the recertification of the operator in his/her expired classification until he/she shall have fulfilled all the requirements for the issuance of an initial certificate in that classification, including the satisfactory completion of a written examination. When an operator classification is upgraded, the certificate he/she was upgraded from becomes void; and no additional fee payment is necessary until renewal.

(2) Reserved.

(3) Fees for Cross Connection Control Testing Application

(a) Fees for Cross Connection Control Testing Application shall be required of each person and paid in advance as follows:

(Rule 0400-49-01-.03, continued)

1. Application fee for a Cross Connection Control Basic Test (Department employees who assist with cross connection control training or testing are exempt)..... \$60
  2. Application fee for Cross Connection Control Renewal Test (Department employees who assist with cross connection control training or testing are exempt)..... \$60
- (b) Application fees are not refundable or transferable.
- (c) The application for testing conducted by the Department must be received a minimum of thirty (30) days in advance of the test he/she wishes to take, however, applications from private institutions may be received the day the test materials are submitted to the Fleming Training Center.
- (d) Prior to sitting for a test, an applicant must present proof of completion of training accepted by the Department for the appropriate test. Basic training may be accepted by the Department if it has a minimum class length of 480 minutes (300 minutes minimum in classroom), including but not limited to the following topics: hydraulic and backflow principles, theory of backflow and cross connection, codes and regulations of a cross connection control program, responsibilities and actions in a cross connection control program and mechanical equipment for cross connection control. Acceptable training must also provide a minimum of one working practice station and test kit for each three students. Renewal training may be accepted by the Department if it has a minimum class length of 300 minutes (180 minutes minimum in classroom) including but not limited to the following topics: hydraulic and backflow principles, theory of backflow and cross connection, codes and regulations of a cross connection control program, responsibilities and actions in a cross connection control program and mechanical equipment for cross connection control. Acceptable training must also provide a minimum of one working station and test kit for each three students.
- (e) An applicant must take the test within twelve (12) months of receipt of the training certificate.

**Authority:** T.C.A. §§ 4-5-201, et seq.; 68-203-101, et seq.; and 68-221-901, et seq. **Administrative History:** Original rule filed May 21, 2014; effective August 19, 2014. Rule renumbered from 1200-05-03. Amendments filed January 18, 2017; effective April 18, 2017. Amendments filed April 12, 2021; effective July 11, 2021.

**0400-49-01-.04 GENERAL.**

- (1) Certification under T.C.A. §§ 68-221-901 et seq., being the “Water and Wastewater Operator Certification Act,” is available to any operator of a water treatment plant, a wastewater treatment plant, a water distribution system, or a wastewater collection system who meets the minimum qualifications of a given classification.
- (2) Each person in direct charge at a water treatment plant, a wastewater treatment plant, a water distribution system, or a wastewater collection system shall hold a certificate in a grade equal to or higher than the grade of the treatment plant, distribution system, or collection system he/she operates. The grade of a facility will be established by the criteria set forth in this chapter of rules.



(Rule 0400-49-01-.04, continued)

- (3) All operating personnel making process control/system integrity decisions about water quality or quantity that affect public health must be certified. A designated certified operator must be available for each operating shift.
- (4) Each water supply system and wastewater system required to have a certified operator shall, no later than the first day of August annually, inform the Board, through its designated agent, the Division of Water Resources, in writing of the name of each person who is a certified operator in direct charge of any water treatment plant, wastewater treatment plant, water distribution system or wastewater collection system it operates. A system shall notify the Division of Water Resources in writing within thirty (30) days of its loss of the services of a certified operator in direct charge.
- (5) A certified operator shall be responsible for keeping the Board Secretary informed of his/her current address.

**Authority:** T.C.A. §§ 4-5-201, et seq. and 68-221-901, et seq. **Administrative History:** Original rule filed May 21, 2014; effective August 19, 2014. Rule renumbered from 1200-05-03.

#### **0400-49-01-.05 DEFINITIONS.**

- (1) "Available" means that a certified operator must be on site or able to be contacted as needed to initiate the appropriate action in a timely manner, based on system size, complexity and the quality of either the source water or the receiving stream.
- (2) "Board" means the board of certification as described in T.C.A. § 68-221-905.
- (3) "Commissioner" and "Department" mean the Commissioner of the Tennessee Department of Environment and Conservation or his/her duly authorized representative.
- (4) "Operating shift" is that period of time during which operator decisions that affect public health are necessary for proper operation of the system.
- (5) "Person in direct charge" as used in these rules means the person or persons expressly designated to be in direct charge and so named in writing to the Board's authorized representative by each water supply system and wastewater system, whose decisions and directions to system personnel control the manipulation of equipment and thereby determine the quality and quantity of the water supplied by a water treatment plant or a water distribution system, or the quality of the effluent from a wastewater treatment plant or the integrity of a wastewater collection system.
- (6) "Process control/system integrity decisions" means decisions regarding the manipulation of equipment, chemicals or processes that determine the quality and quantity of the water supplied by a water treatment plant or a water distribution system, or the quality of the effluent from a wastewater treatment plant or the integrity of a wastewater collection system.
- (7) "Written examination" means an examination taken in either written or electronic format.

**Authority:** T.C.A. §§ 4-5-201, et seq. and 68-221-901, et seq. **Administrative History:** Original rule filed May 21, 2014; effective August 19, 2014. Rule renumbered from 1200-05-03. Amendments filed April 12, 2021; effective July 11, 2021.

(Rule 0400-49-01-.09, continued)

**COLLECTION SYSTEM OPERATORS**

Classification	Experience		Maximum Training or College Classwork Substitution	Maximum Related Work Substitution
	Experience needed with:	HS Education		
Grade II	Gained at a Collection I or II System	12 Months	3 Months	
Grade I	Gained at a Collection I or II System	12 Months	3 Months	

**Authority:** T.C.A. §§ 4-5-201, et seq. and 68-221-901, et seq. **Administrative History:** Original rule filed May 21, 2014; effective August 19, 2014. Rule renumbered from 1200-05-03.

**0400-49-01-.10 CONTINUING EDUCATION.**

- (1) Completion of Continuing Education Requirements. At least once during every continuing education period each certified operator shall satisfactorily complete the required number of continuing education hours approved by the Board for the particular type of certificate he/she holds.
- (2) Continuing Education Period. The continuing education period is three calendar years and shall begin either with the date the certified operator obtained his/her certificate or the date the certified operator last satisfactorily completed the required number of continuing education hours and shall end at the conclusion of the annual continuing education term three calendar years thereafter. An annual continuing education term shall begin each year on October 1 and shall end on September 30 of the following year.
- (3) Failure to Complete Continuing Education Requirements. The failure of an operator to satisfactorily complete the required number of continuing education hours approved by the Board Secretary during his/her continuing education period shall be grounds for the denial of his/her application for the renewal of his/her certificate. An operator that fails to satisfactorily complete the required number of continuing education hours during his/her continuing education period due to extenuating circumstances may make a written request to the Board for an extension of time to do so. All requests by an operator for an extension of time to meet the continuing education requirement must be made in writing to the Board either within two months of the elapsed continuing education period or by the date of return of the operator to active employment, whichever is later. All such requests must be accompanied by complete supporting documentation of the circumstances causing the failure to meet the continuing education requirement.
- (4) Notification of Satisfactory Completion. An operator shall notify the Board Secretary upon his/her satisfactory completion of the continuing education requirement by furnishing appropriate documentation of course completion. Notification by the operator is not necessary in those cases where an agency notifies the Board Secretary of such activity.
- (5) A certified operator shall only receive credit for a continuing education course that is completed in its entirety. A certified operator attending the same continuing education course more than once in two consecutive continuing education periods shall only receive credit for the operator's first attendance.

**Authority:** T.C.A. §§ 4-5-201, et seq. and 68-221-901, et seq. **Administrative History:** Original rule filed May 21, 2014; effective August 19, 2014. Rule renumbered from 1200-05-03. Amendments filed April 12, 2021; effective July 11, 2021.

**0400-49-01-.11 SUMMARY SUSPENSION AND REVOCATION OF CERTIFICATE.**

- (1) An operator's certificate may be revoked when:
  - (a) In accordance with paragraph (2) of this rule, an operator has not used reasonable care, judgment, or the application of his/her knowledge in the performance of his/her duties as a certified operator, or
  - (b) In accordance with paragraph (3) of this rule, an operator is incompetent to perform those duties properly; or
  - (c) In accordance with paragraph (4) of this rule, an operator has practiced fraud or deception.
- (2) An operator shall be deemed to have not used reasonable care, judgment, or the application of his/her knowledge in the performance of his/her duties if he/she does not comply with the laws, rules, permit requirements, or orders of any governmental agency or court which govern the water supply system or the wastewater system he/she operates. Such acts of noncompliance include but are not limited to the following:
  - (a) The intentional or the negligent failure by the operator or persons under his/her supervision to act that results in a water supply system facility or a wastewater system facility not operating in the manner in which it is capable of being operated for the performance of its designed function.
  - (b) The intentional or the negligent failure by the operator or persons under his/her supervision to comply with the monitoring, sampling, analysis, or reporting requirements for a water supply system facility or a wastewater system facility.
  - (c) The intentional or the negligent unlawful discharge of wastes from a water supply system facility or a wastewater system facility.
  - (d) The intentional or the negligent failure by the operator or persons under his/her supervision to notify the Department of conditions: which may affect the quantity or quality of water being supplied to the customers of a water supply system; which cause the pollution of the waters of the State of Tennessee; or, which are violative of a standard of water quality promulgated by any governmental agency.
- (3) An operator shall be deemed to be incompetent to perform his/her duties properly when he/she does not possess the basic skills and knowledge necessary to operate a water supply system facility or a wastewater system facility including laboratory functions or if he/she fails to have a system of verification and oversight of employees under his/her charge. Incompetency shall be determined by examining the technical skills of the operator in operating the type of facility of which he/she is in direct charge.
- (4) An operator shall be deemed to have practiced fraud or deception as follows:
  - (a) Obtained his/her certificate through fraud, deceit, or the submission of inaccurate data regarding his/her qualifications upon his/her application for a certificate.;
  - (b) Has practiced fraud or deception during the performance of his/her duties as a certified operator; or
  - (c) Has prepared and/or signed reports of laboratory analysis results for the system that:

(Rule 0400-49-01-.11, continued)

of the notice at the affected operator's dwelling house or usual place of abode with some person of suitable age and discretion residing therein, whose name shall appear on the proof of service or return receipt card. Service may also be made by delivering the notice or copy to an agent authorized by appointment or by law to receive service on behalf of the affected operator, or by any other method allowed by law in judicial proceedings.

(6) Summary Suspension and Revocation

- (a) The Commissioner may initiate the process of summary suspension and revocation of the certificate when the Commissioner believes that an emergency action is needed to protect the public health, safety or welfare.
  - (b) The Commissioner shall give a notice to the affected operator by any reasonable means and shall inform the affected operator of the intended action, the acts or conduct that warrants summary suspension and revocation of the certificate and hold an informal hearing, as provided in T.C.A. § 4-5-320(d), to give the operator an opportunity to address the issue of whether there is an emergency.
  - (c) The Commissioner shall appoint a hearing officer to conduct this T.C.A. § 4-5-320(d) hearing and the hearing shall be recorded and transcribed.
  - (d) After the informal hearing as provided in T.C.A. § 4-5-320(d), if the Commissioner determines that an emergency action is warranted, the Commissioner shall issue an Order of Summary Suspension and a notice of hearing for revocation and include a recommendation to the Board to reinstate or not to reinstate the certificate. Any recommendation of reinstatement of the certificate shall include terms for such reinstatement.
  - (e) The Order of Summary Suspension and the notice for revocation shall contain the information required by part (5)(d)1. of this rule and be served in accordance with part (5)(d)2. of this rule.
  - (f) When the Commissioner has issued an Order of Summary Suspension and Notice of Revocation, the Board shall conduct its revocation hearing and render a decision within ninety (90) days of the operator's summary suspension. In the event the Board does not render its decision within ninety (90) days of the operator's summary suspension, the Order of Summary Suspension shall expire and no longer be in force or effect. However, the Commissioner may reissue an Order of Summary Suspension in accordance with this paragraph, for a period not to exceed ninety (90) days.
- (7) The revocation hearing before the Board shall be held in accordance with T.C.A. §§ 4-5-301 et seq. and Rule Chapter 1360-04-01 Uniform Rules of Procedure for Hearing Contested Cases Before State Administrative Agencies.
  - (8) The Board may revoke the certificate of an operator when it is found that the operator has practiced fraud or deception; that reasonable care, judgment or the application of such operator's knowledge was not used in performance of such operator's duties; or that the operator is incompetent to properly perform such operator's duties. If the certificate is revoked and is to be reinstated, the Board shall determine the timing, terms and conditions for reinstatement.
  - (9) An operator who receives an order of the Board for the revocation of his/her certificate may appeal the order to the Chancery Court of Davidson County within sixty (60) days.

(Rule 0400-49-01-.11, continued)

- (10) An operator whose certificate is revoked for failure to use reasonable care, judgment or the application of operator knowledge in performing the operator's duties or for incompetency shall be ineligible to again apply for certification as an operator for a minimum of one (1) year. An operator whose certificate is revoked for practicing fraud or deception, willfully violating regulations or permit conditions, or falsifying records and reports shall be ineligible to again apply for certification as an operator for a minimum of five years. When an operator whose certificate has been revoked has applied for a certificate after the minimum time has passed, the Board shall determine whether the operator has taken appropriate action to address the circumstances that were the cause of the revocation. The Board may request records and review his/her experience, education, training and past performance. The Board may request the former operator's presence at a meeting of the Board and interview him/her to assess the potential of future violations. After the reviews, the Board shall decide to accept or refuse the application.

**Authority:** T.C.A. §§ 4-5-201, et seq. and 68-221-901, et seq. **Administrative History:** Original rule filed May 21, 2014; effective August 19, 2014. Rule renumbered from 1200-05-03.

#### **0400-49-01-.12 CIVIL PENALTIES.**

- (1) The Commissioner may assess the civil penalty authorized by law against a municipality, utility district, corporation, or any person operating a water supply system or a wastewater system if the competency of the person in direct charge of a system facility has not first been certified in accordance with these rules.
- (2) A certified operator may be assessed the civil penalty authorized by law for the same acts and omissions that would constitute grounds for the revocation of his/her certificate by the Board.
- (3) Prior to issuing an order that assess a civil penalty, in accordance with paragraphs (1) and (2) of this rule the Commissioner may hold a show cause meeting with the person or entity to whom the order is proposed to be issued.

**Authority:** T.C.A. §§ 4-5-201, et seq. and 68-221-901, et seq. **Administrative History:** Original rule filed May 21, 2014; effective August 19, 2014. Rule renumbered from 1200-05-03.

**COMMUNITY  
PUBLIC WATER SYSTEMS  
DESIGN CRITERIA**

**Division of Water Resources  
Tennessee Department of Environment and Conservation  
2018**

## TABLE OF CONTENTS

	Page
Introduction .....	1
Part 1. Submission of Engineering Documents .....	2
1.0 General .....	2
1.1 Engineer's Report.....	2
1.2 Plans .....	5
1.3 Specifications .....	7
1.4 Revisions to Approved Plans.....	7
1.5 As-Built Plans.....	7
Part 2. General Design Considerations .....	8
2.1 Plant Layout.....	8
2.2 Building Layout.....	8
2.3 Standby Power.....	8
2.4 Automatic Equipment.....	8
2.5 Storage and Shop Space .....	9
2.6 Provisions for Future Expansion .....	9
2.7 Metering .....	9
Part 3. Source Development .....	10
3.0 General .....	10
3.1 Surface Water .....	10
3.2 Ground Water .....	11
3.3 General Well Construction Requirements .....	12
Part 4. Treatment .....	20
4.0 General .....	20
4.1 Clarification .....	20
4.2 Filtration .....	23
4.3 Package Treatment Plants, Membranes and Other Technologies .....	29
4.4 Disinfection .....	29
4.5 Softening.....	31
4.6 Aeration .....	33
4.7 Iron and Manganese Control .....	34
4.8 Fluoridation .....	36
4.9 Corrosion Control .....	37
4.10 Taste and Odor Control .....	38
4.11 Waste Disposal .....	39
Part 5. Chemical Application.....	41
5.0 General .....	41
5.1 Feed Equipment.....	41
5.2 Chemicals .....	45
5.3 Housing.....	47
5.4 Operator Safety.....	48

Page

Part 6. Laboratory Facilities .....	49
6.0 General .....	49
6.1 Equipment.....	49
6.2 Laboratory Space and Facilities.....	49
6.3 Sample Taps .....	49
Part 7. Pumping Facilities.....	50
7.0 General .....	50
7.1 Location.....	50
7.2 Ground Water Facilities.....	50
7.3 Surface Water Facilities.....	51
7.4 Booster Pumps.....	52
7.5 Automatic and Remote Controlled Stations .....	53
7.6 Appurtenances .....	53
Part 8. Finished Water Storage .....	54
8.0 General .....	54
8.1 Plant Storage.....	56
8.2 Pressure Tanks.....	56
8.3 Distribution Storage.....	57
Part 9. Distribution Systems .....	59
9.0 System Design .....	59
9.1 Installation of Mains .....	60
9.2 Separation of Water Mains and Sewers .....	61
9.3 Surface Water Crossings .....	62
9.4 Cross Connections .....	62
9.5 Water Services and Plumbing.....	62
9.6 Materials-General .....	62
9.7 Pipe.....	63
9.8 Valve, Air Relief, Meter and Blow-off Chambers.....	64



### Part 7 - PUMPING FACILITIES

- 7.0 GENERAL - Pumping facilities shall be designed to maintain the sanitary quality of pumped water. Subsurface pits or pump rooms and inaccessible installations should be avoided. No pumping station shall be subject to flooding.
- 7.1 LOCATION - The pumping station shall be so located that the proposed site will meet the requirements of the sanitary protection of the water quality, hydraulics of the system and be protected against interruption of service by fire, flood or any other hazard.
- 7.1.1 Site Protection - The station shall be:
- a. elevated to a minimum of one foot above the 100-year flood elevation, or protected to such elevation;
  - b. accessible at all times unless permitted to be out of service for period of inaccessibility;
  - c. graded around station so as to lead surface drainage away from the station;
  - d. protected to prevent vandalism and entrance by unauthorized persons or animals.
- 7.2 GROUND WATER FACILITIES - Where pumping facilities are used, wells and springs shall be vented by properly hooded and screened pipe extending at least 12 inches above the pump floor. Where necessary, provision shall be made for lubricating the pump from a point at least 6 inches above the top of the well cover, by means which will prevent contamination of the water supply.
- 7.2.1 Drilled Wells - Pumping stations located over drilled wells shall;
- a. have riser pipe or casing extending at least 6 inches, and preferably 12 inches, above the floor, and be equipped with flange or suitable stuffing box;
  - b. have riser pipe or casing firmly connected to the pump structure to provide a water tight connection.
  - c. have base of pump not less than 6 inches above pump room floor;
  - d. have pump foundation and base designed to prevent water from coming into contact with the joint.
- 7.2.2 Submersible Pumps - Where a submersible pump is used, the top of the casing shall be effectively sealed against entrance of water under all conditions of vibration or movements of conductors or cables.
- 7.2.3 Discharge Piping - Discharge piping should be provided with means to pump to waste but shall not be directly connected to a sewer. The discharge line shall:
- a. have control valves located above pump floor;
  - b. be protected against freezing;
  - c. be valved to permit testing and control of each well;
  - d. have watertight joints;

- e. have all exposed valves protected.

7.3 SURFACE WATER FACILITIES - Pump stations normally associated with surface water sources, either as raw or finished water pump stations, shall:

- a. have adequate space for the installation of additional units if needed, and for the safe servicing of all equipment;
- b. be of durable character, fire and weather resistant and with outward opening doors;
- c. have floor elevation of at least 6 inches above finished grade;
- d. have underground structure waterproofed;
- e. have all floors drained without impairing the quality of water being handled and if equipment is contained on the floor, the floor shall have sufficient slope to drain adequately.
- f. provide suitable outlet for drainage from-pump glands without discharging onto the floor.

7.3.1 Suction Well - Suction wells shall:

- a. be watertight;
- b. have floors sloped to permit removal of water and entrained solids;
- c. be covered or otherwise protected against contamination; including pump lubricant.

7.3.2 Equipment Servicing - Pump facilities shall be provided with;

- a. crane-ways, hoist beams, eye bolts, or other adequate facilities for servicing or removal of pumps, meters or heavy equipment;
- b. openings in floors, roofs or wherever else needed for removal of heavy or bulky equipment;
- c. a convenient tool board or other facilities as needed for proper maintenance of the equipment.

7.3.3 Stairways and Ladders - Stairways or ladder shall

- a. be provided between all floors, in pits or compartments which must be entered.
- b. have handrails on both sides, and treads of non-slip material.

Stairs are preferred in areas where there is frequent traffic or where supplies are transported by hand. They shall have risers not exceeding 9 inches and treads wide enough for safety.

7.3.4 Heating - Provision shall be made for adequate heating for:

- a. comfort of the operator;
- b. the safe and efficient operation of the equipment.

In pump houses not occupied by personnel, only enough heat need be provided to prevent freezing of equipment or treatment process.

- 7.3.5 Ventilation - Adequate ventilation shall be provided for all pumping stations. Forced ventilation of at least 6 changes of air per hour shall be provided for:
- all rooms, compartments, pits and other enclosures below grade floor;
  - any area where unsafe atmosphere may develop or where excessive heat may be built up.
- 7.3.6 Dehumidification - In areas where excess moisture could cause hazards to safety or damage to equipment means for dehumidification shall be provided.
- 7.3.7 Lighting - Pump stations shall be adequately lighted throughout. All electrical work shall conform to the requirements of the American Insurance Association and related agencies and to relevant State and/or local codes.
- 7.3.8 Sanitary and Other Conveniences - Pumping stations which are manned for extended periods shall be provided with potable water, lavatory and toilet facilities. Plumbing must be so installed as to prevent contamination of a public water supply. Wastes shall be discharged in accordance with Section 4.11 of these standards.
- 7.3.9 Pumps - At least 2 pumping units shall be provided. Each pumping unit shall be capable of carrying the peak demand. If more than 2 units are installed, they shall have sufficient capacity so that any 1 pump can be taken out of service and the remaining pumps are capable of carrying the peak demand. The pumping units shall:
- have ample capacity to supply the peak demand without dangerous overloading;
  - be driven by a prime mover able to operate against the maximum head and air temperature which may be encountered;
  - have spare parts and tools readily available.
- 3600 RPM pumps are not desirable and should be avoided if at all possible.
- 7.3.10 Suction Lift - Suction lift pumps will be considered on an individual basis based on justification of design engineer.
- 7.4 **BOOSTER PUMPS** - Booster pumps shall be located or controlled so that:
- they will not produce negative pressure anywhere in the distribution system;
  - the pressure in the suction line shall be maintained at or above 20 psi by the use of a pressure sustaining valve or low pressure cutoff device.
  - automatic or remote control devices shall have a range between the start and cutoff pressure which will prevent excessive cycling.
- 7.4.1 In-line Booster Pumps - In addition to the other requirements of this section, in-line booster pumps shall be accessible for servicing and repairs.
- 7.4.2 The criteria in this section also apply to fire pumps.
- 7.4.3 Booster pumps shall not serve more than 50 service connections unless gravity storage is provided or service pressure can be maintained above 20 psi without the pumps running.

7.5 AUTOMATIC AND REMOTE CONTROLLED STATIONS - All automatic stations should be provided with automatic signaling apparatus which will report when the station is out of service. All remote controlled stations shall be electrically operated and controlled and shall have signaling apparatus of proven performance. Installation of electrical equipment shall conform with the National Electrical Code.

7.6 APPURTENANCES

7.6.1 Valves - Pumps shall be adequately valved to permit satisfactory operation, maintenance and repair of the equipment. If foot valves are necessary they shall have a net valve area of at least 2½ times the area of the suction pipe and they shall be screened. Each pump shall have a positive acting check valve on the discharge side between the pump and shutoff valve.

7.6.2 Piping - In general, piping shall:

- a. be designed so that the friction head will be minimized;
- b. not be subject to contamination;
- c. have watertight joints;
- d. be protected against surge or water hammer;
- e. be such that each pump has an individual suction line or the lines shall be so manifolded that they will insure similar hydraulic and operation conditions.

7.6.3 Gauges and Meters - Each pump shall:

- a. shall have a standard pressure gauge on its discharge line;
- b. shall have a compound gauge on its suction line;
- c. shall have recording gauges in larger stations;
- d. should have a means for measuring the discharge.

The larger stations should have indicating, totalizing and recording metering of the total water pumped.

7.6.4 Water Seals - Water seals shall not be supplied with water of a lesser sanitary quality than that of the water being pumped.

7.6.5 Controls - Pumps, their prime movers and accessories, shall be controlled in such a manner that they will operate at rated capacity without dangerous overload. Where two or more pumps are installed, provision shall be made for proper alternation. Provision shall be made to prevent operation of the pump during the backspin cycle. Electrical controls should be located above grade.

7.6.6 Power - When power failure would result in cessation of minimum essential service, power supply shall be provided from at least two independent sources or standby or auxiliary source shall be provided.

7.6.7 Auxiliary Power Supply - When automatic pre-lubrication of pump bearings is necessary, and an auxiliary power supply is provided, the pre-lubrication line shall be provided with a valved by-pass around the automatic control.

## Part 8 - FINISHED WATER STORAGE

8.0 GENERAL - The materials and designs used for finished water storage structures shall provide stability and durability as well as protect the quality of the stored water. Steel structures shall follow the current AWWA standards concerning steel tanks, standpipes, reservoirs, and elevated tanks wherever they are applicable. Prestressed concrete tanks shall meet applicable AWWA Standards. Other materials of construction are acceptable when properly designed to meet the requirements of this part.

### 8.0.1 Location

- a. The bottom of ground-level reservoirs should be placed at the normal ground surface and above maximum flood level.
- b. Where the bottom must be below normal ground surface, it should be placed above the ground water table. Sewers, drains, standing water, and similar sources of contamination must be kept at least 50 feet from the reservoir. Mechanical-joint water pipe, pressure tested in place to 50 psi without leakage, may be used for gravity sewers at lesser separations.
- c. The top of a ground-level reservoir should not be less than 2 feet above normal ground surface and any possible flood level. Clearwells constructed under filters may be excepted from this requirement when the total design gives the same protection.

8.0.2 Protection - All new finished water storage structures shall have suitable watertight roofs or covers which exclude birds, animals, insects, and excessive dust.

8.0.3 Protection from Trespassers - Fencing, locks on access manholes, and other necessary precautions shall be provided to prevent trespassing, vandalism, and sabotage.

8.0.4 Drains - No drain on a water storage structure may have a direct connection to a sewer or storm drain. Splash pad and drainway shall be provided to prevent erosion.

8.0.5 Overflow - The overflow pipe of a water storage structure should be brought down near the ground surface and discharged over a drainage inlet structure or a splash plate and flow onto a drainway which is rip-rapped or otherwise protected to minimize erosion. No overflow may be connected directly to a sewer or storm drain.

- a. When an internal overflow pipe is used, it shall be located in the access tube.
- b. The overflow of a ground-level structure shall be high enough above normal or graded ground surface to prevent the entrance of surface water.
- c. The overflow shall be protected with a twenty-four mesh non-corrodible screen and a flap valve.

8.0.6 Access - Finished water storage structures shall be designed with reasonably convenient access to the interior for cleaning and maintenance. Manholes on scuttles above waterline:

- a. shall be framed at least 4 inches, and preferably 6 inches, above the surface of the roof at the opening; on ground-level structures manholes should be elevated 24 to 36 inches above the top or covering sod;
- b. shall be fitted with a solid watertight cover which overlaps the framed opening and extends down around the frame at least 2 inches;

- c. should be hinged at one side;
  - d. shall have a locking device,
  - e. shall be a minimum of 20 inches in diameter or equivalent.
- 8.0.7 Vents - Finished water storage structures shall be vented by special vent structures. Open construction between the side wall and roof is not permissible. These vents:
- a. shall prevent the entrance of surface water;
  - b. shall exclude birds and animals;
  - c. shall exclude insects and dust, as much as this function can be made compatible with effective venting; for elevated tanks and standpipes, 4-mesh non-corrodible screen may be used;
  - d. shall, on ground-level structures, terminate in an inverted U construction, the opening of which is 24 to 36 inches above the roof of sod and is covered with 24-mesh non-corrodible screen cloth.
- 8.0.8 Roof and Sidewall - The roof and sidewalls of all structures must be watertight with no openings except properly constructed vents, manholes, overflows, risers, drains, pump mountings, control ports, or piping for inflow and outflow.
- a. Any pipes running through the roof or sidewall of a finished water storage structure must be welded or properly gasketed in metal tanks, or should be connected to standard wall castings which were poured in place during the forming of a concrete structure; these wall castings should have flanges embedded in the concrete.
  - b. openings in a storage structure roof or top, designed to accommodate control apparatus or pump columns, shall be curbed and sleeved with proper additional shielding to prevent the access of surface or slop water to the structure.
  - c. Valves and controls should be located outside the storage structure so that valve stems and similar projections will not pass through the roof or top of the reservoir.
- 8.0.9 Drainage for Roof or Cover - The roof or cover of the storage structure should be well drained, but downspout pipes shall not enter or pass through the reservoir; parapets, or similar construction which would tend to hold water and snow on the roof will not be approved.
- 8.0.10 Safety - The safety of employees must be considered in the design of the storage structure. As a minimum, such matters shall conform to pertinent laws and regulations.
- a. Ladders, ladder guards, balcony railings, and safe location of entrance hatches shall be provided where applicable.
  - b. Elevated tanks with riser pipes over 8 inches in diameter shall have protective bars over the riser openings inside the tank.
- 8.0.11 Freezing - All finished water storage structures and their appurtenances, especially the riser pipes, overflows, and vents, shall be designed to prevent freezing which will interfere with proper functioning.

- 8.0.12 Grading - The area surrounding a ground-level structure should be graded in a manner that will prevent surface water from standing within 50 feet of the structure.
- 8.0.13 Silt stop - The discharge pipe of the reservoir shall be located in a manner that will prevent the flow of sediment into the distribution systems. Either a permanent or removable silt stop shall be provided at least 4 inches above the bottom of the storage structure.
- 8.0.14 Painting and/or Cathodic Protection - Proper protection should be given to metal surfaces by paints or other protective coatings, by cathodic protective devices, or by both.
- a. Paint systems consistent with current American Water Works Association standards, or otherwise acceptable to the Department shall be used. All paints must be acceptable to FDA and EPA for contact with potable water.
  - b. Cathodic protection should be designed and installed by competent technical personnel.
- 8.0.15 Turnover of water - If the storage reservoir is sized larger than required for initial demand and there is more than 2 days storage, provisions shall be made for turnover of the water in the tank and/or booster chlorination. Internal piping arrangements to prevent water stratification in ground level standpipes are recommended. For large, ground level tanks/reservoirs, piping and/or check valves can be installed to force water in and out of the tank at different locations in order to minimize dead/stagnant water zones.
- 8.0.16 Sampling - A suitable sampling tap should be provided on all storage structures and be protected from public access.
- 8.0.17 Disinfection - Finished water storage structures shall be disinfected in accordance with AWWA Standard C652 before being put in service.
- 8.1 PLANT STORAGE - The applicable design standards of this part shall be followed for plant storage.
- 8.1.1 Washwater Tanks - If washwater tanks are used, they shall be sized, in conjunction with available pump units and finished water storage, to give the back wash water required by Section 4.2.1.K.
- a. Consideration must be given to the possibility of having to wash more than one filter at a time, or several filters in succession.
- 8.1.2 Clearwell - Clearwell storage should be sized, in conjunction with distribution system storage, to relieve the filters from having to follow fluctuations in water use to meet peak demands, including filter backwash water. Design shall include features to minimize short circuiting.
- a. When finished water storage is used to provide proper contact time for chlorine, (see Section 4.4.2), special attention must be given to size and baffling.
  - b. An overflow shall be provided and must be protected with a screen and flap valve.
- 8.1.3 Adjacent Compartments - finished water must not be stored or conveyed in a compartment adjacent to unsafe water when the two compartments are separated by a single wall.
- 8.1.4 Basins and Wet-Wells - Receiving basins and pump wet-wells for finished water shall be designed as finished water storage structures.
- 8.2 PRESSURE TANKS - Hydropneumatic (pressure) tanks may be acceptable in some circumstances where the number being served is 50 connections or less. When used, they shall meet ASME code requirements or

equal which comply with the requirements of state and local laws and regulations for the construction and installation of unfired pressure vessels.

8.2.1 Location - The tank should be located above normal ground surface and be completely housed, or earth-mounted with one end projecting into an operating house, to prevent freezing.

8.2.2 Bypass - tank should have bypass piping to permit operation of the system while the tank is being repaired or painted.

8.2.3 Appurtenances - Each tank should have an access manhole, a drain, a control equipment consisting of pressure gage, water sight glass, automatic or manual air blow-off, mechanical means for adding air, and pressure-operated start-stop controls for the pumps.

8.2.4 Sizing -

a. The capacity of each well and/or pump in a hydropneumatic system should be at least ten times the average daily consumption rate of the community or the maximum peak demand whichever is greater.

b. The gross volume of the hydropneumatic tank, in gallons, should be at least 20 times the capacity of the largest pump, rated in gallons per minute.

8.2.5 Auxiliary power - Auxiliary power with automatic takeover capability shall be provided when positive pressures are not available from system gravity flow.

8.3 DISTRIBUTION STORAGE - The applicable design standards of this part shall be followed for distribution storage.

8.3.1 The purpose of system storage is to have sufficient water available to provide adequate flow and pressure at peak demand as well as to provide for fire flows when needed. For most water systems a satisfactory rule-of-thumb to meet these needs is to provide at least the average 24-hour demand in elevated storage. In the absence of an acceptable engineering study of the amount of water the system needs to meet customer demand and to provide for fire emergencies, the projected 24-hour demand at the end of the planning period will be the minimum requirement for elevated storage. This requirement may be reduced when the source, treatment facilities and pumps have sufficient capacity with standby power capability to supplement peak demands of the system.

8.3.2 Pressure Variation - System pressure variation on account of changes in level of water in storage structures should be minimized. Elevated storage tanks or large diameter ground tanks located on high ground should be the usual choices. Standpipes will not normally be approved and must be completely justified if proposed.

8.3.3 Drainage - Storage structures which float on the distribution system should be designed to drain for cleaning or maintenance without necessitating loss of pressure in the distribution system. The drains should discharge to the ground surface with no direct connection to a sewer or storm drain. (See Section 8.0.4). A nearby fire hydrant may be considered as a drain as long as service is not interrupted and suitable erosion protection is provided.

8.3.4 Level Controls - Adequate controls shall be provided to maintain levels in distribution system storage structures.

a. Telemeter equipment should be used when pressure-type controls are employed and any appreciable head loss occurs in the distribution system between the source and the storage structure.



- b. Altitude valves or equivalent controls may be required for a second and subsequent structures on the system.
- c. Overflow and low-level warnings or alarms should be located at places in the community where they will be under responsible surveillance on a 24-hour basis.

## Part 9 - DISTRIBUTION SYSTEMS

### 9.0 SYSTEM DESIGN

#### 9.0.1 Minimum Pipe Size

- a. The minimum size of pipe for principal water mains and for water mains where fire hydrants are to be attached shall be 6-inch diameter.
- b. Size of water mains shall be justified by hydraulic analysis. 2-inch water mains will only be considered for short cul-de-sacs and permanent dead-ends where future growth is not feasible. The length of 2-inch mains shall be restricted to 3000 feet in any one direction.
- c. All water mains including those not designed to provide fire protection shall be sized after a hydraulic analysis based on flow demands and pressure requirements. The system shall be designed to maintain a minimum pressure of 20 psi at ground level at all points in distribution system under all conditions of flow.
- d. Wide variations in pressure above the minimum requirement of 20 psi may be inherent in the design of a distribution system but pressures no greater than 100 psi should be delivered to the customer (unless higher pressures are requested.). Main line pressure reducing valves can be used to reduce pressures below 100 psi where feasible. Where water pressures over 100 psi are necessary to the operation of the distribution system, customers must have individual pressure reducing valves.
- e. All assumptions and any flow data used must be clearly documented and submitted with the hydraulic analysis. if actual flow data is not available theoretical calculations shall be based on all storage facilities half-full and the Hazen-Williams friction factor appropriate for type of pipe being used but in no case greater than 130.
- f. Water distribution lines should be designed and sized for an instantaneous peak demand of 2 gpm per connection for water lines serving up to 100 residential connections. Peak design demands can be reduced to 1.5 gpm per connection for 150 residential connections, 1.0 gpm per connection for 300 residential connections, 0.75 gpm per connection for 500 residential connections, and 0.5 gpm per connection for 1000 or more residential connections.

#### 9.0.2 Fire Protection

- a. The minimum pipe size to which a fire hydrant may be connected is 6-inch.
- b. Ordinarily fire hydrants shall not be connected to water mains which are not capable of providing a flow of 500 gpm at 20 psi. When a municipality or county enacts a restrictive use ordinance prohibiting pumper trucks from connecting to restricted fire hydrants which are painted a distinctive color and when a copy of this ordinance is on file at this office, we will permit fire hydrants to be connected to 6-inch mains which do not have the required pressure and flow.
- c. When fire protection is to be provided, system design should consider the recommendations of the state Insurance Services Organization.
- d. Fire hydrants shall meet current AWWA Standard C502.

#### 9.0.3 Dead Ends

- a. Dead ends shall be minimized.
- b. Where dead-end mains occur they should be provided with a fire hydrant, when fire flows are available, or blow-off for flushing purposes. The blow-off shall be at least 2 inches in diameter, but should provide flushing velocities of 2 feet per second or greater.
- c. No flushing device shall be directly connected to any sewer nor be subject to flooding or plugging.

## 9.1 INSTALLATION OF MAINS

9.1.1 Adequate support shall be provided for all pipes.

9.1.2 A continuous and uniform bedding shall be provided in the trench for all buried pipe.

9.1.3 Rock Excavation - Stones found in the trench shall be removed for a depth of at least six inches below the bottom of the pipe.

9.1.4 Cover - All distribution mains shall be provided with sufficient earth or other suitable cover to prevent freezing. This shall not be less than 30 inches measured above the top of the pipe.

9.1.5 Hydrostatic Tests

- a. Pressure and leakage tests shall be performed in accordance with current AWWA Standard C600 and/or manufacturer's installation procedures.
- b. The test pressure of the installed pipe shall be a minimum of 150 psi or 1.5 times the working pressure, whichever is greater.
- c. Allowable leakage shall be no greater than as calculated in  $L = SD / P/133,200$  where L is allowable leakage in gallons/hour, S is the length of pipe tested in feet, D is pipe diameter in inches and P is test pressure in psi.

9.1.6 Disinfection of New Water Mains - The specifications shall include detailed procedures for the adequate flushing, disinfection, and (Total Coliform) bacteriological testing of all new water mains. Disinfection as described in current AWWA Standard C651 will be accepted.

9.1.7 Disinfection When Cutting into or Repairing Existing Mains:

- a. Shall be performed when mains are wholly or partially dewatered;
- b. Shall follow current AWWA C651 procedures including trench treatment, swabbing with hypochlorite solution, flushing and/or slug chlorination as appropriate;
- c. Bacteriological testing should be done after repairs are complete but the water main may be returned to service prior to completion of testing to minimize the time customers are out of water;
- d. Leaks or breaks that are repaired with clamping devices while mains remain full of water under pressure require no disinfection.

9.1.8 When non-metallic pipe is installed, detection tape or other acceptable means of detection shall be installed.

## 9.2 SEPARATION OF WATER MAINS AND SEWERS

9.2.1 General - The following factors should be considered in providing adequate separation:

- a. materials and type of joints for water and sewer pipes;
- b. soil conditions;
- c. service and branch connections into the water main and sewer line;
- d. compensating variations in the horizontal and vertical separations;
- e. space for repair and alterations of water and sewer pipes;
- f. off-setting of pipes around manholes;
- g. water mains and sanitary or storm sewers shall not be laid in the same trench.

9.2.2 Parallel Installation

- a. Normal conditions - Water mains shall be laid at least 10 feet horizontally from any sanitary sewer, storm sewer or sewer manhole, whenever possible; the distance shall be measured edge-to-edge.
- b. Unusual conditions - When local conditions prevent a horizontal separation of 10 feet, a water main may be laid closer to a storm or sanitary sewer provided that:
  1. the bottom of the water main is at least 18 inches above the top of the sewer;
  2. where this vertical separation cannot be obtained, the sewer shall be constructed of materials and with joints that are equivalent to water main standards of construction and shall be pressure tested to assure water-tightness prior to backfilling.

9.2.3 Crossings

- a. Normal conditions - Water mains crossing house sewers, storm sewers or sanitary sewers shall be laid to provide a separation of at least 18 inches between the bottom of the water main and the top of the sewer, whenever possible.
- b. Unusual conditions - when local conditions prevent a vertical separation as described in Section 9.2.3a, the following construction shall be used:
  1. Sewers passing over or under water mains should be constructed of the materials described in Section 9.2.2b2.
  2. Water mains passing under sewers shall, in addition, be protected by providing:
    - i. a vertical separation of at least 18 inches between the bottom of the sewer and the top of the water main;
    - ii. adequate structural support for the sewers to prevent excessive deflection of joints and settling on and breaking the water mains;

- iii. that the length of water pipe be centered at the point of crossing so that the joints will be equidistant and as far as possible from the sewer.
  - iv. both the sewer and the water main shall be constructed of water pipe and tested in accordance with Section 9.1.5.
- 9.2.4 Sewer manholes - No water pipe shall pass through or come into contact with any part of a sewer or sewer manhole.
- 9.3 SURFACE WATER CROSSINGS - Surface water crossings, both over and under water, present special problems which should be discussed with the Department before final plans are prepared.
  - 9.3.1 Above-water crossings - The pipe shall be:
    - a. adequately supported;
    - b. protected from damage and freezing;
    - c. accessible for repair or replacement.
  - 9.3.2 When crossing water courses which are greater than 15 feet in width:
    - a. The pipe shall be of special construction, having flexible, watertight joints;
    - b. Valves shall be provided at both ends of water crossing so that the section can be isolated for test or repair; the valves shall be easily accessible and not subject to flooding;
    - c. Sampling taps should be available at each end of the crossing;
    - d. Permanent taps should be made for testing and locating leaks.
- 9.4 CROSS CONNECTIONS
  - a. There shall be no physical connection between the distribution system and any pipes, pumps, hydrants, or tanks whereby unsafe water and other contaminating materials may be discharged or drawn into the system.
  - b. The approval of the Department shall be obtained for interconnections between potable water supplies.
  - c. Neither steam condensate nor cooling water from engine jackets or other heat exchange devices shall be returned to the potable water supply.
- 9.5 WATER SERVICES AND PLUMBING - Water services and plumbing shall conform to relevant local and/or state plumbing codes, or to the Standard Plumbing Code.
- 9.6 MATERIALS - GENERAL
  - a. Pipe selected shall have been manufactured in conformity with the latest standards issued by the American Water Works Association, if such standards exist, and be acceptable to the Department.
  - b. in the absence of such standards, pipe meeting applicable ASTM and ANSI criteria and acceptable to the Department may be selected.

9.7.5 Polyethylene pipe for water distribution lines shall meet the requirements of AWWA C906.

9.7.6 Molecular oriented PVC pipe shall meet the requirements of AWWA C909.

9.7.7 Any pipe material which is not specifically covered in this section will be considered on an individual basis.

9.8 VALVE, AIR RELIEF, METER AND BLOW-OFF CHAMBERS

- a. Sediment accumulations may be removed through a standard fire hydrant, and compressed air and pumping may be used for dewatering mains through hydrants.
- b. At high points in water mains where air can accumulate, provisions shall be made to remove the air by means of hydrants or air relief valves. Automatic air relief valves shall not be used in situations where flooding of the manhole or chamber may occur.
- c. Chambers of pits containing valves, blow-offs, meters or other such appurtenances to a distribution system, shall not be connected directly to any storm drain or sanitary sewer, nor shall blowoffs or air-relief valves be connected directly to any sewer.
- d. Such chambers or pits shall be drained to the surface of the ground where they are not subject to flooding by surface water, or to absorption pits underground.
- e. Valves are to be placed at all intersections of water mains but at no time greater than 4000 feet apart.
- f. Gate valves shall meet current AWWA standards.

**RULES  
OF  
TENNESSEE DEPARTMENT OF ENVIRONMENT AND CONSERVATION**

**DIVISION OF WATER RESOURCES**

**CHAPTER 0400-45-01  
PUBLIC WATER SYSTEMS**

**TABLE OF CONTENTS**

0400-45-01-.01	Authority	0400-45-01-.22	Reserved
0400-45-01-.02	Purpose	0400-45-01-.23	Reserved
0400-45-01-.03	Scope	0400-45-01-.24	Sodium Monitoring
0400-45-01-.04	Definitions	0400-45-01-.25	Volatile Organic Chemicals
0400-45-01-.05	Supervision of Design and Construction	0400-45-01-.26	Volatile Organic Chemical Sampling, Analytical and Other Requirements
0400-45-01-.06	Maximum Contaminant Levels		
0400-45-01-.07	Monitoring and Analytical Requirements	0400-45-01-.27	Reserved
0400-45-01-.08	Turbidity Sampling and Analytical Requirements	0400-45-01-.28	Reserved
		0400-45-01-.29	Use of Non-Centralized Treatment Devices
0400-45-01-.09	Inorganic Chemical Sampling and Analytical Requirements	0400-45-01-.30	Reserved
		0400-45-01-.31	Filtration and Disinfection
0400-45-01-.10	Organic Chemical Sampling and Analytical Requirements	0400-45-01-.32	Fees for Public Water Systems
		0400-45-01-.33	Control of Lead and Copper
0400-45-01-.11	Radionuclide Sampling	0400-45-01-.34	Drinking Water Source Protection
0400-45-01-.12	Secondary Drinking Water Regulations	0400-45-01-.35	Consumer Confidence Reports
0400-45-01-.13	Alternative Analytical Techniques	0400-45-01-.36	Disinfectant Residuals, Disinfection Byproducts, and Disinfection Byproduct Precursors
0400-45-01-.14	Laboratory Certification		
0400-45-01-.15	Monitoring of Consecutive Public Water Systems	0400-45-01-.37	Stage 2 Initial Distribution System Evaluation for Disinfection Byproducts
0400-45-01-.16	Siting Requirements		
0400-45-01-.17	Operation and Maintenance Requirements	0400-45-01-.38	Stage 2 Disinfection Byproducts Requirements (LRAA)
0400-45-01-.18	Reporting Requirements		
0400-45-01-.19	Notification of Customers	0400-45-01-.39	Enhanced Treatment for Cryptosporidium
0400-45-01-.20	Records Maintenance	0400-45-01-.40	Ground Water Rule
0400-45-01-.21	Monitoring for Corrosivity Characteristics	0400-45-01-.41	Revised Total Coliform Rule

**0400-45-01-.01 AUTHORITY.**

- (1) These rules and regulations are issued under the authority of the Tennessee Safe Drinking Water Act of 1983, T.C.A. §§ 68-221-701 et seq.
- (2) The Division of Water Resources is responsible for the supervision of public water systems.

**Authority:** T.C.A. §§ 4-5-201, et seq. and 68-221-701, et seq. **Administrative History:** Original rule filed August 1, 2012; effective October 30, 2012. Rule was previously numbered 1200-05-01. Amendments filed November 19, 2018; effective February 17, 2019.

**0400-45-01-.02 PURPOSE.**

- (1) The purpose of these rules and regulations is to provide guidelines for the interpretation of T.C.A. §§ 68-221-701 et seq. and to set out the procedures to be followed by the Department in carrying out the Department's primary enforcement responsibility under the Federal Safe Drinking Water Act. These rules and regulations set out the requirements which agents, employees or representatives of public water systems must meet in the following areas: in the preparation and submission of plan documents for public water systems; in the supervision of all phases of construction; in supplying safe drinking water meeting all

(Rule 0400-45-01-.02, continued)

applicable maximum contaminant levels or treatment technique requirements; in providing adequate operation and maintenance of the system; and in complying with procedural requirements for appealing orders issued by the Commissioner of the Tennessee Department of Environment and Conservation against a public water system.

- (2) Where the terms “shall” and “must” are used, practice and usage is sufficiently standardized to indicate a mandatory requirement, insofar as any complaint action by the Department is concerned. Other items, such as should, recommend, preferred, and the like, indicate desirable procedures or methods.

**Authority:** T.C.A. §§ 4-5-201, et seq. and 68-221-701, et seq. **Administrative History:** Original rule filed August 1, 2012; effective October 30, 2012. Rule was previously numbered 1200-05-01.

#### **0400-45-01-.03 SCOPE.**

These rules will apply to all public water supply systems that provide water for human consumption through pipes or other constructed conveyances, if such system has at least fifteen (15) service connections or regularly serves an average of at least twenty-five (25) individuals daily at least sixty (60) days out of the year. A public water supply system is either a community water system or a non-community water system. A community water system is a public water supply system which serves at least fifteen (15) service connections used by year-round residents or regularly serves at least twenty-five (25) year-round residents. A non-community water system is a public water supply system that is not a community water system and which generally serves a transient population such as hotels, motels, restaurants, camps, service stations churches, industry, etc. A Non-Transient Non-Community Water System is a non-community water system that regularly serves at least 25 of the same persons over six (6) months per year. These rules do not apply to public water systems which meet all of the following criteria:

- (1) Consists only of distribution and storage facilities (and does not have any collection and treatment facilities);
- (2) Obtains all of its water from, but is not owned or operated by, a public water system to which such regulations apply;
- (3) Does not sell water to any person; and
- (4) Is not a carrier which conveys passengers in interstate commerce.

**Authority:** T.C.A. §§ 4-5-201, et seq. and 68-221-701, et seq. **Administrative History:** Original rule filed August 1, 2012; effective October 30, 2012. Rule was previously numbered 1200-05-01.

#### **0400-45-01-.04 DEFINITIONS.**

- (1) “Action level” is the concentration of lead or copper in water which may determine the treatment requirements that a water system is required to complete.
- (2) “Bag Filters” are pressure-driven separation devices that remove particulate matter larger than 1 micrometer using an engineered porous filtration media. They are typically constructed on a non-rigid fabric filtration media housed in a pressure vessel in which the direction of flow is from the inside of the bag to outside.
- (3) “Bank Filtration” is a water treatment process that uses a well to recover surface water that has naturally infiltrated into ground water through a river bed or bank(s). Infiltration is typically enhanced by the hydraulic gradient imposed by nearby pumping water supply or other wells.



(Rule 0400-45-01-.04, continued)

- (4) "Benchmark" A disinfection benchmark is the lowest monthly average value of the monthly logs of *Giardia Lamblia* inactivation.
- (5) "Business Plan" means a document which identifies source(s) of income or revenue sufficient to meet expenses over a three (3) year period. The business plan will identify costs related to retaining a certified operator, estimated annual infrastructure repair costs, depreciation, facility maintenance fees, estimated annual monitoring costs, estimated costs of providing public notices, estimated administrative costs, and any and all other operational, treatment, and related costs (e.g. chemicals and other supplies used to treat water, etc.). The business plan must include the re-payment of borrowed and amortized funds.
- (6) "Capacity Development Plan" means a document(s) identifying what actions a public water system is taking or shall take to become a "viable water system." Such plan shall include information concerning retention of a Certified Operator in direct charge; system ownership and accountability; staffing and organizational structure; fiscal management and controls, source water assessment and protection plan; "business plan;" and any and all other information identifying any further action that shall be taken.
- (7) "Cartridge filters" are pressure-driven separation devices that remove particulate matter larger than 1 micrometer using an engineered porous filtration media. They are typically constructed a rigid or semi-rigid self-supporting filter elements housed in pressure vessels in which flow is from the outside of the cartridge to the inside.
- (8) "Clean compliance history" is, for the purposes of Rule 0400-45-01-.41, a record of no MCL violations under paragraph (4) of Rule 0400-45-01-.06; no monitoring violations under Rule 0400-45-01-.07 or Rule 0400-45-01-.41; and no coliform treatment technique trigger exceedances or treatment technique violations under Rule 0400-45-01-.41.
- (9) "Coagulation" means a process using coagulant chemicals and mixing by which colloidal and suspended materials are destabilized and agglomerated into flocs.
- (10) "Combined distribution system" is the interconnected distribution system consisting of the distribution systems of wholesale systems and of the consecutive systems that receive finished water.
- (11) "Community water system" means a public water system which serves at least 15 service connections used by year round residents or regularly serves at least 25 year round residents.
- (12) "Compliance cycle" means the nine year calendar year cycle during which public water systems must monitor for certain contaminants. Each compliance cycle consists of three three year compliance periods. The first calendar year cycle begins January 1, 1993 and ends December 31, 2001; the second begins January 1, 2002 and ends December 31, 2010; the third begins January 1, 2011 and ends December 31, 2019.
- (13) "Compliance period" means a three year calendar year period within a compliance cycle. Each compliance cycle has three three year compliance periods. Within the first compliance cycle, the first compliance period runs from January 1, 1993 to December 31, 1995; the second from January 1, 1996 to December 31, 1998; the third from January 1, 1999 to December 31, 2001.
- (14) "Comprehensive performance evaluation (CPE)" is a thorough review and analysis of a treatment plant's performance based capabilities and associated administrative, operation and maintenance practices. It is conducted to identify factors that may be adversely impacting a plant's capability to achieve compliance and emphasizes approaches that can be implemented without significant capital improvements. For purposes of compliance, the

(Rule 0400-45-01-.04, continued)

comprehensive performance evaluation must consist of at least the following components: assessment of plant performance; evaluation of major unit processes; identification and prioritization of performance limiting factors; assessment of the applicability of comprehensive technical assistance; and preparation of a CPE report.

- (15) "Confluent growth" means a continuous bacterial growth covering the entire filtration area of a membrane filter, or a portion thereof, in which bacterial colonies are not discrete.
- (16) "Connection" means the point at which there is a meter or service tap if no meter is present.
- (17) "Consecutive system" is a public water system that receives some or all of its finished water from one or more wholesale systems. Delivery may be through a direct connection or through the distribution system of one or more consecutive systems.
- (18) "Contaminant" means any physical, chemical, biological, or radiological substance or matter in water.
- (19) "Conventional filtration treatment" means a series of processes including coagulation, flocculation, sedimentation, and filtration resulting in substantial particulate removal.
- (20) "Corrosion inhibitor" means a substance capable of reducing the corrosivity of water toward metal plumbing materials, especially lead and copper, by forming a protective film on the interior surface of those materials.
- (21) "CT" or "CTcalc" is the product of "residual disinfectant concentration" (C) in mg/1 determined before or at the first customer, and the corresponding "disinfectant contact time" (T) in minutes, i.e., "C" x "T". If a public water system applies disinfectants at more than one point prior to the first customer, it must determine the CT of each disinfectant sequence before or at the first customer to determine the total percent inactivation or "total inactivation ratio". In determining the total inactivation ratio, the public water system must determine the residual disinfectant concentration of each disinfection sequence and corresponding contact time before any subsequent disinfection application point(s). "CT99.9" is the CT value required for 99.9 percent (3 log) inactivation of *Giardia lamblia* cysts. CT99.9 for a variety of disinfectants and conditions appear in Tables 1.1 through 1.6, 2.1, and 3.1 of part (5)(b)3. of Rule 0400-45-01-.31.

$$\frac{CT_{calc}}{CT_{99.9}}$$

is the inactivation ratio. The sum of the inactivation ratios, or total inactivation ratio shown as

$$\sum \frac{(CT_{calc})}{(CT_{99.9})}$$

is calculated by adding together the inactivation ratio for each disinfection sequence. A total inactivation ratio equal to or greater than 1.0 is assumed to provide a 3 log inactivation of *Giardia lamblia* cyst. Disinfectant concentrations must be determined by tracer studies or an equivalent demonstration approved by the Department.

- (22) "Department" when used in these rules means the Division of Water Resources, Tennessee Department of Environment and Conservation, or one of the Division's field offices.
- (23) "Diatomaceous earth filtration" means a process resulting in substantial particulate removal in which (1) a precoat cake of diatomaceous earth filter media is deposited on a support membrane (septum), and (2) while the water is filtered by passing through the cake on the

(Rule 0400-45-01-.04, continued)

septum, additional filter media known as body feed is continuously added to the feed water to maintain the permeability of the filter cake.

- (24) "Direct filtration" means a series of processes including coagulation and filtration but excluding sedimentation resulting in substantial particulate removal.
- (25) "Disinfectant" means any oxidant, including but not limited to chlorine, chlorine dioxide, chloramines, and ozone added to water in any part of the treatment or distribution process, that is intended to kill or inactivate pathogenic microorganisms.
- (26) "Disinfectant contact time" ("T" in CT calculations) means the time in minutes that it takes for water to move from the point of disinfectant application or the previous point of disinfectant residual measurement to a point before or at the point where residual disinfectant concentration ("C") is measured. Where only one "C" is measured, "T" is the time in minutes that it takes for water to move from the point of disinfectant application to a point before or at where residual disinfectant concentration ("C") is measured. Where more than one "C" is measured, "T" is (a) for the first measurement of "C", the time in minutes that it takes for water to move from the first or only point of disinfectant application to a point before or at the point where the first "C" is measured and (b) for subsequent measurements of "C", the time in minutes that it takes for water to move from the previous "C" measurement point to the "C" measurement point for which the particular "T" is being calculated. Disinfectant contact time in pipelines must be calculated based on "plug flow" by dividing the internal volume of the pipe by the maximum hourly flow rate through that pipe. Disinfectant contact time within mixing basins and storage reservoirs must be determined by tracer studies or an equivalent demonstration.
- (27) "Disinfection" means a process which inactivates pathogenic organisms in water by chemical oxidants or equivalent agents.
- (28) "Disinfection profile" is a summary of daily Giardia lamblia inactivation through the treatment plant. The procedure for developing a disinfection profile is contained in 40 CFR 141.172.
- (29) "Distribution System" means all water lines up to the point of a meter. For unmetered systems distribution system includes all lines up to the customer's service tap.
- (30) "Domestic or other non distribution system plumbing problem" means a coliform contamination problem in a public water system with more than one service connection that is limited to the specific service connection from which the coliform positive sample was taken.
- (31) "Dose Equivalent" means the product of the absorbed dose from ionizing radiation and such factors as account for differences in biological effectiveness due to the type of radiation and its distribution in the body as specified by the International Commission on Radiological Units and Measurements (ICRU).
- (32) "Dual sample set" is a set of two samples collected at the same time and same location, with one sample analyzed for TTHM and the other sample analyzed for HAA5. Dual sample sets are collected for the purposes of conducting an IDSE under the provisions of Rule 0400-45-01-.37 and determining compliance with the TTHM and HAA5 MCLs under the provisions of Rule 0400-45-01-.38.
- (33) "Effective corrosion inhibitor residual" for the purpose of the lead and copper rules only, means a concentration sufficient to form a passivating film on the interior walls of a pipe.
- (34) "Engineer" means the person or firm who designed the public water system and conceived, developed, executed or supervised the preparation of the plan documents.

(Rule 0400-45-01-.04, continued)

- (35) "Enhanced coagulation" means the addition of sufficient coagulant for improved removal of disinfection byproduct precursors by conventional filtration treatment.
- (36) "Enhanced softening" means the improved removal of disinfection byproduct precursors by precipitative softening.
- (37) "Filter profile" is a graphical representation of individual filter performance, based on continuous turbidity measurements or total particle counts versus time for an entire filter run, from startup to backwash inclusively, that includes an assessment of filter performance while another filter is being backwashed.
- (38) "Filtration" means a process for removing particulate matter from water by passage through porous media.
- (39) "Finished water" is water that is introduced into the distribution system of a public water system and is intended for distribution and consumption without further treatment, except as treatment necessary to maintain water quality in the distribution system (e.g., booster disinfection, addition of corrosion control chemicals).
- (40) "First draw sample" means a one liter sample of tap water, for the purposes of the lead and copper rules, that has been standing in plumbing pipes at least 6 hours and is collected without flushing the tap.
- (41) "Flocculation" means a process to enhance agglomeration or collection of smaller floc particles into larger, more easily settleable particles through gentle stirring by hydraulic or mechanical means.
- (42) "Flowing stream" is a course of running water flowing in a definite channel.
- (43) "GAC10" means granular activated carbon filter beds with an empty-bed contact time of 10 minutes based on average daily flow and a carbon reactivation frequency of every 180 days, except that the reactivation frequency for GAC10 used as best available technology for compliance with disinfection byproducts shall be 120 days.
- (44) "GAC20" means granular activated carbon filter beds with an empty-bed contact time of 20 minutes based on average daily flow and a carbon reactivation frequency of every 240 days.
- (45) "Gross Alpha Particle Activity" means the total radioactivity due to alpha particle emission as inferred from measurements on a dry sample.
- (46) "Gross Beta Particle Activity" means the total radioactivity due to beta particle emission as inferred from measurements on a dry sample.
- (47) "Ground water under the direct influence of surface water" means any water beneath the surface of the ground with significant occurrence of insects or other macroorganisms, algae, or large diameter pathogens such as *Giardia lamblia* or *Cryptosporidium*, or significant and relatively rapid shifts in water characteristics such as turbidity, temperature, conductivity, or pH which closely correlate to climatological or surface water conditions. Direct influence must be determined for individual sources in accordance with criteria established by the Department. The Department determination of direct influence may be based on site specific measurements of water quality and/or documentation of well construction characteristics and geology with field evaluation.
- (48) "Haloacetic acids (five) (HAA5)" mean the sum of the concentrations in milligrams per liter of the haloacetic acid compounds (monochloroacetic acid, dichloroacetic acid, trichloroacetic

(Rule 0400-45-01-.04, continued)

acid, monobromoacetic acid, and dibromoacetic acid), rounded to two significant figures after addition.

- (49) "Halogen" means one of the chemical elements chlorine, bromine or iodine.
- (50) "Human consumption" means the use of water that involves any drinking or ingestion of the water by humans, any human skin contact, or food preparation where the food is not brought to boiling temperatures after contact with the water.
- (51) "Initial compliance period" means the first full three year compliance period which begins January 1, 1993. For public water systems having fewer than 150 service connections initial compliance period shall be January 2, 1996, for the following contaminants:
- |     |                        |     |                           |
|-----|------------------------|-----|---------------------------|
| (a) | Antimony               | (m) | endrin                    |
| (b) | Beryllium              | (n) | glyphosate                |
| (c) | Cyanide                | (o) | oxamyl                    |
| (d) | Nickel                 | (p) | picloram                  |
| (e) | Thallium               | (q) | simazine                  |
| (f) | dichloromethane        | (r) | benzo(a)pyrene            |
| (g) | 1,2,4-trichlorobenzene | (s) | di(2ethylhexyl)adipate    |
| (h) | 1,1,2-trichloroethane  | (t) | di(2ethylhexyl)phthalate  |
| (i) | dalapon                | (u) | hexachlorobenzene         |
| (j) | dinoseb                | (v) | hexachlorocyclopentadiene |
| (k) | diquat                 | (w) | 2,3,7,8 TCDD              |
| (l) | endothall              |     |                           |
- (52) "Lake/reservoir" refers to a natural or man-made basin or hollow on the earth's surface in which water collects or is stored that may or may not have a current or single direction of flow.
- (53) "Large water system" for the purpose of lead and copper rule, means a water system that serves more than 50,000 persons.
- (54) "Lead service line" means a service line made of lead which connects the water main to the building inlet and any lead pigtail, gooseneck or other fitting which is connected to such lead line.
- (55) "Legionella" means a genus of bacteria, some species of which have caused a type of pneumonia called Legionnaires Disease.
- (56) "Level 1 assessment" is an evaluation to identify the possible presence of sanitary defects, defects in distribution system coliform monitoring practices, and (when possible) the likely reason that the system triggered the assessment. It is conducted by the system operator or owner. Minimum elements include review and identification of atypical events that could affect distributed water quality or indicate that distributed water quality was impaired; changes in distribution system maintenance and operation that could affect distributed water quality (including water storage); source and treatment considerations that bear on distributed water quality, where appropriate (e.g., whether a ground water system is disinfected); existing water quality monitoring data; and inadequacies in sample sites, sampling protocol, and sample processing. The system must conduct the assessment consistent with any Department directives that tailor specific assessment elements with respect to the size and type of the system and the size, type, and characteristics of the distribution system.
- (57) "Level 2 assessment" is an evaluation to identify the possible presence of sanitary defects, defects in distribution system coliform monitoring practices, and (when possible) the likely

(Rule 0400-45-01-.04, continued)

reason that the system triggered the assessment. A Level 2 assessment provides a more detailed examination of the system (including the system's monitoring and operational practices) than does a Level 1 assessment through the use of more comprehensive investigation and review of available information, additional internal and external resources, and other relevant practices. It is conducted by an individual approved by the Department, which may include the system operator. Minimum elements include review and identification of atypical events that could affect distributed water quality or indicate that distributed water quality was impaired; changes in distribution system maintenance and operation that could affect distributed water quality (including water storage); source and treatment considerations that bear on distributed water quality, where appropriate (e.g., whether a ground water system is disinfected); existing water quality monitoring data; and inadequacies in sample sites, sampling protocol, and sample processing. The system must conduct the assessment consistent with any Department directives that tailor specific assessment elements with respect to the size and type of the system and the size, type, and characteristics of the distribution system. The system must comply with any expedited actions or additional actions required by the Department in the case of an E. coli MCL violation.

- (58) "Locational running annual average (LRAA)" is the average of sample analytical results for samples taken at a particular monitoring location during the previous four calendar quarters.
- (59) "Man-Made Beta Particle and Photon Emitter" means all radionuclides emitting beta particles and/or photons listed in "Maximum Permissible Body Burdens and Maximum Permissible Concentration of Radionuclides in Air or Water for Occupational Exposure, NBS Handbook 69", except the daughter products of thorium 232, uranium 235 and uranium 238.
- (60) "Maximum contaminant level" or "MCL" means the maximum permissible level of a contaminant in water which is delivered at the free flowing outlet of the ultimate user of a public water system, except in the case of turbidity where the maximum permissible level is measured at the point of entry to the distribution system. Contaminants added to the water under circumstances controlled by the user, except those resulting from corrosion of piping and plumbing caused by water quality, are excluded from this definition.
- (61) "Maximum contaminant level goal" or "MCLG" means that the maximum level of the contaminant in drinking water at which no known or anticipated adverse effect on the health of persons would occur, and which allows an adequate margin of safety. Maximum contaminant level goals are non-enforceable health goals.
- (62) "Maximum residual disinfectant level (MRDL)" means a level of a disinfectant added for water treatment that may not be exceeded at the consumer's tap without an unacceptable possibility of adverse health effects. For chlorine and chloramines, a PWS is in compliance with the MRDL when the running annual average of monthly averages of samples taken in the distribution system, computed quarterly, is less than or equal to the MRDL. For chlorine dioxide, a PWS is in compliance with the MRDL when daily samples are taken at the entrance to the distribution system and no two consecutive daily samples exceed the MRDL. MRDLs are enforceable in the same manner as maximum contaminant levels under Section 1412 of the Safe Drinking Water Act. There is convincing evidence that addition of a disinfectant is necessary for control of waterborne microbial contaminants. Notwithstanding the MRDLs, operators may increase residual disinfectant levels of chlorine or chloramines (but not chlorine dioxide) in the distribution system to a level and for a time necessary to protect public health to address specific microbiological contamination problems caused by circumstances such as distribution line breaks, storm runoff events, source water contamination, or cross-connections.
- (63) "Maximum Total Trihalomethane Potential (MTP)" means the maximum concentration of total trihalomethanes produced in a given water containing a disinfectant residual after 7 days at a temperature of 25°C or above.

(Rule 0400-45-01-.04, continued)

- (64) "Medium-size water system" for the purpose of the lead and copper rule means a water system that serves greater than 3,300 and less than or equal to 50,000 persons.
- (65) "Membrane filtration" is a pressure or vacuum driven separation process in which particulate matter larger than 1 micrometer is rejected by an engineered barrier, primarily through a size exclusion mechanism, and which has a measurable removal efficiency of a target organism that can be verified through the application of a direct integrity test. This definition includes the common membrane technologies of microfiltration, ultrafiltration, nanofiltration, and reverse osmosis.
- (66) "Near the first service connection" means at one of the twenty percent of all service connections in the entire system that are nearest the water supply treatment facility, as measured by the water transport time within the distribution system.
- (67) "Non-community water system" means a public water system that is not a community water system. A non-community water system is either a "transient non-community water system" (TNCWS) or a "non-transient non-community water system" (NTNCWS).
- (68) "Non-transient non-community water system" or "NTNCWS" means a non-community water system that regularly serves at least 25 of the same persons over six months per year.
- (69) "Optimal corrosion control treatment" for the purpose of lead and copper rule only means the corrosion control treatment that minimizes the lead and copper concentrations at user's taps while insuring that the treatment does not cause the water system to violate any primary drinking water regulation.
- (70) "Person" means any individual, corporation, company, association, partnership, State, municipality, utility district, water cooperative, or Federal agency.
- (71) "Picocurie" (pCi) means that quantity of radioactive material producing 2.22 nuclear transformations per minute.
- (72) "Plan documents" means reports, proposals, preliminary plans, survey and basis of design data, general and detailed construction plans, profiles, specifications and all other information pertaining to public water system planning.
- (73) "Plant intake" refers to the works or structures at the head of a conduit through which water is diverted from a source (e.g., river or lake) into the treatment plant.
- (74) "Point of disinfectant application" is the point where the disinfectant is applied and water downstream of that point is not subject to recontamination by surface water runoff.
- (75) "Point-of-Entry Treatment Device" (POE) means a device applied to the drinking water entering a house or building for the purpose of reducing contaminants in the drinking water distributed throughout the house or building.
- (76) "Point-of-Use Treatment Device" (POU) means a treatment device applied to a single tap used for the purpose of reducing contaminants in drinking water at that one tap.
- (77) "Presedimentation" is a preliminary treatment process used to remove gravel, sand and other particulate material from the source water through settling before the water enters the primary clarification and filtration processes in a treatment plant.
- (78) "Primary drinking water regulation" means a rule promulgated by the Board which:

(Rule 0400-45-01-.04, continued)

- (a) Applies to public water systems;
  - (b) Specifies contaminants which, in the judgment of the Department, may have any adverse effect on the health of persons;
  - (c) Specifies for each such contaminant either:
    - 1. A maximum contaminant level, if, in the judgment of the Department, it is economically and technologically feasible to ascertain the level of such contaminant in water in public water systems, or
    - 2. If, in the judgment of the Department, it is not economically or technologically feasible to so ascertain the level of such contaminant, each treatment technique known to the Department which leads to a reduction in the level of such contaminant sufficient to satisfy the requirements of Rule 0400-45-01-.06; and
  - (d) Contains criteria and procedures to assure a supply of drinking water which dependably complies with such maximum contaminant levels or treatment techniques, including quality control and testing procedures to insure compliance with such levels and to insure proper operation and maintenance of the system, and requirements regarding (i) the minimum quality of water which may be taken into the system and (ii) siting for new facilities for public water systems.
- (79) "Public water system" means a system for the provision of piped water for human consumption if the system serves 15 or more connections or which regularly serves 25 or more individuals daily at least 60 days out of the year and includes:
- (a) Any collection, treatment, storage or distribution facility under control of the operator of such system and used primarily in connection with such system; and
  - (b) Any collection or pre-treatment storage facility not under such control which is used primarily in connection with such system.
- The population of a water system shall be determined by actual count or by multiplying the household factor by the number of connections in the system. The household factor shall be taken from the latest federal census for that county or city. Water systems serving multi-family residences such as apartment complexes and mobile home parks shall include each individual residence unit as a connection in determining the population for the system.
- (80) "Rem" means the unit of dose equivalent from ionizing radiation to the total body or any internal organ or organ system. A "millerem (mrem)" is 1/1000 of a rem.
- (81) "Repeat compliance period" means any subsequent compliance period after the initial compliance period.
- (82) "Residual disinfectant concentration" ("C" in CT calculations) means the concentration of disinfectant measured in mg/l in a representative sample of water.
- (83) "Safe Drinking Water Act" means the Federal law codified in 42 United States Code 300f et seq., Public Law 93 523, dated December 16, 1974 and subsequent amendments.
- (84) "Sanitary defect" is a defect that could provide a pathway of entry for microbial contamination into the distribution system or that is indicative of a failure or imminent failure in a barrier that is already in place.



(Rule 0400-45-01-.04, continued)

- (85) "Sanitary survey" means an on-site review of the water source, facilities, equipment, operation and maintenance of a public water system for the purpose of evaluating the adequacy of such sources, facilities, equipment, operation and maintenance for producing and distributing safe drinking water.
- (86) "Seasonal system" is a non-community water system that is not operated as a public water system on a year-round basis and starts up and shuts down at the beginning and end of each operating season.
- (87) "Secondary drinking water regulation" means a rule promulgated by the Board which applies to public water systems and which specifies the maximum contaminant levels which, in the judgment of the Board, are requisite to protect the public welfare. Such rules may vary according to geographic and other circumstances, and may apply to any contaminant in drinking water which may:
- (a) Adversely affect the odor or appearance of such water and consequently may cause the persons served by the public water system providing such water to discontinue its use; or
  - (b) Otherwise adversely affect the public welfare.
- (88) "Sedimentation" means a process for removal of solids before filtration by gravity or separation.
- (89) "Service line sample" means a one liter sample of water collected in accordance with part (7)(b)3. of Rule 0400-45-01-.33, that has been standing for at least 6 hours in a service line.
- (90) "Single family structure" for the purpose of lead and copper rules means a building constructed as a single family residence that is currently used as either a residence or a place of business.
- (91) "Slow sand filtration" means a process involving passage of a raw water through a bed of sand at low velocity (generally less than 0.4 m/h) resulting in substantial particulate removal by physical and biological mechanisms.
- (92) "Small water system" for the purpose of the lead and copper rules only, means a water system that serves 3,300 or fewer persons.
- (93) "Subpart H systems" means public water systems using surface water or ground water under the direct influence of surface water as a source that are subject to the requirements of Rules 0400-45-01-.17, 0400-45-01-.31 and 0400-45-01-.39.
- (94) "Supplier of water" means any person who owns or operates a public water system.
- (95) "Surface water" means all water which is open to the atmosphere and subject to surface runoff.
- (96) "SUVA" means Specific Ultraviolet Absorption at 254 nanometers (nm), an indicator of the humic content of water. It is a calculated parameter obtained by dividing a sample's ultraviolet absorption at a wavelength of 254 nm (UV 254/ (in m) by its concentration of dissolved organic carbon (DOC) (in mg/L).
- (97) "System with a single service connection" means a system which supplies drinking water to consumers via a single service line.

(Rule 0400-45-01-.04, continued)

- (98) "Too numerous to count" means that the total number of bacterial colonies exceeds 200 on a 47 millimeter diameter membrane filter used for coliform detection.
- (99) "Total Organic Carbon" (TOC) means total organic carbon in mg/L measured using heat, oxygen, ultraviolet irradiation, chemical oxidants, or combinations of these oxidants that convert organic carbon to carbon dioxide, rounded to two significant figures.
- (100) "Total trihalomethane" (TTHM) means the sum of concentration in milligrams per liter of the trihalomethane compounds trihalomethane (chloroform), dibromochloromethane, bromodichloro-methane and tribromomethane (bromoform), rounded to two significant figures.
- (101) "Transient non-community water system" or "TNCWS" means a non-community water system that regularly serves at least 25 individuals daily at least 60 days out of the year. A transient non-community water system is a public water supply system that generally serves a transient population such as hotels, motels, restaurants, camps, service stations churches, industry, and rest stops.
- (102) "Trihalomethane" (THM) means one of the family of organic compounds, named as derivatives of methane, wherein three of the four hydrogen atoms in methane are each substituted by a halogen atom in the molecular structure.
- (103) "Two-stage lime softening" is a process in which chemical addition and hardness precipitation occur in each of two distinct unit clarification processes.
- (104) "Uncovered finished water storage facility" is a tank, reservoir, or other facility used to store water that will undergo no further treatment except residual disinfection and is open to the atmosphere.
- (105) "Viable water system" means a public water system which has the commitment and the financial, managerial, and technical capacity to consistently comply with the Tennessee Safe Drinking Water Act and these rules.
- (106) "Virus" means a virus of fecal origin which is infectious to humans by waterborne transmission.
- (107) "Waterborne disease outbreak" means a significant occurrence of acute infectious illness, epidemiologically associated with the ingestion of water from a public water system which is deficient in treatment, as determined by the appropriate local or State agency.
- (108) "Wholesale system" is a public water system that treats source water as necessary to produce finished water and then delivers some or all of that finished water to another public water system. Delivery may be through a direct connection or through the distribution system of one or more consecutive systems.

**Authority:** T.C.A. §§ 4-5-201, et seq. and 68-221-701, et seq. **Administrative History:** Original rule filed August 1, 2012; effective October 30, 2012. Rule was previously numbered 1200-05-01. Amendments and new rules filed November 24, 2015; effective February 22, 2016. Amendments filed November 19, 2018; effective February 17, 2019.

#### **0400-45-01-.05 SUPERVISION OF DESIGN AND CONSTRUCTION.**

- (1) Engineering - Plan documents for public water systems shall be submitted to the Department at least thirty (30) days prior to the date on which action by the Department is desired.
- (2) Expiration of Approval - Approval of engineering reports, proposals, preliminary plans, survey and basis of design data shall be null and void after a period of one year from the date

(Rule 0400-45-01-.05, continued)

- (13) Delegation of Plans Review Authority - Under T.C.A § 68-221-706, any unit of local government may petition the Commissioner for certification to review and approve plans for water distribution facilities within its jurisdiction. The unit of local government must have adequate experience and expertise in water distribution and must adopt standards and impose requirements which are at least as stringent as the Department's. The request for certification must be in writing and contain at least the following:
- (a) The names of the individual(s) responsible for the review and approval together with his/her experience and education. This person(s) must be employed by the unit of local government and be a registered professional engineer in Tennessee.
  - (b) A copy of the standards, requirements and design criteria legally adopted and enforceable by the unit of local government.
  - (c) The type of projects the unit of local government wishes to receive certification to review. This may include but is not limited to water lines, distribution pumping stations and distribution storage tanks.
  - (d) Procedures for maintaining records of all projects reviewed and approved by the unit of local government.
  - (e) The wording to be used on the approval stamp.
  - (f) Plans review authority fee.

The Division of Water Resources will be responsible for reviewing the application for certification and shall have up to 60 days from the receipt of the complete application to make a written response. Units of local government will not be certified to review projects involving state or federal funds, raw water pump stations, new water sources, treatment facilities, sludge handling facilities, or any project designed by the staff of the local government. Any unit of local government which receives certification for plans review shall submit one copy of any plan documents it has approved to the Division of Water Resources. This shall be done within 10 days of the local government's approval. The commissioner may periodically review the unit of local government's plans review program and prescribe changes as deemed appropriate. The Division of Water Resources may execute a written agreement with a unit of local government which has received plans review certification. Failure to comply with the terms of the agreement may result in revocation of the plans review certification.

**Authority:** T.C.A. §§ 4-5-201, et seq. and 68-221-701, et seq. **Administrative History:** Original rule filed August 1, 2012; effective October 30, 2012. Rule was previously numbered 1200-05-01. Amendments filed November 19, 2018; effective February 17, 2019.

#### 0400-45-01-.06 MAXIMUM CONTAMINANT LEVELS.

- (1) Inorganic Chemicals
- (a) The maximum contaminant level for fluoride applies to community water systems. The maximum contaminant levels for nitrate, nitrite and total nitrate and nitrite are applicable to both community water systems and non-community water systems. The maximum contaminant levels for the remaining inorganic chemicals apply only to community water systems and non-transient non-community systems.
  - (b) The following are the maximum contaminant levels for inorganic chemicals:

CONTAMINANT	LEVEL, MILLIGRAMS PER LITER
-------------	-----------------------------

(Rule 0400-45-01-.06, continued)

1.	Antimony	0.006
2.	Arsenic	0.010
3.	Asbestos	7 million fibers/liter (longer than 10 microns)
4.	Beryllium	0.004
5.	Barium	2.0
6.	Cadmium	0.005
7.	Chromium	0.1
8.	Cyanide (as free cyanide)	0.2
9.	Fluoride	4.0
10.	Mercury	0.002
11.	Nickel	0.1
12.	Nitrate	10.0 (as Nitrogen)
13.	Nitrite	1.0 (as Nitrogen)
14.	Total nitrate and nitrate	10.0 (as Nitrogen)
15.	Selenium	0.05
16.	Thallium	0.002

- (2) Organic Chemicals - The following are the maximum contaminant levels for organic chemicals.
- (a) The following maximum contaminant levels for organic contaminants apply to community water systems and non-transient non-community water systems. The maximum contaminant levels for volatile organic chemicals are given in paragraph (2) of Rule 0400-45-01-.25.

<u>CONTAMINANT</u>	<u>LEVEL, MILLIGRAMS PER LITER</u>
1. Alachlor	0.002
2. Atrazine	0.003
3. Carbofuran	0.04
4. Chlordane	0.002
5. Dibromo chloropropane (DBCP)	0.0002
6. 2,4 Dichlorophenoxyacetic acid	0.07
7. Ethylene dibromide	0.00005

(Rule 0400-45-01-.06, continued)

levels for turbidity in drinking water, measured at a representative entry point(s) to the distribution system are:

- (a) One (1.0) turbidity unit, as determined by monthly average pursuant to Rule 0400-45-01-.08.
- (b) Two (2.0) turbidity units based on an average for two consecutive days pursuant to Rule 0400-45-01-.08.

To meet the maximum contaminant level for turbidity, a public water system must meet both subparagraphs (a) and (b) of this paragraph.

(4) Microbiological - The maximum contaminant levels for microbiologicals are applicable to both community water systems and non-community water systems.

- (a) Until March 31, 2016, the total coliform maximum contaminant level (MCL) is based on the presence or absence of total coliforms in a sample, rather than coliform density. Beginning April 1, 2016, the MCL for total coliform shall no longer be in effect.

The number of total coliform positive samples shall not exceed any of the following:

- 1. For a system which collects at least 40 samples per month, if no more than 5.0 percent of the samples collected during a month are total coliform-positive, the system is in compliance with the MCL for total coliforms.
  - 2. For a system which collects fewer than 40 samples/month, if no more than one sample collected during a month is total coliform-positive, the system is in compliance with the MCL for total coliforms.
  - 3. A public water system which has exceeded the MCL for total coliforms must report the violation to the Department no later than the end of the next business day after it learns of the violation and notify the public in accordance with the schedule of Rule 0400-45-01-.19 using the language specified in Rule 0400-45-01-.19.
  - 4. A public water system which has failed to comply with the coliform monitoring requirements, including a sanitary survey requirement must report the monitoring violation to the Department within ten (10) days after the system discovers the violation and notify the public in accordance with Rule 0400-45-01-.19.
- (b) Until March 31, 2016, any fecal coliform-positive repeat sample or E. coli-positive repeat sample, or any total coliform-positive repeat sample following a fecal coliform-positive or E. coli-positive routine sample, constitutes a violation of the MCL for total coliforms. For purposes of the public notification requirements in Rule 0400-45-01-.19, this is a violation that may pose an acute risk to health.
  - (c) Fecal coliforms/*Escherichia coli* (E. coli) testing
    - 1. If any routine or repeat sample is total coliform-positive, the system must analyze that total coliform-positive culture medium to determine if fecal coliforms are present, except that the system may test for E. coli in lieu of fecal coliforms. If fecal coliforms or E. coli are present, the system must notify the Department by the end of the day when the system is notified of the test result, unless the system is notified of the result after the Department office is closed, in which case the system must notify the Department before the end of the next business day.

(Rule 0400-45-01-.06, continued)

2. The Department has the discretion to allow a public water system, on a case-by-case basis, to forgo fecal coliform or *E. coli* testing on a total coliform-positive sample if that system assumes that the total coliform-positive sample is fecal coliform-positive or *E. coli*-positive. Accordingly, the system must notify the Department as specified in part 1. of this subparagraph and the provisions of subparagraph (b) of this paragraph apply.
- (d) A public water system must determine compliance with the MCL for total coliforms in subparagraph (a) and (b) of this paragraph for each month in which it is required to monitor for total coliforms.
  - (e) No variance or exemptions from the maximum contaminant level for total coliforms are permitted.
  - (f) Maximum contaminant level goals for microbiological contaminants.

1. MCLGs for the following contaminants are as indicated:

Contaminant	MCLG
(i) <i>Giardia lamblia</i>	zero
(ii) Viruses	zero
(iii) <i>Legionella</i>	zero
(iv) Total coliforms (including fecal coliforms and <i>Escherichia coli</i> )	zero
(v) <i>Cryptosporidium</i>	zero
(vi) <i>Escherichia coli (E. coli)</i>	zero

2. The MCLG identified in subpart 1.(iv) of this subparagraph is no longer applicable beginning April 1, 2016.
- (g) Beginning April 1, 2016, a system is in compliance with the MCL for *E. coli* for samples taken under the provisions of Rule 0400-45-01-.41 unless any of the conditions identified in parts 1. through 4. of this subparagraph occur. For purposes of the public notification requirements in Rule 0400-45-01-.19, violation of the MCL may pose an acute risk to health.
    1. The system has an *E. coli*-positive repeat sample following a total coliform positive routine sample.
    2. The system has a total coliform positive repeat sample following an *E. coli*-positive routine sample.
    3. The system fails to take all required repeat samples following an *E. coli*-positive routine sample.
    4. The system fails to test for *E. coli* when any repeat sample tests positive for total coliform.
  - (h) Until March 31, 2016, a public water system must determine compliance with the MCL for total coliforms in subparagraphs (a) and (b) of this paragraph for each month in which it is required to monitor for total coliforms. Beginning April 1, 2016, a public water system must determine compliance with the MCL for *E. coli* in subparagraph (g) of this paragraph for each month in which it is required to monitor for total coliforms.

(Rule 0400-45-01-.06, continued)

not under the direct influence of surface water must comply with this this part beginning January 1, 2004. All systems must comply with these MCLs until the date specified for Locational Running Annual Average (Stage 2 Disinfection Byproducts Requirements (LRAA)) compliance in Rule 0400-45-01-.38.

Disinfection by-product	MCL (mg/L)
Total trihalomethanes (TTHM)	0.080
Haloacetic acids (five) (HAA5)	0.060

- (ii) The Administrator, pursuant to section 1412 of the Federal Safe Drinking Water Act, hereby identifies the following as the best technology, treatment techniques, or other means available for achieving compliance with the maximum contaminant levels for TTHM and HAA5 identified in this part.

Disinfection by-product	Best available technology
Total trihalomethanes (TTHM) and Haloacetic acids (five) (HAA5)	Enhanced coagulation or enhanced softening or GAC10, with chlorine as the primary and residual disinfectant

2. LRAA compliance (Rule 0400-45-01-.38)

- (i) Compliance dates. The Stage 2 Disinfection Byproducts Requirements (LRAA) MCLs for TTHM and HAA5 must be complied with as a locational running annual average (LRAA) at each monitoring location beginning the date specified for Stage 2 Disinfection Byproducts Requirements (LRAA) compliance in subparagraph (1)(c) of Rule 0400-45-01-.38.

Disinfection by-product	MCL (mg/L)
Total trihalomethanes (TTHM)	0.080
Haloacetic acids (five) (HAA5)	0.060

- (ii) The Administrator, pursuant to section 1412 of the Federal Safe Drinking Water Act, hereby identifies the following as the best technology, treatment techniques, or other means available for achieving compliance with the maximum contaminant levels for TTHM and HAA5 identified in this part for all systems that disinfect their source water:

Disinfection by-product	Best available technology
Total trihalomethanes (TTHM) and Haloacetic acids (five) (HAA5)	Enhanced coagulation or enhanced softening or GAC10; nanofiltration and with a molecular weight cutoff of equal to or less than 1000 Daltons; or GAC20

- (iii) The Administrator, pursuant to section 1412 of the Federal Safe Drinking Water Act, hereby identifies the following as the best technology, treatment techniques, or other means available for achieving compliance with the maximum contaminant levels for TTHM and HAA5 identified in this part for consecutive systems and applies only to the disinfected water that consecutive systems buy or otherwise receive:

Disinfection by-product	Best available technology
Total trihalomethanes (TTHM) and	Systems serving 10,000 or more:

(Rule 0400-45-01-.06, continued)

Haloacetic acids (five) - (HAA5).	<p>Improved distribution system and storage tank management to reduce residence time, plus the use of chloramines for disinfectant residual maintenance.</p> <p>Systems serving &lt;10,000: Improved distribution system and storage tank management to reduce residence time.</p>
-----------------------------------	------------------------------------------------------------------------------------------------------------------------------------------------------------------------------------------------------------------------------------------------------------------------------------

(c) Maximum residual disinfectant levels.

1. Maximum residual disinfectant levels (MRDLs) are as follows:

Disinfectant residual	MRDL (mg/L)
Chlorine.....	4.0 (as Cl <sub>2</sub> ).
Chloramines.....	4.0 (as Cl <sub>2</sub> ).
Chlorine dioxide.....	0.8 (as ClO <sub>2</sub> ).

(d) Compliance dates.

1. CWSs and NTNCWSs. Subpart H systems serving 10,000 or more persons must comply with MRDLs beginning January 1, 2002. Subpart H systems serving fewer than 10,000 persons and systems using only ground water not under the direct influence of surface water must comply with MRDLs beginning January 1, 2004.
2. Transient NCWSs. Subpart H systems serving 10,000 or more persons and using chlorine dioxide as a disinfectant or oxidant must comply with the chlorine dioxide MRDL beginning January 1, 2002. Subpart H systems serving fewer than 10,000 persons and using chlorine dioxide as a disinfectant or oxidant and systems using only ground water not under the direct influence of surface water and using chlorine dioxide as a disinfectant or oxidant must comply with the chlorine dioxide MRDL beginning January 1, 2004.

(e) Best Available Control Technology

1. The following are identified as the best technology, treatment technology or other means available for achieving compliance with the maximum residual disinfectant level:
  - (i) Control of the treatment processes to reduce disinfectant demand and control of disinfection treatment processes to reduce disinfectant levels.

**Authority:** T.C.A. §§ 4-5-201, et seq. and 68-221-701, et seq. **Administrative History:** Original rule filed August 1, 2012; effective October 30, 2012. Rule was previously numbered 1200-05-01. Amendments and new rules filed November 24, 2015; effective February 22, 2016. Amendments filed March 7, 2016; effective June 5, 2016.

**0400-45-01-.07 MONITORING AND ANALYTICAL REQUIREMENTS.**

(1) Microbiological Contaminant Sampling

- (a) Effective April 1, 2016, violations for total coliform and fecal coliform shall no longer be considered MCL violations and violations regarding total coliform shall be treatment



(Rule 0400-45-01-.07, continued)

technique triggers as described in Rule 0400-45-01-.41. Paragraph (5) of this rule further delineates the transition to Rule 0400-45-01-.41.

- (b) Reserved
- (c) The supplier of water for a community water system shall take coliform samples at regular time intervals and in number proportional to the population served by the system during the reporting period as set forth below:

TOTAL COLIFORM MONITORING FREQUENCY FOR COMMUNITY WATER SYSTEMS

<u>Population Served</u>	<u>Minimum Number of Samples Per Month</u>
25 to 1,000 <sup>1</sup> .....	1
1,001 to 2,500 .....	2
2,501 to 3,300 .....	3
3,301 to 4,100 .....	4
4,101 to 4,900 .....	5
4,901 to 5,800 .....	6

<u>Population Served</u>	<u>Minimum Number of Samples Per Month</u>
5,801 to 6,700 .....	7
6,701 to 7,600 .....	8
7,601 to 8,500 .....	9
8,501 to 12,900 .....	10
12,901 to 17,200 .....	15
17,201 to 21,500 .....	20
21,501 to 25,000 .....	25
25,001 to 33,000 .....	30
33,001 to 41,000 .....	40
41,001 to 50,000 .....	50
50,001 to 59,000 .....	60
59,001 to 70,000 .....	70
70,001 to 83,000 .....	80
83,001 to 96,000 .....	90
96,001 to 130,000 .....	100
130,001 to 220,000 .....	120
220,001 to 320,000 .....	150
320,001 to 450,000 .....	180
450,001 to 600,000 .....	210
600,001 to 780,000 .....	240
780,001 to 970,000 .....	270
970,001 to 1,230,000 .....	300
1,230,001 to 1,520,000 .....	330
1,520,001 to 1,850,000 .....	360
1,850,001 to 2,270,000 .....	390
2,270,001 to 3,020,000 .....	420
3,020,001 to 3,960,000 .....	450
3,960,001 or more .....	480

(Rule 0400-45-01-.07, continued)

of the first exceedance, unless the Department determines that the system, for reasons outside the system's control cannot have the sample analyzed within 30 hours of collection. Sample results from this coliform monitoring must be included in determining compliance with the MCL for total coliforms in paragraph (4) of Rule 0400-45-01-.06.

- (g) Special purpose samples, such as those taken to determine whether disinfection practices are sufficient following pipe placement, replacement, or repair, shall not be used to determine whether the coliform treatment technique trigger has been exceeded compliance with the MCL for total coliforms in paragraph (4) of Rule 0400-45-01-.06 provided the water is not served to customers before negative analytical results are obtained. Samples representing water served to customers prior to obtaining analytical results shall not be special purpose samples and shall not count toward compliance with the MCL for total coliforms in paragraph (4) of Rule 0400-45-01-.06 with the MCL for total coliforms in paragraph (4) of Rule 0400-45-01-.06. After March 31, 2016, this subparagraph is no longer applicable.

(2) Repeat Monitoring

- (a) If a routine sample is total coliform-positive, the public water system must collect a set of repeat samples within 24 hours of being notified of the positive result. A system which collects more than one routine sample per month must collect no fewer than three repeat samples for each total coliform-positive sample found. A system which collects one routine sample per month or fewer must collect no fewer than four repeat samples for each total coliform-positive sample found. The Department may extend the 24-hour limit on a case-by-case basis if the system has a problem in collecting the repeat samples within 24 hours that is beyond its control. In the case of an extension, the Department must specify how much time the system has to collect the repeat samples.
- (b) The system must collect at least one repeat sample from the sampling tap where the original total coliform-positive sample was taken, and at least one repeat sample at a tap within five service connections upstream and at least one repeat sample at a tap within five service connections downstream of the original sampling site. If a total coliform-positive sample is at the end of the distribution system, or one away from the end of the distribution system, the Department may waive the requirement to collect at least one repeat sample upstream or downstream of the original sampling site.
- (c) The system must collect all repeat samples on the same day and within 24 hours of being notified of a positive result, except that the Department may allow a system with a single service connection to collect the required set of repeat samples over a four consecutive day period or to collect a larger volume repeat sample(s) in one or more sample containers of any size, as long as the total volume collected is at least 400 ml (300 ml for systems which collect more than one routine sample per month.)
- (d) If one or more repeat samples in the set is total coliform-positive, the public water system must collect an additional set of repeat samples in the manner specified in subparagraphs (a), (b), and (c) of this paragraph. The additional samples must be collected within 24 hours of being notified of the positive result, unless the Department extends the limit as provided in subparagraph (a) of this paragraph. The system must repeat this process until either total coliforms are not detected in one complete set of repeat samples or the system determines that the MCL for total coliforms in paragraph (4) of Rule 0400-45-01-.06 has been exceeded and notifies the Department.
- (e) If a system normally collecting fewer than five routine samples per monitoring period has one or more total coliform-positive samples and the Department does not

(Rule 0400-45-01-.11, continued)

1. The Department may require more frequent monitoring than specified in subparagraphs (a) and (b) of this paragraph, or may require confirmation samples at its discretion. The results of the initial and confirmation samples will be averaged for use in compliance determinations.
2. Each public water systems shall monitor at the time designated by the Department during each compliance period.
3. Compliance: Compliance the radionuclide MCLs will be determined based on the analytical result(s) obtained at each sampling point. If one sampling point is in violation of an MCL, the system is in violation of the MCL.
  - (i) For systems monitoring more than once per year, compliance with the MCL is determined by a running annual average at each sampling point. If the average of any sampling point is greater than the MCL, then the system is out of compliance with the MCL.
  - (ii) For systems monitoring more than once per year, if any sample result will cause the running average to exceed the MCL at any sample point, the system is out of compliance with the MCL immediately.
  - (iii) Systems must include all samples taken and analyzed under the provisions of this Rule in determining compliance, even if that number is greater than the minimum required.
  - (iv) If a system does not collect all required samples when compliance is based on a running annual average of quarterly samples, compliance will be based on the running average of the samples collected.
  - (v) If a sample result is less than the detection limit, zero will be used to calculate the annual average, unless a gross alpha particle activity is being used in lieu of radium-226 and/or uranium. If the gross alpha particle activity result is less than detection, 1/2 the detection limit will be used to calculate the annual average.
4. The Department has the discretion to delete results of obvious sampling or analytic errors.
5. If the MCL for radioactivity set forth in paragraph (5) of Rule 0400-45-01-.06 is exceeded, the operator of a community water system must give notice to the Department pursuant to Rule 0400-45-01-.20 and to the public as required by Rule 0400-45-01-.19.

**Authority:** T.C.A. §§ 4-5-201, et seq. and 68-221-701, et seq. **Administrative History:** Original rule filed August 1, 2012; effective October 30, 2012. Rule was previously numbered 1200-05-01.

#### **0400-45-01-.12 SECONDARY DRINKING WATER REGULATIONS.**

- (1) The following maximum contaminant levels are established to provide a water that is aesthetically pleasing to the consumer. These standards will apply to all community water systems and to those non-community water systems as may be deemed necessary by the Department. Monitoring for these contaminants will be set in the Monitoring Program for each system, but in no event less than once every year for a surface and surface/ground supply and once every three years for a ground water supply.

#### Maximum Contaminant Level

(Rule 0400-45-01-.12, continued)

<u>Contaminant</u>	<u>Milligrams per Liter (unless otherwise indicated)</u>
(a) Chloride	250
(b) Color	15 (Color Units)
(c) Copper	1
(d) MBAS (Methyl Blue Active Substance)	0.5
(e) Iron	0.3
(f) Manganese	0.05
(g) Odor	3 (Threshold Odor Number)
(h) pH	6.5-8.5
(i) Sulfate	250
(j) TDS (Total Dissolved Solids)	500
(k) Zinc	5
(l) Fluoride	2
(m) Aluminum	0.2
(n) Silver	0.1

(2) The system may apply for monitoring waivers from the monitoring frequency specified in paragraph (1) of this rule. The Department may issue monitoring waivers after considering: historical data, whether or not there have been customer complaints concerning the contaminant to be waived, any corrective action taken by the water supplier to correct the secondary contaminant problem, and whether or not the system routinely monitors for the contaminant as part of its treatment process monitoring program. The Department shall determine the frequency, if any, a system must monitor after considering the historical data available, the number and nature of customer complaints and other factors that may affect the contaminant concentration, and specify the decision in writing to the system.

**Authority:** T.C.A. §§ 4-5-201, et seq. and 68-221-701, et seq. **Administrative History:** Original rule filed August 1, 2012; effective October 30, 2012. Rule was previously numbered 1200-05-01.

**0400-45-01-.13 ALTERNATIVE ANALYTICAL TECHNIQUES.**

If an alternative analytical technique is acceptable to the Administrator of the U.S. Environmental Protection Agency as being substantially equivalent to the prescribed test in both precision and accuracy as it relates to the determination of compliance with any maximum contaminant level, they shall become a part of these rules and regulations by inference.

**Authority:** T.C.A. §§ 4-5-201, et seq. and 68-221-701, et seq. **Administrative History:** Original rule filed August 1, 2012; effective October 30, 2012. Rule was previously numbered 1200-05-01.

(Rule 0400-45-01-.15, continued)

by the Environmental Protection Agency will have compliance with the MCL determined on the analytical results of its sampling.

- (3) Those public water systems which purchase all their water and elect to use the analytical results of the system from which it purchases water shall be deemed to be in compliance with the monitoring and MCL requirements provided the seller of water is in compliance. Any violation of an MCL or monitoring requirement by the seller of water will constitute a violation for all systems which purchase water unless samples are taken as described in paragraph (2) of this rule.
- (4) All public notification requirements as contained in Rule 0400-45-01-.19 are the responsibility of the individual public water system regardless of which public water system conducts the analysis.
- (5) All public water systems must maintain records as required by Rule 0400-45-01-.20 of all analytical results which pertain to the system regardless of which system actually did the analysis.

**Authority:** T.C.A. §§ 4-5-201, et seq. and 68-221-701, et seq. **Administrative History:** Original rule filed August 1, 2012; effective October 30, 2012. Rule was previously numbered 1200-05-01.

#### **0400-45-01-.16 SITING REQUIREMENTS.**

- (1) Before a person may enter into a financial commitment for or initiate construction of a new public water system or increase capacity of an existing public water system, he shall notify the Department and, to the extent practicable, avoid locating part or all of the new or expanded facility at a site which:
  - (a) Is subject to a significant risk from earthquakes, floods, fires, or other disasters which could cause a breakdown of the public water system or a portion thereof; or
  - (b) Except for intake structures, is within the flood plain of a 100-years flood.
- (2) All other siting requirements shall be in accordance with those set forth in "Design Criteria for Public Water Systems" as published by the Department.

**Authority:** T.C.A. §§ 4-5-201, et seq. and 68-221-701, et seq. **Administrative History:** Original rule filed August 1, 2012; effective October 30, 2012. Rule was previously numbered 1200-05-01.

#### **0400-45-01-.17 OPERATION AND MAINTENANCE REQUIREMENTS.**

- (1) (a) All community water systems which are designated as a surface supply or groundwater under the direct influence of surface water and classified as a filtration system and all iron removal plants which use gravity filters must have an operator in attendance and responsible for the treatment process when the plant is in operation. Gravity iron removal plants and groundwater under the direct influence of surface water filtration plants which have installed continuous monitoring equipment including equipment for turbidity and chlorine residual with alarms and/or shutdown ability may seek written approval from the Department to operate the treatment plant in an automated mode without an operator in attendance. All iron removal plants with pressure filters and using a groundwater source from an approved sand and gravel formation will not be required to have an operator in attendance during all periods of operation provided suitable protection, acceptable to the Department, is provided.

(Rule 0400-45-01-.17, continued)

- (b) Non-community water systems which are classified as a surface supply will be required to have a full time operator in attendance unless certain continuous monitoring equipment is installed.
  - (c) Pursuant to T.C.A. § 68-221-904, all operators in direct responsible charge of a water supply system, including the treatment plant and/or distribution system, must be certified by the Department as competent to operate the water supply system.
  - (d) Because the proper operation and maintenance of water systems is critical to a system's ability to provide safe water to the public and to comply with these rules, all water supply systems must comply with the provisions of Chapter 0400-49-01. A violation of those rules is a violation of this rule as well.
- (2) (a) All community water systems and those non-community water systems classified as a surface source shall compile and maintain accurate daily operating records of the water works system on forms prepared and furnished by the Department. The daily operating records shall be submitted in a timely manner so they are received by the Department no later than ten days after the end of the reporting month. Any special reports, deemed necessary by the Department to assure continuous satisfactory operation of the water system, shall be submitted to the Department.
  - (b) Water systems which desire to use their own forms to report the daily operating results to the Department must have prior written approval of the form from the Department.
- (3) All water quality tests, other than those listed in Rule 0400-45-01-.06 shall be made in accordance with the latest edition of "Standard Methods for the Examination of Water and Wastewater" or alternate methods acceptable to the Department. The schedule of laboratory tests followed in controlling the operation of a waterworks system will vary with the character of the water; therefore, all waterworks systems must have the equipment necessary to perform all laboratory tests pertinent to the control of the plant or system operation, and the equipment shall be maintained in good working order at all times. Laboratory tests pertinent to proper operation shall be prescribed by the Department for each community water system.
  - (4) Chlorine is the recommended disinfection agent. Other agents will be considered by the Department provided they are effective and testing procedures for their effectiveness are recognized in the latest edition of "Standard Methods for the Examination of Water and Wastewater". All community water systems, using ground water as a raw water source and serving more than 50 connections or 150 persons shall continuously chlorinate (unless other disinfection methods are approved) and shall maintain a free chlorine residual in all parts of the distribution system in the amount of not less than 0.2 mg/l. Public Water Systems using surface water shall continuously chlorinate and maintain a free chlorine residual of 0.2 mg/l in all parts of the distribution system. The residual disinfectant concentration specified by this rule shall not be less than 0.2 mg/l in more than 5 percent of the samples each month, for any two consecutive months the system serves water to the public. All public water systems serving 50 or fewer connections that do not disinfect shall install continuous disinfection if the system fails to comply with the maximum contaminant level for coliform, experiences a disease outbreak or is directed to install disinfection by the department.
  - (5) All systems submitting samples for microbiological examination to the State laboratory must submit said sample in the bottle(s) provided by the State and return the samples to the proper State laboratory in the shipping carton provided by the State. The cost of postage for shipping the sample to the proper State laboratory shall be paid by the supplier of water. All samples submitted for microbiological examination must be collected and mailed to arrive at the proper State laboratory not later than Thursday noon of any week. Thirty hours is the limit allowed from the time of collection to the time of examination at the proper state laboratory.

(Rule 0400-45-01-.17, continued)

- (6) (a) Pursuant to T.C.A. § 68-221-711(6), the installation, allowing the installation, or maintenance of any cross-connection, auxiliary intake, or bypass is prohibited unless the source and quality of water from the auxiliary supply, the method of connection, and the use and operation of such cross-connection, auxiliary intake, or bypass has been approved by the Department. The arrangement of sewer, soil, or other drain lines or conduits carrying sewage or other wastes in such a manner that the sewage or waste may find its way into any part of the public water system is prohibited.
- (b) 1. All community water systems must adopt an ordinance or policy outlining the prohibitions in subparagraph (a) of this paragraph and submit a copy of the executed ordinance or policy to the Department for written approval. All community water systems shall develop a written plan for a cross-connection control program to detect and eliminate or protect the system from hazards associated with cross-connections. The written plan must be approved by the Department.
2. After adoption and approval of the cross-connection ordinance or policy and plan, each community water system must establish an ongoing program to detect and eliminate or protect the system from hazards associated with cross-connections. Records of the cross-connection control program must be maintained by the supplier of water and shall include such items as date of inspection, person contacted, recommendations, follow-up, and testing results.
3. Cross-connection plans and policies shall present information in conformance with the "Cross-Connection Control Manual and Design Criteria for Cross-Connection Control Plans, Ordinances and Policies" as published by the Department.
4. Community water systems shall ensure that cross-connections between the distribution system and a consumer's plumbing are surveyed and/or inspected and determined not to exist or contain a significant risk or are eliminated or controlled by the installation of an approved backflow preventer commensurate with the degree of hazard.
5. Non-community water systems shall ensure that unprotected cross-connections are not allowed to exist within the water system. The non-community water system shall conduct periodic inspections of the water system and maintain a statement of inspection completion to include acknowledgement of the hazards associated with cross-connections.
- (7) All community water systems shall prepare and maintain an emergency operations plan in order to safeguard the water supply and to alert the public of unsafe drinking water in the event of natural or man-made disasters. Emergency operation plans shall be consistent with guidelines established by the Department and shall be reviewed and approved in writing by the Department. Systems shall include a drought management plan as a part of the emergency operations plan. The emergency operations plan, including the drought management portion, shall be reviewed, updated, and submitted to the Department at least once every three years. The drought management plan portions of the emergency operations shall be submitted for approval as follows:
- (a) Systems serving 3,000 or more connections including consecutive systems: June 30, 2016.
- (b) Systems serving more than 1,000 connections and less than 3,000 connections including consecutive systems: June 30, 2017.

(Rule 0400-45-01-.17, continued)

- (c) Systems serving 1,000 connections or less: June 30, 2018.
- (8) (a) General-Public water systems, construction contractors, and engineers shall follow and document sanitary practices used in inspecting, constructing or repairing water lines, finished water storage facilities, water treatment facilities, and wells. Public water systems, construction contractors, and engineers shall follow the latest edition of the AWWA standards C-651, C-652, C-653, C-654, or equivalent methods provided the method has been approved in writing by the Department and is available during the inspection, construction, maintenance, or repair activity. In lieu of following AWWA standards or approved equivalent methods, public water systems, construction contractors, and engineers may write their own disinfection standard operating procedures. Disinfection standard operating procedures shall be approved in writing by the Department and be available during the inspection, construction, maintenance, or repair activity.

The documentation shall include disinfection procedures used, bacteriological sample results, construction logs, and repair logs and may include photographs where appropriate. All wells, pipes, tanks, filters, filter media and other materials shall be properly disinfected prior to being placed in service. Any disinfectant used to disinfect shall be NSF approved or plain household bleach and used in a manner that assures sufficient contact time and concentration to inactivate any pathogens present. Bacteriological results including line repair records indicating adequacy of disinfection shall be maintained on file by the public water system for five years. Procedures to ensure that water containing excessive concentrations of disinfectant is not supplied to the customers or discharged in such manner as to harm the environment shall be implemented.

All materials used for new or repaired water lines, storage facilities, water treatment facilities, and wells will be inspected prior to use for any evidence of gross contamination. Any contamination observed shall be removed and the materials protected during installation.

- (b) Bacteriological Sampling of New Facilities-Bacteriological samples will be collected and analyzed to verify the effectiveness of the disinfection practices prior to placing new facilities in service. Bacteriological samples for finished water storage facilities, water treatment facilities, and wells shall be collected as specified by AWWA standards C-652, C-653, and C-654.

Adequacy of disinfection of new lines shall be demonstrated by collecting two sets of microbiological samples 24 hours apart or collecting a single set of microbiological samples 48 hours or longer after flushing the highly chlorinated water from the lines. In either case microbiological samples in each set will be collected at approximately 2,500-foot intervals with samples near the beginning point, the end point, and at the end of each branch line, unless written approval of alternate sampling frequency and distance between sampling points has been obtained from the Department. If the newly constructed facility yields positive bacterial samples, the line shall be flushed, and re-sampled. If subsequent samples are positive, the line shall be re-disinfected, flushed and sampled again.

- (c) Bacteriological Sampling of Existing Facilities
1. Finished water storage facilities, water treatment facilities, and wells that have been compromised and potential contamination is introduced during inspection or repair shall be disinfected, flushed, and sampled as specified by AWWA standards C-652, C-653, and C-654. Bacteriological samples shall be collected from a location representing the water contained in the compromised facility. The



(Rule 0400-45-01-.17, continued)

- repaired facility may be returned to service prior to obtaining bacteriological results.
2. Drinking water mains where positive pressure has not been maintained during inspection or repair shall be disinfected and flushed prior to being placed back in service. Disinfection and flushing shall be in accordance with AWWA standard C-651 or other method approved in writing by the Department. Bacteriological samples shall be collected immediately after the repair is completed and from a location representing the water contained in the repaired main. The repaired main may be returned to service prior to obtaining bacteriological results. If the repaired main has been placed back into service and yields positive bacteriological samples, the main shall be flushed and re-sampled. One sample is to be collected at the original positive site, one sample is to be collected upstream of the repair and one sample is to be collected in the downstream area of the repair. Sampling shall continue until the water is coliform free.
  3. If one-half or more of the bacteriological samples collected from the repaired facility are total coliform positive, the system shall notify the Department within 30 days that it has reviewed its disinfection and sampling practices in an attempt to identify why the positive samples occurred and revise its disinfection and sampling plans accordingly.
  4. If any public water system collects a fecal coliform positive repeat sample or E-coli positive repeat sample or a total coliform positive repeat sample following an initial positive fecal coliform or E-coli sample collected from the repaired facility, the system shall notify the Department within 24 hours and issue a Tier 1 public notice using the language specified in Appendix B of Rule 0400-45-01-.19.
- (d) Inspectors, contractors, operators, public water systems or engineers that fail to document and follow adequate disinfection procedures, and fail to collect bacteriological samples during repairs, inspections or maintenance activities that potentially would compromise the microbial quality of the water shall issue a boil water advisory to the customers served by that portion of the public water system prior to returning the facility to service. The boil water advisory shall remain in effect until satisfactory microbial tests results and written approval from the Department are obtained.
- (9) All community water systems shall be operated and maintained to provide minimum positive pressure of twenty (20) psi throughout the distribution system. No person shall install or maintain a water service connection to any premises where a booster pump has been installed unless such booster pump is equipped with a low pressure cut-off mechanism designed to cut off the booster pump when the pressure on the suction side of the pump drops to twenty (20) psi gauge.
  - (10) All community water systems having more than 50 service connections shall establish and maintain an adequate flushing program. The flushing program established shall help ensure that dead end and low usage mains are flushed periodically, drinking water standards are met, sediment and air removal and the free chlorine residual specified under paragraph (4) of this rule is maintained. Records of each flushing are to be maintained by the water system. These records shall include date, time, location, persons responsible and length of flushing. In addition to the above information, the free chlorine residual will have to be measured and recorded on the end of dead end mains after being flushed.
  - (11) All community public water systems serving more than 50 connections and which have their own source of water shall be required to install, operate and maintain duplicate disinfection equipment. Duplicate disinfection equipment means at least two chlorine cylinders connected

(Rule 0400-45-01-.17, continued)

use only. All community public water systems using ground water supplies and having more than 50 service connections must have duplicate wells and/or duplicate pumps in a spring supply unless fed by gravity flow.

- (14) All community water systems serving 50 connections or more are required to have 24 hours of distribution storage based on the average daily demand for the past twelve months. Distribution storage must be located so that the instantaneous demand can be met in all areas at any time.
- (a) Systems which purchase water for resale may utilize the storage of the supplier provided the supplier has adequate distribution storage. Water systems that have large ground storage tanks will be given credit for distribution storage provided auxiliary power is available to pump water to the distribution system.
  - (b) Systems which have more than three (3) treatment facilities, have more than one source of water, and which have special power arrangements so that it is unlikely that all units would be down at the same time are not required to have distribution storage provided the peak demand can be met.
  - (c) Water systems which have an average daily demand of 10 million gallons or more are not required to have 24 hours of distribution storage provided the system has adopted a contingency plan for emergencies that has been approved by the Department. The contingency plan must demonstrate the water system is able to provide residential service to all customers for a 24 hour period during any emergency involving the shut down of the treatment facility.
  - (d) Public water systems which utilize wells and provide only disinfection, pH adjustment, corrosion inhibitor and/or fluoridation as treatment, may use the capacity of the wells and the plant as part of the distribution storage under the following conditions:
    - 1. The existing distribution storage tank(s) are adequate to meet the peak demands on the system,
    - 2. The well(s), disinfection equipment and other pumping facilities needed to supply water to the distribution storage tank are equipped with an auxiliary power source with automatic controls, and
    - 3. The well field capacity is determined by removing the largest well from consideration.
  - (e) Public water systems may take into account private distribution storage facilities in the following manner:
    - 1. Private distribution storage may be counted as water system storage provided the private storage tank floats on the water utility's system and the water used serves both the private and utility system demand.
    - 2. The water utility may reduce the amount of needed distribution storage by subtracting the average daily volume of any water user that has its own storage tank. This can be done provided the private storage tank is used on a daily basis.
    - 3. Private distribution storage tanks used strictly for fire protection by the private owner cannot be in the water systems distribution storage capacity.
- (15) All community water systems serving 50 or more service connections must have and maintain up-to-date maps of the distribution system. These maps must show the locations of

(Rule 0400-45-01-.17, continued)

the water mains, sizes of mains, valves, blow-offs or flush hydrants, air-release valves, and fire hydrants. One up-to-date copy of the overall system distribution map(s) is to be submitted to the Division of Water Resources every five years.

- (16) All vents on wells, springs, storage tanks, overflows and clearwells shall be properly screened. All overflows on springs and tanks shall be screened and protected.
- (17) All buildings and equipment used in and for the production and distribution of water (to include chemical and other storage buildings) must be well maintained and be reliable and fit for the purpose for which they are used. This includes, but is not limited to:
  - (a) When a water treatment plant is not producing water and an operator is not in attendance, plant entrances must be locked.
  - (b) Equipment such as chemical feeders, pumps, turbidimeters, pumpage meters, alarm systems, and air tanks shall be maintained and in good working condition. Pumps, tanks, hoses, and other equipment used by system personnel shall be disinfected and dedicated to its use if it comes into contact with water that may be consumed by humans.
  - (c) Duplicate or backup equipment shall be available as necessary to maintain the production of water meeting drinking water standards. Backup equipment or alternate treatment means shall be available for feeding all chemicals critical for adequate water treatment.
- (18) All community water systems planning to or having installed hydrants must protect the distribution system from contamination. All water mains designed for fire protection must be six inches or larger and be able to provide 500 gallons per minute with 20 pounds per square inch residual pressure. Fire hydrants shall not be installed on water mains less than six inches in diameter or on water mains that cannot produce 500 gpm at 20 psi residual pressure unless the tops are painted red. Out of service hydrants shall have tops painted black or covered with a black shroud or tape.

Existing Class C hydrants (hydrants unable to deliver a flow of 500 gallons per minute at a residual pressure of 20 pounds per square inch (psi) shall have their tops painted red by January 1, 2008.

The water system must provide notification by certified mail at least once every five years beginning January 1, 2008, to each fire department that may have reason to utilize the hydrants, that fire hydrants with tops painted red (Class C hydrants) cannot be connected directly to a pumper fire truck. Fire Departments may be allowed to fill the booster tanks on any fire apparatus from an available hydrant by using the water system's available pressure only (fire pumps shall not be engaged during refill operations from a Class C hydrant).

- (19) Before any new or modified community water treatment facility can be placed in service, it must be inspected and approved in writing by the Department.
- (20) Each public water system adjusting the fluoride content to the finished water must monitor for fluoride quarterly using a certified laboratory and the calculation of the fluoride level will be by running annual average. If the quarterly analysis of a water sample from a public water system by a certified laboratory confirms that the level of fluoride in the sample exceeds 1.5 mg/L, the public water system must provide notification to its customers of the exceedance in the same manner as prescribed in paragraph (8) of Rule 0400-45-01-.19. The water system must begin monthly fluoride monitoring using a certified laboratory for analysis. Once the monthly analyses confirm that the fluoride level is less than 1.5 mg/L for three (3) consecutive months, the public water system may resume quarterly monitoring for fluoride.

(Rule 0400-45-01-.17, continued)

The recommended level of fluoridation in the finished water is 0.7 mg/l. Any public water system which determines to initiate or permanently cease fluoridation treatment of its water supply shall notify its customers, the local environmental field office within the Department of Environment and Conversation, and the Commissioner of the Department of Health in the manner and within the timeframe as specified by T.C.A. § 68-221-708(c).

- (21) New or modified turbidity removal facilities may not be placed into operation until the facility and the operator have been approved by the Department for the turbidity analysis.
- (22) All pipe, pipe or plumbing fitting or fixture, solder, or flux which is used in the installation or repair of any public water system shall be lead free. The term "lead free" shall have the meaning given it in T.C.A. § 68-221-703.
- (23) All dead end water mains and all low points in water mains shall be equipped with a blow-off or other suitable flushing mechanism capable of producing velocities adequate to flush the main.
- (24) All community water systems must establish and maintain a file for customer complaints. This file shall contain the name of the person with the complaint, date, nature of complaint, date of investigation and results or actions taken to correct any problems.
- (25) The Department may, upon written notice, require confirmation of any sampling results and also may require sampling and analysis for any contaminant when deemed necessary by the Department to protect the public health or welfare.
- (26) Those public water systems required to monitor for turbidity and chlorine residual must have the laboratory approved by the Department before the results of these analyses can be accepted for compliance purposes.
- (27) By December 30, 1991, or 18 months after the determination that a ground water system is influenced by surface water, all public water systems classified as a ground water system impacted by surface water shall utilize treatment techniques which achieve:
  - (a) At least 99.9 percent (3 log) removal and/or inactivation of *Giardia lamblia* cysts between a point where the raw water is not subject to recontamination by surface water runoff and a point downstream before or at the first customer.
  - (b) At least 99.99 percent (4 log) removal and/or inactivation of viruses between a point where the raw water is not subject to recontamination by surface water runoff and a point downstream before or at the first customer.
- (28) All public water systems using surface water shall provide disinfection to control the biological quality of the water. Due consideration shall be given to the contact time of the disinfectant in the water with relation to pH, ammonia, taste producing substances, temperature, presence and type of pathogens, and trihalomethane formation potential. All disinfection basins must be designed to prevent water short-circuiting the system. The disinfectant will be applied in the manner needed to provide adequate contact time.
- (29) All community water systems using ground water as the raw water source serving water to more than 50 connections or 150 people will apply the disinfectant in the manner needed for adequate contact time. Contact time for ground water systems shall not be less than 15 minutes prior to the first customer.
- (30) Any surface supplied public water system or ground water systems under the direct influence of surface water required to filter shall employ filtration in combination with disinfection that

(Rule 0400-45-01-.17, continued)

- (32) New service taps on existing mains that must be uncovered to make the tap, shall be flushed and the free chlorine residual measured and recorded prior to connecting the service lines. These records shall be retained until the next sanitary survey or for three years.
- (33) All public water systems shall properly maintain their distribution system finished water storage tanks and clearwells. Each community water system shall establish and maintain a maintenance file on each of its distribution storage tanks and clearwells. These maintenance files must be available for inspection by Department personnel. These files must include records of all routine water storage tank and clearwell inspections by system personnel, any reports of detailed professional inspections of the water storage facilities by contractor personnel, dates and details of routine tank cleanings and surface flushings, and dates and details of all tank and clearwell maintenance activities. The tank and clearwell inspection records shall include dates of the inspections; the sanitary, coating and structural conditions of the water storage facility; and all recommendations for needed maintenance activities. Community water systems shall have a professional inspection performed and a written report produced on each of their distribution storage tanks and clearwells at least once every five years. Non-community water systems shall have a professional inspection performed and written report produced on each of their atmospheric pressure and distribution storage tanks and clearwells no less frequently than every five years. Records of these inspections shall be available to the Department personnel for inspection. Persons conducting underwater inspections of distribution system finished water storage tanks and clearwells shall comply with AWWA standard C-652-11 or later versions of the standard.
- (34) Paints and coatings for the interior of potable water storage facilities must be acceptable to the Department. Paints and coatings accepted by the Environmental Protection Agency (EPA) and/or the National Sanitation Foundation (NSF) for potable water contact are generally acceptable to the Department. Paint systems for steel tanks shall be consistent with AWWA Standard D102-78. Factory coated bolted steel tanks shall be in accordance with AWWA D103-87. Wire-wound circular prestressed concrete tanks shall be in accordance with AWWA D110-86.
- (35) By January 1, 1996, public water systems using surface water and ground water systems under the direct influence of surface water that filter shall have rewash capability. Such systems shall perform a rewash cycle, or filter to waste each time a filter is backwashed. The rewash cycle shall be conducted in a way and manner necessary to prevent the introduction of contaminants such as pathogens and turbidity trapped in the filter into the clear well or distribution system.

Existing filter plants may be approved to operate without rewash (filter-to-waste provisions) if existing operational and backwash practices prevent water of unacceptable quality from entering the clearwell or distribution system. To operate without rewash the water system must demonstrate to the Department that filtered water turbidity after backwashing is reliably and consistently below 0.5 NTU immediately after backwashing each filter. Approval to operate without rewash must be approved in writing and approval must be renewed if any modifications are made to the operation or design of the plant. Each filter that operates without rewash must have a continuous recording turbidimeter and retain the records for a period of five years.

- (36) By January 1, 1995, all chemicals, additives, coatings or other materials used in the treatment, conditioning and conveyance of drinking water must have been approved by the National Sanitation Foundation (NSF) or American National Standards Institute (ANSI) certified parties as meeting NSF product standard 60 and 61. Until 1995, products used for treatment, conditioning and conveyance of drinking water shall have been listed as approved by the US EPA or NSF.

(Rule 0400-45-01-.19, continued)

Table 0400-45-01-.19(1)(a)

Violation Categories and Other Situations  
Requiring a Public Notice

- 
1. NPDWR violations:
    - (i) Failure to comply with an applicable maximum contaminant level (MCL) or maximum residual disinfectant level (MRDL).
    - (ii) Failure to comply with a prescribed treatment technique (TT).
    - (iii) Failure to perform water quality monitoring, as required by the drinking water regulations.
    - (iv) Failure to comply with testing procedures as prescribed by a drinking water regulation.
  2. Variance and exemptions under sections 1415 and 1416 of SDWA:
    - (i) Operation under a variance or an exemption.
    - (ii) Failure to comply with the requirements of any schedule that has been set under a variance or exemption.
  3. Special public notices:
    - (i) Occurrence of a waterborne disease outbreak or other waterborne emergency.
    - (ii) Exceedance of the alternate MCL for nitrate by non-community water systems (NCWS), where the non-community system has been granted an alternate standard by the department.
    - (iii) Exceedance of the secondary maximum contaminant level (SMCL) for fluoride.
    - (iv) Availability of unregulated contaminant monitoring data.
    - (v) Other violations and situations determined by the department to require a public notice under this rule, not already listed in Appendix A.

- 
- (b) Public notice requirements are divided into three tiers to take into account the seriousness of the violation or situation and any potential adverse health effects that may be involved. The public notice requirements for each violation or situation listed in Table 0400-45-01-.19(1)(a) are determined by the tier to which it is assigned. Table 0400-45-01-.19(1)(b) provides the definition of each tier. Appendix A of this rule identifies the tier assignment for each specific violation or situation.

Table 0400-45-01-.19(1)(b)

Definition of Public Notice Tiers

- 
1. Tier 1 public notice—required for NPDWR violations and situations with significant potential to have serious adverse effects on human health as a result of short-term exposure.
  2. Tier 2 public notice—required for all other NPDWR violations and situations with potential to have serious adverse effects on human health.
  3. Tier 3 public notice—required for all other NPDWR violations and situations not included in Tier 1 and Tier 2.

- 
- (c) Who must be notified?

(Rule 0400-45-01-.19, continued)

1. Each public water system must provide public notice to persons served by the water system, in accordance with this rule. Public water systems that sell or otherwise provide drinking water to other public water systems (i.e., to consecutive systems) are required to give public notice to the owner or operator of the consecutive system; the consecutive system is responsible for providing public notice to the persons it serves.
  2. If a public water system has a violation in a portion of the distribution system that is physically or hydraulically isolated from other parts of the distribution system, the Department may allow the system to limit distribution of the public notice to only persons served by that portion of the system which is out of compliance. Permission by the department for limiting distribution of the notice must be granted in writing.
  3. A representative copy of the each type of the notice distributed, published, posted and/or made available to the persons served by the system and/or to the media must also be sent to the Department within ten days of completion of each public notification.
- (2) Tier 1 Public Notice—Form, manner, and frequency of notice.
- (a) Violation of the MCL for total coliforms when fecal coliform or E. coli are present in the water distribution system as specified in Rule 0400-45-01-.06, or when the water system fails to test for fecal coliforms or E. coli when any repeat sample tests positive for coliform as specified in Rule 0400-45-01-.07; Violation of the MCL for E. coli (as specified in Rule 0400-45-01-.06(4)(f));

Table 0400-45-01-.19(2)(a)

Violation Categories and Other Situations  
Requiring a Tier 1 Public Notice

- 
1. Violation of the MCL for total coliforms when fecal coliform or E. coli are present in the water distribution system as specified in Rule 0400-45-01-.06, or when the water system fails to test for fecal coliforms or E. coli when any repeat sample tests positive for coliform as specified in Rule 0400-45-01-.07;
  2. Violation of the MCL for nitrate, nitrite, or total nitrate and nitrite, as defined in Rule 0400-45-01-.06, or when the water system fails to take a confirmation sample within 24 hours of the system's receipt of the first sample showing an exceedance of the nitrate or nitrite MCL, as specified in Rule 0400-45-01-.09;
  3. Exceedance of the alternate MCL for nitrate by non-community water systems (NCWS), where the non-community system has been granted an alternate standard by the department;
  4. Violation of the MRDL for chlorine dioxide, as defined in Rule 0400-45-01-.36, when one or more samples taken in the distribution system the day following an exceedance of the MRDL at the entrance of the distribution system exceed the MRDL, or when the water system does not take the required samples in the distribution system, as specified in Rule 0400-45-01-.36;
  5. Violation of the turbidity MCL under Rule 0400-45-01-.06, where the department determines after consultation that a Tier 1 notice is required or where consultation does not take place within 24 hours after the system learns of the violation;

(Rule 0400-45-01-.19, continued)

6. Violation of the Surface Water Treatment Rule (SWTR) Rule 0400-45-01-.31, Interim Enhanced Surface Water Treatment Rule (IESWTR) or Long Term 1 Enhanced Surface Water Treatment Rule (LT1ESWTR) treatment technique requirement resulting from a single exceedance of the maximum allowable turbidity limit (as identified in Appendix A) where the department determines after consultation that a tier 1 notice is required or where consultation does not take place within 24 hours after the system learns of the violation;
7. Occurrence of a waterborne disease outbreak, as defined in Rule 0400-45-01-.04, or other waterborne emergency (such as a failure or significant interruption in key water treatment processes, a natural disaster that disrupts the water supply or distribution system, or a chemical spill or unexpected loading of possible pathogens into the source water that significantly increases the potential for drinking water contamination);
8. Other violations or situations with significant potential to have serious adverse effects on human health as a result of short-term exposure, as determined by the Department either in its regulations or on a case-by-case basis.
9. Detection of *E. coli* or enterococci in source water samples as specified in paragraph (3) of Rule 0400-45-01-.40.

---

(b) When is the Tier 1 public notice to be provided? What additional steps are required? Public water systems must:

1. Provide a public notice as soon as practical but no later than 24 hours after the system learns of the violation;
2. Initiate consultation with the Department as soon as practical, but no later than 24 hours after the public water system learns of the violation or situation, to determine additional public notice requirements; and
3. Comply with any additional public notification requirements (including any repeat notices or direction on the duration of the posted notices) that are established as a result of the consultation with the Department. Such requirements may include the timing, form, manner, frequency, and content of repeat notices (if any) and other actions designed to reach all persons served.

(c) What is the form and manner of the public notice? Public water systems must provide the notice within 24 hours in a form and manner reasonably calculated to reach all persons served. The form and manner used by the public water system are to fit the specific situation, but must be designed to reach residential, transient, and non-transient users of the water system. In order to reach all persons served, water systems are to use, at a minimum, one or more of the following forms of delivery:

1. Appropriate broadcast media (such as radio and television);
2. Posting of the notice in conspicuous locations throughout the area served by the water system;
3. Hand delivery of the notice to persons served by the water system; or
4. Another delivery method approved in writing by the department.

(3) Tier 2 Public Notice—Form, manner, and frequency of notice.



(Rule 0400-45-01-.19, continued)

- (a) Which violations or situations require a Tier 2 public notice? Table 0400-45-01-.19(3)(a) lists the violation categories and other situations requiring a Tier 2 public notice. Appendix A to this rule identifies the tier assignment for each specific violation or situation.

Table 0400-45-01-.19(3)(a)

Violation Categories and Other Situations  
Requiring a Tier 2 Public Notice

- 
1. All violations of the MCL, MRDL, and treatment technique requirements, except where a Tier 1 notice is required under subparagraph (2)(a) of this rule or where the department determines that a Tier 1 notice is required;
  2. Violations of the monitoring and testing procedure requirements, where the department determines that a Tier 2 rather than a Tier 3 public notice is required, taking into account potential health impacts and persistence of the violation; and
  3. Failure to comply with the terms and conditions of any variance or exemption in place.
  4. Failure to take corrective action or failure to maintain at least 4-log treatment of viruses (using inactivation, removal, or a Department-approved combination of 4-log virus inactivation and removal) before or at the first customer under subparagraph (4)(a) of Rule 0400-45-01-.40.
- 

(b) When is the Tier 2 public notice to be provided?

1. Public water systems must provide the public notice as soon as practical, but no later than 30 days after the system learns of the violation. If the public notice is posted, the notice must remain in place for as long as the violation or situation persists, but in no case for less than seven days, even if the violation or situation is resolved. The department may, in appropriate circumstances, allow additional time for the initial notice of up to three months from the date the system learns of the violation. The department will not grant an extension to the 30-day deadline for any unresolved violation or to allow across-the-board extensions by rule or policy for other violations or situations requiring a Tier 2 public notice. Extensions granted by the department must be in writing.
2. The public water system must repeat the notice every three months as long as the violation or situation persists, unless the primacy agency determines that appropriate circumstances warrant a different repeat notice frequency. In no circumstance may the repeat notice be given less frequently than once per year. The Department will not through its rules or policies permit across-the-board reductions in the repeat notice frequency for other ongoing violations requiring a Tier 2 repeat notice. The Department will not allow through its rules or policies less frequent repeat notice for an MCL or treatment technique violation under Rule 0400-45-01-.07 (Monitoring) or Rule 0400-45-01-.41 (Revised Total Coliform Rule) or a treatment technique violation under Rule 0400-45-01-.31 (Filtration and Disinfection). Department determinations allowing repeat notices to be given less frequently than once every three months must be in writing.
3. For the turbidity violations specified in this paragraph, public water systems must consult with the Department as soon as practical but no later than 24 hours after the public water system learns of the violation, to determine whether a Tier 1 public notice under subparagraph (2)(a) of this rule is required to protect public

(Rule 0400-45-01-.19, continued)

Appendix A to this rule identifies the tier assignment for each specific violation or situation.

Table 0400-45-01-.19(4)

Violation Categories and Other Situations Requiring a Tier 3 Public Notice

- 
1. Monitoring violations for the primary drinking water contaminants, except where a Tier 1 notice is required under subparagraph (2)(a) of this rule or where the department determines that a Tier 2 notice is required;
  2. Failure to comply with an approved departmental or EPA testing procedure, except where a Tier 1 notice is required under subparagraph (2)(a) of this rule or where the department determines that a Tier 2 notice is required;
  3. Operation under a variance granted under Section 1415 or an exemption granted under Section 1416 of the Safe Drinking Water Act;
  4. Availability of unregulated contaminant monitoring results, as required under paragraph (7) of this rule;
  5. Exceedance of the fluoride secondary maximum contaminant level (SMCL), as required under paragraph (8) of this rule; and
  6. Reporting and Recordkeeping violations under Rule 0400-45-01-.41.
- 

(b) When is the Tier 3 public notice to be provided?

1. Public water systems must provide the public notice not later than one year after the public water system learns of the violation or situation or begins operating under a variance or exemption. Following the initial notice, the public water system must repeat the notice annually for as long as the violation, variance, exemption, or other situation persists. If the public notice is posted, the notice must remain in place for as long as the violation, variance, exemption, or other situation persists, but in no case less than seven days (even if the violation or situation is resolved).
2. Instead of individual Tier 3 public notices, a public water system may use an annual report detailing all violations and situations that occurred during the previous twelve months, as long as the timing requirements of part 1. of this subparagraph are met.

(c) What is the form and manner of the Tier 3 public notice? Public water systems must provide the initial notice and any repeat notices in a form and manner that is reasonably calculated to reach persons served in the required time period. The form and manner of the public notice may vary based on the specific situation and type of water system, but it must at a minimum meet the following requirements:

1. Unless directed otherwise by the Department in writing, community water systems must provide notice by:

(Rule 0400-45-01-.31, continued)

of providing continuous monitoring on an ongoing basis at the frequencies prescribed below:

System Size by Population	Samples/day <sup>1</sup>
<500	1
501 to 1,000	2
1,001 to 2,500	3
2,501 to 3,300	4

<sup>1</sup>The day's samples cannot be taken at the same time. The sampling intervals are subject to Department review and approval.

If at any time the free residual disinfectant concentration falls below 0.2 mg/l in a system using grab sampling in lieu of continuous monitoring, the system must take a grab sample every four hours until the free residual disinfectant concentration is equal to or greater than 0.2 mg/l.

3. Until March 31, 2016, the residual disinfectant concentration must be measured at least at the same points in the distribution system and at the same time as total coliforms are sampled, as specified in paragraph (1) of Rule 0400-45-01-.07. Beginning April 1, 2016, the residual disinfectant concentration must be measured at least at the same points in the distribution system and at the same time as total coliforms are sampled, as specified in paragraphs (4) through (8) of Rule 0400-45-01-.41. The Department may allow a public water system which uses both a surface water source or a groundwater source under direct influence of surface water, and a groundwater source to take disinfectant residual samples at points other than the total coliform sampling points if the Department determines that such points are more representative of treated (disinfected) water quality within the distribution system. Heterotrophic bacteria, measured as heterotrophic plate count (HPC) as specified in part (10)(a)4. of Rule 0400-45-01-.14, may be measured in lieu of residual disinfectant concentration.
4. In addition to monitoring required by parts 1., 2. and 3. of this subparagraph, a subpart H system serving 10,000 or more persons using conventional filtration treatment or direct filtration must conduct continuous monitoring of turbidity for each individual filter using an approved method in subparagraph (10)(b) of Rule 0400-45-01-.14 and must calibrate turbidimeters using the procedure specified in paragraphs (40) and (41) of Rule 0400-45-01-.17. Systems must record the results of individual filter monitoring every 15 minutes. In addition to monitoring required by parts 1, 2 and 3 of this subparagraph by January 14, 2005, a subpart H system serving fewer than 10,000 persons using conventional filtration treatment or direct filtration must conduct continuous monitoring of turbidity for each individual filter using an approved method in subparagraph (10)(b) of Rule 0400-45-01-.14 and must calibrate turbidimeters using the procedure specified in paragraphs (40) and (41) of Rule 0400-45-01-.17. Systems must record the results of individual filter monitoring every 15 minutes.
5. If there is a failure in the continuous turbidity monitoring equipment, the system must conduct grab sampling every four hours in lieu of continuous monitoring until the turbidimeter is repaired and back on-line. A system has a maximum of five working days after failure to repair the equipment or it is in violation.

(6) Reporting and recordkeeping requirements.

# Continuing Education Requirements

The following hours of Continuing Education are required to maintain certification.

Certification Title	Number of Continuing Education Hours Needed
Biological/Natural Systems	6 hours every 3 years
Collection 1	6 hours every 3 years
Collection 2	6 hours every 3 years
Distribution 1	6 hours every 3 years
Distribution 2	6 hours every 3 years
Small Water System	6 hours every 3 years
Water Treatment 1	6 hours every 3 years
Water Treatment 2	6 hours every 3 years
Water Treatment 3	12 hours every 3 years
Water Treatment 4	12 hours every 3 years
Wastewater Treatment 1	6 hours every 3 years
Wastewater Treatment 2	6 hours every 3 years
Wastewater Treatment 3	12 hours every 3 years
Wastewater Treatment 4	12 hours every 3 years

**Fleming Training Center**  
 2022 Blanton Drive  
 Murfreesboro, TN 37129  
 Phone: 615-898-8090  
 Fax: 615- 898-8064

Beginning October 1, 2002

## **Section 14**

### **Sacramento & AWWA Review Questions**



## Sacramento & AWWA Review Questions

## References



### What is stratification in lakes and reservoirs?

- Breezes starting the circulation of surface water
- Formation of separate layers of temperature, plant life, or animal life
- Lake turnover due to temperature changes
- Uniform water temperature profile from surface to bottom

\*Sacramento, Chapter 1 – Introduction to Water Distribution

### What causes the elevation and slope of water tables and artesian pressure levels to change?

- Collection of water into a reservoir
- Pollution from agricultural activities
- Seasonal variations in the supply of water
- Selection of intake structures

\*Sacramento, Chapter 1

### How extensive should the treatment be for reclaimed water?

- Depends on climate conditions at point of use
- Depends on potential exposure to the public
- Depends on the funds available for treatment
- Depends on the NPDES permit

\*Sacramento, Chapter 1

### What is one difference between primary and secondary drinking water regulations?

- Primary regulations are mandatory limits while secondary regulations are guidelines
- Primary regulations limit chemical contaminants while secondary regulations limit biological contaminants
- Primary regulations cannot be changed while secondary regulations are constantly changing
- Primary regulations apply to treatment plants while secondary regulations apply to distribution systems

\*Sacramento, Chapter 1

## What is palatable water?

- A. Water at a desirable temperature that is free from objectionable tastes, odors, colors, and turbidity
- B. Water that does not contain objectionable pollution, contamination, minerals, or infective agents and is considered satisfactory for drinking
- C. Water in its natural state, before any treatment
- D. Water having a low concentration of calcium and magnesium ions

\*Sacramento, Chapter 1

## What are two causes of backflow through a cross-connection?

- A. Low circulation and stagnant water
- B. Chemical and electrochemical reactions
- C. Back pressure and backsiphonage
- D. Pockets of sediments and slimes

\*Sacramento, Chapter 1

## Which form of chlorine is most effective against biofilms?

- A. Free chlorine
- B. Chlorine dioxide
- C. Chlorine residual
- D. Chloramines

\*Sacramento, Chapter 1

## What influences the potential for corrosion in metal or asbestos pipe that is lined with asphalt or coal tar?

- A. Increased chlorine demand
- B. Amount of interface in the pipe
- C. Proximity to hazardous facilities
- D. Integrity of the coating

\*Sacramento, Chapter 1

## How often should reservoirs be inspected?

- A. At least once a month
- B. At least twice a month
- C. At least daily
- D. At least twice a week

\*Sacramento, Chapter 1

## Why are uncovered reservoirs often prohibited?

- A. Subject to contamination from many sources
- B. Must be located far from other facilities
- C. Rarely produce sufficient system pressures
- D. Difficult to construct and repair

\*Sacramento, Chapter 1

What is an important aspect of a tank inspection and maintenance program?

- A. Ensuring adequate turnover of water in the tank
- B. Main replacement and repair procedures
- C. Unidirectional flushing
- D. Investigating and responding to complaints

\*Sacramento, Chapter 1

Why should an O&M program include exercising the vales?

- A. To control biofilm
- B. To prevent backflow
- C. To ensure proper setting and operation
- D. To eliminate dead ends

\*Sacramento, Chapter 1

What is the responsibility of water treatment plant operators?

- A. Avoid boil-water orders
- B. Minimize cost of producing drinking water
- C. Produce safe and pleasant drinking water
- D. Successfully pass operator certification examinations

\*Sacramento, Chapter 1

What do most states require for someone to work as a water treatment plant operator?

- A. First-aid training
- B. College diploma
- C. Driver's license
- D. Operator certificate

\*Sacramento, Chapter 1

What contributes to most treatment plant accidents?

- A. Application and knowledge of safe procedures
- B. Carelessness and neglect
- C. Availability and convenience of safety equipment
- D. Plant design and construction

\*Sacramento, Chapter 1

Which type of storage facility is used for filtered water from water treatment plants?

- A. Clear well
- B. Elevated tank
- C. Pressure tank
- D. Standpipe

\*Sacramento, Chapter 2 – Water Storage Facilities



What is the primary purpose of elevated tanks?

- A. To attract commercial and industrial development
- B. To enhance the scenery in a community
- C. To maintain adequate and fairly uniform pressure to a service area
- D. To prevent graffiti and vandalism to storage facilities

\*Sacramento, Chapter 2

Why should reservoirs be covered?

- A. To reduce the possibility of contamination
- B. To reduce the amount of evaporation
- C. To reduce the amount of paint required to cover reservoir surfaces
- D. To reduce the time required for inspections

\*Sacramento, Chapter 2

How do surge arrestors protect piping systems from hydraulic transients?

- A. By shutting down pumps in the water system
- B. By controlling unusual velocity changes
- C. By recording changes in flow rates
- D. By sounding an alarm

\*Sacramento, Chapter 2

What is an advantage of using surge control valves in a water distribution system?

- A. Easy to purchase
- B. Easy to justify cost
- C. Easy to fit into plant
- D. Easy to buy replacement parts

\*Sacramento, Chapter 2

What is the main function of a distribution storage facility?

- A. To allow operators time for training during periods of low demand
- B. To keep facilities operating during minimum flow periods
- C. To provide for park facilities in conjunction with the storage facilities
- D. To take care of daily demands and especially peak demands

\*Sacramento, Chapter 2

Which change in water level occurs during peak demand in distribution storage facilities?

- A. Water levels drop
- B. Water levels rise
- C. Water levels remain steady
- D. Water levels vary

\*Sacramento, Chapter 2

What do turbidity units (TU) measure in water systems?

- A. Acidity of water
- B. Pollution of water
- C. Cloudiness of water
- D. Temperature of water

\*Sacramento, Chapter 2

What are the three types of maintenance?

- A. Preventative, predictive, corrective
- B. Collateral, standard, reactive
- C. Regulated, structured, prescribed
- D. Designated, scripted, legislated

\*Sacramento, Chapter 2

Which substance in the water influences the rate of corrosion in a storage facility?

- A. Carbon monoxide
- B. Dissolved oxygen
- C. Sulfate-increasing bacteria
- D. Dissolved solvents

\*Sacramento, Chapter 2

Where should a water system store nameplate data?

- A. With personal records
- B. With financial records
- C. With equipment records
- D. With timesheet records

\*Sacramento, Chapter 2

In which areas of a storage facility should safety treads be installed?

- A. Regulator stations
- B. Storage facility stairs
- C. Storage tank doors
- D. Centrifugal pumps

\*Sacramento, Chapter 2

What is friction loss?

- A. A reverse flow condition created by a difference in water pressures that causes water to flow back into the distribution pipes of a potable water supply from any source or sources other than an intended source
- B. The surface or profile of water flowing in an open channel or a pipe flowing partially full
- C. The head, pressure, or energy lost by water flowing in a pipe or channel as a result of turbulence caused by the velocity of the flowing water and the roughness of the pipe, channel walls, or restrictions caused by fittings
- D. The vertical distance equal to the pressure at a specific point

\*Sacramento, Chapter 3 – Distribution System Facilities

Why might a distribution system need to be oversized to meet fire demands?

- A. To ensure that the system does not experience excessive pressure during a fire
- B. A fire will draw water from the source very quickly
- C. A fire can put very high demands on a system for short periods of time
- D. To reduce the cost of pumping during a fire

\*Sacramento, Chapter 3

What determines whether transmission mains are short or long and whether the water is transported by gravity or pumping?

- A. Location of the source
- B. The materials used for transmission main construction
- C. Treatment requirements to ensure safe water
- D. Budget for the distribution system

\*Sacramento, Chapter 3

Why should storage tanks be located in the center of use?

- A. So that tanks do not interfere with the views from houses and businesses
- B. To provide larger capacities with fewer units
- C. To reduce pumping costs
- D. To maintain adequate pressures even during periods of high demand

\*Sacramento, Chapter 3

Why are storage pumps often installed in parallel?

- A. To dewater the reservoir to allow for inspection and cleaning
- B. To permit the economical location of storage at the desirable hydraulic elevation of the system
- C. To enable the number of pumps in operation to be varied depending on the flow through the pumping station
- D. To serve relatively few customers located on very high or remote points

\*Sacramento, Chapter 3

What is the first choice of methods to protect pipe from corrosion?

- A. Proper use of noncorrosive metals and mechanical coatings
- B. Chemical control methods
- C. Cathodic protection
- D. Vacuum, pressure-relief, and pressure-reducing valves

\*Sacramento, Chapter 3

When installing water mains parallel to sanitary sewers, what is the recommended minimum horizontal separation between the two pipes?

- A. 6 feet
- B. 10 feet
- C. 8 feet
- D. 4 feet

\*Sacramento, Chapter 3

What is shoring?

- A. An area near a body of water with a high groundwater table
- B. A complete framework of wood or metal that is designed to support the walls of a trench
- C. An area where surface water is readily visible and scenic
- D. A wooden or metal wall placed on a trench

\*Sacramento, Chapter 3

When installing braces or screw jacks, which one should be installed first?

- A. Right brace or jack
- B. Bottom brace or jack
- C. Top brace or jack
- D. Left brace or jack

\*Sacramento, Chapter 3

Which type of valve has a movable disc as large as the full diameter of the pipe?

- A. Gate valve
- B. Ball valve
- C. Plug valve
- D. Butterfly valve

\*Sacramento, Chapter 3

Where are pressure relief valves most commonly installed?

- A. On pipes 4 inches in diameter and smaller
- B. On supply lines to elevated tanks or standpipes
- C. At the high point of a line
- D. On the side outlet of a tee at a specific point in the system

\*Sacramento, Chapter 3

How can a distribution system avoid putting large areas out of service for repairs or replacement?

- A. Install valves in enough locations that relatively small parts of the system can be shut off
- B. Only make repairs that can be completed while the line stays in service
- C. Install backflow prevention devices in enough locations that relatively small parts of the system can be shut off
- D. Install valves that can be operated by actuators

\*Sacramento, Chapter 3

Which fittings are used to change the direction of flow in a distribution system?

- A. Caps, plugs, and blind flanges
- B. Expansion joints, reducing flanges, and Y-laterals
- C. Clamps, sleeves, and adapters
- D. Elbows, tees, and bends

\*Sacramento, Chapter 3

What is the main advantage of compound meters?

- A. Their low head loss is ideal for a meter than must pass high rates of flow
- B. They are less expensive than Venturi meters
- C. They can measure wide variations of flow rate within their rated capacity
- D. They accurately measure flows from a fraction of a gallon to the normal capacity of the pipeline

\*Sacramento, Chapter 3

Where does the service line to the customer's system start?

- A. At the main with a corporation stop
- B. At the property line with a shutoff valve
- C. At the lateral with a curb stop
- D. At the curb stop with a meter

\*Sacramento, Chapter 3

What is one way to correctly size a meter on a service connection?

- A. The meter should be the same size as the service line
- B. The meter should be one size larger than the service line
- C. The meter should be one size smaller than the service line
- D. The meter should be proportional to the main

\*Sacramento, Chapter 3

Which means of backflow prevention provides the most protection?

- A. Reduced-pressure principle device
- B. Back pressure device
- C. Air gap
- D. Double check valve

\*Sacramento, Chapter 3

What water quality safeguards protect against vandalism?

- A. Locks on doors and gates
- B. Chlorine residual and large dilution factor
- C. Reservoir covers and vent screens
- D. Turbidity and alkalinity

\*Sacramento, Chapter 4 – Operation and Maintenance

What may a lack of chlorine residual indicate?

- A. Heavy contamination
- B. Need for a cross-connection control program
- C. Adequate control of coliform aftergrowth
- D. Poor sampling techniques

\*Sacramento, Chapter 4

## What is backsiphonage?

- A. A form of backflow caused by negative or below atmospheric pressure within the water supply piping
- B. A form of flow created by higher than normal pressures in the water supply piping
- C. A form of reverse flow caused by excessive contamination of the water supply piping
- D. A form of siphoning water out of containers or tanks into the water mains

\*Sacramento, Chapter 4

## What is the water user's responsibility in a cross-connection program?

- A. Promulgating and enforcing laws, rules, regulations, and policies needed to control cross-connections
- B. Keeping contaminants out of the potable water system on the user's premises
- C. Managing a program that ensures maintenance of an adequate cross-connection program
- D. Listing and inspecting all existing facilities where cross-connections are of concern

\*Sacramento, Chapter 4

## Why must a continuous positive pressure be maintained at all times in the water distribution system?

- A. To have water available for fire protection
- B. To minimize complaints from lack of water
- C. To prevent contamination from backflow
- D. To reduce unaccounted-for water losses due to leaks

\*Sacramento, Chapter 4

## What is the main function of a distribution storage facility?

- A. To allow operators time for training during low demand periods
- B. To keep facilities operating during minimum flow periods
- C. To provide for park facilities in conjunction with the storage facility
- D. To take care of daily demands and especially peak demands

\*Sacramento, Chapter 4

## Why should pump alignment be checked periodically?

- A. To guard against premature bearing and coupling wear
- B. To prevent excessive or abnormal noise, vibration, heat, and odor
- C. To prevent the pump from running dry
- D. To guard against undue packing wear and even a scored shaft or sleeve

\*Sacramento, Chapter 4

## What is the purpose of pipe flushing?

- A. To clean out distribution pipelines by removing any impurities or sediment that may be present in the pipe
- B. To maintain minimum dry weather flows in nearby creeks
- C. To remove stale or stagnant water from the system
- D. To swab out the inside of pipes prior to disinfection

\*Sacramento, Chapter 4

Why are test pipe specimens (coupons) placed in water distribution systems?

- A. To measure the cavitation of water
- B. To measure the corrosiveness of water
- C. To measure the flow of water
- D. To measure the velocity of water

\*Sacramento, Chapter 4

When must distribution system storage facilities be disinfected?

- A. When the chlorine residual becomes too high
- B. When the system pressure is too low
- C. When they are taken out of service for any reason
- D. Whenever bacteriological samples are collected

\*Sacramento, Chapter 4

What makes for a good filing system for water distribution system records?

- A. Can be easily used and understood, readily accessible, and protected from damage in a safe environment
- B. Only accepts paper copies of important information
- C. Requires transferring information from one format to another
- D. Retains all records indefinitely

\*Sacramento, Chapter 4

What is a SCADA system?

- A. Computer control system
- B. Engineering drawings that show the depth of pipe, pipe location, and the correct distance from a reference starting point
- C. Software that links geographic information with descriptive information
- D. Computer recordkeeping system

\*Sacramento, Chapter 4

What will determine what equipment and stores are needed and how much should usually be kept on hand?

- A. Motorized equipment categories
- B. Available storage facilities
- C. System requirements
- D. Number of employees

\*Sacramento, Chapter 4

What are the economic benefits of natural landscaping?

- A. Reduces costs of landscaping installation and maintenance and stormwater management facilities
- B. Reduced soil erosion, air pollution, and greenhouse effects
- C. Habitat restoration and protection and site beautification
- D. Increased public awareness and understanding of the importance of protecting and conserving water and other natural resources

\*Sacramento, Chapter 4

What is not a type of physical disinfection?

- A. Chlorine
- B. Heat
- C. Ultrasonic waves
- D. Ultraviolet rays

\*Sacramento, Chapter 5 - Disinfection

What is not a chemical disinfectant?

- A. Bromine
- B. Carmine
- C. Ozone
- D. Sodium hydroxide

\*Sacramento, Chapter 5

What is a limitation of prechlorination?

- A. May control algal and slime growths
- B. May control mudball formation
- C. May increase chlorine contact time
- D. May increase the formations of THMs in raw water

\*Sacramento, Chapter 5

Why do you not use wrenches longer than 6 inches (15cm), pipe wrenches, or wrenches with an extension to open chlorine container valves?

- A. These wrenches are only available in metric sizes
- B. These wrenches are too costly
- C. These wrenches do not fit on chlorine container valves
- D. You could exert too much force and break the valve

\*Sacramento, Chapter 5

What should be done to the water supply pump when the hypochlorinator is shut down?

- A. Operate the water supply pump as usual
- B. Start the pump slowly to ease into full operation
- C. Turn water supply pump off
- D. Turn water supply pump on at full operation

\*Sacramento, Chapter 5

If consumers complain about chlorine tastes in their drinking water, what is the most likely cause of this problem?

- A. The chlorine dose is inadequate
- B. The chlorine dose is the wrong mix of chemicals
- C. The chlorine dose is too high
- D. The chlorine dose was added too late in the treatment process

\*Sacramento, Chapter 5



What can cause a false positive chlorine residual reading when performing the DPD method?

- A. Buffer
- B. Caustic soda
- C. Precipitate
- D. Short-circuiting

\*Sacramento, Chapter 5

Which item is not included in a chlorine safety program?

- A. Atmospheric monitoring devices
- B. Leak-detection equipment
- C. Oral rules and safety procedures
- D. Self-contained breathing apparatus

\*Sacramento, Chapter 5

What is the objective of a safety program?

- A. To educate operators
- B. To minimize costs
- C. To prevent accidents
- D. To protect the public

\*Sacramento, Chapter 6 - Safety

What is one description of safety?

- A. Disregarding rules or instructions
- B. Neglecting training
- C. Taking unnecessary risks
- D. Using one's knowledge or skill to avoid accidents

\*Sacramento, Chapter 6

Who is mainly responsible for safety?

- A. Everyone, from top management to all employees
- B. Safety inspectors
- C. Safety magazine editors and reporters
- D. Safety regulatory agencies

\*Sacramento, Chapter 6

Tailgate safety sessions are usually held near the work site to discuss which topics?

- A. Current labor contract negotiations and health benefit enrollments
- B. Distribution of regular shifts and overtime
- C. Requests for vacation and other personal leave time
- D. Safety hazards and safe approaches or techniques to deal with the problems of the day

\*Sacramento, Chapter 6

What is the purpose of employee Right-To-Know laws?

- A. To require employers to inform operators of job opportunities with other water utility agencies
- B. To require employers to inform operators of educational opportunities within the utility
- C. To require employers to inform operators of the possible health effects resulting from contact with hazardous substances
- D. To require employers to inform operators of their legal right to knowledge

\*Sacramento, Chapter 6

Why should cars not be allowed to touch when recharging the battery?

- A. A dangerous arcing situation could occur
- B. A driver in one or both of the vehicles could be electrocuted
- C. The current will flow to the other car, rather than the battery
- D. The good battery will lose its entire charge

\*Sacramento, Chapter 6

What is dangerous air contamination?

- A. An atmosphere presenting a threat of causing death, injury, acute illness, or disablement due to the presence of flammable/explosive, toxic, or otherwise injurious or incapacitating substances
- B. An atmosphere that has limited or restricted means for entry or exit
- C. An atmosphere that is large enough and configured such that an employee can easily enter the atmosphere and perform assigned work
- D. At atmosphere that is not designed for continuous employee occupancy

\*Sacramento, Chapter 6

What is the first step of atmospheric testing that should be performed before entering a confined space?

- A. Barely open the confined space to test the atmosphere
- B. Calibrate the gas detection device
- C. Record the results of atmospheric tests in the gas log
- D. Test for combustible and toxic gases and oxygen deficiency/enrichment

\*Sacramento, Chapter 6

Which items are among the protective safety equipment that may be required or supplied by the water utility?

- A. Cold weather hats or ear coverings
- B. Earplugs and safety (hard) hats
- C. Prescription safety glasses
- D. Safety mouth guards

\*Sacramento, Chapter 6

Which type of material should be used to clean up liquid spills on floors?

- A. Any material that is within reach
- B. Chemically treated burlap
- C. Nonflammable absorbent material
- D. Well water at room temperature

\*Sacramento, Chapter 6

Why does the selection of a well site require serious consideration?

- A. To ensure that the well is located a suitable distance from any potential pollution source that may adversely affect groundwater
- B. To ensure that the well is located in a flood zone where the groundwater can be recharged during floods
- C. To ensure that the well is located in a low spot where there will be plenty of water
- D. To ensure that the well is located where the land will not be rezoned for commercial use in the near future

\*Sacramento, Chapter 6

All surface openings installed on top of a well must be protected against what?

- A. Changes in the sizes of the openings
- B. Entrance by unauthorized or unqualified personnel
- C. Entrance of surface water or foreign matter
- D. Unauthorized or improper maintenance

\*Sacramento, Chapter 6

Why may acid treatment be necessary for a well?

- A. To control corrosion of the well casing
- B. To disinfect and inactivate pathogens in the well
- C. To dissolve iron and manganese ions in the well
- D. To loosen incrustations from a well casing and well

\*Sacramento, Chapter 6

What safety precaution should be practiced when mixing an acid with water?

- A. Add the acid quickly to the water
- B. Add the acid slowly to the water
- C. Add the water quickly to the acid
- D. Add the water slowly to the acid

\*Sacramento, Chapter 6

Why should wells that are no longer useful be abandoned and plugged?

- A. To ensure that the groundwater is protected and preserved for further use
- B. To improve the aesthetics of the site
- C. To prevent overdraft of groundwater
- D. To reduce subsidence

\*Sacramento, Chapter 6

What is the purpose of closed guards on pumps?

- A. To allow moving parts to move or rotate freely without being damaged
- B. To hold moving parts in place while they are rotating
- C. To prevent access to dangerous parts at all times by enclosing the hazardous operation completely
- D. To protect moving parts from being struck by stationary objects

\*Sacramento, Chapter 6

Which equipment must be locked out and tagged whenever it is being worked on?

- A. All equipment being transferred from one location to another
- B. All equipment hanging from slings in midair
- C. All equipment placed on workbenches for maintenance
- D. All equipment that could unexpectedly start up or release stored energy

\*Sacramento, Chapter 6

The control of traffic is necessary given the amount of time distribution system operators work in traffic while performing which types of tasks?

- A. Completing forms
- B. Disinfecting wells
- C. Laboratory testing
- D. Repair and rehabilitation

\*Sacramento, Chapter 6

What is a temporary traffic control (TTC) plan?

- A. A work zone in an area of a highway with construction, maintenance, or utility work activities
- B. Any location where the sight distance to the work area is sufficient to meet stopping sight distance
- C. The distance required by a driver to properly react to hazardous, unusual, or unexpected situations
- D. Traffic controls to be used for facilitating all traffic through a temporary traffic control zone

\*Sacramento, Chapter 6

Under what conditions must emergency response agencies, such as fire and police departments, be notified before traffic is diverted or disrupted?

- A. When there is a likelihood for increased criminal activity
- B. When there is the possibility of a terrorist threat
- C. When there is the potential for increased fire danger
- D. When traffic diversion or disruption may obstruct access

\*Sacramento, Chapter 6

When modifications must be made to the standard traffic control layouts, what are some factors that must be considered?

- A. Age and skill level of the drivers
- B. Available parking and access to public transit
- C. Landscape features and irrigation supply
- D. Traffic volume and speed, sight distance, and type of work

\*Sacramento, Chapter 6

In relation to excavating trenches, what is spoil?

- A. Material removed from a trench
- B. Material stored in a safe location
- C. Material that was exposed to the elements and is rotting
- D. Material that was previously buried at the site

\*Sacramento, Chapter 6

What defines the work space within an activity area of a traffic control zone?

- A. An area that contains the work activity and is closed to traffic and set aside for workers, equipment, and construction materials
- B. An area that provides a short distance for traffic to clear the work area and to return to the normal traffic lanes
- C. An area that provides recovery space for an out-of-control vehicle
- D. An area where traffic is channelized from the normal highway lanes to the path required to move traffic around the work area

\*Sacramento, Chapter 6

What is the termination area of a traffic control zone?

- A. An area where road users are informed about the upcoming work zone
- B. An area that is used to return road users to their normal driving path
- C. An area that provides recovery space for an out-of-control vehicle
- D. An area where traffic is channelized from the normal highway lanes to the path required to move traffic around the work area

\*Sacramento, Chapter 6

What is the most desirable way to provide information to pedestrians with visual disabilities that is equivalent to visual signage for notification of sidewalk closures?

- A. A flagger directing pedestrians around the closure
- B. A speech message provided by an audible information device
- C. An immovable object that blocks the sidewalk closure
- D. Tape, rope, or plastic chain strung between devices

\*Sacramento, Chapter 6

When working in streets, which public safety precaution must be taken during welding activities?

- A. Flammable materials must be available to absorb welding sparks
- B. Overwelding must be avoided because it could hinder future repair
- C. Suitable screens must be placed to protect the public from arc welding flash or sparks from cutting operations
- D. The equipment must be prevented from encroaching on excavation work

\*Sacramento, Chapter 6

Which condition might require flaggers for temporary traffic control?

- A. All channelizing devices are already in use
- B. Extra staff are available to serve as flaggers
- C. One lane must be used for two directions of traffic
- D. There is little space for advanced warning of the work area

\*Sacramento, Chapter 6

What is one of the best ways to increase the safety of both drivers and operators at construction sites?

- A. Minimize the numbers of both drivers and operators at construction sites
- B. Only allow construction work to occur at night when traffic volume is low
- C. Require all drivers to enroll in safe driving classes
- D. Use temporary traffic control devices in a consistent, predictable manner

\*Sacramento, Chapter 6

When should an arrow board be used in the arrow or chevron mode?

- A. Advising approaching traffic of a lane closure along major multilane roadways
- B. Channeling vehicular traffic away from the work space or pavement dropoffs
- C. Closure, restriction, or delineation of all or a portion of the right-of-way
- D. Dividing opposing vehicular traffic lanes

\*Sacramento, Chapter 6

Which warning lights can be used to inform road users that they are approaching a potentially hazardous area during both daytime and nighttime hours?

- A. Type A low-intensity flashing lights
- B. Type B high-intensity flashing lights
- C. Type C steady-burn warning lights
- D. Type D 360-degree steady-burn warning lights

\*Sacramento, Chapter 6

Who must conduct daily inspections of excavations?

- A. Competent person
- B. Designated operator
- C. Independent investigator
- D. Supervising operator

\*Sacramento, Chapter 6

What causes slippery surfaces around water storage facilities?

- A. Heavy foot traffic wearing out the floor texture
- B. Treated strips of tape-like material affixed to areas where foot traffic is heavy
- C. Water or chemical spills on the floor
- D. Waxed or polished floors

\*Sacramento, Chapter 6

How can major hazards related to ladders be eliminated?

- A. Design and build facilities that do not require climbing
- B. Ensure operators are wearing appropriate protective clothing
- C. Installation and proper use of available climbing safety devices
- D. Train operators to climb ladders quickly

\*Sacramento, Chapter 6

What is one easy way to identify a confined space?

- A. You must ask business owner for permission to enter
- B. You must duck, crawl, climb, or squeeze into the space
- C. You must map the location using GPS
- D. You must use a code to unlock the access point

\*Sacramento, Chapter 6

How can confined spaces be properly ventilated to permit workers to enter safely?

- A. Keep doors and windows open
- B. Leave entry points open and vacant
- C. Use specially designed forced-air ventilators
- D. Vigorously move hand-held fans

\*Sacramento, Chapter 6

Which item in a water system does not contribute to operator noise exposure?

- A. Air compressors
- B. Engine generators
- C. Insertion-type earplugs
- D. Pumps

\*Sacramento, Chapter 6

What is the most effective means of controlling noise?

- A. Operator protection
- B. Path control
- C. Receiver control
- D. Source control

\*Sacramento, Chapter 6

How can operators ensure that important items are not overlooked or forgotten during regular safety inspections?

- A. Assign safety report writing to dedicated employees
- B. Direct two different operators to perform the same inspection
- C. Offer financial incentives to safety inspectors
- D. Use safety inspection forms or reports

\*Sacramento, Chapter 6

What is the managerial function controlling?

- A. Determining the goals, policies, procedures, and other elements to achieve the goals and objectives of the agency
- B. Taking the steps necessary to ensure that essential activities are performed so that objectives will be achieved as planned
- C. Recruiting new operators and staff and determining if there are enough qualified operators and staff to fill available positions
- D. Guiding, teaching, motivating, and supervising operators and utility staff members

\*Sacramento, Chapter 7 - Management

What may be the most difficult planning problem for a small community water service?

- A. Recognizing and planning for a decline in population
- B. Selecting and training employees and evaluating their performance
- C. Keeping up with technological changes and new procedures
- D. Controlling the treatment process to ensure the water is being properly treated

\*Sacramento, Chapter 7

What components make up a successful delegation by a supervisor?

- A. Power and resources to do a specific job
- B. Organizational plan and written policies
- C. Short and long-term goals and plans
- D. Proper job assignments, authority, and responsibility

\*Sacramento, Chapter 7

What is responsibility?

- A. The power and resources to do a specific job or to get the job done
- B. Answering to those above you in the chain of command to explain how and why you have used your authority
- C. Power is given to another person in the organization to accomplish a specific job
- D. When a manager gives power or responsibility to an employee, the employee ensures that the manager is informed of results or events

\*Sacramento, Chapter 7

Why should a manager examine the functions and staffing of the utility on a periodic basis?

- A. To ensure that the utility is operating as efficiently as possible
- B. To develop qualifications profiles
- C. To eliminate unqualified applicants from the interview pool
- D. To answer questions from new employees during employee orientation

\*Sacramento, Chapter 7

What is the best way for a manager to prevent harassment in the workplace?

- A. Ignore occasional flirting, innuendo, or jokes that do not meet the legal definition of harassment
- B. Insist that the employee with a complaint meet with the employee the complaint is against
- C. Set an example by behavior and keep communication open between employees
- D. Distribute copies of the utility's harassment policy

\*Sacramento, Chapter 7

What should the utility's annual report summarize?

- A. Spare parts inventory, preventative maintenance task lists, and purchase orders for the last year
- B. Daily flow rates, new connections installed, and repairs completed for the last year
- C. Expenses, treatment services provided, and revenues generated over the last year
- D. Employee records, including pay rates, disciplinary actions, and sick leave taken over the last year

\*Sacramento, Chapter 7

Why should all employees be trained to deal positively with the public?

- A. To evaluate employees' ability to make prepared speeches
- B. To get press coverage for events and press conferences
- C. To prepare operators for arguments with consumers
- D. To contribute to favorable first impressions of the organization

\*Sacramento, Chapter 7



What is the purpose of a repair/replacement fund?

- A. To generate additional revenue to improve the coverage and operating ratios
- B. To generate additional revenue to reduce water rates for economically disadvantaged consumers
- C. To generate additional revenue to pay for system expansion
- D. To generate additional revenue to pay for the repair or replacement of capital equipment as the equipment wears out

\*Sacramento, Chapter 7

To decide among several options to meet a capital improvement need, what do you need to calculate?

- A. Payback time
- B. Present value
- C. Water rates
- D. Operating ratio

\*Sacramento, Chapter 7

If a utility uses corrective maintenance practices, when is maintenance performed?

- A. On a regular schedule
- B. During emergencies
- C. After a calendar period or specified operating time
- D. When equipment or a system fails

\*Sacramento, Chapter 7

What are SCADA systems used to monitor in water applications?

- A. Pumps, valves, and alarms
- B. Levels, pressures, and flows
- C. Unusual sounds, odors, and appearance
- D. Consumer complaints, rates, and budget projections

\*Sacramento, Chapter 7

How can a utility identify critical components in the system that may fail during an emergency situation?

- A. Water quality tests
- B. Vulnerability assessment
- C. Financial audit
- D. System inventory

\*Sacramento, Chapter 7

What is lethal dose 50 used to express?

- A. The concentration of a contaminant that will produce 50 percent fatalities from an average exposure
- B. The maximum concentration of the contaminant allowed in drinking water
- C. The duration of exposure to the contaminant that causes acute injury
- D. The solubility of the contaminant in a given organism

\*Sacramento, Chapter 7

Who is responsible for the implementation and enforcement of the safety program?

- A. Operator
- B. Support staff
- C. Manager
- D. Board of directors

\*Sacramento, Chapter 7

What are the basic elements of a water conservation strategy?

- A. Public information programs
- B. WaterSense program
- C. Commercial/industrial/institutional (CII) accounts
- D. Best management practices (BMPs)

\*Sacramento, Chapter 7

What does conservation pricing induce customers to reduce?

- A. Budget to actual consumption ratios
- B. Climate-appropriate landscape design
- C. Coordination and oversight
- D. Average or peak use or both

\*Sacramento, Chapter 7

Which agency sets legal limits on the concentration levels of harmful contaminants in potable water distributed to customers?

- A. National Primary Drinking Water Regulations Agency
- B. US Environmental Protection Agency
- C. US Public Health Service
- D. Occupational Health and Safety Administration

\*AWWA, Chapter 1 – USEPA Drinking Water Regulations

The number of monthly distribution system bacteriological samples required is?

- A. Based on the water withdrawal permit limit
- B. Based on system size
- C. Based on population served
- D. Different for each state

\*AWWA, Chapter 1

What is the maximum contaminant level for total trihalomethans (TTHM) in the United States?

- A. 0.040 mg/L
- B. 0.060 mg/L
- C. 0.080 mg/L
- D. 0.100 mg/L

\*AWWA, Chapter 1

Under the Surface Water Treatment Rule, disinfection residuals must be collected at the same location in the distribution system as?

- A. Coliform samples
- B. Total trihalomethanes
- C. Disinfection by-products
- D. Alkalinity, conductivity, and pH for corrosion studies

\*AWWA, Chapter 1

Iron can cause “red water” and thus customer complaints when its concentration is above its secondary maximum contaminant level of?

- A. 0.01 mg/L
- B. 0.05 mg/L
- C. 0.10 mg/L
- D. 0.30 mg/L

\*AWWA, Chapter 1

The goal of the Surface Water Drinking Act is for each \_\_\_\_ to accept primary enforcement responsibility (primacy) for the operation of the state’s drinking water program.

- A. State
- B. Water treatment plant
- C. Operator
- D. Municipality

\*AWWA, Chapter 1

What is the objective of the Total Coliform Rule?

- A. To provide *Cryptosporidium* protection in new facilities
- B. To ensure safe levels of lead and copper in drinking water
- C. To protect the public from exposure to *Giardia lamblia* and *Cryptosporidium*
- D. To promote routine surveillance of distribution system water quality to search for fecal matter and/or disease-causing bacteria

\*AWWA, Chapter 1

Head is measure in?

- A. Absolute pressure
- B. Gauge pressure
- C. Feet
- D. Foot-pounds

\*AWWA, Chapter 3 – Water Use and System Design

A plat is?

- A. A map
- B. A corrosion point on a pipe
- C. An organelle found in some protozoans
- D. A highly corrosive soil type

\*AWWA, Chapter 3

At which time of the day is the age of the water stored in the distribution system the highest?

- A. Early morning
- B. Late morning
- C. Early afternoon
- D. Late evening

\*AWWA, Chapter 3

Water mains should primarily be sized based on?

- A. Earthquake size potential
- B. Peak domestic and commercial demands
- C. Peak commercial and industrial demands
- D. Adequate fire flow at an appropriate pressure

\*AWWA, Chapter 3

The most desirable residential pressure ranges from?

- A. 20 to 35 psi (138 to 241 kPa)
- B. 35 to 50 psi (241 to 345 kPa)
- C. 50 to 75 psi (345 to 517 kPa)
- D. 75 to 90 psi (517 to 621 kPa)

\*AWWA, Chapter 3

Domestic water use includes water that is supplied to residential areas, \_\_\_\_\_, and institutional facilities.

- A. Public parks
- B. Commercial districts
- C. Industrial facilities
- D. Municipal buildings

\*AWWA, Chapter 3

Riparian doctrine is sometime called the "rule of \_\_\_\_\_"?

- A. First come, first serve
- B. Reasonable sharing
- C. Equal use
- D. Eminent domain

\*AWWA, Chapter 3

The highest degree of protection for the exterior of a coated steel pipe is?

- A. Cathodic protection
- B. Bituminous materials
- C. Plastic coatings
- D. Polyethylene tapes

\*AWWA, Chapter 5 - Pipe

The C value is a measure of a pipe wall's \_\_\_\_\_.

- A. Smoothness
- B. Smoothness, which allows even flow
- C. Smoothness, which retards turbulent flow
- D. Roughness, which retards flow due to friction

\*AWWA, Chapter 5

Which of the following is a type of joint for ductile iron piping?

- A. Expansion joint
- B. Push-on joint
- C. Bell and spigot with rubber O-ring
- D. Rubber gasket joint

\*AWWA, Chapter 5

What is the term for a sudden repeated increase and decrease in pressure that continues until dissipated by friction losses?

- A. Pipe knocking
- B. Water hammer
- C. Pipe shear
- D. Beam breakage

\*AWWA, Chapter 5

Which of the following is *not* a type of joint generally used today for connecting DIP and fittings?

- A. Push-on joint
- B. Flanged joint
- C. Riveted joint
- D. Mechanical joint

\*AWWA, Chapter 5

When PVC pipe is stacked loose, it should not be stacked more than how high?

- A. 2.0 feet
- B. 3.0 feet
- C. 5.0 feet
- D. 7.5 feet

\*AWWA, Chapter 6 – Water Main Installation and Rehabilitation

What is the most common cause for pipe joint failure (leaking) in newly laid pipe?

- A. The use of a cracked gasket
- B. Not pushing the spigot end the full distance into the bell
- C. Not having the joint completely clean
- D. An incorrect trench bedding angle

\*AWWA, Chapter 6

The backfill material for a pipe installation should contain enough \_\_\_\_\_ to allow for thorough compaction.

- A. Moisture
- B. Sand
- C. Gravel
- D. Mixed sizes

\*AWWA, Chapter 6

What is the approximate angle of repose for average soils when using the sloping method for the prevention of cave-ins?

- A. 0.5:1.0
- B. 1.0:1.0
- C. 1.5:1.0
- D. 2.0:1.0

\*AWWA, Chapter 6

Which of the following statements is true regarding unloading gaskets?

- A. Always have gaskets as near the trench as possible for easy installation
- B. Always store gaskets in a clean, secure location until needed
- C. Store gaskets near electric motors or other operating equipment
- D. Don't worry about getting gaskets dirty while unloading, as long as they're cleaned before installation

\*AWWA, Chapter 6

Whenever a water main crosses a sewer line, the water main should be at least \_\_\_\_\_ above the sewer line?

- A. 12 inches (0.3 m)
- B. 18 inches (0.45 m)
- C. 24 inches (0.61 m)
- D. 30 inches (0.76 m)

\*AWWA, Chapter 6

If an excavation on a road requires that one of the lanes be closed and the speed limit is 25 mph, how many cones are required to divert the traffic?

- A. 6
- B. 9
- C. 13
- D. 15

\*AWWA, Chapter 7 – Backfilling, Main Testing, and Installation Safety

Which of the following is *not* generally a process used for compacting the pipe embedment and backfill placed in a trench?

- A. Tamping
- B. Vibrating
- C. Saturating with water
- D. Sifting

\*AWWA, Chapter 7

Leakage is defined as the volume of water that must be added to the full pipeline to maintain a specified test pressure within a \_\_\_\_ range.

- A. 10-psi (69-kPa)
- B. 5-psi (34-kPa)
- C. 3-psi (21-kPa)
- D. 12-psi (83-kPa)

\*AWWA, Chapter 7

Which of the following is *not* one of the commonly used methods of applying disinfectant?

- A. Stream method
- B. Slug method
- C. Tablet method
- D. Continuous feed method

\*AWWA, Chapter 7

Under any soil conditions, cave-in protection is required for trenches or excavations \_\_\_\_ deep or more.

- A. 15 ft (4.6 m)
- B. 10 ft (3.0 m)
- C. 5 ft (1.5 m)
- D. 2 ft (0.6 m)

\*AWWA, Chapter 7

A corporation stop is used for a?

- A. Service line
- B. Pump discharge line
- C. Tank inlet
- D. Tank outlet

\*AWWA, Chapter 8 – Water Services

Compression fittings used with copper or plastic tubing seal by means of?

- A. A beveled sleeve
- B. A compression ring
- C. A compressed beveled gasket
- D. Compressed O-rings located at either end of the fitting's beveled neck

\*AWWA, Chapter 8

Water meter pits are usually in?

- A. Areas where flooding will most likely occur
- B. Areas where flooding is very rare
- C. Cold climates
- D. Hot climates

\*AWWA, Chapter 8

Which of the following is *not* an advantage of installing meters outside in boxes?

- A. In areas where ground frost is nominal, a meter box can be relatively small, inexpensive, and easy to install
- B. If the boxes can always be readily located, meter boxes can make meter reading easier because meter readers do not have to enter a building
- C. In areas where there is deep frost, meter pits are much more expensive to construct
- D. Placing meters outside eliminates the need to enter buildings to replace meters, which is difficult in some inside locations

\*AWWA, Chapter 8

Other utilities will allow installation of a meter in a crawl space or utility closet as long as (1) the meter can be easily accessed by a meter reader or (2) \_\_\_\_?

- A. The meter is equipped with a remote reading device
- B. The homeowner can easily access and report the meter readings
- C. The meter can self-report to the utility
- D. Water fees in the area are fixed and readings are unnecessary

\*AWWA, Chapter 8

Which type of valve should be installed at a dead-end water main?

- A. Vacuum valve
- B. Air valve
- C. Blowoff valve
- D. Pressure-relief valve

\*AWWA, Chapter 9 - Valves

Which type of valve operates similar to a diaphragm valve?

- A. Vacuum relief valve
- B. Globe valve
- C. Pressure-relief valve
- D. Butterfly valve

\*AWWA, Chapter 9

Which type of valve can go from fully open to fully closed with a quarter turn?

- A. Plug valve
- B. Needle valve
- C. Globe valve
- D. Pinch valve

\*AWWA, Chapter 9

Foot valves are a special type of \_\_\_\_.

- A. Relief valve
- B. Control valve
- C. Check valve
- D. Plug valve

\*AWWA, Chapter 9



Which type of valve would be best to use to precisely throttle flow?

- A. Globe valve
- B. Butterfly valve
- C. Rotary valve
- D. Needle valve

\*AWWA, Chapter 9

Which type of valve is used to isolate a pump on the suction side?

- A. Butterfly valve
- B. Globe valve
- C. Gate valve
- D. Ball valve

\*AWWA, Chapter 9

When fully opened, which type of valve will have the highest head loss?

- A. Gate valve
- B. Plug valve
- C. Globe valve
- D. Ball valve

\*AWWA, Chapter 9

Which type of valve will prevent the collapse of a pipe?

- A. Pressure-relief valve
- B. Needle valve
- C. Pinch valve
- D. Air-and-vacuum relief valve

\*AWWA, Chapter 9

It is standard practice to install fire hydrants on mains with diameters of \_\_\_ or larger.

- A. 6 inch (150 mm)
- B. 8 inch (200 mm)
- C. 10 inch (250 mm)
- D. 12 inch (300 mm)

\*AWWA, Chapter 10 – Fire Hydrants

Most water systems use hydrants with two \_\_\_-diameter nozzles and one \_\_\_-diameter nozzle.

- A. 2.0 inch (51-mm); 3.0 inch (76-mm)
- B. 2.0 inch (51-mm); 4.0 inch (102-mm)
- C. 2.5 inch (64-mm); 3.5 inch (89-mm)
- D. 2.5 inch (64-mm); 4.5 inch (114-mm)

\*AWWA, Chapter 10

Miscellaneous use of fire hydrants is \_\_\_\_\_.

- A. Never authorized
- B. At the public's discretion on an as-needed basis
- C. Generally discouraged but may be authorized in a controlled context
- D. A useful way of testing hydrants indirectly

\*AWWA, Chapter 10

Which of the following is *not* a common classification of fire hydrants?

- A. Flow hydrant
- B. Warm-climate hydrant
- C. Wet-barrel hydrant
- D. Dry-barrel hydrant

\*AWWA, Chapter 10

The lower barrel should be buried in the ground so that the connection to the upper barrel is approximately \_\_\_\_ above the ground line.

- A. 12 inch (300 mm)
- B. 1 inch (25 mm)
- C. 6 inch (150 mm)
- D. 2 inch (50 mm)

\*AWWA, Chapter 10

The height of water in three differently shaped tanks is 22.4 feet. Which tank will have the highest psi at the bottom?

- A. The square tank
- B. The rectangular tank
- C. The cylindrical tank
- D. It will be the same in all three tanks

\*AWWA, Chapter 11 – Water Storage

Which of the following is the proper detention time for disinfecting a water storage tank that is filled with already chlorinated water such that the free chlorine residual is 10 mg/L after the proper detention time is completed?

- A. 4 hours
- B. 6 hours
- C. 8 hours
- D. 24 hours

\*AWWA, Chapter 11

Which of the following is the proper detention time for disinfecting a water storage tank that is mixed with hypochlorite already in the tank such that the free chlorine is 10 mg/L after the proper detention time is complete?

- A. 4 hours
- B. 6 hours
- C. 8 hours
- D. 24 hours

\*AWWA, Chapter 11

In what type of water storage system does water generally “float” on the system?

- A. Elevated storage
- B. Demand storage
- C. Emergency storage
- D. Operating storage

\*AWWA, Chapter 11

The \_\_\_\_ may require the installation of obstruction lights or strobe lights on an elevated tank, depending on its height and location, to warn aircraft in the vicinity.

- A. Occupational Safety and Health Administration
- B. American Water Works Association
- C. Federal Aviation Administration
- D. Federal Communications Commission

\*AWWA, Chapter 11

Which basic electrical unit is used to measure a material’s opposition to the flow of electricity?

- A. Ampere
- B. Ohm
- C. Volt
- D. Joule

\*AWWA, Chapter 12 – Electrical and Instrumentation-and-Control Systems

All sensors that respond to liquid pressure will perform poorly if \_\_\_\_ enter(s) the sensor?

- A. Air
- B. Corrosive chemicals from water treatment processes
- C. Corrosive chemicals from piping
- D. Iron bacteria

\*AWWA, Chapter 12

SCADA systems consist of what distinct components?

- A. Remote terminal units (RTUs), communications, and human-machine interface (HMI)
- B. Sensing instruments, RTUs, communications, and HMI
- C. Sensing instruments, RTUs, communications, master station, and HMI
- D. RTUs, communications, master station, and HMI

\*AWWA, Chapter 12

What is the electronic standard range?

- A. 4 to 20 mA DC
- B. 4 to 20 mA AC
- C. 0% to 100%
- D. 0 to 1 binary

\*AWWA, Chapter 12

The D'Arsonval meter is \_\_\_\_?

- A. An amperometric meter
- B. A type of pH meter
- C. An analog (uses a needle) meter
- D. A digital (number displays on unit) meter

\*AWWA, Chapter 12

Which of the following is *not* an example of a secondary instrument?

- A. Telemetry device
- B. Multiplexing device
- C. pH monitor
- D. Indicator

\*AWWA, Chapter 12

What is the simplest of all AC motors?

- A. Synchronous motor
- B. Squirrel-cage induction motor
- C. Wound-rotor induction motor
- D. Split-phase motor

\*AWWA, Chapter 13 – Motors and Engines

Starters are typically used on motors \_\_\_\_\_.

- A. Larger than fractional horsepower
- B. Of fractional horsepower
- C. Of all horsepower ratings
- D. When gasoline is unavailable

\*AWWA, Chapter 13

In what type of motor is power applied to the winding in such a way that a revolving magnetic field is established?

- A. Synchronous motor
- B. Squirrel-cage induction motor
- C. Wound-rotor induction motor
- D. Split-phase motor

\*AWWA, Chapter 13

Operators should check the idle speed, oil pressure, water temperature, and all other operating indicators \_\_\_\_\_.

- A. Before starting the engine
- B. Exactly one hour after starting the engine
- C. Soon after starting the engine
- D. On an as-needed basis

\*AWWA, Chapter 13

The “heart” of a pump is called the \_\_\_\_\_?

- A. Volute case
- B. Impeller
- C. Motor
- D. Pump

\*AWWA, Chapter 14 – Pumps and Pumping Stations

Which device serves the same function as the packing?

- A. Inline suction gland
- B. Packing gland
- C. Mechanical seal
- D. Lantern seal

\*AWWA, Chapter 14

Which of the following is used to stop air leakage into the casing around a pump shaft?

- A. Packing gland
- B. Lantern ring
- C. Seals
- D. Shaft sleeves

\*AWWA, Chapter 14

Which of the following is at the top of a stuffing box?

- A. Packing gland
- B. Lantern ring
- C. Mechanical seal
- D. Seal cage

\*AWWA, Chapter 14

Which assembly holds the lantern ring and packing?

- A. Shaft assembly
- B. Casing ring assembly
- C. Packing gland casing
- D. Stuffing box

\*AWWA, Chapter 14

Which type of valve is used to isolate a pump on the suction side?

- A. Butterfly valve
- B. Globe valve
- C. Gate valve
- D. Ball valve

\*AWWA, Chapter 14

Packing is designed to \_\_\_\_.

- A. Add lubricant to the shaft
- B. Expand and deteriorate with normal use
- C. Protect the shaft
- D. Wear and deteriorate with normal use

\*AWWA, Chapter 14

Why is it so important to monitor the speed of a variable-speed pump?

- A. To prevent excessive temperature from developing
- B. To prevent vibration from developing
- C. To prevent speed oscillation from occurring
- D. To prevent cavitation from occurring

\*AWWA, Chapter 14

Which of the following is *not* a meter type commonly used on water systems?

- A. Proportional
- B. Current
- C. Magnetic
- D. Inverse

\*AWWA, Chapter 15 - Meters

Positive-displacement meters \_\_\_\_ when they are excessively worn?

- A. Do not register
- B. Underregister
- C. Overregister
- D. Register intermittently

\*AWWA, Chapter 15

When using turbine meters, clogging of the wheel's blades can be prevented by installing a(n) \_\_\_\_ ahead of the meter?

- A. Venturi device
- B. Impeller
- C. Strainer
- D. Restrictor

\*AWWA, Chapter 15

What type of meter is used for service where daily use is relatively low but where very high flow rates may be required in an emergency?

- A. Magnetic meter
- B. Detector-check meter
- C. Venturi meter
- D. Compound meter

\*AWWA, Chapter 15

What type of meter is used for customers that have wide variations in water use?

- A. Magnetic meter
- B. Detector-check meter
- C. Venturi meter
- D. Compound meter

\*AWWA, Chapter 15

One of chlorine's advantages is that it \_\_\_\_\_.

- A. Is not influenced much by pH changes
- B. Does not produce chlorinated by-products
- C. Has a persistent residual
- D. Does not cause taste or odor problems

\*AWWA, Chapter 16 – Basic Chlorination

Chlorine gas is \_\_\_\_\_ times heavier than air.

- A. 1.5
- B. 2.5
- C. 3.5
- D. 4.5

\*AWWA, Chapter 16

After a water storage tank has been chlorinated, which bacteriological test must prove negative before the tank is put back into service?

- A. Gram-negative test
- B. HPC test
- C. Coliform test
- D. Chloramine test

\*AWWA, Chapter 16

Sodium hypochlorite (NaOCl) solution is available with \_\_\_\_\_ available chlorine.

- A. 2-5%
- B. 5-20%
- C. 25-50%
- D. 50-70%

\*AWWA, Chapter 16

Booster chlorination is chlorine added \_\_\_\_\_.

- A. In the coagulation mixing chamber
- B. Before the filters
- C. At the clearwell
- D. Somewhere in the distribution system

\*AWWA, Chapter 16

Chlorine cylinders hold \_\_\_\_ of chlorine.

- A. 100 lb (45 kg)
- B. 150 lb (68 kg)
- C. 200 lb (97 kg)
- D. 350 lb (159 kg)

\*AWWA, Chapter 16

Precipitative softening water treatment plants try to end up with distribution system water that is \_\_\_\_?

- A. Slightly scale forming
- B. Moderately scale forming
- C. Neutral
- D. In equilibrium

\*AWWA, Chapter 17 – System Operations

There are two major objectives for drinking water distribution system operational policies : (1) maintain water quality from the point of entry into the distribution system to the point of use and (2) \_\_\_\_\_.

- A. Keep operating expenses under budget
- B. Make sure the customers do not waste water
- C. Educate customers about water safety
- D. Maintain adequate pressure and deliver adequate flow

\*AWWA, Chapter 17

The goal of a well-managed distribution system should be to provide water to customers' taps that has \_\_\_\_ from the point of entry into the system.

- A. Not changed
- B. Gained valuable nutrients
- C. Decreased dramatically in pH
- D. Become better tasting

\*AWWA, Chapter 17

What factor generally determines the need for larger mains?

- A. Fire flow requirements
- B. pH concerns
- C. Potability issues
- D. Number of customers served

\*AWWA, Chapter 17

Which of the following is *not* a major factor in water storage facility design?

- A. Preventing dead zones
- B. Selecting and maintaining the correct materials of construction
- C. Staying under budget to allow for design modifications
- D. Providing adequate and appropriate cathodic protection to prevent or control corrosion

\*AWWA, Chapter 17



Samples to be tested for coliforms are collected in plastic bottles that must contain \_\_\_\_\_.

- A. Sodium thiocarbonate
- B. Sodium thiooxalate
- C. Sodium thiosulfate
- D. Sodium thiocyanate

\*AWWA, Chapter 18 – Water Quality Testing

The volume of a sample for coliform compliance is \_\_\_\_\_?

- A. 100 mL
- B. 200 mL
- C. 300 mL
- D. 0; there is no volume compliance for coliforms

\*AWWA, Chapter 18

If a water sample is not analyzed immediately for chlorine residual, it is acceptable if it is analyzed within \_\_\_\_\_?

- A. 10 minutes
- B. 15 minutes
- C. 20 minutes
- D. 30 minutes

\*AWWA, Chapter 18

The best choice to collect a water sample from a customer's faucet when responding to a complaint would be a \_\_\_\_\_?

- A. Faucet without threads
- B. Faucet that can swivel
- C. Single-lever handle faucet
- D. Faucet with an aerator

\*AWWA, Chapter 18

When measuring for free chlorine residual, which method is the quickest and simplest?

- A. DPD colorimetric method
- B. Orthotolidine method
- C. Amperometric titration
- D. 1,2 nitrotoluene di-amine method

\*AWWA, Chapter 18

What are the correct protective means for backflow-prevention, in order of decreasing effectiveness, are \_\_\_\_\_?

- A. Air gap (AG), vacuum breaker (VB), reduced pressure zone backflow preventer (RPZ), and double check valve assembly (DCVA)
- B. AG, VB, DCVA, and RPZ
- C. AG, RPZ, VB, and DCVA
- D. AG, RPZ, DCVA, and VB

\*AWWA, Chapter 19 – Backflow Prevention and Cross-Connection Control

What is the likelihood of a swimming pool creating a cross-connection that could contaminate a potable water supply?

- A. Impossible
- B. Not very likely
- C. Moderately likely
- D. Highly likely

\*AWWA, Chapter 19

What is the likelihood of a sewage pump creating a cross-connection that could contaminate a potable water supply?

- A. Impossible
- B. Not very likely
- C. Moderately likely
- D. Highly likely

\*AWWA, Chapter 19

What type of backflow preventer consists of two spring-loaded check valves with a pressure-regulated relief valve located between them?

- A. Vacuum breaker
- B. Atmospheric vacuum breaker
- C. Double check valve backflow preventer
- D. Reduced pressure zone backflow preventer

\*AWWA, Chapter 19

What is the utility's first line of defense against potential legal liability in case of public health problems resulting from a cross-connection?

- A. Notifying the public
- B. Maintaining complete records
- C. Testing the problem
- D. Correcting the issue

\*AWWA, Chapter 19

Which types of maps should not overlap each other?

- A. Index maps
- B. Comprehensive maps
- C. Construction maps
- D. Sectional maps

\*AWWA, Chapter 20 – Information Management and System Mapping

Comprehensive maps of medium to large systems generally have scales ranging from?

- A. 250-500 feet to 1 inch
- B. 500-1,000 feet to 1 inch
- C. 1,000-1,500 feet to 1 inch
- D. 1,500-2,000 feet to 1 inch

\*AWWA, Chapter 20

Sectional maps generally have scales ranging from?

- A. 50-100 feet to 1 inch
- B. 100-200 feet to 1 inch
- C. 200-250 feet to 1 inch
- D. 250-400 feet to 1 inch

\*AWWA, Chapter 20

A comprehensive map should be \_\_\_\_\_?

- A. Compact enough to fit in a folder
- B. As large as possible
- C. As detailed as possible
- D. Written in technical language so that only engineers can read it

\*AWWA, Chapter 20

On a plan and profile drawing, what does the abbreviation EL mean?

- A. English language
- B. Estimated length
- C. Electric
- D. Elevation

\*AWWA, Chapter 20

If an excavation on a road requires that one of the lanes be closed and the speed limit is 25 mph, how many cones are required to divert the traffic?

- A. 6
- B. 9
- C. 13
- D. 15

\*AWWA, Chapter 21 – Safety, Security, and Emergency Response

If an excavation on a road requires that one of the lanes be closed and the speed limit is 45 mph, how many cones are required to divert the traffic?

- A. 9
- B. 13
- C. 15
- D. 18

\*AWWA, Chapter 21

Who is responsible for maintaining safe working conditions?

- A. Upper management
- B. Operations personnel
- C. Supervisors
- D. All water utility personnel

\*AWWA, Chapter 21

What item should be worn whenever a worker is in a trench or has someone working above them, or when they are near electrical equipment?

- A. Gloves
- B. A hardhat
- C. Respiratory equipment
- D. A reflective vest

\*AWWA, Chapter 21

When lifting a load that is too heavy or too large to lift comfortably, \_\_\_\_?

- A. Get a firm hold on the object before lifting
- B. Bend at the knees and lift with the legs
- C. Use a mechanical device to assist in lifting heavy objects
- D. Maintain good footing, with feet about shoulder-width apart, while lifting

\*AWWA, Chapter 21

Which of the following is *not* an example of an accidental disaster that might disrupt water utilities?

- A. Earthquake
- B. Chemical spill
- C. Fire
- D. Transportation accident

\*AWWA, Chapter 21

\_\_\_\_ generally presents the greatest exposure to the public and can have the greatest impact in ensuring public confidence?

- A. Formal media campaigns
- B. Water distribution personnel
- C. Large-scale public relations projects
- D. Political campaigns

\*AWWA, Chapter 22 – Public Relations

\_\_\_\_ should be viewed as an opportunity to improve communications and build goodwill?

- A. The initial customer contact
- B. A response to a customer complaint
- C. Every customer contact
- D. A meter reading

\*AWWA, Chapter 22

If damage to a customer's property occurs, \_\_\_\_?

- A. Customers should be told how to repair the damage
- B. Customers should be put in touch with a professional who can repair the damage
- C. It is the customer's responsibility to repair the damage
- D. Property must be restored to its original state before workers leave the site

\*AWWA, Chapter 22

Shutoffs should be scheduled \_\_\_\_\_?

- A. At the utilities convenience
- B. During holidays
- C. On weekends
- D. To coincide with low-water-use hours

\*AWWA, Chapter 22

What is the general rule for talking to reporters?

- A. Don't do it
- B. Keep answers brief
- C. Make only positive statements
- D. Validate all statements with relevant statistics

\*AWWA, Chapter 22