



Water Center Tennessee Tech University

Justin Murdock

Center Director and Professor of
Biology





The Water Center

Established: 1984 by TN legislature

Mission: to support state and federal agencies, communities, and industry in solving water quality, biodiversity, and water security problems and advance water science and engineering through basic and applied research.

The Center supports faculty research, training and mentoring of future water professionals.

WATER CENTER PRIORITIES

- Research - DATA
- Education/training
- Service



Hub for Water Research and Graduate Student Training at Tech

BIODIVERSITY & ECOLOGY

- Sportfish and nongame aquatic species management
- Invasive species
- Conservation genetics and eDNA

WATER SUSTAINABILITY AND SECURITY

- Water quality
- Water treatment
- Ecotoxicology

MODELING AND SIMULATION / TECHNOLOGY DEVELOPMENT

- Hydrology modeling
- Sensor and control system development
- Geospatial mapping and remote sensing
- Large data analytics

State certified commercial drinking water quality laboratory

STATEWIDE INTEGRATION

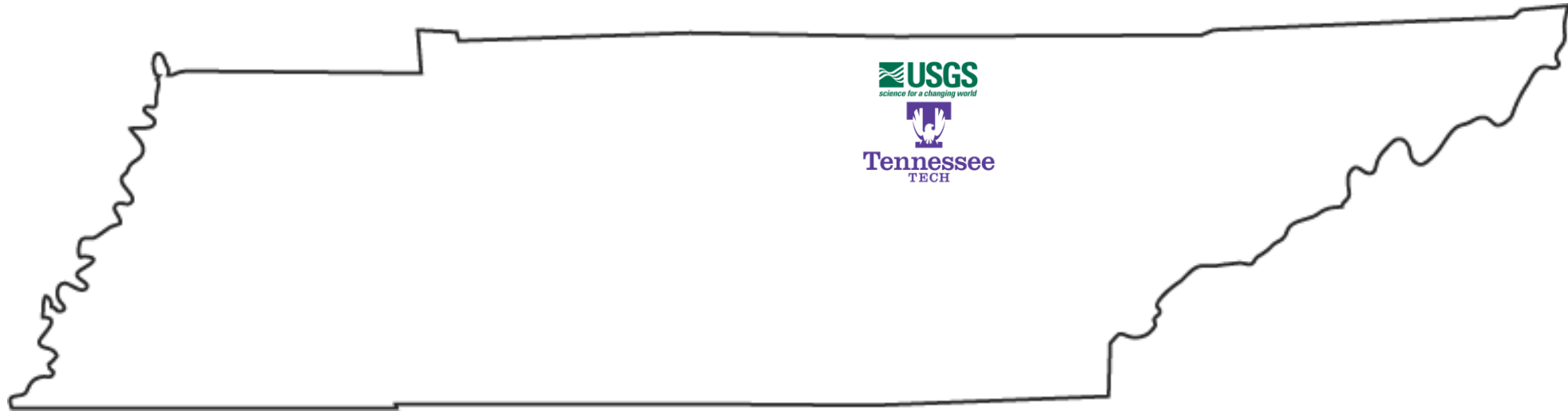

STATEWIDE INTEGRATION

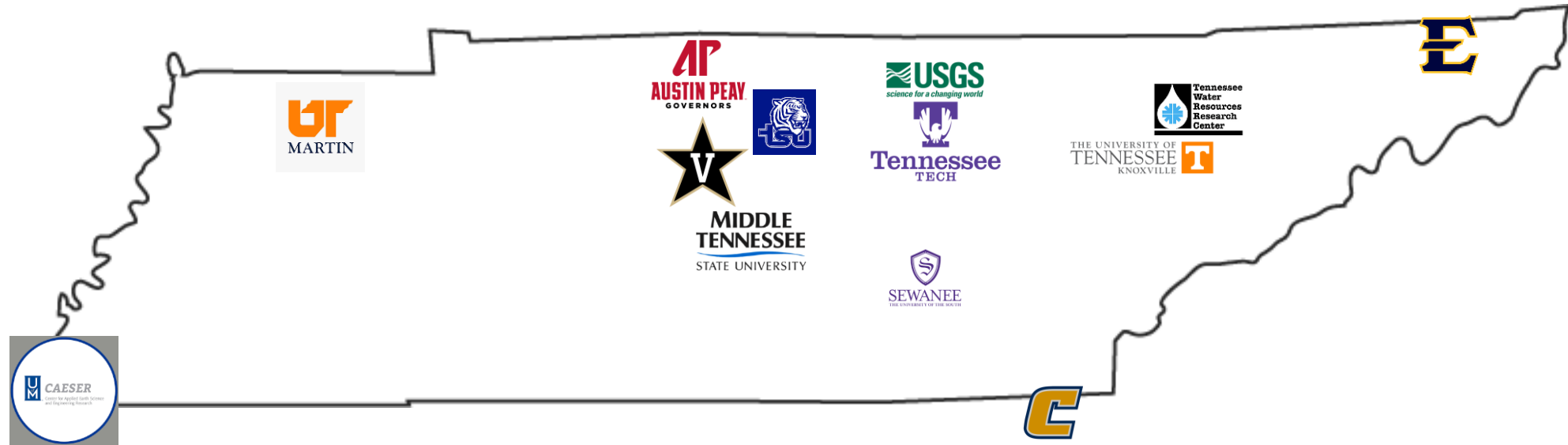

STATEWIDE INTEGRATION

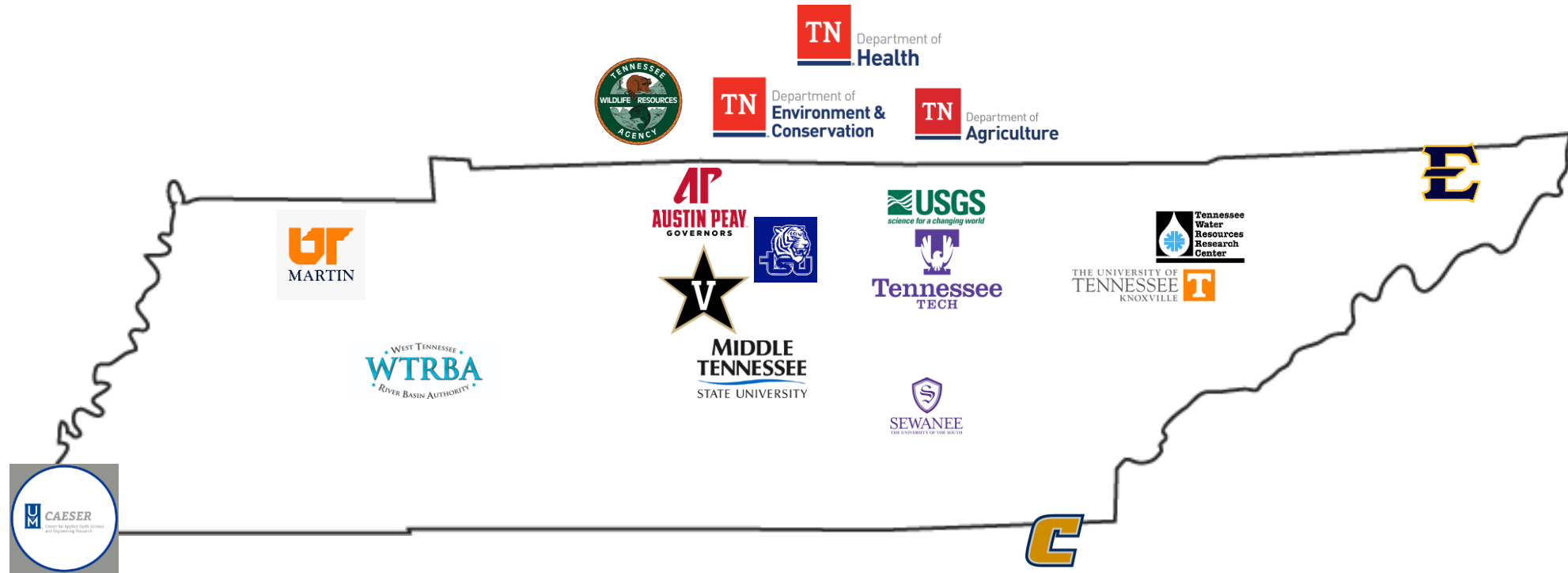

STATEWIDE INTEGRATION

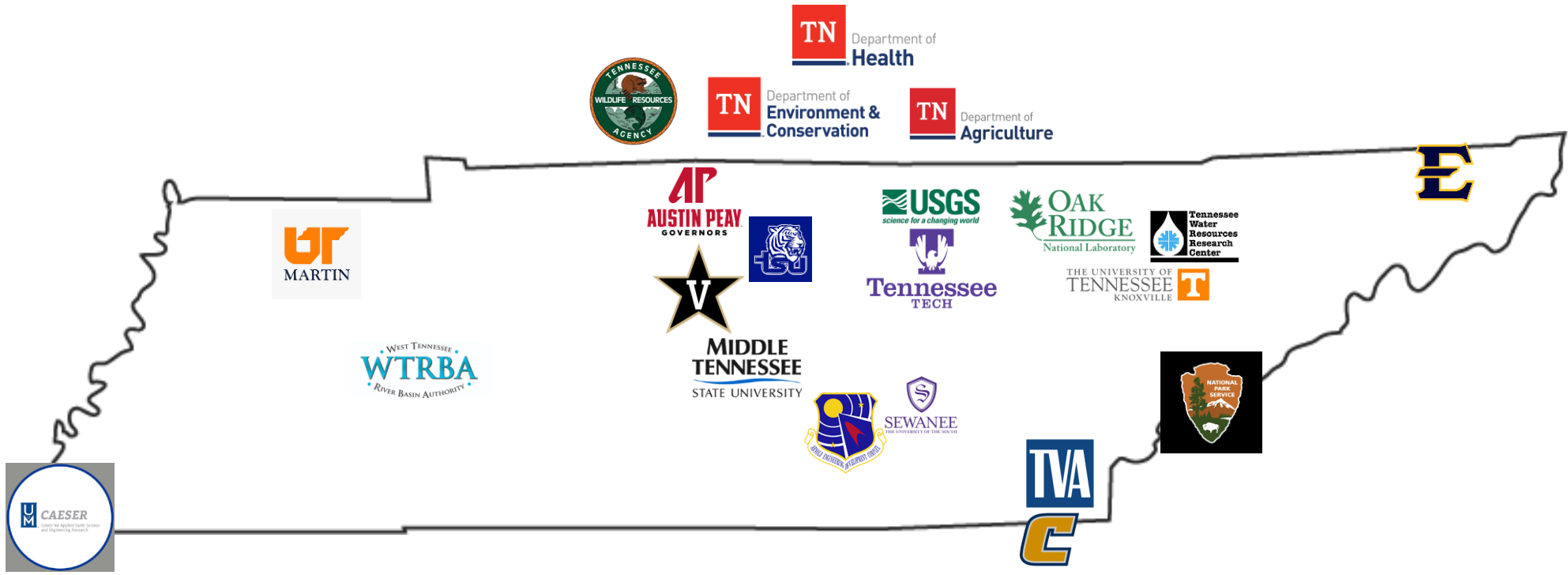

STATEWIDE INTEGRATION

The map of Tennessee is populated with the following logos and organizations:

- USDA** (United States Department of Agriculture)
- U.S. Fish & Wildlife Service**
- USGS** (United States Geological Survey)
- Forest Service** (Department of Agriculture)
- NSF** (National Science Foundation)
- NASA** (National Aeronautics and Space Administration)
- NOAA** (National Oceanic and Atmospheric Administration)
- EPA** (Environmental Protection Agency)
- ERDC** (Engineer Research & Development Center)
- U.S. Department of Energy**
- Tennessee Wildlife Resources Agency**
- TN Department of Health**
- TN Department of Environment & Conservation**
- TN Department of Agriculture**
- UT Martin**
- AP Austin Peay Governors**
- USGS** (science for a changing world)
- Tennessee Tech**
- Oak Ridge National Laboratory**
- Tennessee Water Resources Research Center**
- The University of Tennessee Knoxville**
- WTRBA** (West Tennessee River Basin Authority)
- Middle Tennessee State University**
- Seawanee** (The University of the South)
- TVA** (Tennessee Valley Authority)
- National Park Service**
- Tennessee Aquarium Conservation Institute**
- CAESER** (Center for Applied Earth Science and Engineering Research)
- res** (Resource Environmental Solutions)
- Harpeth Conservancy**
- TWTF** (Tennessee Wildlife Foundation)
- Ducks Unlimited**
- The Nature Conservancy**
- Hazen**

Water Center Research Examples: Duck River



BIODIVERSITY RESEARCH: MUSSELS

No.	Species	Common Name
1	<i>Actinonaias ligamentina</i>	Mucket
2	<i>Actinonaias pectorosa</i>	Pheasantshell
3	<i>Alasmidonta marginata</i>	Elktoe
4	<i>Alasmidonta viridis</i>	Slippershell Mussel
5	<i>Amblema plicata</i>	Threeridge
6	<i>Arcidens confragosus</i>	Rock Pocketbook
7	<i>Cambarunio dactylus</i>	Cumberland River Rainbow
8	<i>Cambarunio taeniatus</i>	Painted Creekshell
9	<i>Cumberlandia monodonta</i>	Spectaclecase
10	<i>Cyclonaias nodulata</i>	Wartyback
11	<i>Cyclonaias pustulosa</i>	Pimpleback
12	<i>Cyclonaias tuberculata</i>	Purple Wartyback
13	<i>Cyprogenia stegaria</i>	Fanshell
14	<i>Ellipsaria lineolata</i>	Butterfly
15	<i>Elliptio crassidens</i>	Elephantear
16	<i>Epioblasma ahlstedti</i>	Duck River Dartersnapper
17	<i>Epioblasma aureola</i>	Golden Riffleshell
18	<i>Epioblasma brevidens</i>	Cumberlandian Combshell
19	<i>Epioblasma florentina</i>	Yellow Blossom
20	<i>Epioblasma obliquata</i>	Catspaw
21	<i>Epioblasma triquetra</i>	Snuffbox
22	<i>Epioblasma turgidula</i>	Turgid Blossom
23	<i>Euryntia dilatata</i>	Spike
24	<i>Fusconaia cuneolus</i>	Finerayed Pigtoe
25	<i>Fusconaia flava</i>	Wabash Pigtoe
74	<i>Truncilla truncata</i>	Deertoe
75	<i>Utterbackia imbecillis</i>	Creeper
76	<i>Utterbackiana suborbiculata</i>	Flat Floater

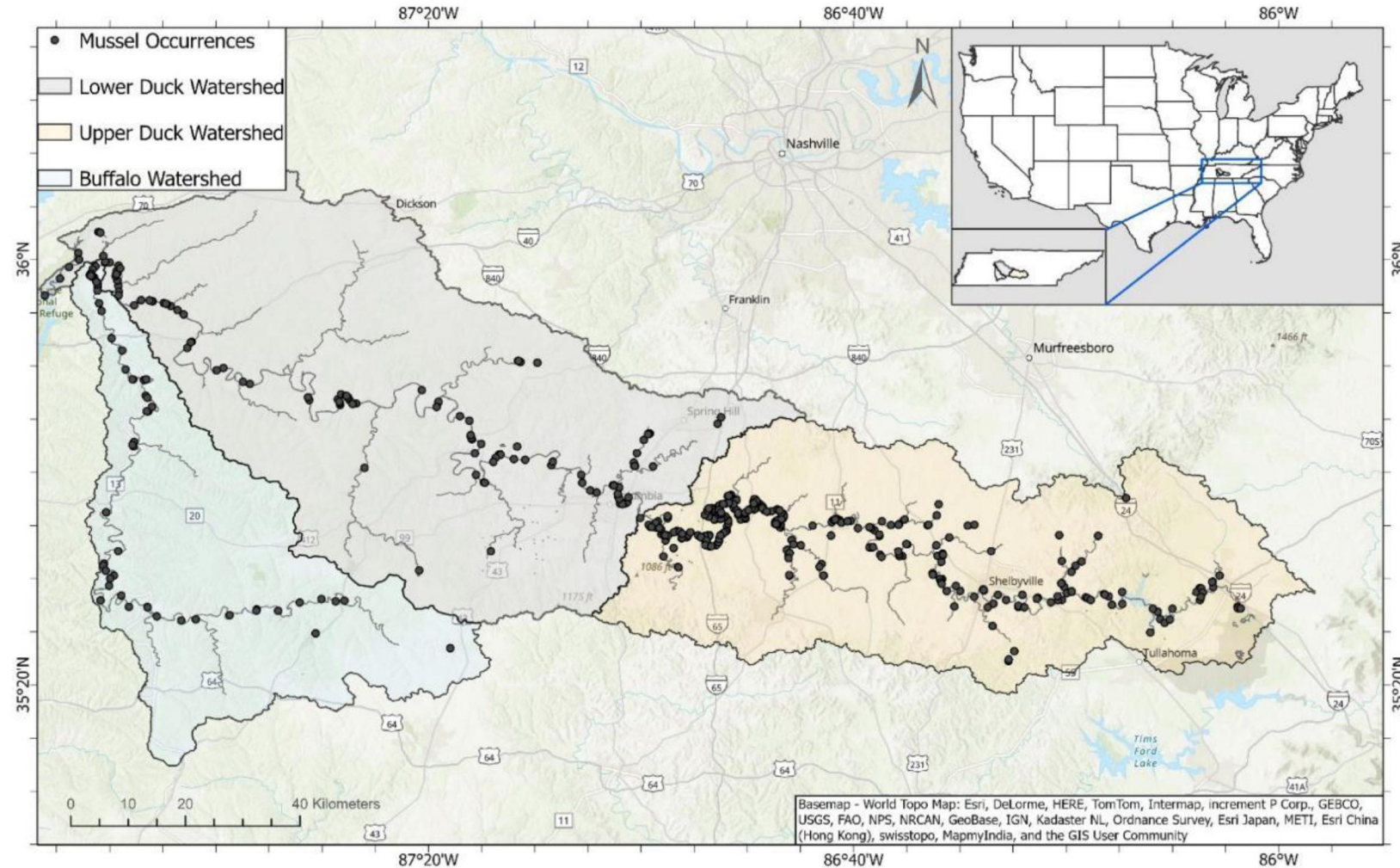

Womble, K.I. and A.E. Rosenberger. 2025. A comprehensive freshwater mussel database for the Duck River Drainage, Tennessee. U.S. Department of Interior, Fish and Wildlife Service, Cooperator Science Series FWS/CSS-166-2025, Washington, D.C. <https://doi.org/10.3996/css36499787Research>

Appendix A1. Map of freshwater mussel collections and observations from the Duck River drainage (1800s-2022). This comprehensive map includes all species and conditions (live, fresh dead, and relic).

BIODIVERSITY RESEARCH: FISHES

2024

SOUTHEASTERN NATURALIST

23(2):259–281

eDNA Illuminates Broader-Than-Expected Distribution of an Imperiled Freshwater Darter Species (Percidae: *Etheostoma striatulum*) in the Duck River, Tennessee

Adam L. Bajo-Walker^{1*}, Kit Wheeler², and Carla R. Hurt²

Abstract - *Etheostoma striatulum* (Striated Darter) is an increasingly rare darter found in the middle-to-upper regions of the Duck River watershed in Tennessee. This rarity,



Population Status and Environmental Associations of the Rare Striated Darter, *Etheostoma striatulum*

ANDREW C. ABERNATHY¹ AND HAYDEN T. MATTINGLY^{2*}

¹Tennessee Stream Mitigation Program, 5000 Lindbar Dr., Suite 265, Nashville, TN 37211 USA

²Department of Biology, Box 5063, Tennessee Technological University, Cookeville, TN 38505 USA

*Corresponding author: hmattingly@tntech.edu

Received: 17 April 2019 | Revised: 5 October 2020 | Accepted: 15 December 2020

DOI: 10.1002/edn3.179

ORIGINAL ARTICLE

Environmental DNA
Dedicated to the study and use of environmental DNA for basic and applied sciences

WILEY

Monitoring a minuscule madtom: Environmental DNA surveillance of the endangered pygmy madtom (*Noturus stanauli* Etnier & Jenkins 1980) in the Duck and Clinch rivers, Tennessee

Robert T. R. Paine¹ | Carla R. Hurt² | Hayden T. Mattingly³



WATER QUALITY RESEARCH

Tennessee Nutrient Database



[Home](#) [About](#)

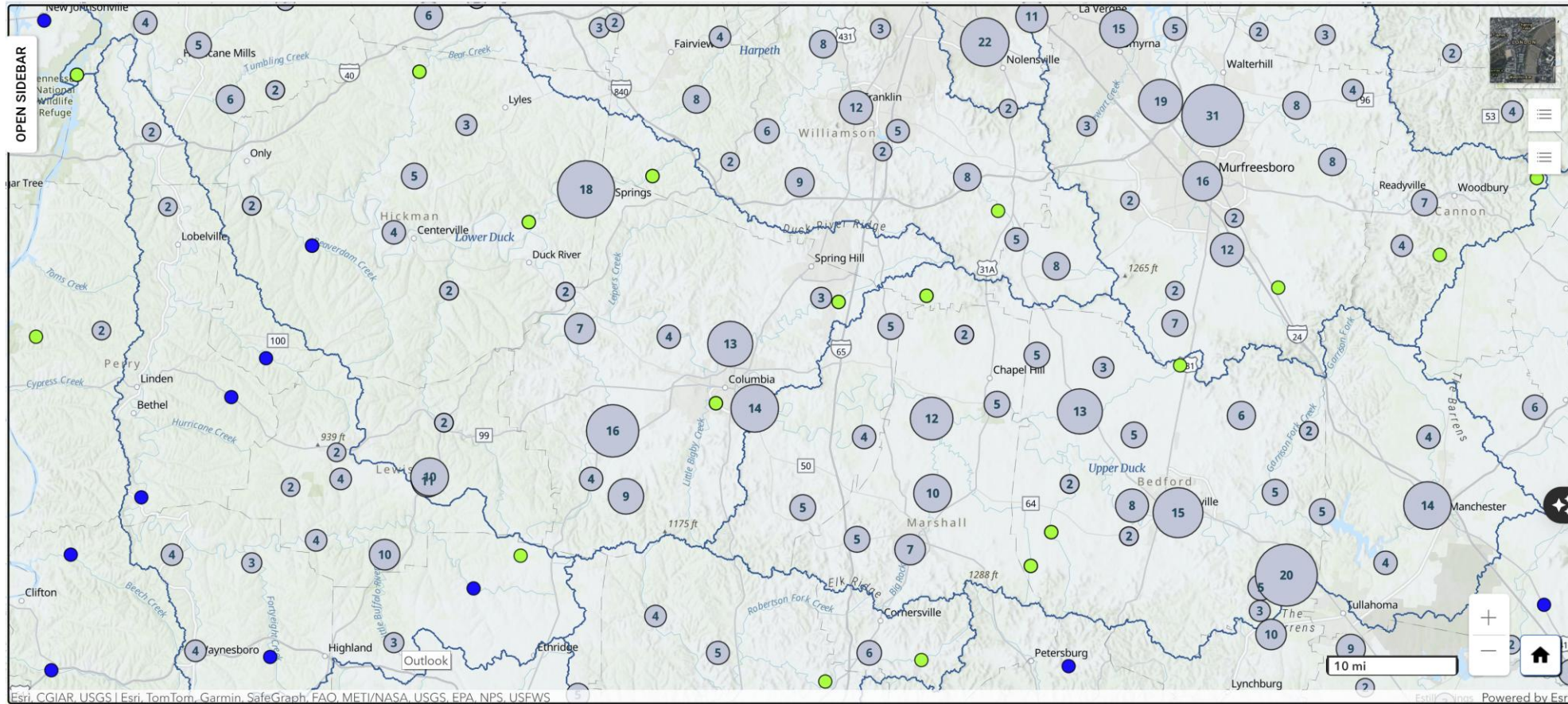

Tania Datta, Grace Tinker, Paul Tinker. Tennessee Nutrient Database. Surface water data 1946-present.

INVASIVE SPECIES RESEARCH

Effects of Asian Carp Invasion on the Food Web of a Mussel Biodiversity Hotspot

in Tennessee



A Final Report Submitted to

Cindy A. Williams

Fish and Aquatic Conservation Program

AIS and FIS Program Coordinator

US Fish & Wildlife Service, Atlanta, Georgia

By

Mark W. Rogers

U.S. Geological Survey, Tennessee Cooperative Fishery Research Unit and Tennessee

Technological University

Cookeville, Tennessee

and

Justin N. Murdock

Silver and Bighead Carp Distribution

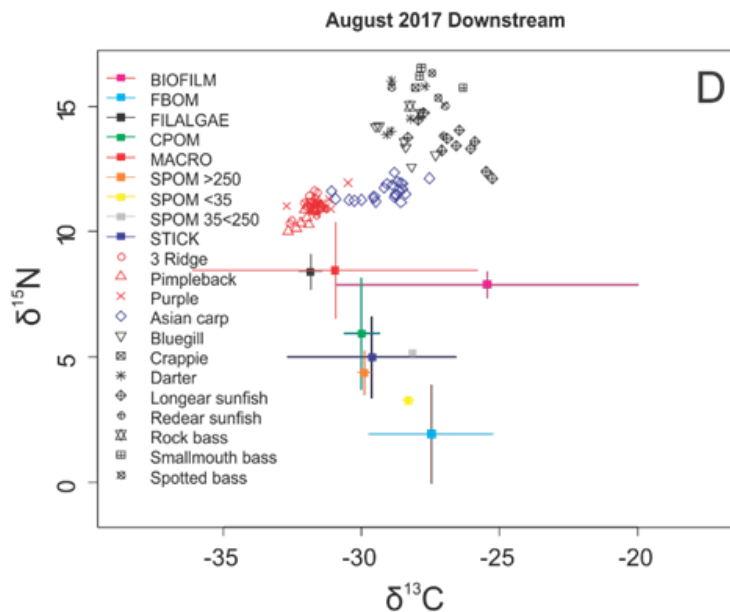
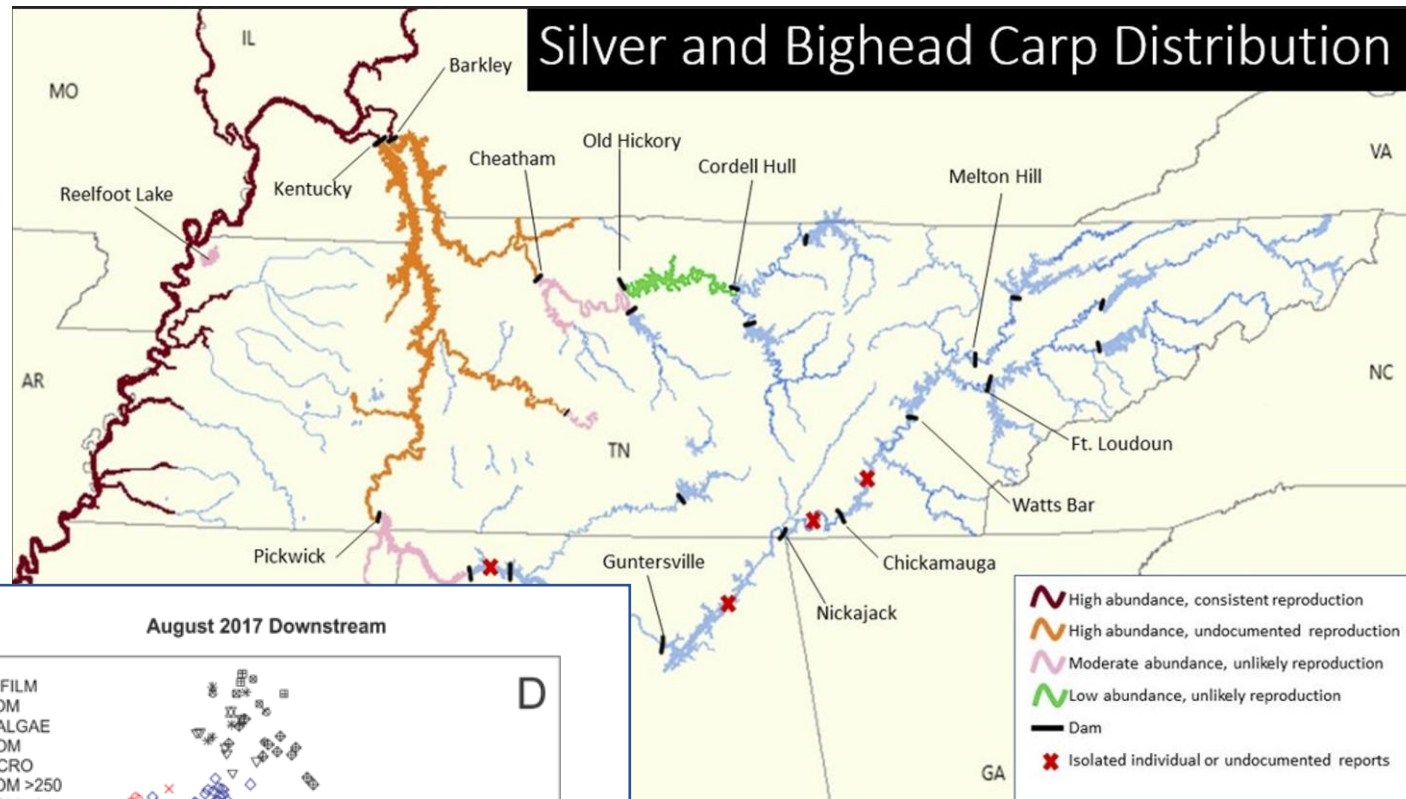

Calfkiller River

Goal: Determine how cross watershed underground pollution may impact endangered fish reintroductions



Andrew Zimmerman Photography ew zimmerman photography

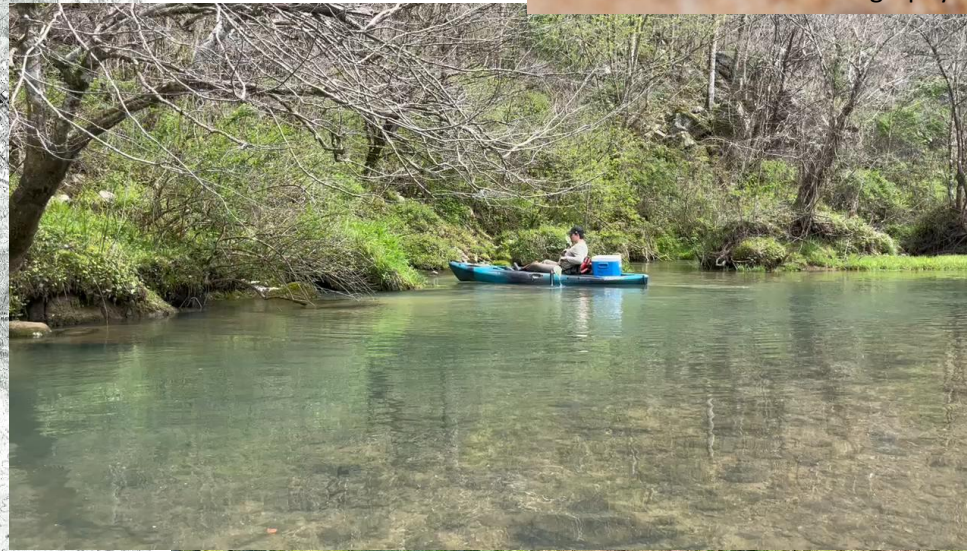
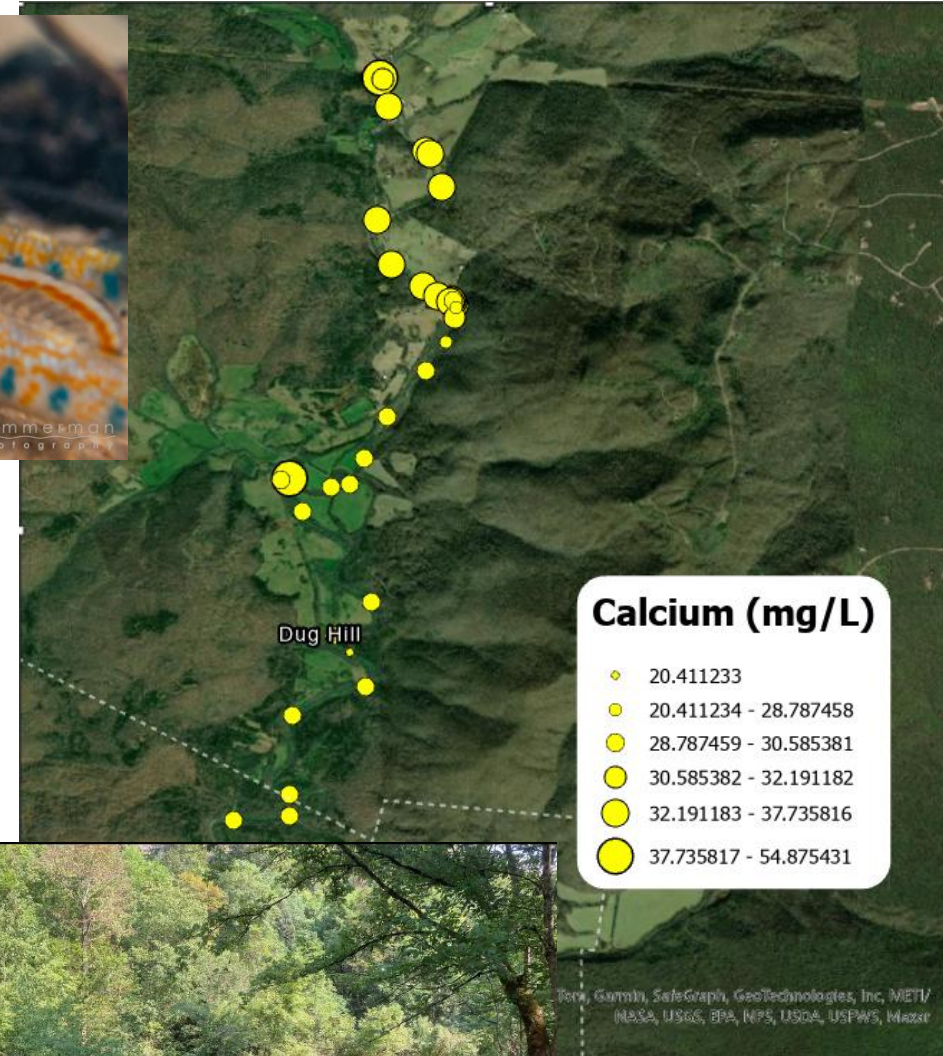

Agricultural Wetlands

Goals:

Measure structural and functional recovery of restored wetlands in the USDA WRP.

Assess restoration practices effectiveness.



University of Missouri



Tennessee
TECH



U.S. Department of Agriculture
Natural Resources Conservation Service

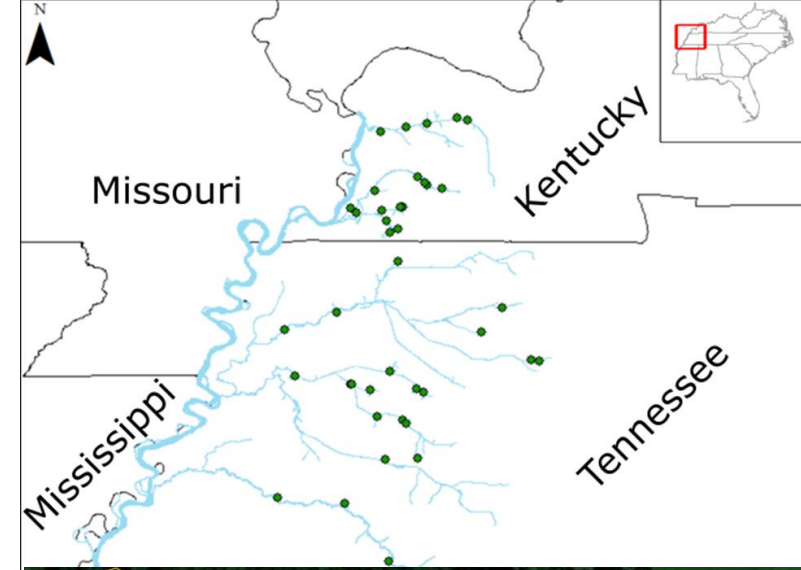

Phosphate Flux

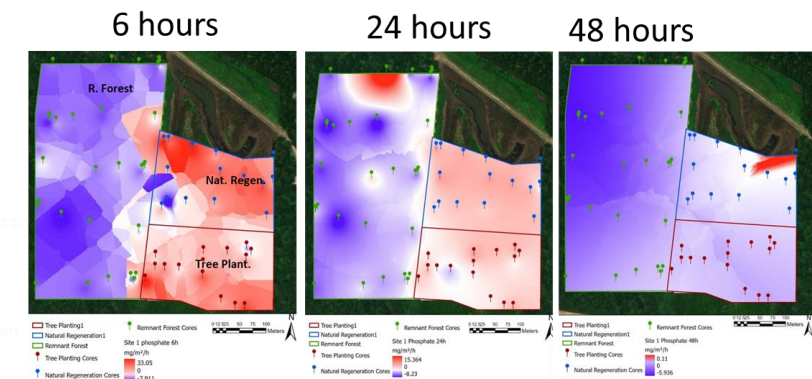

ECOTOXICOLOGY RESEARCH

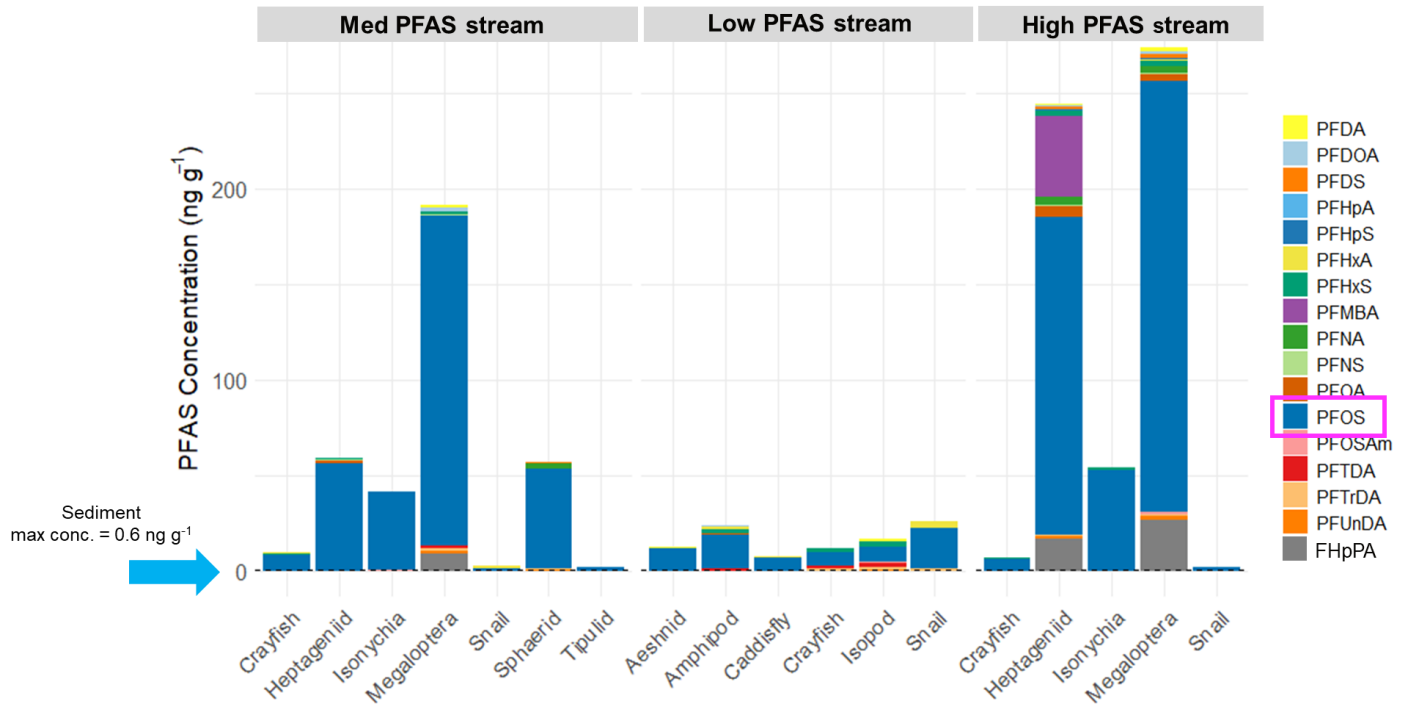

Peter Blum, Justin Murdock. Contaminant transfer from streams to terrestrial consumers

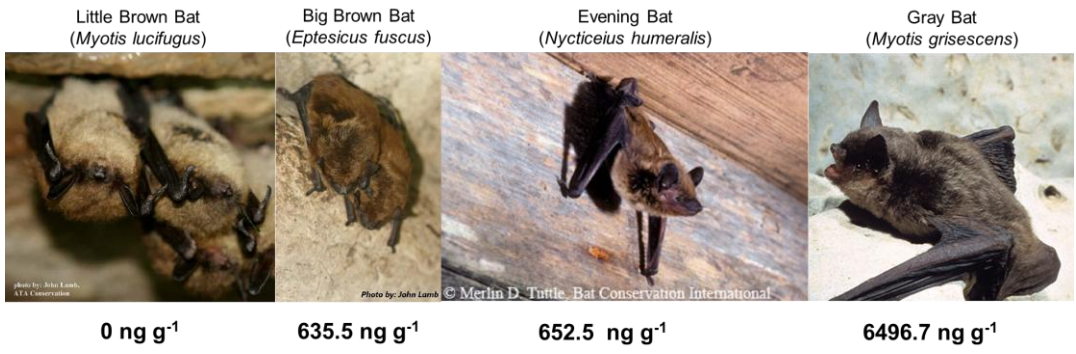

Estimated PFOS concentration in bats

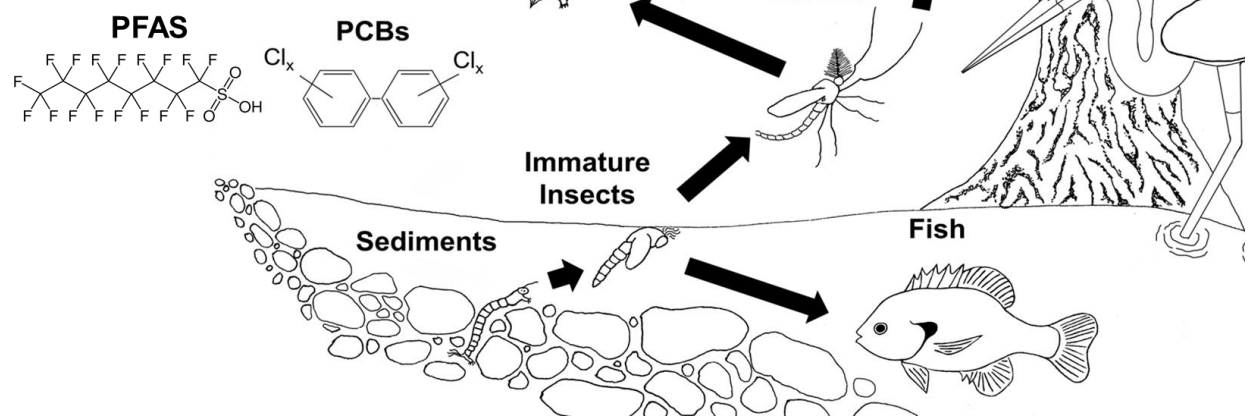

Microplastics



Gabriela De Almeida, an M.S. student under the mentorship of Dr. Tania Datta, is conducting research on the presence and behavior of microplastics in wastewater treatment plants (WWTPs) across Middle Tennessee. The study aims to assess microplastic in both influent and effluent streams, as well as in upstream and downstream sections of the receiving rivers. A key objective is to compare the quantities of microplastics received and discharged by WWTPs with varying design capacities, treatment processes, and operational capabilities, and understand their impact on receiving rivers. In parallel, the team is developing a customized methodology for the collection, processing, and analysis of microplastics in wastewater systems. Gabriela is supported by a team of undergraduate research assistants, including Kayti Gleckler, Braden Waldorf, Krishi Patel, Renae Moore, and others. This project is funded by the Tennessee Department of Environment and Conservation (TDEC). The team's work was recently presented at the 2025 Water Professionals Conference in Knoxville, where their poster earned third place in the student competition.



Emerging Contaminants

An Evaluation of Microplastics in Tennessee's Wastewater Treatment Plants

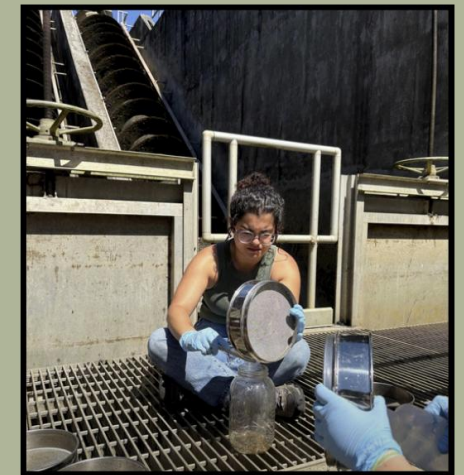

Gabriela De Almeida, graduate student researcher with Dr. Tania Datta.



Gabriela's team sampling at a wastewater treatment plant.

Harmful Algal Blooms

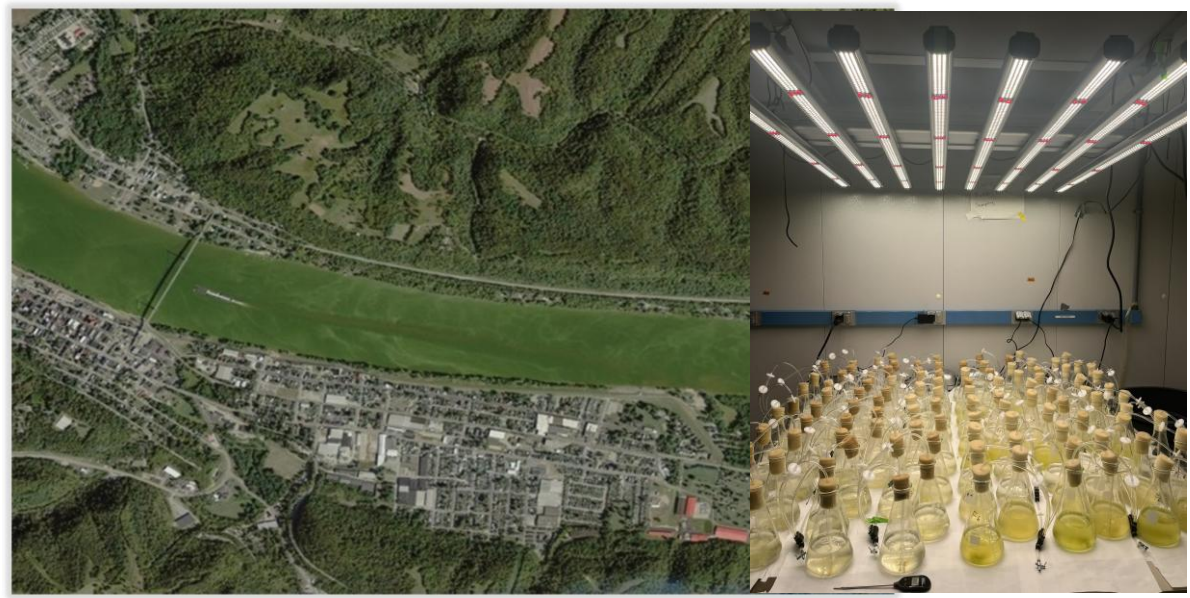

Microcystin

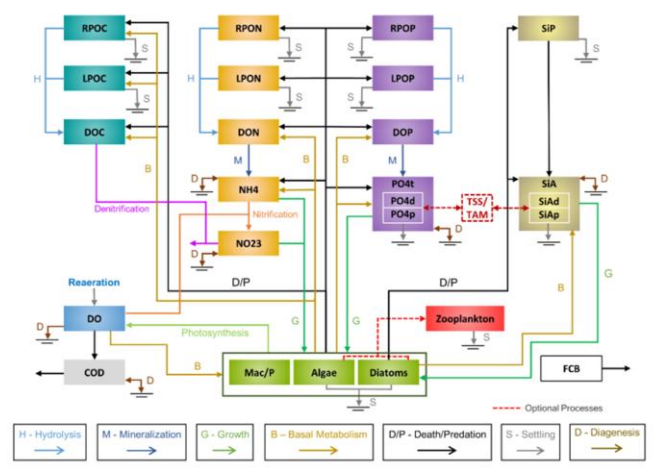
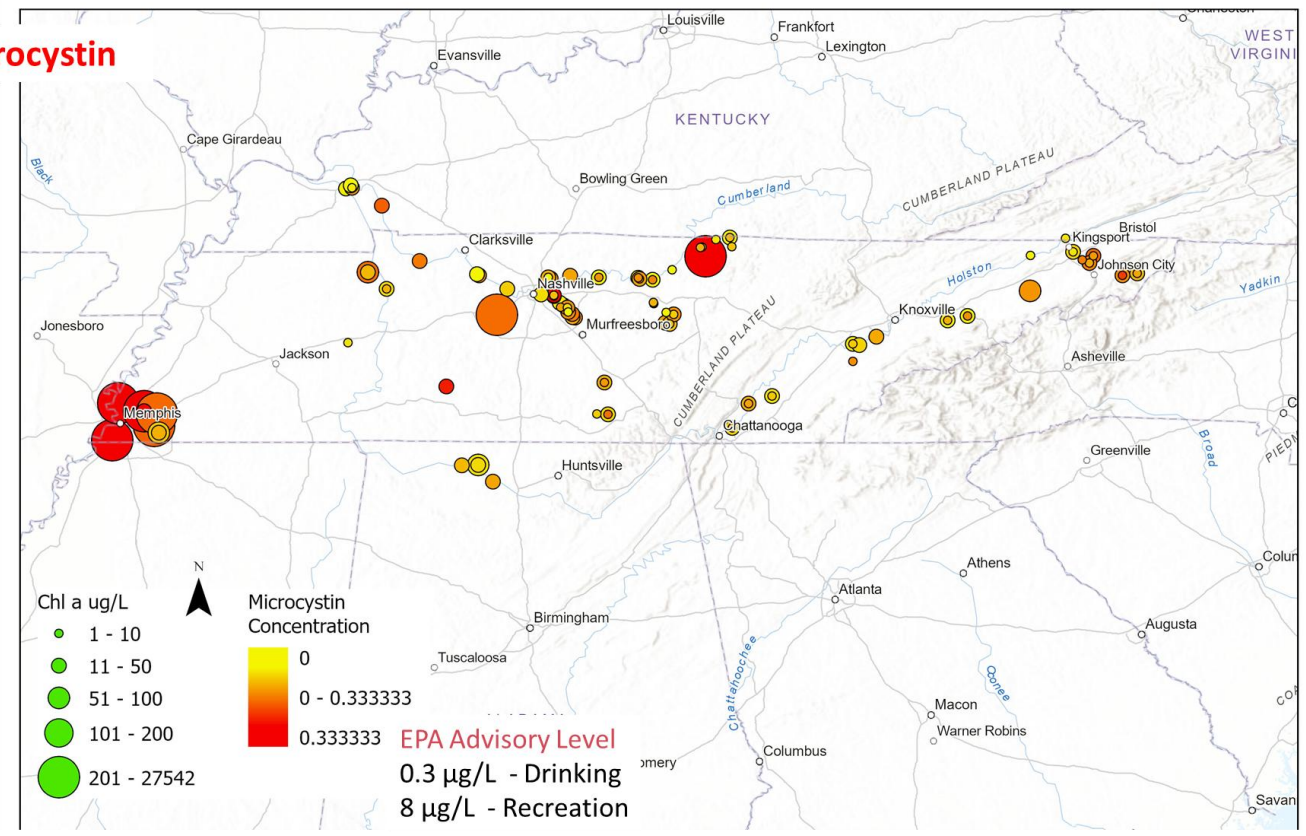

Environmental Fluid Dynamics Code (EFDC+)

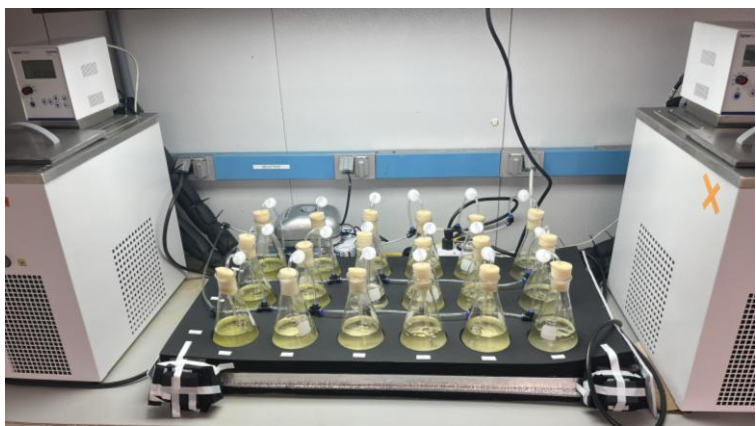

Low-Cost Sensor Systems Development



RESEARCH TRAINING

AN ABSTRACT OF A THESIS

MODELING POTENTIALLY SUITABLE FRESHWATER MUSSEL HABITAT USING REMOTE DATA FOR THE DUCK RIVER DRAINAGE, TENNESSEE

Brittany A. Bajo

Master of Science in Biology

The Duck River in central Tennessee is one of the most species rich systems in all of North America, containing over 100 species of fish and over 50 species of freshwater mussel. Freshwater mussels are generally difficult to detect and often require timely, in-depth surveys

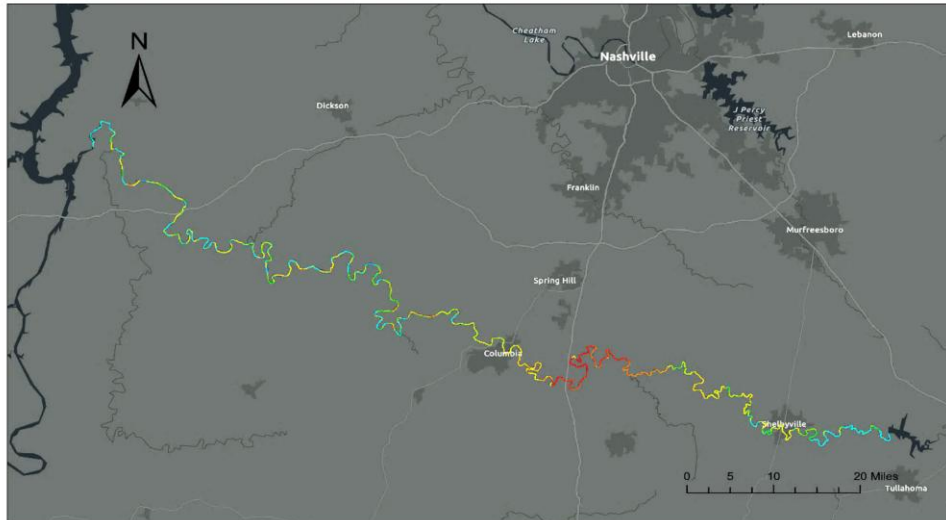

Figure 5. 75THIN Model Results. More than 8 Species ($n = 43$). Choropleth output from MaxEnt. Warmer colors indicate regions most similar to occurrence points, cooler colors indicate regions less similar.

AN ABSTRACT OF A DISSERTATION

A STRATEGIC, EFFICIENT, AND SPATIALLY EXPLICIT MONITORING PROGRAM FOR FRESHWATER MUSSEL COMMUNITIES: A CASE STUDY IN THE MERAMEC BASIN IN MISSOURI



Kayla N. Key

Philosophy Degree in Environmental Sciences

DISTRIBUTION, ABUNDANCE, OCCUPANCY, AND MICROHABITAT USE OF THE STRIATED DARTER (*ETHEOSTOMA STRIATULUM*)

IN THE DUCK RIVER

A Thesis

Presented to

the Faculty of the College of Graduate Studies

Tennessee Technological University

by

Abbey R. Holsopple



AN ABSTRACT OF A THESIS

INVESTIGATION OF CHANNEL CATFISH AND BLUE CATFISH POPULATION DYNAMICS IN THREE TENNESSEE RIVER RESERVOIRS

Cole R. Harty

Master of Science in Biology



Commercial Laboratory



Commercial Bass Genetics Services Tennessee Tech Water Center

<https://www.tntech.edu/research/wrc/>

Contact: Dr. Justin Murdock, jnmurdock@tntech.edu (931) 372-3609

The Water Center at Tennessee Tech University is a research hub that assists state and federal agencies, communities, and industry in solving water quality, biodiversity, and water security problems through basic and applied research. In addition to our state-certified commercial water quality laboratory, we have developed a commercial bass genetics laboratory to receive, process, analyze, and invoice black bass genetic samples with full QA/QC procedures. We employ research staff with genetics expertise to oversee and process samples, but also incorporate student training as part of the procedure. Our goal is to provide quality data with a fast turnaround, and address partner needs.

Bass Genotyping Capabilities

We use the GT-seq SNP Genotyping Platform (Illumina NextSeq 1000) based on species-diagnostic Single Nucleotide Polymorphisms (SNP) markers detailed in Thonga et al. (2020) and the FLB/NLMB panels developed by Li et al. (2014). We provide

- (1) Northern Largemouth (*Micropterus nigricans*) / Florida Largemouth (*M. salmoides*) / F1 identification
- (2) Species assignment and percent ancestry for six black bass species: Largemouth (*M. nigricans*), Smallmouth (*M. dolomieu*), Spotted (*M. punctulatus*), Alabama (*M. henshalli*), Coosa (*M. coosae*), and Shoal (*M. cataractae*).

Lab Capabilities

The Water Center offers unique analytical capabilities through its state-certified water quality lab, which has served homeowners, businesses and the research community in Tennessee and specifically the Upper Cumberland region for over 40 years.



Services:

- Drinking water, wastewater, and stormwater sampling, characterization studies and treatability studies
- Flow and water quality analysis for streams and watersheds
- Chlorophyll analysis
- Microbial source tracking
- Microplastics characterization and quantification
- Geospatial analysis

Analytical Capabilities:

- Trace/heavy metals, anions, and solids
- BOD, COD, TOC
- Bacteria (E. coli and total coliform)
- Dissolved oxygen, conductivity, and pH
- Cyanide
- Oil and grease
- Nutrients
- Chlorophyll
- Algal toxins

Field Sampling & Monitoring Capabilities:

- SonTek ADP: stream velocity measurements, stream bed profiles and total flow
- Datasondes: log of water quality including DO, pH, temperature, conductivity, ORP
- GIS capabilities
- Discrete and composite autosampling
- Assistance with developing sampling strategies, including identifying appropriate analyses

About the Lab:

- State-certified for drinking water parameters
- Enforces a quality control program that conforms to EPA standards
- Offers in-depth assistance when more than just analytical test results are needed
- Supported by the expertise of the Tennessee Tech research community

The lab currently staffs Phillip Burr as the Commercial Lab Manager, Dr. Grace Tinker as the Research/Projects Lab Manager, Alex O'Neal as a Lab Analyst, and Macey Warren as a Lab Technician.