



**LEAD  
HAZARD  
PROGRAM**

# Lead Abatement Activities Compliance Guide Notebook

**STATE OF TENNESSEE**  
DEPARTMENT OF ENVIRONMENT AND CONSERVATION  
Division of Solid Waste Management  
**LEAD HAZARD PROGRAM**



# **Lead-based Paint Activities Compliance Guidebook**



STATE OF TENNESSEE  
DEPARTMENT OF ENVIRONMENT AND CONSERVATION  
DIVISION OF SOLID WASTE MANAGEMENT  
**LEAD HAZARD PROGRAM**

## **ACKNOWLEDGMENTS and DISCLAIMERS**

The *Compliance Guide Notebook* was developed by the Tennessee Department of Environment and Conservation (TDEC) Lead Hazard Program based on collaboration with the Ohio Department of Health Lead Poisoning Prevention Program. Lead Hazard Program staff members thank Dr. Daniel Chatfield and Lisa Zumstein for their assistance and support.

This *Compliance Guide Notebook* is intended to assist lead-based paint certified supervisors, project designers and firms who conduct lead abatement activities in target housing and child-occupied facilities within the State of Tennessee.

The State of Tennessee in citing the information contained in this manual, makes no warranty and assumes no legal liability for the information as presented.

This *Compliance Guide Notebook* was produced with grant funding provided under the Toxic Substances Control Act, Section 404(g), from the U.S. Environmental Protection Agency, Office of Prevention, Pesticides and Toxic Substances.

# TABLE OF CONTENTS

SECTION #	
1	<b>TDEC Division of Solid Waste Management Lead Hazard Program</b> <ul style="list-style-type: none"> <li>• Contact List</li> <li>• Online Resources for Lead Information</li> </ul>
2	<b>Prior Notification Procedures and Application Forms</b>
3	<b>TDEC DSWM Rule Chapter 0400-13-01 Lead Based Paint Activities</b>
4	<b>Occupant Protection and Worksite Preparation</b> <ul style="list-style-type: none"> <li>• Occupant Protection Plan Fillable Template</li> <li>• Rule 0400-13-01-.01 (6)(f)(5) - Occupant Protection Plan Requirements</li> </ul>
5	<b>Model Written OSHA Safety Plan</b> Rule 0400-13-01 (6) - Work Practice Standards for Conducting Lead-Based Paint Activities: Target Housing and Child-Occupied Facilities
6	<b>Model Respiratory Protection Plan</b> <b>U.S. Occupational Safety and Health Regulations for Construction</b> <ul style="list-style-type: none"> <li>• 29 CFR 1926.62 - Lead</li> <li>• 29 CFR 1910.134 - Respiratory Protection Standard</li> </ul>
7	<b>Abatement Reports</b> <ul style="list-style-type: none"> <li>• Lead Abatement Report Fillable Templates</li> <li>• Rule 0400-13-01 (6)(f)(11) - Abatement Report Requirements</li> </ul> <b>HUD Guidelines for the Evaluation and Control of Lead-Based Paint Hazards in Housing (Second Edition, July 2012)</b> <ul style="list-style-type: none"> <li>• <a href="#">Chapter 11: Interim Controls</a></li> <li>• <a href="#">Chapter 12: Abatement</a></li> <li>• <a href="#">Chapter 14: Cleaning</a></li> </ul>
8	<b>Hazard Communication</b> <ul style="list-style-type: none"> <li>• Sample Hazard Communication Program</li> <li>• 29 CFR 1910.1200 - Hazard Communication Standard</li> <li>• OSHA 3111 - Hazard Communication Guidelines for Compliance</li> </ul>

<b>9</b>	<b>Lead Paint Safety: A Field Guide for Painting, Home Maintenance, and Renovation Work - HUD-1779-LHC</b>
<b>10</b>	<b>The National Lead Laboratory Accreditation Program</b> <ul style="list-style-type: none"> <li>• Environmental Accredited Lead Laboratories</li> </ul>
<b>11</b>	<b>State of Tennessee Reciprocity Agreements</b>
<b>12</b>	<b>HUD Guidelines for the Evaluation and Control of Lead-Based Paint Hazards in Housing (Second Edition, July 2012)</b> <ul style="list-style-type: none"> <li>• <a href="#">Table of Contents</a></li> <li>• <a href="#">Chapter 1: Introduction</a></li> <li>• <a href="#">Glossary of Terms</a></li> </ul>
<b>13</b>	<b>Lead Abatement Waste Management Policy</b> <ul style="list-style-type: none"> <li>• Rules Changed to Help Accelerate Lead-based Paint Removal</li> <li>• 40 CFR Parts 257 and 258 - Criteria for Classification of Solid Waste Disposal Facilities and Practices and Criteria for Municipal Solid Waste Landfills: Disposal of Residential Lead-Based Paint Waste</li> </ul>

# **SECTION 1**

**TDEC**  
**Division of Solid Waste Management**  
**Lead Hazard Program**

**Contact List**

**Online Resources for Lead Information**



**STATE OF TENNESSEE**  
**DEPARTMENT OF ENVIRONMENT AND CONSERVATION**  
**Division of Solid Waste Management**  
**7<sup>th</sup> Floor, Davy Crockett Tower**  
**500 James Robertson Parkway**  
**Nashville, Tennessee 37243**

Lead Hazard Program Contact List  
Toll Free (888) 771-LEAD  
Fax: 615-532-0938

<https://www.tn.gov/environment/toxic-substances-program/lead-hazard-program.html>

Adrienne White  
Senior Program Manager  
615-532-0885

[Adrienne.White@tn.gov](mailto:Adrienne.White@tn.gov)

Rule development/amendments, USEPA Liaison, Community Outreach, Research and Special Projects

Pamela Franklin  
Environmental Manager  
615-532-0849

[Pamela.Franklin@tn.gov](mailto:Pamela.Franklin@tn.gov)

Program Management, Enforcement, Regulatory Interpretation, Project Specification Review

Jackie Manuel  
Environmental Manager  
615-532-9291

[Jackie.Manuel@tn.gov](mailto:Jackie.Manuel@tn.gov)

Certification/Accreditation Coordinator, Certification of Individuals, Training Program Approval and Auditing, Reciprocity, Compliance Assistance

Robbyn Smith  
Administrative Services  
615-532-6877

[Robbyn.Smith@tn.gov](mailto:Robbyn.Smith@tn.gov)

Certification/Accreditation Applications, Application Status and Maintenance of Program Information

Rebecca Huntemann  
Environmental Consultant  
615-906-5384

[Rebecca.Huntemann@tn.gov](mailto:Rebecca.Huntemann@tn.gov)

Compliance Inspections, Compliance Assistance, TSCA 406 Pre-Renovation Inspections

Brianna Moyers  
Environmental Scientist  
615-354-3823

[Brianna.Moyers@tn.gov](mailto:Brianna.Moyers@tn.gov)

Compliance Inspections, Compliance Assistance, TSCA 406 Pre-Renovation Inspections

Hunter Waldrep  
Environmental Scientist  
615-913-0482

[Hunter.Waldrep@tn.gov](mailto:Hunter.Waldrep@tn.gov)

Compliance Inspections, Compliance Assistance, TSCA 406 Pre-Renovation Inspections,  
Elevated Blood Lead Level Investigations

Darius Lawson  
Environmental Scientist  
615-253-4134

[Darius.Lawson@tn.gov](mailto:Darius.Lawson@tn.gov)

Compliance Inspections, Compliance Assistance, TSCA 406 Pre-Renovation Inspections

## **Online Resources for Lead Information**

**The State of Tennessee Lead Hazard Program at:**

<https://www.tn.gov/environment/toxic-substances-program/lead-hazard-program.html>

**U.S. EPA Office of Chemical Safety and Pollution Prevention (OCSPP):**

<https://www.epa.gov/aboutepa/about-office-chemical-safety-and-pollution-prevention-ocspp>

**U.S. EPA Lead Information Page**

<https://www.epa.gov/lead>

## **Other Resources for Lead Poisoning Prevention**

**The Centers for Disease Control and Prevention (CDC)** Promotes state and local screening efforts and develops improved treatments for lead exposure.

**The Consumer Product Safety Commission (CPSC)** Identifies and regulates sources of lead exposure in consumer products.

### **CPSC Lead Hazard Recalls**

**The Department of Housing and Urban Development (HUD)** Sets standards for evaluation and management of lead in federally assisted housing, and promotes efforts to reduce lead hazards in privately owned housing. In addition, provides grants to communities to reduce lead hazards in housing.

### **HUD Office of Lead Hazard Control and Healthy Homes**

### **Guidelines for the Evaluation and Control of Lead-Based Paint Hazards in Housing (2012 Edition)**

**The National Conference of State Legislatures (NCSL)** The NCSL Lead Hazards Project assists states on the issue of lead poisoning prevention by facilitating information exchange among the states and by promoting improved coordination between the states and EPA's Office of Pollution Prevention and Toxics.

<https://www.ncsl.org/research/environment-and-natural-resources/lead-hazards-project.aspx>

[The Occupational Safety and Health Administration \(OSHA\)](#) Develops work practice standards and worker exposure limits to protect workers from occupational lead exposure.

<http://www.osha.gov/SLTC/lead/>

# **SECTION 2**

## **Prior Notification Procedures and Application Forms**

**Subject: ON-LINE ELECTRONIC SUBMISSION OF  
LEAD-BASED PAINT ACTIVITY NOTIFICATIONS AND CERTIFICATION APPLICATIONS**  
*Transition to Paperless Submissions*

Firms and individuals are encouraged to use the Tennessee Department of Environment and Conservation's (TDEC) Toxic Substances Program online system, [MyTDEC Forms](#), for submitting applications for lead-based paint (LBP) certification and notifications of LBP activity.

The MyTDEC Forms online portal is designed to:

1. Meet paper reduction goals.
2. Improve the procedures for receiving and validating notifications of LBP activity and applications for certification.
3. Streamline the process for tracking new, revised, and canceled project notifications of LBP activity as well as LBP certification approvals and denials.
4. Facilitate the submission of records, reports, and documents.

To comply with federal identity regulations, each certified firm and individual must register for their own account. Registrations cannot be completed by another person.

**How to Access MyTDEC Forms:**

1. Visit the MyTDEC Forms portal at <https://forms.tdec.tn.gov/>.
2. Follow the step-by-step instructions provided on the website to register a new account.

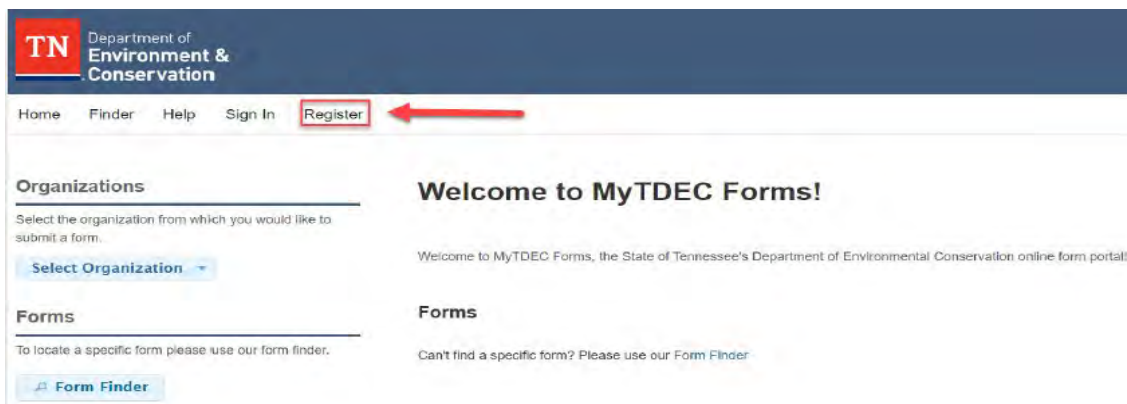

For assistance or to sign up for training on using the MyTDEC Forms portal, please contact the TDEC Toxic Substances Program at [LBP.Notify@tn.gov](mailto:LBP.Notify@tn.gov). Thank you for your cooperation and effort in transitioning to this online submission process.

**Note:** If unable to use MyTDEC Forms online portal, submit the below forms to [LBP.Notify@tn.gov](mailto:LBP.Notify@tn.gov).

## Rule 0400-13-01-.01 Notification Requirements

### (k) Notification.

A certified firm must notify the Commissioner of lead-based paint activities as follows:

1. Except as provided in part 2 of this subparagraph, the Commissioner must be notified prior to conducting lead-based paint activities. The original notification must be received by the Commissioner at least five business days before the start date of any lead-based paint activities.
2. Notification for lead-based paint activities required in response to an elevated blood lead level (EBLL) determination, or federal, State, or local emergency abatement order, should be received by the Commissioner as early as possible before, but must be received no later than, the start date of the lead-based paint activities. Should the start date or location provided to the Commissioner change, an updated notification must be received by the Commissioner on or before the start date provided to the Commissioner. Documentation showing evidence of an EBLL determination or a copy of the federal, state, Tribal, or local emergency abatement order must be included in the written notification to take advantage of this abbreviated notification period.
3. Except as provided in part 2 of this subparagraph, updated notification must be provided to the Commissioner for lead-based paint activities that will begin on a date other than the start date specified in the original notification as follows:
  - (i) For lead-based paint activities beginning prior to the start date provided to the Commissioner, an updated notification must be received by the Commissioner at least five business days before the new start date included in the notification.
  - (ii) For lead-based paint activities beginning after the start date provided to the Commissioner, an updated notification must be received by the Commissioner on or before the start date provided to the Commissioner.
4. Except as provided in part 2 of this subparagraph, updated notification must be provided to the Commissioner for any change in location of lead-based paint activities at least five business days prior to the start date provided to the Commissioner.
5. Updated notification must be provided to the Commissioner when lead-based paint activities are canceled or when there are other significant changes including, but not limited to, when the square footage or acreage to be abated changes by more than 20%. This updated notification must be received by the Commissioner on or before the start date provided to the Commissioner, or if work has already begun, within 24 hours of the change.
6. The following must be included in each notification:
  - (i) Notification type (original, updated, cancellation);
  - (ii) Date when lead-based paint activities will start;
  - (iii) Date when lead-based paint activities will end (approximation using best professional judgment);
  - (iv) Firm's name, certification number, address, and telephone number;
  - (v) Type of building (e.g., single family dwelling, multi-family dwelling, child-occupied facilities) on/in which abatement work will be performed;
  - (vi) Property name (if applicable);

- (vii) Property address including apartment or unit number(s) (if applicable) for abatement work;
  - (viii) If using the abbreviated time period as described in part 2 of this subparagraph, documentation showing evidence of an EBLL determination or a copy of the federal, State, Tribal, or local emergency abatement order;
  - (ix) Name and certification number of the project supervisor;
  - (x) Approximate square footage or acreage to be abated;
  - (xi) Brief description of abatement, risk assessment, inspection, lead hazard screen, lead hazard reduction, and clearance activities to be performed; and
  - (xii) Name, title, and signature of the representative of the certified firm who prepared the notification.
7. Notification must be made by written notification or electronically by such means approved by the Commissioner. Written notification can be accomplished using the Division form titled "Lead-Based Paint Activity Notification," or a successor to that form approved by the Commissioner. All written notification must be delivered by U.S. Postal Service, fax, commercial delivery service, or hand delivery.
8. In the event of changes to the original notification, lead-based paint activities shall not begin on a date or at location other than that specified in either an original or updated notification.
9. No firm or individual shall engage in lead-based paint activities prior to notifying the Commissioner of such activities according to the requirements of this subparagraph.



State of Tennessee  
 Department of Environment and Conservation  
 Division of Solid Waste Management - Toxic Substances Program  
 Davy Crockett Tower, 7th Floor  
 500 James Robertson Parkway  
 Nashville, TN 37243

**APPLICATION TO CONDUCT LEAD-BASED PAINT ACTIVITIES - FIRM**

**Instructions:** Complete and submit the application. Complete all sections of the application in ink. Include all required supporting documentation. Make payments to Treasurer, State of Tennessee by check, money order, or cashier's check - **do not send cash**. Mail application, documentation, and payment to: **State of Tennessee, Department of Environment and Conservation, Division of Fiscal Services - Fee Section, Davy Crockett Tower 7th Floor, 500 James Robertson Parkway, Nashville, TN 37243.**

**Application Fee Non-Refundable:** Applicants will have 30 days from the date of initial receipt of the application to submit any missing information and/or needed documentation to complete the application process. If an applicant fails to respond within 30 days, the application will be canceled, and the applicant will be required to reapply.

**1 - NAME AND ADDRESS**

NAME OF FIRM				FEIN	
<b>IF INDIVIDUAL</b> ▶	FIRST NAME	MIDDLE INITIAL	LAST NAME		SOC SEC NUMBER
	AREA CODE / PHONE NUMBER 1	AREA CODE / PHONE NUMBER 2	AREA CODE / FAX NUMBER	E-MAIL ADDRESS	
STREET / MAILING ADDRESS			CITY	STATE	ZIP

**2 - CALCULATING FEES**

CHECK YOUR SELECTION; ENTER TOTAL IN COLUMN E:	A. INITIAL CERTIFICATION	B. RE-CERTIFICATION	C. ANNUAL RENEWAL	D. 3 YEAR CERTIFICATION	E. TOTAL AMT ENCLOSED
	<input type="checkbox"/> \$500	<input type="checkbox"/> \$500	<input type="checkbox"/> \$300	<input type="checkbox"/> \$1,100	\$ _____

**3 - ENVIRONMENTAL NON-COMPLIANCE ACTIONS** (use additional paper if needed)

HAVE YOU EVER RECEIVED A VIOLATION? IF YES, LIST VIOLATION(S)	STATE(S) OF OCCURRENCE

**4 - CERTIFICATION AND SIGNATURE**

I certify, under penalty of law, that: I am lawfully present in the United States as a U.S. citizen or a qualified alien as defined in 8 U.S.C. §1641(b); this document and all attachments were prepared by me or under my direction or supervision; and, all of the submitted information is, to the best of my knowledge and belief, true, accurate, and complete. I understand that the penalties for providing false information and making false or fraudulent statements or representations may include revocation of the permit, license or accreditation, civil penalties, and/or criminal prosecution resulting in a fine, imprisonment or both. As specified in Tennessee Code Annotated Section 39-16-702(a)(4), this declaration is made under penalty of perjury. I affirm that the work practice standards according to Chapter Rule 0400-13-01 will be followed. I authorize the State of Tennessee to verify any information on or included with this application.

 \_\_\_\_\_

APPLICANT SIGNATURE

\_\_\_\_\_

DATE (mm / dd/ yyyy)

\_\_\_\_\_

PRINTED NAME



State of Tennessee  
 Department of Environment and Conservation  
 Division of Solid Waste Management - Toxic Substances Program  
 Davy Crockett Tower, 7th Floor  
 500 James Robertson Parkway  
 Nashville, TN 37243

OFFICE USE ONLY  
 U.S. EMPLOYMENT STATUS  
 DOCS SUBMITTED  
 MEETS STANDARD

**APPLICATION TO CONDUCT LEAD-BASED PAINT ACTIVITIES - INDIVIDUAL**

**Instructions:** Complete and submit the application. Complete all sections of the application in ink. Include all required supporting documentation. Make payments to Treasurer, State of Tennessee by check, money order, or cashier's check **do not send cash**. Mail application, documentation, and payment to: **State of Tennessee, Department of Environment and Conservation, Division of Fiscal Services - Fee Section, Davy Crockett Tower 7th Floor, 500 James Robertson Parkway, Nashville, TN 37243.**

**Required Documentation:** All applicants are required to provide **(1)** Valid employment status and identification documents (refer to page 4 "LISTS OF ACCEPTABLE DOCUMENTS" for required identification and employment status documents); **(2)** A copy of a current initial course completion certificate(s) **OR** a copy of a current refresher course completion certificate(s) and the previous training course completion certificate(s) in the appropriate disciplines (refer to page 3 "INSTRUCTION SHEET" for the complete training certificate requirements); **(3)** Valid documentation (diploma, certificate, or the equivalent) of education and/or work experience (refer to page 3 "INSTRUCTION SHEET" for the requirements for each discipline); and **(4)** A 2" x 2" passport-quality color photo.

**Application Fee Non-Refundable:** Applicants will have 30 days from the date of initial receipt of the application to submit any missing information and/or needed documentation to complete the application process. If an applicant fails to respond within 30 days, the application will be cancelled, and the applicant will be required to reapply.

**1 - APPLICANT INFORMATION**

FIRST NAME		MIDDLE INITIAL	LAST NAME		JR. SR. etc
AREA CODE / PHONE NUMBER 1	AREA CODE / PHONE NUMBER 2	AREA CODE / FAX NUMBER	E-MAIL ADDRESS		
STREET / MAILING ADDRESS		CITY	STATE	ZIP	

**2 - DISCIPLINE(S) AND FEE(S)**

A. <input type="checkbox"/> INSPECTOR	B. <input type="checkbox"/> RISK ASSESSOR	C. <input type="checkbox"/> SUPERVISOR	D. <input type="checkbox"/> PROJ DESIGNER	E. <input type="checkbox"/> WORKER
INITIAL <input type="checkbox"/> \$200 APP <input type="checkbox"/> \$70 EXAM	INITIAL <input type="checkbox"/> \$250 APP <input type="checkbox"/> \$70 EXAM	INITIAL <input type="checkbox"/> \$200 APP <input type="checkbox"/> \$70 EXAM	INITIAL <input type="checkbox"/> \$300 APP	INITIAL <input type="checkbox"/> \$60 APP
RECERT <input type="checkbox"/> \$200	RECERT <input type="checkbox"/> \$250	RECERT <input type="checkbox"/> \$200	RECERT <input type="checkbox"/> \$300	RECERT <input type="checkbox"/> \$60
ANNUAL <input type="checkbox"/> \$100	ANNUAL <input type="checkbox"/> \$125	ANNUAL <input type="checkbox"/> \$100	ANNUAL <input type="checkbox"/> \$150	ANNUAL <input type="checkbox"/> \$30
3 YEAR <input type="checkbox"/> \$400	3 YEAR <input type="checkbox"/> \$500	3 YEAR <input type="checkbox"/> \$400	3 YEAR <input type="checkbox"/> \$600	3 YEAR <input type="checkbox"/> \$120

TOTAL A \$ \_\_\_\_\_ TOTAL B \$ \_\_\_\_\_ TOTAL C \$ \_\_\_\_\_ TOTAL D \$ \_\_\_\_\_ TOTAL E \$ \_\_\_\_\_

TOTAL AMOUNT ENCLOSED ADD A THROUGH E ► \$ \_\_\_\_\_

**3 - EMPLOYMENT STATUS AND IDENTIFICATION DOCUMENTS**

U.S. CITIZEN  QUALIFIED ALIEN LAWFULLY PRESENT IN THE U.S.

Refer to Page 4 "LISTS OF ACCEPTABLE DOCUMENTS"- Choose one document from List A **OR** one document from List B **and** one document from List C. Check below which documents you have attached. All documents must be unexpired.

<b>List A</b>			<b>OR</b>	<b>List B</b>						<b>&lt; AND &gt;</b>		<b>List C</b>			
<input type="checkbox"/> 1	<input type="checkbox"/> 2	<input type="checkbox"/> 3		<input type="checkbox"/> 1	<input type="checkbox"/> 2	<input type="checkbox"/> 3	<input type="checkbox"/> 4	<input type="checkbox"/> 5	<input type="checkbox"/> 6	<input type="checkbox"/> 1	<input type="checkbox"/> 2	<input type="checkbox"/> 3	<input type="checkbox"/> 4		
<input type="checkbox"/> 4	<input type="checkbox"/> 5	<input type="checkbox"/> 6		<input type="checkbox"/> 7	<input type="checkbox"/> 8	<input type="checkbox"/> 9	<input type="checkbox"/> 10	<input type="checkbox"/> 11	<input type="checkbox"/> 12	<input type="checkbox"/> 5	<input type="checkbox"/> 6	<input type="checkbox"/> 7	<input type="checkbox"/> 8		

FD112815

4 - APPLICANT IDENTIFICATION INFORMATION (CONTINUED)										
FIRST NAME			MIDDLE INITIAL		LAST NAME			JR. SR. etc		
SOCIAL SECURITY NUMBER			DATE OF BIRTH		DRIVER LICENSE NUMBER		STATE	GENDER	HEIGHT	WEIGHT
XXX XX XXXX - -			MM DD YYYY / /					<input type="checkbox"/> MALE <input type="checkbox"/> FEMALE	FEET INCHES	POUNDS
5 - EDUCATION / PROFESSIONAL DEGREES, DIPLOMAS, AND CERTIFICATES (attach supporting documentation when required)										
HIGHEST LEVEL COMPLETED		<input type="checkbox"/> HIGH SCHOOL DIPLOMA	<input type="checkbox"/> GED	<input type="checkbox"/> TECHNICAL	COLLEGE DEGREE		<input type="checkbox"/> 2 YR	<input type="checkbox"/> 4 YR	<input type="checkbox"/> 4 YR +	
YEAR GRADUATED	SCHOOL NAME			STATE	DEGREE / CERTIFICATE	CERTIFICATE / REGISTRATION NUMBER		STATE ISSUED		
6 - EMPLOYMENT HISTORY (attach supporting documentation)										
FROM / TO	BUSINESS NAME - AREA CODE / PHONE NUMBER				DUTIES			SUPERVISOR		
7 - LEAD BASED PAINT TRAINING COURSE CERTIFICATE(S) (attach supporting documentation)										
DATE COMPLETED	NAME OF COURSE				TRAINING PROVIDER AND ADDRESS					
8 - ENVIRONMENTAL NON-COMPLIANCE ACTIONS (use additional paper if needed)										
HAVE YOU EVER RECEIVED A VIOLATION? IF YES, LIST VIOLATION(S)								STATE(S) OF OCCURRENCE		
9 - CERTIFICATION AND SIGNATURE										
<p>I certify, under penalty of law, that: I am lawfully present in the United States as a U.S. citizen or a qualified alien as defined in 8 U.S.C. §1641(b); this document and all attachments were prepared by me or under my direction or supervision; and, all of the submitted information is, to the best of my knowledge and belief, true, accurate, and complete. I understand that the penalties for providing false information and making false or fraudulent statements or representations may include revocation of the permit, license or accreditation, civil penalties, and/or criminal prosecution resulting in a fine, imprisonment or both. As specified in Tennessee Code Annotated Section 39-16-702(a)(4), this declaration is made under penalty of perjury. I affirm that the work practice standards according to Chapter Rule 0400-13-01 will be followed. I authorize the State of Tennessee to verify any information on or included with this application.</p>										
 _____ APPLICANT SIGNATURE					_____ DATE (mm / dd/ yyyy)					
_____ PRINTED NAME										
ALL APPLICANTS MUST SUBMIT: ▶										
<ol style="list-style-type: none"> <li>1. A COMPLETED AND SIGNED APPLICATION - IN INK</li> <li>2. VALID EMPLOYMENT STATUS AND IDENTIFICATION DOCUMENTS</li> <li>3. CURRENT COURSE COMPLETION CERTIFICATE(S)</li> <li>4. VALID DOCUMENTATION OF EDUCATION AND/OR WORK EXPERIENCE IF REQUIRED</li> <li>5. 2" x 2" PASSPORT-QUALITY COLOR PHOTOGRAPH</li> <li>6. APPROPRIATE FEES FOR EACH DISCIPLINE</li> </ol>										



State of Tennessee  
Department of Environment and Conservation  
Division of Solid Waste Management - Toxic Substances Program  
Davy Crockett Tower, 7th Floor  
500 James Robertson Parkway  
Nashville, TN 37243

**INSTRUCTIONS AND CLARIFICATION "APPLICATION TO CONDUCT LEAD-BASED PAINT ACTIVITIES - INDIVIDUAL" - FORM CN-1297**

For complete and detailed lead-based paint requirements, refer to Chapter Rule 0400-13-01. A copy is available for public download at:

**REQUIRED FOR ALL APPLICANTS:**

- 1) Complete and submit the application. Complete **all** sections of the application - in ink;
- 2) Include legible copies of valid employment status and identification documents (Refer to "LISTS OF ACCEPTABLE DOCUMENTS");
- 3) Current lead-based paint training course completion certificate(s) in the applied for discipline(s);  
**First-time applicant:** An initial course completion certificate from a Commissioner accredited training program; **or** a refresher course certificate from a Commissioner accredited training program **and** a copy of a refresher course certificate(s) from a Commissioner recognized training program from the previous year. An individual shall pass the Commissioner's third party certification exam for all disciplines, except project designer and abatement worker, and receive certification from the Commissioner within six months after completing an initial lead-based paint training course. Otherwise, the individual must retake the appropriate initial training course from an accredited training program before reapplying for certification from the Commissioner.  
**Re-accreditation Applicant:** Refresher course completion certificate(s) from a Commissioner accredited training program in the applied for discipline(s);
- 4) Include valid documentation of education and or work experience (Refer below to "INDIVIDUAL DISCIPLINE REQUIREMENTS")
- 5) Include a 2" x 2" passport-quality color photo;
- 6) Appropriate fees for each discipline.

**ANNUAL REGISTRATION RENEWAL OF CERTIFICATION:**

- 1) Individuals shall apply for annual registration renewal of their certification at least sixty days prior to their annual registration expiration date, which is one year from the last day of the month of issuance;
- 2) The annual registration renewal fee for each discipline shall be included with the application;
- 3) Annual registration renewal is required for all certification(s) categories that have not paid their three year certification fee(s).

**INDIVIDUAL DISCIPLINE REQUIREMENTS:** (attach documentation to application)

LEAD BASED PAINT CERTIFICATIONS ARE VALID FOR THREE YEARS

- ▶ **INSPECTOR:** Successful completion of an accredited training course for inspectors; Pass the third party certification exam for inspectors. No additional experience and/or education requirements for this discipline. Fill in all education and work experience fields on the application.
- ▶ **RISK ASSESSOR:** Successful completion of an accredited training course for inspectors and risk assessors; Pass the third party certification exam for the inspectors and risk assessors **and** have a Bachelor's degree with one year of experience in a related field (e.g. lead, asbestos, or environmental remediation work or construction); **or** an associate degree and two years experience in a related field (e.g. lead, asbestos, or environmental remediation work or construction); **or** currently hold credentials as a registered architect, certified industrial hygienist, professional engineer, registered architect, and/or certification in a related engineering/health/environmental field (e.g. safety professional, environmental scientist); **or** a high school diploma (or equivalent), and three years experience in a related field (e.g. lead, asbestos, or environmental remediation work or construction). **Re-accreditation applicants** must provide a valid Risk Assessor **and** Inspector refresher course completion certificate from a Commissioner accredited training program.
- ▶ **SUPERVISORS:** Successful completion of an accredited training course for supervisors; Pass the third party certification exam for supervisors. Have one year of experience as a certified lead-based paint abatement worker; or two years of experience in a related field (e.g., lead, asbestos, or environmental remediation work) or building construction).
- ▶ **PROJECT DESIGNERS:** Successful completion of an accredited training course for supervisors and project designers; Pass the third party certification exam for supervisors. Have a Bachelor's degree in engineering, architecture or a related profession **and** one year of experience in building construction and design or a related field; **or** four years of experience in building construction and design or a related field. **Re-accreditation applicants** must provide a valid Project Designer **and** Supervisor refresher course completion certificate from a Commissioner accredited training program.
- ▶ **ABATEMENT WORKER:** Successful completion of an accredited training course for worker. No additional experience and/or education requirements for this discipline. Fill in all education and work experience fields on the application.

**IMPORTANT INFORMATION:**

- Application fees are non-refundable. Applicants will have 30 days from the date of initial receipt of the application to submit any missing information and/or required documentation to complete the application process. If the applicant fails to respond within 30 days the application will be canceled.
- When an applicant receives their Tennessee lead-based paint credentials and identification card, the application process is complete pursuant to Rule 0400-13-01. Individuals may conduct lead based paint activities in Tennessee under the discipline(s) they have received accreditation for only when they receive their Tennessee lead-based paint credentials and identification card.
- Accredited individuals are required to have their Tennessee lead based paint accreditation card with them at the work site.
- Individuals should be aware that training requirements under OSHA regulations may differ.



**EMPLOYMENT STATUS AND IDENTIFICATION DOCUMENTATION**

**LISTS OF ACCEPTABLE DOCUMENTS**

Choose one document from List A, **or** choose one document from List B **and** one document from List C. All documents must be unexpired. Photocopied document(s) must be clear and legible. Attach photocopied document(s) to the application and check appropriate boxes in section 3 of the application - Form CN-1297 (Rev. 12-15)

LIST A	<b>OR</b>	LIST B	<b>&lt; AND &gt;</b>	LIST C
<b>1.</b> U.S. PASSPORT OR U.S. PASSPORT CARD		<b>1.</b> DRIVER'S LICENSE OR ID CARD ISSUED BY A STATE OR OUTLYING POSSESSION OF THE UNITED STATES PROVIDED IT CONTAINS A PHOTOGRAPH OR INFORMATION SUCH AS NAME, DATE OF BIRTH, GENDER, HEIGHT, EYE COLOR, AND ADDRESS		<b>1.</b> SOCIAL SECURITY ACCOUNT NUMBER CARD, UNLESS THE CARD INCLUDES ONE OF THE FOLLOWING RESTRICTIONS:  a. NOT VALID FOR EMPLOYMENT b. VALID FOR WORK ONLY WITH INS AUTHORIZATION c. VALID FOR WORK ONLY WITH DHS AUTHORIZATION
<b>2.</b> PERMANENT RESIDENT CARD OR ALIEN REGISTRATION RECEIPT CARD (FORM I-551)		<b>2.</b> ID CARD ISSUED BY FEDERAL STATE OR LOCAL GOVERNMENT AGENCIES OR ENTITIES, PROVIDED IT CONTAINS A PHOTOGRAPH OR INFORMATION SUCH AS NAME, DATE OF BIRTH, GENDER, HEIGHT, EYE COLOR AND ADDRESS		<b>2.</b> CERTIFICATION OF BIRTH ABROAD ISSUED BY THE DEPARTMENT OF STATE (FORM FS-545)
<b>3.</b> FOREIGN PASSPORT THAT CONTAINS A TEMPORARY I-551 STAMP OR TEMPORARY I-551 PRINTED NOTATION ON A MACHINE READABLE IMMIGRANT VISA		<b>3.</b> SCHOOL ID CARD WITH A PHOTOGRAPH		<b>3.</b> CERTIFICATION OF REPORT OF BIRTH ISSUED BY THE DEPARTMENT OF STATE (FORM DS-1350)
<b>4.</b> EMPLOYMENT AUTHORIZATION DOCUMENT THAT CONTAINS A PHOTOGRAPH (FORM I-766)		<b>4.</b> VOTER'S REGISTRATION CARD		<b>4.</b> ORIGINAL OR CERTIFIED COPY OF BIRTH CERTIFICATE ISSUED BY A STATE, COUNTY, MUNICIPAL AUTHORITY OR TERRITORY OF THE UNITED STATES BEARING AN OFFICIAL SEAL
<b>5.</b> FOR A NONIMMIGRANT ALIEN AUTHORIZED TO WORK FOR A SPECIFIC EMPLOYER BECAUSE OF HIS OR HER STATUS  a. A FOREIGN PASSPORT; AND  b. FORM I-94 OR FORM I-94A THAT HAS THE FOLLOWING:  (1) THE SAME NAME AS THE PASSPORT; AND  (2) AN ENDORSEMENT OF THE ALIEN'S NONIMMIGRANT STATUS AS LONG AS THAT PERIOD OF ENDORSEMENT HAS NOT YET EXPIRED AND THE PROPOSED EMPLOYMENT IS NOT IN CONFLICT WITH ANY RESTRICTIONS OR LIMITATIONS IDENTIFIED ON THE FORM		<b>5.</b> U.S. MILITARY CARD OR DRAFT RECORD		<b>5.</b> NATIVE AMERICAN TRIBAL DOCUMENT
		<b>6.</b> U.S. MILITARY DEPENDENT'S ID CARD		<b>6.</b> U.S. CITIZEN CARD (FORM I-197)
		<b>7.</b> U.S. COAST GUARD MERCHANT MARINER CARD		<b>7.</b> IDENTIFICATION CARD FOR USE OF RESIDENT CITIZEN IN THE UNITED STATES (FORM I-179)
		<b>8.</b> NATIVE AMERICAN TRIBAL DOCUMENT		<b>8.</b> EMPLOYMENT AUTHORIZATION DOCUMENT ISSUED BY THE DEPARTMENT OF HOMELAND SECURITY
<b>6.</b> PASSPORT FROM THE FEDERATED STATES OF MICRONESIA (FSM) OR THE REPUBLIC OF THE MARSHALL ISLANDS (RMI) WITH FORM I-94 OR FORM I-94A INDICATING NONIMMIGRANT ADMISSION UNDER THE COMPACT OF FREE ASSOCIATION BETWEEN THE UNITED STATES AND THE FSM OR RMI.		<b>9.</b> DRIVER'S LICENSE ISSUED BY A CANADIAN GOVERNMENT AUTHORITY		
		<b>FOR PERSONS UNDER 18 WHO ARE UNABLE TO PRESENT A DOCUMENT LISTED ABOVE</b>		
		<b>10.</b> SCHOOL RECORD OR REPORT CARD		
		<b>11.</b> CLINIC, DOCTOR, OR HOSPITAL RECORD		
		<b>12.</b> DAY-CARE OR NURSERY SCHOOL RECORD		
		<b>DO NOT RETURN THIS SHEET</b>		

FD120715

# **SECTION 3**

## **RULES OF DEPARTMENT OF ENVIRONMENT AND CONSERVATION DIVISION OF SOLID WASTE MANAGEMENT**

CHAPTER 0400-13-01

LEAD-BASED PAINT ABATEMENT

**RULES  
OF  
DEPARTMENT OF ENVIRONMENT AND CONSERVATION  
DIVISION OF SOLID WASTE MANAGEMENT**

**CHAPTER 0400-13-01**

**LEAD-BASED PAINT ABATEMENT**

Rule 0400-13-01-.01 Lead-Based Paint Abatement.

Rule 0400-13-01-.02 Lead-Based Paint Hazards

Rule 0400-13-01-.03 Residential Property Renovation

## **Subject: Updated Lead-Based Paint Rules and Regulations**

**To access the amended new state lead-based paint Rule on the Tennessee Secretary of State's website, click the link below. Once on that page of Rules of the Tennessee Department of Environment and Conservation, click, Chapter 0400-13-01.**

***[Secretary of State Official Published rule.](#)***

[Rule Chapter 0400-13-01-Lead-Based Paint Abatement](#) is effective June 5, 2024. It replaces and amends [Chapter 1200-01-18](#), which was effective September 26, 2000. Rule Chapter 0400-13-01-Lead-Based Paint Abatement implements Tennessee Code Annotated (T.C.A.) Section 68-131-401 et seq., Part 4-Tennessee Lead-Based Paint Abatement Certification Act of 1997. The State of Tennessee Lead Hazard Program became an EPA authorized program on January 17, 2001.

The Rule outlines procedures and requirements for accrediting training programs, certifying professionals, and establishing work practice standards for conducting lead-based paint abatement activities. The purpose is to ensure that individuals are properly trained and certified to conduct lead-based paint (LBP) activities in target housing and child-occupied facilities. Training programs are accredited to ensure that training curriculums adhere to specific requirements for each LBP discipline. The amended rule removes annual renewal of certification fees for firms and individuals and requires each to obtain a three-year certification. The amended rule allows training programs to offer online refresher training courses, if appropriately accredited and with limitations. It lowers the concentrations of dust-lead hazards and clearance levels, which are both congruent with current federal standards. It also establishes new fees for certification of individuals and firms, lead hazard reduction project notifications, accreditation of training programs. Penalties for non-compliance are also described.

**Department of State**  
**Division of Publications**  
 312 Rosa L. Parks Ave., 8th Floor, Snodgrass/TN Tower  
 Nashville, TN 37243  
 Phone: 615-741-2650  
 Email: [publications.information@tn.gov](mailto:publications.information@tn.gov)

**For Department of State Use Only**

Sequence Number: 03-07-24  
 Rule ID(s): 10058-10059  
 File Date: 3/7/2024  
 Effective Date: 6/5/2024

# Rulemaking Hearing Rule(s) Filing Form

Rulemaking Hearing Rules are rules filed after and as a result of a rulemaking hearing (Tenn. Code Ann. § 4-5-205).

Pursuant to Tenn. Code Ann. § 4-5-229, any new fee or fee increase promulgated by state agency rule shall take effect on July 1, following the expiration of the ninety (90) day period as provided in § 4-5-207. This section shall not apply to rules that implement new fees or fee increases that are promulgated as emergency rules pursuant to § 4-5-208(a) and to subsequent rules that make permanent such emergency rules, as amended during the rulemaking process. In addition, this section shall not apply to state agencies that did not, during the preceding two (2) fiscal years, collect fees in an amount sufficient to pay the cost of operating the board, commission, or entity in accordance with § 4-29-121(b).

<b>Agency/Board/Commission:</b>	Environment and Conservation
<b>Division:</b>	Solid Waste Management
<b>Contact Person:</b>	Adrienne White
<b>Address:</b>	William R. Snodgrass TN Tower 312 Rosa L. Parks Avenue, 14th Floor Nashville, Tennessee
<b>Zip:</b>	37243
<b>Phone:</b>	(615) 532-0885
<b>Email:</b>	<a href="mailto:Adrienne.White@tn.gov">Adrienne.White@tn.gov</a>

**Revision Type (check all that apply):**

- Amendment  Content based on previous emergency rule filed on \_\_\_\_\_  
 New  Content is identical to the emergency rule  
 Repeal

**Rule(s)** (ALL chapters and rules contained in filing must be listed here. If needed, copy and paste additional tables to accommodate multiple chapters. Please make sure that ALL new rule and repealed rule numbers are listed in the chart below. Please enter only ONE Rule Number/Rule Title per row.)

Chapter Number	Chapter Title
0400-13-01	Lead-Based Paint Abatement
Rule Number	Rule Title
0400-13-01-.01	Lead-Based Paint Abatement
0400-13-01-.02	Lead-Based Paint Hazards
0400-13-01-.03	Residential Property Renovation

Chapter Number	Chapter Title
1200-01-18	Lead-Based Paint Abatement
Rule Number	Rule Title
1200-01-18-.01	Lead-Based Paint Abatement
1200-01-18-.02	Reserved
1200-01-18-.03	Reserved
1200-01-18-.04	Reserved
1200-01-18-.05	Lead-Based Paint Hazards (Subpart D)
1200-01-18-.06	Residential Property Renovation (Subpart E)

Place substance of rules and other info here. Please be sure to include a detailed explanation of the changes being made to the listed rule(s). Statutory authority must be given for each rule change. For information on formatting rules go to <https://sos.tn.gov/products/division-publications/rulemaking-guidelines>.

Chapter 1200-01-18  
Lead-Based Paint Abatement

Repeal

Chapter 1200-01-18 Lead-Based Paint Abatement is repealed.

Authority: T.C.A. §§ 11-1-101, 68-131-401 et seq., and 4-5-201 et seq.

Chapter 0400-13-01  
Lead-Based Paint Abatement

New Rules

Table of Contents

0400-13-01-.01 Lead-Based Paint Abatement  
0400-13-01-.02 Lead-Based Paint Hazards  
0400-13-01-.03 Residential Property Renovation

0400-13-01-.01 Lead-Based Paint Abatement

- (1) Scope and applicability.
  - (a) This rule contains procedures and requirements for the accreditation of lead-based paint activities training programs, procedures, and requirements for the certification of individuals and firms engaged in lead-based paint activities, and work practice standards for performing such activities.
  - (b) This rule applies to all individuals and firms who are engaged in lead-based paint activities in “target housing” and “child occupied facilities,” as defined in paragraph (3) of this rule, except persons who perform these activities within residential dwellings that they own, unless the residential dwelling is occupied by a person or persons other than the owner or the owner’s immediate family while these activities are being performed, or a child residing in the building has been identified as having an elevated blood lead level, as defined in paragraph (3) of this rule.
  - (c) Each department, agency, and instrumentality of the executive, legislative, and judicial branches of the federal government, and of the State of Tennessee having jurisdiction over any property or facility, or engaged in any activity resulting, or that may result, in a lead-based paint hazard, and each officer, agent, or employee thereof, shall be subject to, and comply with all federal, State, interstate, and local requirements, both substantive and procedural, including the requirements of this rule regarding lead-based paint, lead-based paint activities, and lead-based paint hazards.
  - (d) Nothing in this rule requires that the owner or occupant undertake any particular lead-based paint activity.
  - (e) Use of Number and Gender – As used in these rules:
    1. Words in the masculine gender also include the feminine and neuter genders; and
    2. Words in the singular include the plural; and
    3. Words in the plural include the singular.
  - (f) Rule Structure – These rules are organized, numbered, and referenced according to the following outline form:

- (1) paragraph
  - (a) subparagraph
    - 1. part
      - (i) subpart
        - (l) item
          - I. subitem
            - A. section
              - (A) subsection

- (2) No person shall perform or represent that such person is qualified to perform any lead-based paint activities without having received the appropriate certification from the Commissioner, unless such person is:
  - (a) An owner performing abatement upon that person’s own residential property;
  - (b) An employee of a property management company doing routine cleaning and repainting upon property managed by that company, where there is insignificant damage to, wear of, or corrosion of existing lead-containing paint or coating substances; or
  - (c) An owner routinely cleaning or repainting the owner’s property, where there is insignificant damage to, wear of, or corrosion of existing lead-containing paint or coating substances.

(3) Definitions.

When used in this chapter, the following terms have the meanings given below unless otherwise specified:

“Abatement” means any measures or set of measures designed to permanently eliminate lead-based paint hazards. “Abatement” includes but is not limited to:

- (a) The removal of paint and dust, the permanent enclosure or encapsulation of lead-based paint, the replacement of painted surfaces or fixtures, or the removal or permanent covering of soil, when lead-based paint hazards are present in such paint, dust, or soil; and
- (b) All preparation, clean-up, disposal, and post-abatement clearance testing activities associated with such measures.
- (c) Specifically, abatement includes, but is not limited to:
  - 1. Projects for which there is a written contract or other documentation that provides that an individual or firm will be conducting activities in or to a residential dwelling or child-occupied facility that:
    - (i) Shall result in the permanent elimination of lead-based paint hazards; or
    - (ii) Are designed to permanently eliminate lead-based paint hazards and are described in subparagraphs (a) and (b) of this definition.
  - 2. Projects resulting in the permanent elimination of lead-based paint hazards, conducted by firms or individuals certified in accordance with paragraph (5) of this rule, unless such projects are covered by subparagraph (d) of this definition;
  - 3. Projects resulting in the permanent elimination of lead-based paint hazards, conducted by firms or individuals who, through their company name or promotional literature, represent, advertise, or hold themselves out to be in the business of performing lead-based paint

activities as identified and defined by this paragraph, unless such projects are covered by subparagraph (d) of this definition; or

4. Projects resulting in the permanent elimination of lead-based paint hazards, that are conducted in response to State or local government abatement orders.

- (d) Abatement does not include renovation, remodeling, landscaping, or other activities that are not designed to permanently eliminate lead-based paint hazards but are instead designed to repair, restore, or remodel a given structure or dwelling, even though these activities may incidentally result in a reduction or elimination of lead-based paint hazards. Furthermore, abatement does not include interim controls, operations and maintenance activities, or other measures and activities designed to temporarily, but not permanently, reduce lead-based paint hazards.

“Accessible surface” means an interior or exterior surface painted with lead-based paint that is accessible for ingestion by a child six years of age or younger.

“Accredited training program” means a training program that has been accredited by the Commissioner pursuant to paragraph (4) of this rule to provide training for individuals engaged in lead-based paint activities in the state of Tennessee.

“Adequate quality control” means a plan or design that ensures the authenticity, integrity, and accuracy of samples, including dust, soil, and paint chip or paint film samples. Adequate quality control also includes provisions for representative sampling pursuant to the requirements of subpart (6)(a)3(iii) of this rule.

“Arithmetic mean” means the algebraic sum of data values divided by the number of data values (e.g., the sum of the concentration of lead in several soil samples divided by the number of samples).

“Authorized state or Indian tribe” means a state or Indian tribe authorized by EPA pursuant to TSCA 15 U.S.C. § 2684 and 40 C.F.R. § 745.324 to administer the Lead-Based Paint Abatement Program in lieu of EPA.

“Available” means being present at a worksite during all abatement, cleaning, and clearance activities.

“Business day” means Monday through Friday with the exception of federal and state holidays.

“Certified abatement worker” means an individual who has been trained as a lead-based paint abatement worker by the EPA or any authorized state or Indian tribe accredited training program and is certified by the Commissioner to perform abatements.

“Certified firm” means a company, partnership, corporation, sole proprietorship, association, or other business entity that performs lead-based paint activities to which the Commissioner has issued a certificate of approval pursuant to subparagraph (5)(d) of this rule.

“Certified inspector” means an individual who has been trained as a lead-based paint inspector by the EPA or any authorized state or Indian tribe accredited training program and is certified by the Commissioner to conduct inspections. A certified inspector also samples for the presence of lead in dust and soil for the purposes of abatement clearance testing.

“Certified project designer” means an individual who has been trained as a lead-based paint project designer by the EPA or any authorized state or Indian tribe accredited training program and is certified by the Commissioner to prepare abatement project designs, occupant protection plans, and abatement reports.

“Certified risk assessor” means an individual who has been trained as a lead-based paint risk assessor by the EPA or any EPA authorized state or Indian tribe accredited training program and is certified by the Commissioner to conduct risk assessments. A risk assessor also samples for the presence of lead in dust and soil for the purposes of abatement clearance testing.

“Certified supervisor” means an individual who has been trained as a lead-based paint supervisor by the EPA or any EPA authorized state or Indian tribe accredited training program and is certified by the Commissioner to supervise and conduct abatements, and to prepare occupant protection plans and

abatement reports for a project of 10 or fewer units.

“Child-occupied facility” means a building or portion of a building constructed prior to 1978, visited regularly by the same child, six years of age or under, on at least two different days within any week (Sunday through Saturday period), provided that each day’s visit lasts at least three hours and the combined weekly visits last at least six hours, and the combined annual visits last at least 60 hours. Child-occupied facilities may include, but are not limited to, day-care centers, preschools, and kindergarten classrooms.

“Clearance levels” are values that indicate the amount of lead in dust on a surface following completion of an abatement activity. To achieve clearance when dust sampling is required, values below these levels must be achieved.

“Commissioner” means the Commissioner of the Department of Environment and Conservation or the Commissioner’s authorized representative.

“Common area” means a portion of a building that is generally accessible to all occupants. Such an area may include, but is not limited to, hallways, stairways, laundry and recreational rooms, playgrounds, community centers, garages, and boundary fences.

“Common area group” means a group of common areas that are similar in design, construction, and function. Common area groups include but are not limited to hallways, stairwells, and laundry rooms.

“Completion date” means the date on which all activities on a permitted lead-based paint abatement project requiring the use of certified individuals are complete, including but not limited to the complete disassembly of all removal area barriers, final clearance testing, and disposal of all lead-based paint waste.

“Component or building component” means specific design or structural elements or fixtures of a building, residential dwelling, or child-occupied facility that are distinguished from each other by form, function, and location. These include, but are not limited to, interior components such as: ceilings, crown molding, walls, chair rails, doors, door trim, floors, fireplaces, radiators and other heating units, shelves, shelf supports, stair treads, stair risers, stair stringers, newel posts, railing caps, balustrades, windows and trim (including sashes, window heads, jambs, sills, or stools and troughs), built-in cabinets, columns, beams, bathroom vanities, counter-tops, and air conditioners. These also include, but are not limited to, exterior components such as: painted roofing, chimneys, flashing, gutters, downspouts, ceilings, soffits, fascias, rake boards, corner boards, bulkheads, doors and door trim, fences, floors, joists, lattice work, railings and railing caps, siding, handrails, stair risers and treads, stair stringers, columns, balustrades, windowsills, or stools and troughs, casings, sashes and wells, and air conditioners.

“Concentration” means the relative content of a specific substance contained within a larger mass, such as the amount of lead (in micrograms per gram or parts per million by weight) in a sample of dust or soil.

“Containment” means a process to protect workers and the environment by controlling exposures to the lead-contaminated dust and debris created during an abatement.

“Course agenda” means an outline of the key topics to be covered during a training course, including the time allotted to teach each topic.

“Course test” means an evaluation of the overall effectiveness of the training that shall test the trainees’ knowledge and retention of the topics covered during the training course.

“Course test blueprint” means written documentation identifying the proportion of course test questions devoted to each major topic in the course curriculum.

“Deteriorated paint” means paint that is cracking, flaking, chipping, peeling, or otherwise separating from the substrate of a building component.

“Discipline” means one of the specific types or categories of lead-based paint activities identified in this rule for which individuals may receive training from accredited training programs and become certified by the Commissioner. For example, “abatement worker” is a discipline.

“Distinct painting history” means the application history, as indicated by its visual appearance or a record

of application, over time, of paint or other surface coatings to a component or room.

“Division” means the Department of Environment and Conservation, Division of Solid Waste Management.

“Documented methodologies” are state-of-the-art methods or protocols used to sample for the presence of lead in paint, dust, or soil.

“Drip line” means the area within three feet surrounding the perimeter of a building.

“Elevated blood lead level” or “EBLL” means an excessive absorption of lead that is a confirmed concentration of lead in whole blood of 20 ug/dl (micrograms of lead per deciliter of whole blood) for a single venous test or of 15-19 ug/dl in two consecutive tests taken three to four months apart.

“Encapsulant” means a substance that forms a barrier between lead-based paint and the environment using a liquid-applied coating (with or without reinforcement materials) or an adhesively-bonded covering material.

“Encapsulation” means the application of an encapsulant.

“Enclosure” means the use of rigid, durable construction materials that are mechanically fastened to the substrate to act as a barrier between lead-based paint and the environment.

“EPA” means the United States Environmental Protection Agency and its divisions and sections.

“Friction surface” means an interior or exterior surface that is subject to abrasion or friction, including but not limited to, certain window, floor, and stair surfaces.

“Guest instructor” means an individual designated by the training program manager or principal instructor to provide instruction specific to the lecture, hands-on activities, or work practice components of a course.

“Hands-on skills assessment” means an evaluation that tests the trainees’ ability to satisfactorily perform the work practices and procedures identified in subparagraph (4)(d) of this rule, as well as any other skill taught in a training course.

“Hazardous waste” means any waste as defined in subparagraph (1)(c) of Rule 0400-12-01-.02.

“Housing for the elderly” means retirement communities or similar types of housing reserved for households composed of one or more persons 62 years of age or more at the time of initial occupancy.

“Immediate family” means an individual’s family members, including parents, grandparents, children, grandchildren, or legal guardians.

“Impact surface” means an interior or exterior surface that is subject to damage by repeated sudden force such as certain parts of doorframes.

“Inspection” means a surface-by-surface investigation conducted by a lead-based paint inspector or risk assessor to determine the presence of lead-based paint and the provision of a report explaining the results of the investigation.

“Interim controls” means a set of measures designed to temporarily reduce human exposure or likely exposure to lead-based paint hazards, including but not limited to, specialized cleaning, repairs, maintenance, painting, temporary containment, ongoing monitoring of lead-based paint hazards or potential hazards, and the establishment and operation of management and resident education programs.

“Interior windowsill” means the portion of the horizontal window ledge that protrudes into the interior of the room.

“Last day of the month” means the last business day (Monday through Friday) of the calendar month, excluding state holidays.

“Lead-based paint” means paint or other surface coatings that contain lead equal to or exceeding 1.0

milligrams per square centimeter (mg/cm<sup>2</sup>), or more than 0.5 percent by weight.

“Lead-based paint abatement project” means the abatement of lead-based paint and lead-based paint hazards and submitted under a common project review notification.

“Lead-based paint activities” means, in the case of target housing and child-occupied facilities, inspection, risk assessment, lead-hazard screen, clearance testing, abatement, and lead-hazard reduction as defined in this rule. This does not include renovation, remodeling, landscaping, or other activities, when such activities are not designed to permanently eliminate lead-based paint hazards, but instead are designed to repair, restore, or remodel a structure, even though these activities may incidentally result in a reduction or elimination of lead-based paint hazards.

“Lead-based paint activities courses” or “training courses” means initial and refresher training courses (worker, supervisor, inspector, project designer, or risk assessor) provided by accredited training programs.

“Lead-based paint hazard” means any condition that causes exposure to lead from lead-contaminated dust, lead-contaminated soil, or lead-contaminated paint that is deteriorated or present in accessible surfaces, friction surfaces, or impact surfaces that would result in adverse human health effects as detailed in Rule 0400-13-01-.02.

“Lead-hazard reduction activities” means the inspection and assessment of lead-based paint hazards; the planning, implementation, and inspection of interim controls; and activities designed to reduce human exposure to lead-based paint hazards through both interim controls and abatement as determined by the Commissioner.

“Lead-hazard screen” is a limited risk assessment activity that involves limited paint and dust sampling as described in subparagraph (6)(c) of this rule.

“Living area” means any area of a residential dwelling used by one or more children aged six years and under, including but not limited to, living rooms, kitchen areas, dens, playrooms, and children’s bedrooms.

“Loading” means the quantity of a specific substance present per unit surface area such as the amount of lead in micrograms contained in the dust collected from a certain surface area divided by the surface area in square feet or square meters.

“Local government” means a county, city, town, borough, parish, district, association, or other public body (including an agency comprised of two or more of the foregoing entities) created under state law.

“Multi-family dwelling” means a structure that has more than one separate residential dwelling unit, which is used or occupied, or intended to be used or occupied, in whole or in part, as the home or residence of one or more persons.

“National certification exam” means an examination prepared by the EPA in a particular discipline that is administered by the Commissioner.

“Occupant” means any entity that has entered into an agreement as a lessee or purchaser of target housing, including but not limited to individuals, partnerships, corporations, trusts, government agencies, housing agencies, Indian tribes, and nonprofit organizations.

“Occupant protection plan” means a written plan, that describes the measure and management procedures that will be taken during abatement to protect building occupants from exposure to lead-based paint hazards. The plan shall be unique to each residential dwelling or child-occupied facility. For projects with 10 or fewer units, the plan shall be prepared by a lead supervisor or project designer. For projects with more than ten units, the plan shall be prepared by a lead project designer. The plan shall include the preparer’s signature and certification number.

“Owner” means any entity that has legal title to target housing, including but not limited to individuals, partnerships, corporations, trusts, government agencies, housing agencies, Indian tribes, and nonprofit organizations, except where a mortgagee holds legal title to property serving as collateral for a mortgage loan, in which case the owner would be the mortgagor.

“Paint in poor condition” means more than 10 square feet of deteriorated paint on exterior components with large surface areas; or more than two square feet of deteriorated paint on interior components with large surface areas (e.g., walls, ceilings, floors, doors); or more than 10% of the total surface area of the component is deteriorated on interior or exterior components with small surface areas (e.g., windowsills, baseboards, soffits, trim).

“Permanently covered soil,” means soil, that has been separated from human contact by the placement of a barrier consisting of solid, relatively impermeable materials such as pavement or concrete. Grass, mulch, and other landscaping materials are not considered permanent covering.

“Person” means an individual, trust, firm, joint stock company, corporation (including a government corporation), partnership, association, state, municipality, commission, political subdivision of a state, any interstate body, and governmental agency of this state, and any department, agency, or instrumentality of the executive, legislative, or judicial branches of the federal government.

“Play area” means an area of frequent soil contact by children six years of age or under as indicated by factors that include, but are not limited to: the presence of play equipment (e.g., sandboxes, swing sets, and sliding boards), toys, or other children’s possessions; observations of play patterns; or information provided by parents, residents, care givers, or property owners.

“Principal instructor” means the individual who has the primary responsibility for organizing and teaching a particular course.

“Project design” means a detailed description of the procedures, processes, and engineering controls that will be used to address the reduction of lead-based paint hazards, protect building occupants from lead exposure, and protect the environment from lead contamination.

“Project owner” means the person paying for the project.

“Reciprocity” means a cooperative interchange of privileges between consenting EPA authorized states or Indian tribes.

“Recognized laboratory” means an environmental laboratory recognized by EPA or the state pursuant to TSCA 15 U.S.C. § 2685(b) as being capable of performing an analysis for lead compounds in paint, soil, and dust.

“Reduction” means measures designed to reduce or eliminate human exposure to lead-based paint hazards through methods including interim controls and abatement.

“Renovation” means the modification of any existing structure, or portion thereof, that results in the disturbance of painted surfaces, unless that activity is performed as part of an abatement as defined in this paragraph. The term renovation includes (but is not limited to): the removal, modification, or repair of painted surfaces or painted components (e.g., modification of painted doors, surface restoration, window repair, surface preparation activity (such as sanding, scraping, or other such activities that may generate paint dust)); the removal of building components (e.g., walls, ceilings, plumbing, windows); weatherization projects (e.g., cutting holes in painted surfaces to install blown-in insulation or to gain access to attics, planning thresholds to install weather-stripping); and interim controls that disturb painted surfaces. A renovation performed for the purpose of converting a building, or part of a building, into target housing or a child-occupied facility is a renovation under this subpart. The term renovation does not include minor repair and maintenance activities as defined in paragraph (2) of Rule 0400-13-01-.03.

“Residential building” means a building containing one or more residential dwellings.

“Residential dwelling” means:

- (a) A detached single-family dwelling unit, including attached structures such as porches and stoops; or
- (b) A single-family dwelling unit in a structure that contains more than one separate residential dwelling unit, that is used or occupied, or intended to be used or occupied, in whole or in part, as the home or residence of one or more persons.

“Residential dwelling unit” means a single unit providing complete, independent living facilities for one or more persons including permanent provisions for living, sleeping, eating, cooking, and sanitation.

“Risk assessment” means an on-site investigation, conducted by a person certified by the Commissioner as a risk assessor, to determine and report the existence, nature, severity, and location of lead-based paint hazards in residential dwellings, including:

- (a) Information gathering regarding the age and history of the housing and occupancy by children under age six;
- (b) Visual inspection;
- (c) Limited wipe sampling or other environmental sampling techniques;
- (d) Other activity as may be appropriate; and
- (e) Provision of a report explaining the results of the investigation.

“Room” means a separate part of the inside of a building, such as a bedroom, living room, dining room, kitchen, bathroom, laundry room, or utility room. To be considered a separate room, the room must be separated from adjoining rooms by built-in walls or archways that extend at least six inches from an intersecting wall. Half walls or bookcases count as room separators if built in. Movable or collapsible partitions or partitions consisting solely of shelves or cabinets are not considered built-in walls. A screened in porch that is used as a living area is a room.

“Soil sample” means a sample collected in a representative location using ASTM E1727, "Standard Practice for Field Collection of Soil Samples for Lead Determination by Atomic Spectrometry Techniques," or equivalent method.

“Start date” means the first day of any lead-based paint activities training course or lead-based paint abatement activity.

“Start date provided to the Commissioner” means the date included in the original project review notification or the most recent start date provided to the Commissioner in an updated notification.

“State” means the State of Tennessee, Department of Environment and Conservation unless otherwise defined or indicated.

“Target housing” means any housing constructed prior to 1978, except housing for the elderly or persons with disabilities (unless any one or more children aged six years or under resides or is expected to reside in such housing for the elderly or persons with disabilities) or any zero-bedroom dwelling.

“Training curriculum” means an established set of course topics for instruction in an accredited training program for a particular discipline designed to provide specialized knowledge and skills.

“Training hour” means at least 50 minutes of actual learning, including, but not limited to, time devoted to lecture, learning activities, small group activities, demonstrations, evaluations, or hands-on experience.

“Training manager” means the individual responsible for administering a training program and monitoring the performance of principal instructors and guest instructors.

“Training program” or “training provider” means any person offering or seeking accreditation to offer lead-based paint activities courses under this rule.

“Train-the-trainer course” means instruction offered by an accredited or approved institution or school of higher learning that provides instructions on procedures, strategies, tools, and curriculum development for training adults.

“TSCA” means the Toxic Substances Control Act, 15 U.S.C. §§ 2601 to 2692.

“Visual inspection for clearance testing” means the visual examination of a residential dwelling or a child-occupied facility following an abatement to determine whether the abatement has been successfully completed.

“Visual inspection for risk assessment” means the visual examination of a residential dwelling or a child-occupied facility to determine the existence of deteriorated lead-based paint or other potential sources of lead-based paint hazards.

“Weighted arithmetic mean” means the arithmetic mean of sample results weighted by the number of subsamples in each sample. Its purpose is to give influence to a sample relative to the surface area it represents. A single surface sample is comprised of a single subsample. A composite sample may contain from two to four subsamples of the same area as each other and of each single surface sample in the composite. The weighted arithmetic mean is obtained by summing, for all samples, the product of the sample's result multiplied by the number of subsamples in the sample and dividing the sum by the total number of subsamples contained in all samples. For example, the weighted arithmetic mean of a single surface sample containing 60 µg/ft<sup>2</sup>, a composite sample (three subsamples) containing 100 µg/ft<sup>2</sup>, and a composite sample (4 subsamples) containing 110 µg/ft<sup>2</sup> is 100 µg/ft<sup>2</sup>. This result is based on the equation  $[60+(3*100)+(4*110)]/(1+3+4)$ .

“Window trough” means, for a typical double-hung window, the portion of the exterior windowsill between the interior windowsill (or stool) and the frame of the storm window. If there is no storm window, the window trough is the area that receives both the upper and lower window sashes when they are both lowered. The window trough is sometimes referred to as the window “well.”

“Zero-bedroom dwelling” means any residential dwelling in which the living area is not separated from the sleeping area. The term includes efficiencies, studio apartments, dormitory housing, military barracks, and rentals of individual rooms in residential dwellings.

(4) Accreditation of Training Programs, Classroom-based and Online Refresher Training Courses: Target Housing and Child-Occupied Facilities.

(a) Scope.

1. This rule contains procedures and requirements for the accreditation of lead-based paint activities training programs and lead-based paint courses and refresher training courses.
2. A training program may seek accreditation to offer lead-based paint activities courses and online refresher courses in any of the following disciplines: inspector, risk assessor, supervisor, project designer, or abatement worker. A training program may also seek accreditation to offer classroom-based and online refresher courses for each of the above listed disciplines.
3. No person shall provide, offer, or claim to provide a department-accredited lead-based paint activities course without first applying for and receiving accreditation from the Commissioner as required under subparagraph (b) of this paragraph.
4. Accredited training programs, training managers, and principal instructors must comply with all requirements of this paragraph including the terms of the application once approved by the Commissioner and all requirements and limitations specified in any accreditation documents issued to the training program by the Commissioner.

(b) Application process.

1. A training program seeking accreditation shall submit a written application to the Commissioner containing the following information:
  - (i) The training program's name, address (headquarters and training site), and telephone number;
  - (ii) A list of courses for which it is applying for accreditation. For the purposes of this paragraph, courses taught in different languages and online courses are

considered different courses, and each course must independently meet the accreditation requirements.

- (iii) The name and documentation of qualifications of the training manager;
- (iv) The name(s) and documentation of qualifications of any principal instructor(s);
- (v) A statement signed by the training manager certifying that the training program meets the requirements established in subparagraph (c) of this paragraph. If a training program uses EPA-recommended model training materials, or training materials approved by a state or Indian tribe that has been authorized by EPA, the training program manager shall also include a statement certifying that.
- (vi) If a training program does not use EPA-recommended model training materials or training materials approved by an authorized state or Indian tribe, its application for accreditation shall also include:
  - (I) A copy of the student and instructor manuals, or other materials to be used for each course;
  - (II) A copy of the course agenda for each course; and
  - (III) When applying for accreditation of a course in a language other than English, a signed statement from a qualified, independent translator that the independent translator has compared the course to the English language version and found the translation to be accurate.
- (vii) All training programs shall include in their application for accreditation the following:
  - (I) A description of the facilities and equipment to be used for lecture and hands-on training;
  - (II) A copy of the course test blueprint for each course;
  - (III) A description of the activities and procedures that will be used for conducting the assessment of hands-on skills for each course;
  - (IV) A copy of the quality control plan as described in part (c)9 of this paragraph;
  - (V) Identification of the person who developed or authored the course materials;
  - (VI) Starting times and ending times for each day of training, and the total hours of each course;
  - (VII) A list of learning objectives for each lecture, exercise, and hands-on activity; and
  - (VIII) Such other documentation as may be reasonably required by the Commissioner to determine whether an accreditation should be issued under this rule.

2. If a training program meets the requirements in subparagraph (c) of this paragraph, then the Commissioner shall approve or disapprove the application for accreditation no more than 180 days after receiving a complete application from the training program. In the case of approval, a certificate of accreditation shall be sent to the applicant. In the case of disapproval, a letter describing the reasons for disapproval shall be sent to the applicant. Prior to disapproval, the Commissioner may, at the Commissioner's discretion, work with the applicant to address inadequacies in the application for accreditation. The

Commissioner may also request additional materials retained by the training program under subparagraph (j) of this paragraph. If a training program's application is disapproved, the program may reapply for accreditation at any time by filing a new, complete application that includes the correct application fees.

3. A training program may apply for accreditation to offer courses or refresher courses in as many disciplines as it chooses. A training program may seek accreditation for additional courses at any time as long as the program can demonstrate that it meets the requirements of this paragraph.
4. A training program applying for accreditation must submit the appropriate application fees in accordance with paragraph (10) of this rule.

(c) Requirements for the accreditation of training programs.

For a training program to obtain accreditation from the Commissioner to offer or conduct lead-based paint activities courses, the program shall meet the following requirements:

1. The training program shall employ a training manager who has:
  - (i) At least two years of experience, education, or training in teaching workers or adults; or
  - (ii) A bachelor's or graduate degree in building construction technology, engineering, industrial hygiene, safety, public health, education, business administration or program management or a related field; or
  - (iii) Two years of experience in managing a training program specializing in environmental hazards; and
  - (iv) Demonstrated experience, education, or training in the construction industry including lead or asbestos abatement, painting, carpentry, renovation, remodeling, occupational safety and health, or industrial hygiene.
2. The training manager shall designate a qualified principal instructor for each training course who has:
  - (i) Demonstrated experience, education, or training in teaching workers or adults;
  - (ii) Successfully completed at least 16 hours of any EPA-accredited or EPA-authorized state or Tribal-accredited lead-specific training; and
  - (iii) Demonstrated experience, education, or training in lead or asbestos abatement, painting, carpentry, renovation, remodeling, occupational safety and health, or industrial hygiene.
3. The designated principal instructor shall be responsible for the organization of the training course and oversight of the teaching of all course material. The training manager may designate guest instructors as needed to provide instruction specific to the lecture, hands-on activities, or work practice components of a course. However, the principal instructor is primarily responsible for teaching the course materials and must be present to provide instruction (or oversight of portions of the training course taught by guest instructors) for the training course for which the individual has been designated the principal instructor.
4. The documents listed below may be required by the Commissioner to provide evidence that training managers and principal instructors have the education, work experience, training requirements, or demonstrated experience required by parts 1 and 2 of this subparagraph. This documentation shall be submitted with the accreditation application and shall be retained by the training program as required by subparagraph (j) of this paragraph.

- (i) Official academic transcripts or diploma as evidence of meeting the education requirements;
  - (ii) Resumes, letters of reference, and detailed descriptions of work experience, including the number of and dates of projects and jobs, the size of each project and job, descriptions of tasks performed by the individual, as evidence of meeting the work experience requirements; and the names and telephone numbers of supervisors; and
  - (iii) Certificates from train-the-trainer courses and lead-specific training courses, as evidence of meeting the training requirements.
5. The training program shall ensure the availability of, and provide adequate facilities for, the delivery of the lecture, course test, hands-on training, and assessment activities. This includes providing training equipment that reflects current work practices and maintaining or updating the equipment and facilities as needed.
6. To become accredited in the following disciplines, the training program shall provide training courses that meet the following training hour requirements:
- (i) The inspector course shall last a minimum of 24 training hours, with a minimum of eight hours devoted to hands-on training activities. The minimum curriculum requirements for the inspector course are contained in part (d)1 of this paragraph;
  - (ii) The risk assessor course shall last a minimum of 16 training hours, with a minimum of four hours devoted to hands-on training activities. The minimum curriculum requirements for the risk assessor course are contained in part (d)2 of this paragraph;
  - (iii) The supervisor course shall last a minimum of 32 training hours, with a minimum of eight hours devoted to hands-on activities. The minimum curriculum requirements for the supervisor course are contained in part (d)3 of this paragraph;
  - (iv) The project designer course shall last a minimum of eight training hours. The minimum curriculum requirements for the project designer course are contained in part (d)4 of this paragraph;
  - (v) The abatement worker course shall last a minimum of 16 training hours, with a minimum of eight hours devoted to hands-on training activities. The minimum curriculum requirements for the abatement worker course are contained in part (d)5 of this paragraph; and
  - (vi) Each training course shall require each student to participate in the minimum training hours, including the minimum hours devoted to hands-on training activities.
7. For each course offered, the training program shall conduct a course test at the completion of the course, and if applicable, a hands-on skills assessment. Each student must successfully complete the hands-on skills assessment and receive a passing score on the course test to pass any course.
- (i) The training manager is responsible for maintaining the validity and integrity of the hands-on skills assessment to ensure that it accurately evaluates the trainees' performance of the work practices and procedures associated with the course topics contained in subparagraph (d) of this paragraph.
  - (ii) The training manager is responsible for maintaining the validity and integrity of the course test to ensure that it accurately evaluates the trainees' knowledge and retention of the course topics.
  - (iii) The course test must be developed in accordance with the test blueprint submitted with the training accreditation application.

- (iv) Course tests must have a minimum of 25 questions for the worker test and 50 questions for other disciplines.
  - (v) To receive a passing score, an individual must correctly answer 70% or more of the course test questions.
8. The training program shall issue unique course completion certificates to each individual who passes the training course. The course completion certificate shall include:
- (i) The name, a unique identification number, and address of the individual;
  - (ii) The name of the particular course the individual completed (i.e., initial or refresher plus discipline);
  - (iii) Inclusive dates of the training course and the date of test passage;
  - (iv) The name, address, and telephone number of the training program;
  - (v) The street address of the training site if different from the training program's address;
  - (vi) The printed name and signature of the training manager;
  - (vii) The language in which the course was taught, if other than English;
  - (viii) The date the course was accredited and the name of the agency issuing the accreditation; and
  - (ix) For initial inspector, risk assessor, project designer, supervisor, or abatement worker course completion certificates, the expiration date of the training certificate.
9. The training manager shall develop and implement a quality control plan. The plan shall be used to maintain and improve the quality of the training program over time. This plan shall contain at least the following elements:
- (i) Procedures for periodic revision of training materials and the course test to reflect innovations in the field; and
  - (ii) Procedures for the training manager's annual review of principal instructor competency.
10. Training courses offered by the training program must teach the work practice standards contained in paragraph (6) of this rule, applicable to the lead-based paint activity being taught and other applicable standards developed by EPA or the Commissioner.
11. The training manager shall be responsible for ensuring that the training program complies at all times with all of the requirements in this paragraph.
12. The training manager shall allow the Commissioner to audit the training program to verify that the contents of the application for accreditation are as described in subparagraph (b) of this paragraph and to monitor compliance with the requirements outlined by this rule.
13. If a training program utilizes materials printed in a language other than English, the Commissioner shall be provided an accurate translation of the materials in English.
14. The training manager shall provide the Commissioner notification of the lead-based paint activities courses offered.
- (i) The original course notification must be received by the Commissioner at least seven business days prior to the start date of any lead-based paint activities course

offered.

- (ii) The training manager must provide the Commissioner updated notification when lead-based paint activities courses will begin on a date other than the start dates specified in the original course notification, as follows:
    - (I) For lead-based paint activities courses beginning prior to the start date provided to the Commissioner, an updated course notification must be received by the Commissioner at least seven business days before the new start date; and
    - (II) For lead-based paint activities courses beginning after the start date provided to the Commissioner, an updated course notification must be received by the Commissioner at least two business days before the start date provided to Commissioner.
  - (iii) The training manager must update the Commissioner of any change in location of lead-based paint activities courses at least seven business days prior to the start date provided to the Commissioner.
  - (iv) The training manager must update the Commissioner regarding any course cancellations or any other change to the original notification. Updated course notifications must be received by the Commissioner at least two business days prior to the start date provided to the Commissioner.
  - (v) Each course notification under this part, including updates, must include the following:
    - (I) Notification type (original, update, cancellation);
    - (II) Training program name, the accreditation number, address, and telephone number;
    - (III) Course discipline, type (initial/refresher), and the language in which instruction will be given;
    - (IV) Date(s) and time(s) of training;
    - (V) Training location(s), telephone number, and address;
    - (VI) Principal instructor's name; and
    - (VII) Training manager's name and signature.
  - (vi) Notification must be made by written or electronic notification by such means approved by the Commissioner. Written or electronic notification can be accomplished using the Division form titled "Lead-Based Paint Training Notification," or a successor form approved by the Commissioner.
  - (vii) Lead-based paint activities courses must not begin on a date, or at a location other than that specified in the original notification unless an updated notification identifying a new start date or location is submitted, in which case the course must begin on the new start date and/or location specified in the updated notification.
  - (viii) No training program shall provide lead-based paint activities courses without first notifying the Commissioner of such activities in accordance with the requirements of this part.
15. The training manager must provide notification following completion of lead-based paint activities courses.

- (i) The training manager must provide the Commissioner notification after the completion of any lead-based paint activities course. This notice must be received by the Commissioner no later than 10 business days following course completion.
- (ii) The notification must include the following:
  - (I) Training program name, accreditation number, address, and telephone number;
  - (II) Course discipline and type (initial/refresher);
  - (III) Date(s) of training;
  - (IV) The following information for each student who took the course:
    - I. Name;
    - II. Address;
    - III. Date of birth;
    - IV. Course completion certificate number;
    - V. Course test score;
    - VI. A digital photograph of the student; and
  - (V) Training manager's name and signature.
- (iii) Notification must be made by written or electronic notification by such means approved by the Commissioner. Written or electronic notification can be accomplished using the Division form titled "Lead-Based Paint Training Notification," or a successor form approved by the Commissioner.
- (d) Minimum training curriculum requirements.

A training program accredited by the Commissioner to offer lead-based paint courses in the specific disciplines listed in this subparagraph must ensure that its courses of study include, at a minimum, the following topics. Requirements ending in an asterisk (\*) indicate areas that require hands-on activities as an integral component of the course.

- 1. Inspector:
  - (i) Role and responsibilities of an inspector;
  - (ii) Background information on lead and its adverse health effects;
  - (iii) Background information on federal, State, and local regulations and guidance that pertains to lead-based paint and lead-based paint activities;
  - (iv) Lead-based paint inspection methods, including selection of rooms and components for sampling or testing; \*
  - (v) Paint, dust, and soil sampling methodologies; \*
  - (vi) Clearance standards and testing, including random sampling; \*
  - (vii) Preparation of the final inspection report; and \*
  - (viii) Recordkeeping.

2. Risk assessor:
  - (i) Role and responsibilities of a risk assessor;
  - (ii) Collection of background information to perform a risk assessment;
  - (iii) Sources of environmental lead contamination such as paint, surface dust and soil, water, air, packaging, and food;
  - (iv) Visual inspection for the purposes of identifying potential sources of lead-based paint hazards; \*
  - (v) Lead hazard screen protocol;
  - (vi) Sampling for other sources of lead exposure; \*
  - (vii) Interpretation of lead-based paint and other lead sampling results, including all applicable State or federal guidance or regulations pertaining to lead-based paint hazards; \*
  - (viii) Development of hazard control options, the role of interim controls, and operations and maintenance activities to reduce lead-based paint hazards; and \*
  - (ix) Preparation of a final risk assessment report.
3. Supervisor:
  - (i) Role and responsibilities of a supervisor;
  - (ii) Background information on lead and its adverse health effects;
  - (iii) Background information on federal, State, and local regulations and guidance that pertain to lead-based paint abatement;
  - (iv) Liability and insurance issues relating to lead-based paint abatement;
  - (v) Risk assessment and inspection report interpretation; \*
  - (vi) Development and implementation of an occupant protection plan and abatement report;
  - (vii) Lead-based paint hazard recognition and control; \*
  - (viii) Lead-based paint abatement and lead-based paint hazard reduction methods, including restricted practices; \*
  - (ix) Interior dust abatement and cleanup and lead-based paint hazard control and reduction methods; \*
  - (x) Soil and exterior dust abatement or lead-based paint hazard control and reduction methods; \*
  - (xi) Clearance standards and testing;
  - (xii) Cleanup and waste disposal; and
  - (xiii) Recordkeeping.
4. Project designer:
  - (i) Role and responsibilities of a project designer;

- (ii) Development and implementation of an occupant protection plan for large-scale abatement projects;
- (iii) Lead-based paint abatement and lead-based paint hazard reduction methods, including restricted practices for large-scale abatement projects;
- (iv) Interior dust abatement and cleanup and lead hazard control and reduction methods for large-scale abatement projects;
- (v) Clearance standards and testing for large-scale abatement projects; and
- (vi) Integration of lead-based paint abatement methods with modernization and rehabilitation projects for large-scale abatement projects.

5. Abatement worker:

- (i) Role and responsibilities of an abatement worker;
- (ii) Background information on lead and its adverse health effects;
- (iii) Background information on federal, state and local regulations and guidance that pertain to lead-based paint abatement;
- (iv) Lead-based paint hazard recognition and control; \*
- (v) Lead-based paint abatement and lead-based paint hazard reduction methods, including restricted practices; \*
- (vi) Interior dust abatement methods and cleanup and lead-based paint hazard reduction; and \*
- (vii) Soil and exterior dust abatement methods and lead-based paint hazard reduction.\*

(e) Requirements for the accreditation of refresher training courses.

A training program may seek accreditation to offer refresher training courses in any of the following disciplines: inspector, risk assessor, supervisor, project designer, and abatement worker. To obtain State accreditation to offer refresher training, a training program shall allow the Commissioner to audit the training program to verify the contents of the application for accreditation as described in subparagraph (b) of this paragraph. Any refresher training course offered by a training program shall also meet the following minimum requirements:

1. Each refresher course shall review the curriculum topics of the full-length courses listed under subparagraph (d) of this paragraph, as appropriate. In addition, to become accredited to offer refresher training courses, training programs shall ensure that their courses of study include, at a minimum, the following:
  - (i) An overview of current safety practices relating to lead-based paint activities in general, as well as specific information pertaining to the appropriate discipline;
  - (ii) Current laws and regulations relating to lead-based paint activities in general, as well as specific information pertaining to the appropriate discipline; and
  - (iii) Current technologies relating to lead-based paint activities in general, as well as specific information pertaining to the appropriate discipline.
2. Refresher courses for inspector, risk assessor, supervisor, and abatement worker shall last a minimum of eight training hours. The project designer refresher course shall last a minimum of four training hours. Refresher courses for all disciplines except project designer must include a hands-on component.

3. Except for project designer refresher courses, the training program shall conduct a hands-on skills assessment. All training programs shall conduct a course test with a minimum of 25 questions at the completion of the refresher course.
4. A training program may apply for accreditation of a refresher course concurrently with its application for accreditation of the corresponding training course as described in subparagraph (b) of this paragraph. If so, the Commissioner shall use the approval procedure described in subparagraph (b) of this paragraph. In addition, the minimum requirements contained in parts (c)1 through (c)5 of this paragraph and parts 1, 2, and 3 of this subparagraph shall also apply.
5. A training program seeking accreditation to offer refresher training courses shall submit a written application to the Commissioner containing the following information:
  - (i) The refresher training program's name, address, and telephone number, including the street address of the training site if different from the training program's address.
  - (ii) A list of refresher courses for which the refresher training program is applying for accreditation to offer.
  - (iii) The name and documentation of the qualifications of the training program manager.
  - (iv) The name(s) and documentation of the qualifications of the principal instructor(s).
  - (v) A statement signed by the training program manager certifying that the refresher training program meets the minimum requirements established in subparagraph (c) of this paragraph, except for the requirements in part (c)6 of this paragraph.
  - (vi) If a refresher training program uses EPA-developed model training materials, or training materials approved by a state or Indian tribe that has been authorized by EPA to develop its refresher training course materials, the training manager shall include a statement certifying that fact.
  - (vii) If the refresher training course materials are not based on EPA-developed model training materials or training materials approved by an authorized state or Indian tribe, the training program's application for accreditation shall include:
    - (I) A copy of the student and instructor manuals to be used for each course; and
    - (II) A copy of the course agenda for each course.
  - (viii) All refresher training programs shall include in their application for accreditation the following:
    - (I) A description of the facilities and equipment to be used for lecture and hands-on training;
    - (II) A copy of the course test blueprint for each course;
    - (III) A description of the activities and procedures that will be used for conducting the hands-on skills assessment for each course (if applicable); and
    - (IV) A copy of the quality control plan as described in part (c)9 of this paragraph.
  - (ix) The requirements in parts (c)1 through 5, and 7 through 15 of this paragraph apply

to refresher training providers.

- (x) If a refresher training program meets the requirements of this part, then the Commissioner shall approve or disapprove the application for accreditation no more than 180 days after receiving a complete application from the refresher training program. In the case of approval, a certificate of accreditation shall be sent to the applicant. In the case of disapproval, a letter describing the reasons for disapproval shall be sent to the applicant. Prior to disapproval, the Commissioner may, at the Commissioner's discretion, work with the applicant to address inadequacies in the application for accreditation. The Commissioner may also request additional materials retained by the refresher training program under subparagraph (j) of this paragraph. If a refresher training program's application is disapproved, the program may reapply for accreditation at any time.
  - (xi) The language in which the refresher training course is taught, if other than English.
  - (xii) The date the refresher course was accredited and the name of the agency issuing the accreditation.
- (f) Requirements for the accreditation of online asynchronous and synchronous refresher training courses.
1. This subparagraph outlines procedures and requirements for the accreditation of online lead-based paint refresher course or courses. Initial lead-based paint training courses may not be offered online.
  2. Only the following entities are authorized to offer online lead-based paint refresher courses:
    - (i) Training providers that are accredited by the State of Tennessee to conduct online refresher courses on the effective date of this rule, provided the course meets all the requirements of this rule;
    - (ii) Training providers that have been or are currently accredited by the State of Tennessee to conduct classroom-based lead-based training courses; and
    - (iii) Institutions of higher learning located in the State of Tennessee that have provided documentation of continuing education through online training courses.
  3. A pre-existing approval for a standard classroom-based refresher training course does not extend to cover an online refresher training course, even if the course is based upon the same syllabus or instructional materials.
  4. An online refresher course shall be specific to a discipline and shall be conducted as separate and distinct course and not combined with any other training during the period of the refresher course.
  5. A training provider may seek accreditation to offer, and approval of, online refresher lead-based paint training courses in any of the following disciplines: inspector, risk assessor, supervisor, project designer, and abatement worker.
  6. For the purposes of this subparagraph, online refresher courses taught in different languages, even if they are based on the same curriculum, are considered different courses, and each course must independently meet the accreditation and approval requirements and a separate fee must be paid for each such course.
  7. Online refresher training courses shall be the same length as a classroom-based refresher training course as set out in part (e)2 of this paragraph.
  8. To be accredited to provide and receive approval of an online refresher course, a training provider shall submit an application pursuant to subparagraph (b) of this paragraph, the appropriate fees, and documentation that the training provider meets each of the following

criteria:

- (i) Submits the instructor's credentials (including the credentials of those who conduct or develop the online refresher training course) and provides updates of any subsequent changes in course instructors;
- (ii) Has systems in place that authenticate the identity of the students taking the online refresher training course and the student's eligibility to enroll in the course. Student authentication could be obtained by the student submitting personal and sensitive information to a training provider such as social security number, date of birth, state lead-based paint certification number, and special question and answer combination. Verification of this authentication information shall be requested prior to beginning the online refresher training course and at intermittent, designated intervals during the training. A training provider shall use appropriate encryption technologies to protect the student's sensitive user information to deter fraud, including the falsification of student identity;
- (iii) Has systems in place that ensure students are focusing on the training material throughout the entire training period. Online refresher training courses shall provide a strong interactive component to ensure continued student focus, such as through threaded discussion between the student and the instructor and via interactive video clips;
- (iv) Has systems in place that prevent students from prematurely skipping ahead. A training provider shall make sure there are minimum time allotments for each section of the training, monitor and record the student's actual time online, including breaks, and retain these records;
- (v) Has a specific discipline course instructor available to answer questions that students have while they are taking the online refresher training course. This could be facilitated via online threaded discussion, message boards, chat, or a toll-free telephone number available during training periods for a student to call with questions for a specific discipline course instructor regarding the course material;
- (vi) Provides technical support via methods outlined in item (v) of this subpart to the student during training periods to address any technical problems that arise, such as with the student's computer or with the online application. If a student is inadvertently logged out of an online session due to technical difficulties, the student shall be given credit for the portion of the course already completed. Similarly, that student shall be required to make-up the portion of the training missed;
- (vii) Includes a comprehensive overview of the curriculum requirements contained in subparagraph (d) of this paragraph for the discipline covered;
- (viii) Verifies the identity of each student taking the examination for an online refresher course in some manner to prevent fraud. A training provider may have either a testing center or proctor-based exam for the examination portion of the online refresher training course. The examination questions shall be randomized from course to course so that the same examination is not given repeatedly. An item bank (or a pool of questions used to vary the questions asked) shall be used to ensure that examination questions are not used repeatedly. The training provider shall institute controls to ensure that the examination screen cannot be saved, copied, or printed;
- (ix) Includes a review and discussion of changes in federal, state, and local regulations that are applicable to Tennessee in each online refresher training course. A training provider shall clearly identify the state the online course is specifically applicable to and approved by when advertising the course or when registering a student for the course;

- (x) Ensures systems are in place that reduce opportunities for document fraud including a distinct, online training certificate that contains all the requirements of part (c)8 of this paragraph and that designates the course using the following language: Traditional Classroom, Asynchronous Online Course, or Synchronous Online Course; and
  - (xi) Provides a detailed description of how the hands-on component required by part (e)2 of this paragraph for an inspector, risk assessor, supervisor, and abatement worker will be accomplished and how the hands-on skills assessment will be given for each discipline.
9. A training provider shall provide, and retain in the provider's records, a course evaluation of the online course to help determine the strengths and weaknesses of such course and to promote continuous improvement.
  10. A training provider shall allow the Commissioner unrestricted access to conduct audits of an online course at any time that the course is being provided.
- (g) Re-accreditation of training programs.
1. Unless re-accredited, a training program's accreditation to offer a training course (including refresher training accreditation) shall expire two years after the date of issuance. If a training program meets the requirements of this paragraph, the training program shall be re-accredited.
  2. A training program seeking re-accreditation shall submit a complete application to the Commissioner no later than 45 days before its accreditation expires.
  3. The training program's application for re-accreditation shall contain:
    - (i) The training program's name, address, and telephone number;
    - (ii) A list of courses for which the training program is applying for re-accreditation;
    - (iii) The name and qualifications of the training program manager;
    - (iv) The name(s) and qualifications of the principal instructor(s);
    - (v) A description of any changes to the training facility, equipment or course materials since its last application was approved that adversely affects the students' ability to learn;
    - (vi) A statement signed by the program manager confirming:
      - (I) The training program complies at all times with all requirements of subparagraphs (c), (e), and (f) of this paragraph, as applicable; and
      - (II) The recordkeeping and reporting requirements of subparagraph (j) of this paragraph shall be followed.
    - (vii) A payment of appropriate fees in accordance with paragraph (10) of this rule.
  4. Upon request, the training program shall allow the Commissioner to audit the training program and any course provided by the training program, including an online refresher training course, to verify that the contents of the application for re-accreditation are as described in part 3 of this subparagraph. Upon the Commissioner anonymously auditing a training program by attending a training course, the training course fee paid by the State shall be refunded in its entirety to the Department of Environment and Conservation.
- (h) Refusal to review, suspension, revocation, and modification of accredited training programs.

1. The Commissioner may, after notice and an opportunity for hearing, refuse to renew, suspend, revoke, or modify training program accreditation, including refresher training accreditation, if a training program, training manager, or other person with supervisory authority over the training program has:
  - (i) Misrepresented the contents or training hour requirements of a training course to the State or the student population;
  - (ii) Failed to submit required information or notifications required under this rule in a timely manner;
  - (iii) Failed to maintain required records;
  - (iv) Falsified accreditation records, instructor qualifications, or other accreditation-related information or documentation;
  - (v) Failed to comply with the training standards and requirements in this chapter;
  - (vi) Failed to comply with federal, State, or local lead-based paint statutes or regulations;
  - (vii) Made false or misleading statements in its application for accreditation or re-accreditation;
  - (viii) An environmental compliance history that demonstrates an unwillingness or inability to maintain compliance with environmental statutes or regulations;
  - (ix) A duly authorized representative, training manager, or principal instructor who has been convicted of a felony or found liable in a civil proceeding that involves violation of any state or federal regulation or law designed to protect human health or the environment; or
  - (x) Failed to achieve and maintain active status as a business entity with the Tennessee Secretary of State if required.
2. In addition to an administrative or judicial finding of violation, execution of a consent agreement in settlement of an enforcement action constitutes, for purposes of this rule, evidence of a failure to comply with relevant statutes or regulations.
3. The Commissioner may deny any application for a training program accreditation, including refresher training accreditation, for any reason set out in part 1 of this subparagraph.

- (i) Procedures for refusal to renew, suspension, revocation, or modification of training program accreditation.

Any revocation, suspension, refusal to renew, modification, or denial of an application to renew a training program accreditation shall be conducted in accordance with the Uniform Administrative and Procedures Act, T.C.A. Title 4, Chapter 5, Part 3.

- (j) Training Program Recordkeeping Requirements.

1. Accredited training programs shall maintain and make available to the Commissioner, upon request, the following records:
  - (i) All documents specified in part (c)4 of this paragraph that demonstrate the qualifications listed in parts (c)1 and 2 of this paragraph of the training manager and principal instructors;
  - (ii) Current curriculum/course materials and documents reflecting any changes made to these materials;

- (iii) The course test blueprint;
  - (iv) Information regarding how the hands-on skills assessment is conducted including, but not limited to:
    - (I) Who conducts the assessment;
    - (II) How the skills are graded;
    - (III) What facilities are used; and
    - (IV) The pass/fail rate;
  - (v) The quality control plan as described in part (c)9 of this paragraph;
  - (vi) Results of the students' hands-on skills assessments and course tests and a record of each student's course completion certificate;
  - (vii) Any other material not listed above in subparts (i) through (vi) of this part that was submitted to the Commissioner as part of the program's application for accreditation; and
  - (viii) For training courses delivered in an electronic format, a record of each student's log-ins, launches, progress, and completion, and a copy of the online learning completion certificate for each student.
2. The training program shall retain these records at the address specified on the training program accreditation application (or as modified in accordance with part 3 of this subparagraph) for a minimum of three years and six months from course completion.
  3. The training program shall notify the Commissioner in writing within 30 days of changing the address specified on its training program accreditation application or transferring the records from that address.
- (k) Amendment of accreditation.
1. A training program must amend its accreditation within 90 days of the date a change occurs to information included in the program's most recent application. If the training program fails to amend its accreditation within 90 days of the date the change occurs, the program may not provide lead-based paint activities training until its accreditation is amended.
  2. To amend an accreditation, a training program must submit a completed "Accreditation Application for Training Providers," signed by an authorized agent of the training provider, noting on the form that it is submitted as an amendment and indicating the information that has changed.
  3. If the amendment includes a new training program manager, any new or additional principal instructor(s), or any new permanent training location(s), the training program is not permitted to provide training under the new training manager or offer courses taught by any new principal instructor(s) or at the new training location(s) until the Commissioner either approves the amendment or 30 days have elapsed since an amendment has been submitted to the Commissioner, whichever occurs earlier, except:
    - (i) If the amendment includes a new training program manager or a new or additional principal instructor who was identified in a training provider accreditation application that the Commissioner has already approved under this paragraph, the training program may begin to provide training under the new training manager or offer courses taught by the new principal instructor on an interim basis as soon as the provider submits the amendment to the Commissioner. The training program may continue to provide training under the new training manager or offer courses taught by the new principal instructor if the Commissioner approves the

amendment or if the Commissioner does not disapprove the amendment within 30 days.

- (ii) If the amendment includes a new permanent training location, the training program may begin to provide training at the new permanent training location on an interim basis as soon as the provider submits the amendment to the Commissioner. The training program may continue to provide training at the new permanent training location if the Commissioner approves the amendment or if the Commissioner does not disapprove the amendment within 30 days.

(5) Certification of Individuals and Firms Engaged in Lead-Based Paint Activities: Target Housing and Child-Occupied Facilities.

(a) Certification of Individuals.

1. Individuals seeking certification by the Commissioner to engage in lead-based paint activities must:
  - (i) Either:
    - (I) Submit to the Commissioner an application (on forms provided by the Division) demonstrating that they meet the requirements established in subparagraph (b) of this paragraph for the particular discipline(s) for which certification is sought along with the appropriate application fees in accordance with paragraph (10) of this rule; or
    - (II) Submit to the Commissioner an application (on forms provided by the Division) with a legible copy of a valid lead-based paint activities certification from EPA or an EPA-authorized state or Indian tribe along with the appropriate application fees in accordance with paragraph (10) of this rule. Completing the refresher training requirements in subparagraph (c) of this paragraph and passing the national certification exam may be required prior to certification based upon the Commissioner's evaluation of submitted documents;
  - (ii) Submit to the Commissioner a standard color passport photograph with each application for the lead-based paint activity discipline for which certification is sought, and
  - (iii) Submit an attestation and documentation complying with the requirements of the Eligibility Verification for Entitlements Act, codified at T.C.A. Title 4, Chapter 58, Part 1.
2. Following the submission of a complete application demonstrating, to the Commissioner's satisfaction, that all the requirements of this paragraph have been met, the Commissioner shall certify an applicant as an inspector, risk assessor, supervisor, project designer, abatement worker, or combination thereof, as applicable.
3. Upon receiving the Commissioner's certification, individuals conducting lead-based paint activities shall comply with the work practice standards for performing the appropriate lead-based paint activities established in paragraph (6) of this rule.
4. It shall be a violation of this rule for an individual to conduct any of the lead-based paint activities described in paragraph (6) of this rule if that individual has not been certified to do so by the Commissioner.
5. Unless the Commissioner revokes, suspends, or refuses to renew the certification of an individual engaged in lead-based paint activities, certification shall be valid for three years. The expiration date shall be three years from the last day of the calendar month of issuance.

(b) Inspector, Risk Assessor, Supervisor, Project Designer, or Abatement Worker.

1. To become certified by the Commissioner as an inspector, risk assessor, supervisor, project designer, or abatement worker, pursuant to subpart (a)1(i) of this paragraph, an individual must:
  - (i) Successfully complete an accredited course in the appropriate discipline, including passage of the course exam, and receive a course completion certificate from an EPA, or an EPA authorized state or Indian tribe accredited training program;
  - (ii) Except for the abatement worker, pass the national certification exam in the appropriate discipline offered by the Commissioner; and
  - (iii) Meet or exceed the following requirements:
    - (I) Inspectors: no additional experience or education requirements.
    - (II) Risk assessors:
      - I. Successful completion of an accredited training course for inspectors; and
      - II. Bachelor's degree and one year of experience in a related field (e.g., lead, asbestos, environmental remediation work, or construction), or an associate's degree and two years of experience in a related field (e.g., lead, asbestos, environmental remediation work, or construction); or
      - III. Certification as an industrial hygienist, professional engineer, registered architect, or certification in a related engineering/health/environmental field (e.g., safety professional, environmental scientist); or
      - IV. A high school diploma (or equivalent), and at least three years of experience in a related field (e.g., lead, asbestos, environmental remediation work or construction).
    - (III) Supervisors:
      - I. One year of experience as a certified lead-based paint abatement worker; or
      - II. At least two years of experience in a related field (e.g., lead, asbestos, or environmental remediation work) or in the building trades.
    - (IV) Project designers:
      - I. Successful completion of an accredited training course for supervisors;
      - II. Bachelor's degree in engineering, architecture, or a related profession, and one year of experience in building construction and design or a related field; or
      - III. Four years of experience in building construction and design or a related field.
    - (V) Abatement workers: no additional experience or education requirements.

2. Applicants for certification shall submit proof satisfactory to the Commissioner of meeting

the requirements of this subparagraph, including but not limited to the following documents:

- (i) Official academic transcripts or diploma, as evidence of meeting the education requirements;
- (ii) Resumes, letters of reference, or documentation of work experience, as evidence of meeting the work experience requirements; and
- (iii) Course completion certificates from lead-specific or other related training courses, issued by accredited training programs, as evidence of meeting the training requirements.

3. In order to take the national certification exam for a particular discipline, an individual must:

- (i) Successfully complete an accredited course in the appropriate discipline, which includes passing the course exam, and receive a course completion certificate from an accredited training program; and
- (ii) Meet or exceed the education and/or experience requirements in subpart 1(ii) of this subparagraph.

4. After passing the appropriate national certification exam and submitting an application demonstrating, to the Commissioner's satisfaction, that the individual meets all applicable training, education, and experience prerequisites established in part 1 of this subparagraph, the Division shall issue a photo identification certification card to the individual. To maintain certification, an individual must be re-certified as described in subparagraph (c) of this paragraph.

5. An individual may take the Commissioner's national certification exam no more than three times within six months of receiving a course completion certificate.

6. If an individual does not pass the certification exam and receive a certificate with six months of receiving the individual's course completion certificate, the individual must retake the appropriate course from an accredited training program before reapplying for certification from the state.

(c) Re-certification of individuals.

1. To maintain certification in a particular discipline, a certified individual shall apply to and be re-certified in that discipline by the Commissioner every three years.

2. To obtain re-certification, an individual previously certified by the Commissioner shall:

- (i) Successfully complete the appropriate accredited refresher training course or courses within one year prior to the expiration date of their current certification;
- (ii) Submit to the Commissioner a complete re-certification application with a legible copy of the lead-based paint refresher training course completion certificate at least 60 days prior to the expiration of certification;
- (iii) Submit to the Commissioner a standard color passport photograph with an application for each lead-based paint discipline for which re-certification is sought; and
- (iv) Submit the appropriate application fee in accordance with paragraph (10) of this rule.

3. A risk assessor must timely complete the refresher courses for both inspectors and risk assessors to be re-certified.

4. A project designer shall timely complete the refresher courses for both supervisors and

project designers to be re-certified.

(d) Certification of firms.

1. All firms that perform or offer to perform any of the lead-based paint activities described in paragraph (6) of this rule shall be certified by the Commissioner.
2. A firm seeking certification shall submit to the Commissioner an application on forms provided by the Division, the appropriate application fees in accordance with paragraph (10) of this rule, and a letter attesting that the firm will only employ appropriately certified employees to conduct lead-based paint activities and that the firm and its employees will follow the work practice standards in paragraph (6) of this rule for conducting lead-based paint activities. The application shall include, but not be limited to:
  - (i) The name of the firm;
  - (ii) The firm's federal employer identification number, if applicable;
  - (iii) If the firm is an individual, a general partnership, or other business entity where individuals hold the right to all or part of the certification, the names and Social Security Numbers of each individual or general partner;
  - (iv) Contact information for the firm, including the firm's phone number, fax number, email address, and mailing address;
  - (v) A list of any environmental non-compliance actions taken against the firm, the date of such actions, and the state where such actions occurred;
  - (vi) If the firm is an individual, general partnership, or other business entity where individuals hold the right to all or part of the certification, an attestation and documentation for each such individual complying with the requirements of the Eligibility Verification for Entitlements Acts, codified at T.C.A. Title 4, Chapter 58, Part 1; and
  - (vii) All other documentation as may be reasonably requested by the Commissioner to determine whether such application shall be granted or denied.
3. From the date of receiving the firm's complete application requesting certification, the Commissioner shall have 90 days to approve or disapprove the firm's request for certification. Within that time, the Commissioner shall respond with either a Certificate of Approval or a letter describing the reasons for disapproval.
4. The firm shall maintain all records pursuant to the requirements in paragraph (6) of this rule.
5. Firms applying for re-certification must submit the documents described in part 2 of this subparagraph and appropriate fees described in paragraph (10) of this rule.
6. Firms may first apply to the Commissioner for certification to engage in lead-based paint activities pursuant to this paragraph on or after the effective date of this rule.
7. Unless the Commissioner revokes or suspends the certification of a firm engaged in lead-based paint activities, certification shall be valid for three years. The certification expiration date shall be three years from the last day of the month of issuance.

(e) Violations for individuals.

1. It shall be a violation of this chapter for any individual to have:
  - (i) Obtained training documentation through fraudulent means;

- (ii) Gained admission to and completed an accredited training program through misrepresentation of qualifications for admission;
  - (iii) Obtained certification through misrepresentation of the individual's education, training, professional registration, or experience;
  - (iv) Performed work requiring certification at a job site without being in physical possession of a valid photo identification certification card;
  - (v) Permitted the duplication or use of the individual's certificate by another person;
  - (vi) Performed work for which certification is required, but for which the appropriate certification had not been received at that time;
  - (vii) Failed to comply with the appropriate work practice standards for lead-based paint activities in paragraph (6) of this rule;
  - (viii) Failed to comply with federal, State, or local lead-based paint statutes or regulations;
  - (ix) Been convicted of an environmental felony or found liable in a civil proceeding that involves violations of any state or federal regulation or law designed to protect human health or the environment; or
  - (x) An environmental history that demonstrates an unwillingness or inability to maintain compliance with environmental statutes or regulations.
2. In addition to an administrative or judicial finding of violation, for purposes of this chapter only, execution of a consent or settlement agreement in settlement of an enforcement action constitutes evidence of a failure to comply with relevant statutes or regulations.
- (f) Violations for firms.
1. It shall be a violation of this chapter for any firm to have:
- (i) Performed work requiring certification at a job site with individuals who are not certified;
  - (ii) Failed to comply with the work practice standards established in paragraph (6) of this rule;
  - (iii) Misrepresented facts in its letter of application for certification to the state;
  - (iv) Failed to maintain required records;
  - (v) Failed to comply with federal, State, or local lead-based paint statutes or regulations;
  - (vi) An environmental history that demonstrates an unwillingness or inability to maintain compliance with environmental statutes or regulations;
  - (vii) Been convicted of an environmental felony or found liable in a civil proceeding that involves violations of any state or federal regulation designated to protect human health or the environment; or
  - (viii) Failed to be actively registered, if required, as a business entity with the Tennessee Secretary of State as required by law.
2. In addition to an administrative or judicial finding of violation, for purposes of this chapter only, execution of a consent agreement in settlement of an enforcement action constitutes evidence of a failure to comply with relevant statutes or regulations.

3. The Commissioner may deny any application for the certification of an individual for any reason set out in subparagraph (e) of this paragraph. The Commissioner may deny any application for the certification of a firm for any reason set out in subparagraph (f) of this paragraph.

- (g) Procedures for suspension, revocation, or modification of the certification of individuals or firms.

Any revocation, suspension, or denial of an application to renew the certification of an individual or firm shall be conducted in accordance with the Uniform Administrative Procedures Act, T.C.A. Title 4, Chapter 5, Part 3.

- (h) Unless otherwise specified in writing by the Commissioner:

1. An individual whose certification in a discipline has been suspended must complete any required refresher training courses to renew the suspended accreditation.
2. An individual whose certification in a discipline has been revoked must take any required initial training courses and reapply to become certified again.
3. A firm whose certification has been revoked must reapply for certification after the revocation period ends to become certified again.
4. A firm whose certification has been suspended and the suspension ends prior to the expiration of the firm's certification is not required to do anything to re-activate its certification. However, if the firm's certification expires during the suspension period, the firm must reapply for certification after the suspension ends.

- (6) Work Practice Standards for Conducting Lead-Based Paint Activities: Target Housing and Child- Occupied Facilities.

- (a) Applicability and Terms.

1. All lead-based paint activities shall be performed pursuant to the work practice standards contained in this paragraph.
2. When performing any lead-based paint activity described by the certified individual as an inspection, lead-hazard screen, risk assessment, project design, or abatement, a certified individual must perform that activity in compliance with the appropriate requirements of this paragraph.
3. Documented methodologies that are appropriate for this paragraph are found in the following:
  - (i) The U.S. Department of Housing and Urban Development (HUD) Guidelines for the Evaluation and Control of Lead-Based Paint Hazards in Housing;
  - (ii) The EPA Guidance on Residential Lead-Based Paint, Lead-Contaminated Dust, and Lead-Contaminated Soil;
  - (iii) The EPA Residential Sampling for Lead: Protocols for Dust and Soil Sampling (EPA report number 7474-R-95-001);
  - (iv) Regulations, guidance, methods or protocols issued by states and Indian tribes that have been authorized by EPA;
  - (v) The Enterprise Foundation, Housing Developer Pro specification computer software package; and
  - (vi) Other equivalent methods and guidelines.

4. Clearance levels that are appropriate for the purposes of this paragraph may be found in subpart (f)9(viii) of this paragraph.
- (b) Inspection.
1. An inspection shall be conducted only by a person certified by the Commissioner as an inspector or risk assessor and, if conducted, must be conducted according to the procedures of this subparagraph.
  2. When conducting an inspection, the following locations shall be selected according to documented methodologies and tested for the presence of lead-based paint:
    - (i) In a residential dwelling and child-occupied facility, each component with a distinct painting history and each exterior component with a distinct painting history shall be tested for lead-based paint, except those components that the inspector or risk assessor determines to have been replaced after 1978 or to not contain lead-based paint; and
    - (ii) In a multi-family dwelling or child-occupied facility, each component with a distinct painting history in every common area, except those components that the inspector or risk assessor determines to have been replaced after 1978 or to not contain lead-based paint.
  3. Paint shall be sampled in the following manner:
    - (i) The analysis of paint to determine the presence of lead shall be conducted using documented methodologies that incorporate adequate quality control procedures; and
    - (ii) All collected paint chip samples shall be analyzed according to subparagraph (g) of this paragraph to determine if they contain detectable levels of lead that can be quantified numerically.
  4. The certified inspector or risk assessor shall prepare an inspection report and comply with the project review acknowledgement required in part (k)1 of this paragraph. The inspection report shall include the following information:
    - (i) Date of each inspection;
    - (ii) Address of building;
    - (iii) Date of construction;
    - (iv) Apartment numbers (if applicable);
    - (v) Name, address, and telephone number of the owner or owners of each residential dwelling or child-occupied facility;
    - (vi) Name, signature, and certification number of each certified inspector and risk assessor conducting testing;
    - (vii) Name, address, and telephone number of the certified firm employing each inspector and risk assessor, if applicable;
    - (viii) Each testing method and device and/or sampling procedure employed for paint analysis, including quality control data and, if used, the serial number of any x-ray fluorescence (XRF) device;
    - (ix) Specific locations of each painted component tested for the presence of lead-based paint; and

- (x) The results of the inspection expressed in terms appropriate to the sampling method used.
5. The inspection report required by part 4 of this subparagraph shall be made available to the Commissioner upon request.
- (c) Lead Hazard Screen.
- 1. A lead hazard screen shall be conducted only by a person certified by the Commissioner as a risk assessor.
  - 2. A lead hazard screen shall be conducted as follows:
    - (i) Background information regarding the physical characteristics of the residential dwelling or child-occupied facility and occupant use patterns that may cause lead-based paint exposure to one or more children age six years and under shall be collected.
    - (ii) A visual inspection of the residential dwelling or child-occupied facility shall be conducted to:
      - (I) Determine if any deteriorated paint is present, and
      - (II) Locate at least two dust sampling locations.
    - (iii) If deteriorated paint is present, each surface with deteriorated paint, that is determined, using documented methodologies, to be in poor condition and to have a distinct painting history, shall be tested for the presence of lead.
    - (iv) In residential dwellings, two composite dust samples shall be collected, one from the floors and the other from the windows, in rooms, hallways, or stairwells where one or more children, age six and under, are most likely to come in contact with dust.
    - (v) In multi-family dwellings and child-occupied facilities, in addition to the floor and window samples required in subpart (iv) of this part, the risk assessor shall also collect composite dust samples from common areas where one or more children, age six and under, are most likely to come into contact with dust.
  - 3. Dust samples shall be collected and analyzed in the following manner:
    - (i) All dust samples shall be taken using documented methodologies that incorporate adequate quality control procedures; and
    - (ii) All collected dust samples shall be analyzed according to subparagraph (g) of this paragraph to determine if they contain detectable levels of lead that can be quantified numerically.
  - 4. Paint shall be sampled in the following manner:
    - (i) The analysis of paint to determine the presence of lead shall be conducted using documented methodologies that incorporate adequate quality control procedures; and
    - (ii) All collected paint chip samples shall be analyzed according to subparagraph (g) of this paragraph to determine if they contain detectable levels of lead that can be quantified numerically.
  - 5. The risk assessor shall prepare a lead hazard screen report, which shall include the following information:

- (i) The information required in a risk assessment report as specified in subparagraph (d) of this paragraph, including subparts (d)11(i) through (xiv) of this paragraph, and excluding subparts (d)11(xv) through (xviii) of this paragraph. Additionally, any background information collected pursuant to subpart 2(i) of this subparagraph shall be included in the risk assessment report; and
  - (ii) Recommendations, if warranted, for a follow-up risk assessment, and as appropriate, any further actions.
- (d) Risk Assessment.
1. A risk assessment shall be conducted only by a person certified by the Commissioner as a risk assessor and in accordance with the procedures of this subparagraph.
  2. A visual inspection for risk assessment of the residential dwelling or child-occupied facility shall be undertaken to locate the existence of deteriorated paint, assess the extent and causes of the deterioration, and access other potential lead-based paint hazards.
  3. Background information regarding the physical characteristics of the residential dwelling or child-occupied facility and occupant use patterns that may cause lead-based paint exposure to one or more children aged six years and under shall be collected.
  4. The following surfaces that are determined, using documented methodologies, to have a distinct painting history, shall be tested for the presence of lead:
    - (i) Each friction surface or impact surface with visibly deteriorated paint; and
    - (ii) All other surfaces with visibly deteriorated paint.
  5. In residential dwellings, dust samples (either composite or single surface samples) from the interior windowsill(s) and floor shall be collected and analyzed for lead concentration in all living areas where one or more children, aged six and under, are most likely to come into contact with dust.
  6. For multi-family dwellings and child-occupied facilities, the samples required in part 4 of this subparagraph shall be taken. In addition, interior windowsill and floor-dust samples (either composite or single surface samples) shall be collected and analyzed for lead concentration in the following locations:
    - (i) Common areas adjacent to the sampled residential dwelling or child-occupied facility; and
    - (ii) Other common areas in the building where the risk assessor determines that one or more children aged six and under are likely to come into contact with dust.
  7. For child-occupied facilities, interior windowsill and floor-dust samples (either composite or single surface samples) shall be collected and analyzed for lead concentration in each room, hallway, or stairwell utilized by one or more children, age six and under, and in other common areas in the child-occupied facility where one or more children, age six and under, are likely to come into contact with dust.
  8. Soil samples shall be collected and analyzed for lead concentrations in the following locations:
    - (i) Exterior play areas where bare soil is present;
    - (ii) The rest of the yard (i.e., non-play areas) where bare soil is present; and
    - (iii) Drip line/foundation areas where bare soil is present.
  9. Any paint, dust, or soil sampling or testing shall be conducted using documented

methodologies that incorporate adequate quality control procedures.

10. Any collected paint chip, dust, or soil samples shall be analyzed according to subparagraph (g) of this paragraph to determine if they contain detectable levels of lead that can be quantified numerically.
11. The certified risk assessor shall prepare a risk assessment report that includes the following information:
  - (i) Date of assessment;
  - (ii) Address of each building;
  - (iii) Date of construction of buildings;
  - (iv) Apartment number (if applicable);
  - (v) Name, address, and telephone number of each owner of each building;
  - (vi) Name, signature, and certification of the certified risk assessor conducting the assessment;
  - (vii) Name, address, and telephone number of the certified firm employing each certified risk assessor if applicable;
  - (viii) Name, address, and telephone number of each recognized laboratory conducting analysis of collected samples;
  - (ix) Results of the visual inspection;
  - (x) Testing method and sampling procedure for paint analysis employed;
  - (xi) Specific locations of each painted component tested for the presence of lead;
  - (xii) All data collected from on-site testing, including quality control data and, if used, the serial number of any XRF device;
  - (xiii) All results of laboratory analysis on collected paint, soil, and dust samples;
  - (xiv) Any other sampling results;
  - (xv) Any background information collected pursuant to part 3 of this subparagraph;
  - (xvi) To the extent that they are used as part of the lead-based paint hazard determination, the results of any previous inspections or analyses for the presence of lead-based paint, or other assessments of lead-based paint-related hazards;
  - (xvii) A description of the location, type, and severity of identified lead-based paint hazards and any other potential lead hazards; and
  - (xviii) A description of interim controls and/or abatement options for each identified lead-based paint hazard and a suggested prioritization for addressing each hazard. If the use of an encapsulant or enclosure is recommended, the report shall recommend a maintenance and monitoring schedule for the encapsulant or enclosure.

(e) Lead Hazard Reduction Specifications.

1. The abatement and lead hazard reduction specifications shall be unique to each residential dwelling or child-occupied facility and shall be developed before the abatement and lead hazard reduction occurs.

2. The certified supervisor or project designer shall also provide to the project owner, for each specification package, a detailed cost estimate to complete the general requirements, project execution, and the lead hazard reduction and abatement.
3. The abatement and lead hazard reduction project specifications shall be written to include the following information:
  - (i) Date of each project specification;
  - (ii) Address of building;
  - (iii) Name, signature, and certification number of each certified supervisor and/or project designer writing the project specification;
  - (iv) Name, address, and telephone number of the certified firm employing each supervisor and/or project designer, if applicable;
  - (v) Building construction date;
  - (vi) Apartment numbers (if applicable);
  - (vii) General Requirements and Conditions:
    - (I) Description of work;
    - (II) Terminology/definitions;
    - (III) Applicable federal, state, and local regulations, standards and guidelines;
    - (IV) Contractor qualifications and responsibilities;
    - (V) Contractor's employee qualifications
    - (VI) Scheduling of lead hazard reduction;
    - (VII) Worker protection;
    - (VIII) Occupant protection plan; and
    - (IX) Site preparation and levels of protection pursuant to the containment erected;
  - (viii) Products;
  - (ix) Execution:
    - (I) Work area preparation; and
    - (II) Work area containment;
  - (x) Site-Specific Hazard Reduction Measures:
    - (I) Detailed specification and procedures for lead hazard reduction and abatement for each area;
    - (II) Detailed clean-up requirements and clearance testing;
    - (III) Disposal of lead-based paint materials and lead-based paint waste and debris;

- (IV) Contractor's air monitoring and analysis;
  - (V) Medical monitoring;
  - (VI) Logbook; and
  - (VII) Submittals;
  - (xi) Site Lead-based Paint Inspection/Risk Assessment Data Sheets;
  - (xii) Site sketch depicting interior floors, rooms, windows, and exterior construction and structures; and
  - (xiii) Contractor's bid proposal sheet.
- (f) Abatement and Lead Hazard Reductions.
1. An abatement or lead hazard reduction shall be conducted only by firms and individuals certified by the Commissioner and in accordance with the procedures of this subparagraph.
  2. A certified supervisor is required for each abatement project and shall be onsite during all work site preparation and during the post-abatement cleanup of work areas. At all other times when abatement activities are being conducted, the certified supervisor shall be onsite or available by telephone, pager, or answering service and able to be present at the work site in no more than two hours.
  3. The certified supervisor and the certified firm employing that supervisor shall ensure that all abatement activities are conducted according to the requirements of this paragraph and all other federal, state, and local requirements.
  4. The following shall be maintained on site during lead-based paint abatement and lead-hazard reduction activities and be immediately made available for review by the Commissioner:
    - (i) A copy of the project review notification, project review acknowledgement to proceed, and all revisions;
    - (ii) The occupant protection plan;
    - (iii) A copy of the applicable lead-based paint abatement design, risk assessment, and inspection reports;
    - (iv) Photo identification certification card issued by the Commissioner for all certified persons and firms performing lead-based paint activities; and
    - (v) A bound logbook that shall include, but not be limited to, copies of any accident and injury report, results of all air sampling, receipts from the landfill (trip tickets), daily inspection notes concerning any deviation from the standard working procedures, sign-in/sign-out sheets of site visitors and workers, and any other pertinent documents, permits, notification, photographs, and records. The information required to be maintained by this part may be maintained electronically so long as it is available at all times on site and available for review by the Commissioner.
  5. A written occupant protection plan shall be developed for all abatement projects in accordance with the following procedures:
    - (i) The occupant protection plan shall be submitted to the Commissioner at least five days before the commencement of the lead hazard reduction.
    - (ii) The occupant protection plan shall be signed by a principal of the certified firm that

is under contract to perform the lead hazard control and abatement activities and the person who prepared the plan.

- (iii) The occupant protection plan shall be unique to each residential dwelling or child-occupied facility and shall be developed before the abatement. The occupant protection plan shall describe the measures and management procedures that will be taken during the abatement to protect the building occupants from exposure to any lead-based paint hazards. If exterior abatement is being conducted, the plan should also include the protection of persons within 10 feet per building story of the building's exterior.
- (iv) Either a certified supervisor or project designer may prepare the occupant protection plan for a single-family dwelling, a multi-family dwelling with 10 or fewer units, or a child-occupied facility less than or equal to 1200 square feet or a conversion project less than or equal to 1200 square feet.
- (v) Only a certified project designer may prepare the occupant protection plan for multi-family dwellings with 11 or more units or a child-occupied facility equal to or greater than 1201 square feet or a conversion project equal to or greater than 1201 square feet.
- (vi) The occupant protection plan shall contain the work site preparation level of containment as specified in the following tables for interior, exterior, and window treatment lead hazard control activities:

Interior Worksite Preparation Levels (Not Including Windows)				
Description	Level 1	Level 2	Level 3	Level 4
Typical Application (Hazard Controls)	Dust removal and any abatement or interim control method disturbing no more than two square feet of painted surface per room	Any interim control or abatement method disturbing between two and 10 square feet of painted surface per room	Same as Level 2.	Any interim control or abatement method disturbing more than 10 square feet per room.
Time Limit Per Dwelling	One workday.	One workday.	Five workdays.	None.
Resident Location	Inside dwelling, but outside work area. Resident must have lead-safe passage to bathroom, at least one living area, and entry/egress pathways. Alternatively, resident can leave the dwelling during the work day.	Same as Level 1.	Outside the dwelling; but can return in evening after day's work and cleanup are completed. Resident must have safe passage to bathroom, at least one living area, and entry/egress pathways upon return. Alternatively, resident can leave the dwelling until all work is completed.	Outside the dwelling for duration of project; cannot return until clearance has been achieved.
Containment and Barrier System	Single layer of plastic sheeting on floor extending five	Two layers of plastic on entire floor. Plastic sheet	Two layers of plastic on entire floor. Plastic sheet	Two layers of plastic on entire floor. If entire unit is

	feet beyond the perimeter of the treated area in all directions. No plastic sheeting on doorways is required, but a low physical barrier (furniture, wood planking) to prevent inadvertent access by resident is recommended. Children should not have access to plastic sheeting (suffocation hazard).	with primitive airlock flap on all doorways. Doors secured from inside the work area need not be sealed. Children should not have access to plastic sheeting (suffocation hazard).	with primitive airlock flap on all doorways to work areas. Doors secured from inside the work area need not be sealed. Overnight barrier should be locked or firmly secured. Children should not have access to plastic sheeting (suffocation hazard).	being treated, cleaned, and cleared, individual room doorways need not be sealed. If only a few rooms are being treated, seal all doorways with primitive airlock flap to avoid cleaning entire dwelling. Doors secured from inside the work area need not be sealed.
Warning Signs	Required at entry to room but not on building (unless exterior work is also under way).	Same as Level 1.	Posted at main and secondary entryways.	Posted at building exterior near main and secondary entryways.
Ventilation System	Dwelling ventilation system turned off, but vents need not be sealed with plastic if they are more than five feet away from the surface being treated. Negative pressure zones (with "negative air" machines) are not required, unless large supplies of fresh air must be admitted into the work area to control exposures to other hazardous substances (for example, solvent vapors).	Turned off and all vents in room sealed with plastic. Negative pressure zones (with "negative air" machines) are not required, unless large supplies of fresh air must be admitted into the work area to control exposures to other hazardous substances (for example, solvent vapors).	Same as Level 2.	Same as Level 2.
Furniture	Left in place uncovered if furniture is more than five feet from working surface. If within five feet, furniture should be sealed with a single layer of plastic or moved for paint treatment. No covering is required for dust removal.	Removed from work area. Large items that cannot be moved can be sealed with a single layer of plastic sheeting and left in work area.	Same as Level 2.	Same as Level 2.

Cleanup (See Chapter 14 of the U.S. Department of Housing and Urban Development Guidelines for the Evaluation and Control of Lead-Based Paint Hazards in Housing for further discussion of cleanup methods)	HEPA vacuum, wet wash, and HEPA vacuum all surfaces and floors extending 5 feet in all directions from the treated surface. For dust removal work alone, a HEPA vacuum and wet wash cycle is adequate (i.e., no second pass with a HEPA vacuum is needed). Also, wet wash and HEPA vacuum floor in adjacent area (s) used as pathway to work area. Do not store debris inside dwelling overnight; transfer to a locked secure area at the end each day.	HEPA vacuum, wet wash, and HEPA vacuum all surfaces in room. Also, wet wash and HEPA vacuum floor in adjacent area(s) used as pathway to work area. Do not store debris inside dwelling overnight; use a secure locked area.	Remove top layer of plastic from floor and discard. Keep bottom layer of plastic on floor for use on the next day. HEPA vacuum, wet wash, and HEPA vacuum all surfaces in room. Also, wet wash and HEPA vacuum floor in adjacent area(s) used as pathway to work area. Do not store debris inside dwelling overnight; use a secure locked area.	Full HEPA vacuum, wet wash, and HEPA vacuum cycle, as detailed in Chapter 14 of the U.S. Department of Housing and Urban Development Guidelines for the Evaluation and Control of Lead-Based Paint Hazards in Housing.
Dust Sampling	Clearance only.	Clearance only.	One sample collected outside work area every few jobs plus clearance.	Clearance only.

Exterior Worksite Preparation Levels (Not Including Windows)			
Description	Level 1	Level 2	Level 3
Typical Applications	Any interim control or abatement method disturbing less than 10 square feet of exterior painted surface per dwelling. Also includes soil control work.	Any interim control or abatement method disturbing 10 to 50 square feet of exterior painted surface per dwelling. Also includes soil control work.	Any interim control or abatement method disturbing more than 50 square feet of exterior painted surface per dwelling. Also includes soil control work.
Time Limit Per Dwelling	One day.	None.	None.
Resident Location	Inside dwelling but outside work area for duration of project until cleanup has been completed. Alternatively, resident can leave until all work has been completed. Resident must have lead-safe access to entry/egress pathways.	Relocated from dwelling during workday but may return after daily cleanup has been completed.	Relocation from dwelling for duration of project until final clearance is achieved.
Containment and Barrier System	One layer of plastic on ground extending 10 feet beyond the perimeter of	Same as Level 1.	Same as Level 1.

	working surfaces. Do not anchor ladder feet on top of plastic (puncture the plastic to anchor ladders securely to ground). For all other exterior plastic surfaces, protect plastic with boards to prevent puncture from falling debris, nails, etc., if necessary. Raise edges of plastic to create a basin to prevent of unexpected precipitation. Secure plastic to side of building with tape or other anchoring system (no gaps between plastic and building). Weight all plastic sheets down with two-by-fours or similar objects. Keep all windows within 20 feet of working surfaces closed, including windows of adjacent structures.		
Playground Equipment, Toys, Sandbox	Remove all movable items to a 20-foot distance from working surfaces. Items that cannot be readily moved to a 20-foot distance can be sealed with taped plastic sheeting.	Same as Level 1.	Same as Level 1.
Signs	Post warning signs on the building and at a 20-foot perimeter around building (or less if distance to next building or sidewalk is less than 20 feet).	Same as Level 1.	Same as Level 1.
Weather	Do not conduct work if wind speeds are greater than 20 miles per hour. Work must stop and cleanup must occur before rain begins.	Same as Level 1.	Same as Level 1.
Porches	One lead-safe entryway must be made available to residents at all times. Do not treat front and rear porches at the same time if there is not a third doorway.	Front and rear porches cannot be treated at the same time if unprotected workers must use the entryway.	Same as Level 2.
Dust & Soil Sampling	Clearance only.	Clearance only.	Clearance only.
Porches	One lead-safe entryway must be made available to residents at all times. Do not treat front and rear porches at the same time if there is	Front and rear porches cannot be treated at the same time if unprotected workers must use the entryway.	Same as Level 2.

	not a third doorway		
--	---------------------	--	--

Window Treatment or Replacement Work Preparation Levels	
Appropriate Applications	Any Window Treatment or Replacement.
Resident Location	Remain inside dwelling but outside work area until project has been completed. Alternatively, can leave until all work has been completed. Resident must have access to lead-safe entry/egress pathway.
Time Limit Per Dwelling	None.
Containment and Barrier System	One layer of plastic sheeting on ground or floor extending five feet beyond perimeter of window being treated/replaced. Two layers of plastic taped to interior wall if working on window from outside; if working from the inside, tape two layers of plastic to exterior wall. If working from inside; implement a minimum Interior Worksite Preparation Level 2. Children cannot be present in an interior room where plastic sheeting is located due to suffocation hazard. Do not anchor ladder feet on top of plastic (puncture the plastic to anchor ladders securely to ground). For all other exterior plastic surfaces, protect plastic with boards to prevent puncture from falling debris, nails, etc. (if necessary). Secure plastic to side of building with tape or other anchoring system (no gaps between plastic and building). Weigh all plastic sheets down with two-by-fours or similar objects. All windows in dwelling should be kept closed. All windows in adjacent dwelling that are closer than 20 feet to the work area should be kept closed.
Signs	Post warning signs on the building and at a 20-foot perimeter around building (or less if distance to next building or sidewalk is less than 20 feet). If window is to be removed from inside, no exterior sign is necessary.
Security	Erect temporary fencing or barrier tape at a 20-foot perimeter around building (or less if distance to next building or sidewalk is less than 20 feet). Use a locked dumpster, covered truck, or locked room to store debris before disposal.
Weather	Do not conduct work if wind speeds are greater than 20 miles per hour. Work must stop and cleanup must occur before rain begins, or work should proceed from the inside only.
Playground Equipment, Toys, Sandbox	Removed from work area and adjacent areas. Remove all items to a 20-foot distance from dwelling. Large, unmovable items can be sealed with taped plastic sheeting.
Cleaning	If working from inside, HEPA vacuum, wet wash, and HEPA vacuum all interior surfaces within 10 feet of work area in all directions. If working from the exterior, no cleaning of the interior is needed, unless the containment is breached. Similarly, no cleaning is needed on the exterior if all work is done on the interior and the containment is not breached. If containment is breached, then cleaning on both sides of the window should be performed. No debris or plastic should be left out overnight if work is not completed. All debris must be kept in a secure area until final disposal.

6. After the commencement of an abatement project, all persons within a containment area shall be lead-based paint abatement personnel certified by the Commissioner.
7. The work practices listed below shall be restricted during an abatement as follows:
  - (i) Open-flame burning or torching of lead-based paint is prohibited;

- (ii) Machine sanding or grinding or abrasive blasting or sandblasting of lead-based paint is prohibited unless used with High Efficiency Particulate Air (HEPA) exhaust control that removes particles of 0.3 microns or larger from the air at 99.97 percent or greater efficiency;
  - (iii) Dry scraping of lead-based paint is permitted only in conjunction with heat guns or around electrical outlets or when treating defective paint spots totaling no more than two square feet in any one room, hallway, or stairwell or totaling no more than 20 square feet on exterior surfaces; and
  - (iv) Operating a heat gun on lead-based paint is permitted only at temperatures below 1100 degrees Fahrenheit.
8. Soil abatement shall be conducted as follows:
- (i) If soil is removed:
    - (I) Removed soil shall be replaced by soil with a lead concentration as close to local background as practicable, but no greater than 400 ppm.
    - (II) Removed soil shall not be used as topsoil at another residential property or child-occupied facility.
  - (ii) If soil is not removed, the soil shall be rendered permanently covered soil.
9. The following post-abatement clearance procedures shall be performed only by a certified inspector or risk assessor:
- (i) Following an abatement, a visual inspection shall be performed by a lead-based paint certified inspector or risk assessor to determine if deteriorated painted surfaces or visible amounts of dust, debris, or residue are still present. If deteriorated painted surfaces or visible amounts of dust, debris, or residue are present, these conditions must be eliminated prior to continuation of the clearance procedures.
  - (ii) Following the visual inspection and any post-abatement cleanup required by subpart (i) of this part, clearance sampling for lead in dust shall be conducted. Clearance sampling may be conducted by employing single-surface sampling or composite sampling techniques.
  - (iii) Dust samples for clearance purposes shall be taken using documented methodologies that incorporate adequate quality control procedures.
  - (iv) Dust samples for clearance purposes shall be taken a minimum of one hour after completion of final post-abatement cleanup activities.
  - (v) The following post-abatement clearance activities shall be conducted as appropriate based upon the extent or manner of abatement activities conducted in or to the residential dwelling or child-occupied facility:
    - (I) After conducting an abatement with containment between abated and unabated areas, one dust sample shall be taken from one interior windowsill and from one window trough (if present) and one dust sample shall be taken from the floors of each of no less than four rooms, hallways, or stairwells within the containment area. In addition, one dust sample shall be taken from the floor outside the containment area. If there are less than four rooms, hallways, or stairwells within the containment area, then all rooms, hallways, or stairwells shall be sampled.
    - (II) After conducting an abatement with no containment, two dust samples shall be taken from each of no less than four rooms, hallways, or stairwells

in the residential dwelling or child-occupied facility. One dust sample shall be taken from one interior windowsill and window trough (if present) of each room, and one dust sample shall be taken from the floor of each room, hallway, or stairwell selected. If there are less than four rooms, hallways, or stairwells within the residential dwelling or child-occupied facility then all rooms, hallways, or stairwells shall be sampled.

- (III) Following an exterior paint abatement, a visible inspection shall be conducted. All horizontal surfaces in the outdoor living area closest to the abated surface shall be found to be cleaned of visible dust and debris. In addition, a visual inspection shall be conducted to determine the presence of paint chips on the drip line or next to the foundation below any exterior surface abated. If paint chips are present, they must be removed from the site and properly disposed of according to all applicable federal, State, and local requirements.
  - (vi) The rooms, hallways, or stairwells selected for sampling shall be selected according to documented methodologies.
  - (vii) The certified inspector or risk assessor shall compare the residual lead level (as determined by the laboratory analysis) from each single surface dust sample with clearance levels in subpart (viii) of this part for lead in dust on floors, interior windowsills, and window troughs or from each composite dust sample with the applicable clearance levels for lead in dust on floors, interior windowsills, and window troughs divided by half the number of subsamples in the composite sample. If the residual lead level in a single surface dust sample equals or exceeds the applicable clearance level or if the residual lead level in a composite dust sample equals or exceeds the applicable clearance level divided by half the number of subsamples in the composite sample, the components represented by the failed sample shall be re-cleaned and retested.
  - (viii) The clearance levels for lead in dust are 10  $\mu\text{g}/\text{ft}^2$  for floors, 100  $\mu\text{g}/\text{ft}^2$  for interior windowsills, and 400  $\mu\text{g}/\text{ft}^2$  for window troughs.
10. In a multi-family dwelling with similarly constructed and maintained residential dwellings, random sampling for the purpose of clearance may be conducted provided:
- (i) The certified individuals who abate or clean the residential dwellings do not know which residential dwelling will be selected for the random sample.
  - (ii) A sufficient number of residential dwellings are selected for dust sampling to provide a 95% level of confidence that no more than 5% or 50 of the residential dwellings (whichever is smaller) in the randomly sampled population exceed the appropriate clearance levels.
  - (iii) The randomly selected residential dwellings shall be sampled and evaluated for clearance according to the procedures found in part 9 of this subparagraph.
11. An abatement report and project specifications shall be prepared by a certified supervisor or project designer for single family dwellings or multi-family dwellings with 10 or fewer units. A certified project designer shall prepare an abatement report and project specifications for child-occupied facilities and multi-family dwellings having 11 or more units. The completed abatement report shall be submitted to the Commissioner no more than 15 days following the completion of the abatement project. Any project specifications shall meet the requirements in part (e)3 of this paragraph. The abatement report shall include the following information:
- (i) Start and completion dates of abatement and a copy of the Project Review Acknowledgement to Proceed obtained from the Commissioner;
  - (ii) The name and address of each certified firm conducting the abatement and the

name of each supervisor assigned to the abatement project;

- (iii) The occupant protection plan prepared pursuant to part 5 of this subparagraph;
- (iv) The name, address, and signature of each certified risk assessor or inspector conducting clearance sampling and the date of clearance testing;
- (v) The results of clearance testing and all soil analyses (if applicable) and the name of each recognized laboratory that conducted the analyses; and
- (vi) A detailed written description of the abatement, including abatement methods used, locations of rooms and components where abatement occurred, the reason for selecting particular abatement methods for each component, and any suggested monitoring of encapsulants or enclosures.

(g) Collection and Laboratory Analysis of Samples.

Any paint chip, dust, or soil sample collected pursuant to the work practice standards contained in this paragraph shall be:

- 1. Collected by persons certified by the Commissioner as an inspector or risk assessor; and
- 2. Analyzed by a laboratory recognized by the National Lead Laboratory Accreditation Program or equivalent and capable of performing analyses for lead compounds in paint chip, dust, and soil samples pursuant to TSCA 15 U.S.C. § 2685(b) laboratory requirements.

(h) Composite Dust Sampling.

Composite dust sampling may only be conducted in the situations specified in subparagraphs (c), (d), and (f) of this paragraph. If such sampling is conducted, the following conditions apply:

- 1. Composite dust samples shall consist of at least two subsamples;
- 2. Every component that is being tested shall be included in the sampling; and
- 3. Composite dust samples shall not consist of subsamples from more than one type of component.

(i) Determinations.

- 1. Lead-based paint is present:
  - (i) On any surface that is tested and found to contain lead equal to or in excess of 1.0 milligrams per square centimeter or equal to or in excess of 0.5% by weight; or
  - (ii) On any surface like a surface tested in the same room equivalent that has a similar painting history and that is found to be lead-based paint.
- 2. A paint-lead hazard is present:
  - (i) On any friction surface that is subject to abrasion and where the lead dust levels on the nearest horizontal surface underneath the friction surface (e.g., the windowsill or floor) are equal to or greater than the dust hazard levels identified in subpart (f)9(viii) of this paragraph; or
  - (ii) On any chewable lead-based paint surface on which there is evidence of teeth marks; or
  - (iii) Where there is any damaged or otherwise deteriorated lead-based paint on an impact surface that is caused by impact from a related building component (such

as a doorknob that knocks into a wall or a door that knocks against its door frame);  
or

- (iv) If there is any other deteriorated lead-based paint in any residential building or child-occupied facility or on the exterior of any residential building or child-occupied facility.

3. A dust-lead hazard is present in a residential dwelling or child occupied facility:

- (i) In a residential dwelling on floors and interior windowsills when the weighted arithmetic mean lead loading for all single surface or composite samples of floors and interior windowsills window sills are equal to or greater than 10  $\mu\text{g}/\text{ft}^2$  for floors and 100  $\mu\text{g}/\text{ft}^2$  for interior windowsills, respectively;
- (ii) On floors or interior windowsills in an unsampled residential dwelling in a multi-family dwelling, if a dust-lead hazard is present on floors or interior windowsills, respectively, in at least one sampled residential unit on the property; and
- (iii) On floors or interior windowsills in an unsampled common area in a multi-family dwelling, if a dust-lead hazard is present on floors or interior windowsills, respectively, in at least one sampled common area in the same common area group on the property.

4. A soil-lead hazard is present:

- (i) In a play area when the soil-lead concentration from a composite play area sample of bare soil is equal to or greater than 400 parts per million; or
- (ii) In the rest of the yard when the arithmetic mean lead concentration from a composite sample (or arithmetic mean of composite samples) of bare soil from the rest of the yard (i.e., non-play areas) for each residential building on a property is equal to or greater than 1,200 parts per million.

(j) Recordkeeping.

All reports or plans required in this paragraph shall be maintained on site by the certified supervisor during abatement activities and by the certified firm or individual that prepared the report for no fewer than three years. The certified firm or individual also shall provide copies of these reports to the building owner who contracted for its services.

(k) Notification.

A certified firm must notify the Commissioner of lead-based paint activities as follows:

1. Except as provided in part 2 of this subparagraph, the Commissioner must be notified prior to conducting lead-based paint activities. The original notification must be received by the Commissioner at least five business days before the start date of any lead-based paint activities.
2. Notification for lead-based paint activities required in response to an elevated blood lead level (EBLL) determination, or federal, State, or local emergency abatement order, should be received by the Commissioner as early as possible before, but must be received no later than, the start date of the lead-based paint activities. Should the start date or location provided to the Commissioner change, an updated notification must be received by the Commissioner on or before the start date provided to the Commissioner. Documentation showing evidence of an EBLL determination or a copy of the federal, state, Tribal, or local emergency abatement order must be included in the written notification to take advantage of this abbreviated notification period.
3. Except as provided in part 2 of this subparagraph, updated notification must be provided

to the Commissioner for lead-based paint activities that will begin on a date other than the start date specified in the original notification as follows:

- (i) For lead-based paint activities beginning prior to the start date provided to the Commissioner, an updated notification must be received by the Commissioner at least five business days before the new start date included in the notification.
  - (ii) For lead-based paint activities beginning after the start date provided to the Commissioner, an updated notification must be received by the Commissioner on or before the start date provided to the Commissioner.
4. Except as provided in part 2 of this subparagraph, updated notification must be provided to the Commissioner for any change in location of lead-based paint activities at least five business days prior to the start date provided to the Commissioner.
5. Updated notification must be provided to the Commissioner when lead-based paint activities are canceled or when there are other significant changes including, but not limited to, when the square footage or acreage to be abated changes by more than 20%. This updated notification must be received by the Commissioner on or before the start date provided to the Commissioner, or if work has already begun, within 24 hours of the change.
6. The following must be included in each notification:
  - (i) Notification type (original, updated, cancellation);
  - (ii) Date when lead-based paint activities will start;
  - (iii) Date when lead-based paint activities will end (approximation using best professional judgment);
  - (iv) Firm's name, certification number, address, and telephone number;
  - (v) Type of building (e.g., single family dwelling, multi-family dwelling, child-occupied facilities) on/in which abatement work will be performed;
  - (vi) Property name (if applicable);
  - (vii) Property address including apartment or unit number(s) (if applicable) for abatement work;
  - (viii) If using the abbreviated time period as described in part 2 of this subparagraph, documentation showing evidence of an EBLL determination or a copy of the federal, State, Tribal, or local emergency abatement order;
  - (ix) Name and certification number of the project supervisor;
  - (x) Approximate square footage or acreage to be abated;
  - (xi) Brief description of abatement, risk assessment, inspection, lead hazard screen, lead hazard reduction, and clearance activities to be performed; and
  - (xii) Name, title, and signature of the representative of the certified firm who prepared the notification.
7. Notification must be made by written notification or electronically by such means approved by the Commissioner. Written notification can be accomplished using the Division form titled "Lead-Based Paint Activity Notification," or a successor to that form approved by the Commissioner. All written notification must be delivered by U.S. Postal Service, fax, commercial delivery service, or hand delivery.
8. In the event of changes to the original notification, lead-based paint activities shall not begin

on a date or at location other than that specified in either an original or updated notification.

9. No firm or individual shall engage in lead-based paint activities prior to notifying the Commissioner of such activities according to the requirements of this subparagraph.

(7) Lead-Based Paint Activities Requirements.

Lead-based paint activities shall only be conducted according to the procedures and work practice standards contained in paragraph (6) of this rule. No individual or firm may offer to perform or perform any lead-based paint activity unless properly certified by the Commissioner to perform that activity according to the procedures in paragraph (5) of this rule.

(8) Enforcement and Penalties.

Enforcement of the provisions of these rules and penalties for violations shall be as set forth in these rules and T.C.A. §§ 68-131-404 and 68-131-405.

(9) Inspections.

The Commissioner and the Commissioner's designated staff have the authority to enter any structure, including residences, where lead-based paint activities have occurred, or are being conducted, for the purpose of determining compliance with lead-based paint abatement requirements, provided they either:

- (a) Obtain the consent of the owner or an adult occupant of the premises after presenting credentials identifying themselves as employees of the Department; or
- (b) Apply for and obtain a warrant from a court with jurisdiction, which shall be issued by the court upon a showing of probable cause that the inhabitants of the dwelling are likely to suffer adverse health effects from continued exposure to a lead-based paint hazard.

(10) Fees for Accreditation, Certification, and Registration of Lead-Based Paint Activities.

(a) Purpose.

The purpose of this paragraph is to establish and impose fees for certified individuals and firms engaged in lead-based paint activities and persons operating accredited training programs and lead-based paint project review notifications.

(b) Persons who must pay fees.

Fee amounts in accordance with this paragraph must be paid by:

1. Training programs.

All training programs applying to the Commissioner for the accreditation and re-accreditation of training programs in one or more of the following disciplines: inspector, risk assessor, supervisor, project designer, and abatement worker.

2. Firms and Individuals.

All firms and individuals seeking certification and re-certification from the Commissioner to engage in lead-based paint activities in one or more of the following disciplines: inspector, risk assessor, supervisor, project designer, and abatement worker.

(c) Fee Amounts.

1. Application, project review notification, and other fees under this rule shall be as follows until June 30, 2024:

Training Program	Initial Application Fees	Re-accreditation [Every two years, see Rule
------------------	--------------------------	--

		0400-13-01-.01(4)(g)1.]
Initial Course		
Inspector	\$2,500	\$800
Risk Assessor	\$1,760	\$575
Supervisor	\$3,250	\$1,025
Worker	\$1,760	\$575
Project designer	\$1,010	\$355
Refresher Course		
Inspector	\$1,010	\$355
Risk Assessor	\$1,010	\$355
Supervisor	\$1,010	\$355
Worker	\$1,010	\$355
Project designer	\$640	\$245
Lead-based Paint Activities-Individual		
	Certification	Annual Registration Renewal
Inspector	\$200	\$ 100
Risk assessor	\$250	\$ 125
Supervisor	\$200	\$ 100
Worker	\$60	\$30
Project designer	\$300	\$ 150
Lead-based Paint Activities-Firm		
	Certification	Annual Registration Renewal
Firm	\$ 500	\$ 300
		Re-certification [every three years, see Rule 0400-13-01-.01(5)(c)1 for details.]
		Certification Renewal [every three years, see Rule 0400-13-01-.01(5)(d)7.]
		\$ 500

2. Application, project review notification, and other fees under this rule shall be as follows beginning July 1, 2024:

Training Program	Initial Application Fees	Re-accreditation [Every two years, see Rule 0400-13-01-.01(4)(g)1.]
Initial Course		
Inspector	\$4,150	\$1,350
Risk Assessor	\$2,900	\$1,350
Supervisor	\$5,400	\$1,675
Worker	\$2,900	\$1,350
Project designer	\$1,600	\$580
Refresher Course		
Inspector	\$1,300	\$800
Risk Assessor	\$1,300	\$800
Supervisor	\$1,300	\$800
Worker	\$1,300	\$800
Project designer	\$1,000	\$400
To Change or Add an individual as the Training Manager or Principal Instructor(s)		
	\$250	
Lead-Based Paint Activities – Individuals		
	Application Fees	Re-certification [every three years, see Rule 0400-13-01-.01(5)(c)1 for details.]
Inspector	\$675	\$675
Risk assessor	\$850	\$850
Supervisor	\$675	\$675

Worker Project designer	\$200 \$1,000	\$200 \$1,000
Certification ID Card Replacement	\$50	

Lead-Based Paint Activities Certification – Firm	Application Fees	Certification Application Fees for Firms [Every three years in accordance with Rule 0400-13-01-.01(5)(d)7.]
Lead-Based Paint Activity Firm	\$1,850	\$1,850
Replacement Firm Certificate	\$150	

Lead-Based Paint Activities – Project Review Notification Fee		
Abatement Type	Project Contract Cost	Project Review Notification Fee
All types of abatement in single family, multi-family, and child-occupied facilities	All abatement project costs	0.02 times project contract cost
Amended/revise project notification for all types of abatement in single family, multi-family and child-occupied facilities	All abatement project costs	\$50
All Lead-Based Paint inspections, risk assessments, occupant protection, plans, clearance sampling, and project specifications	Not applicable	No Fee

3. National Certification Exam Fee.

Individuals required to take a national certification exam in accordance with paragraph (5) of this rule will be assessed a fee of \$70 for each exam attempt.

4. Lost Certification Identification Card or Certificate.

A \$50 fee shall be charged for replacement of a registration card or a photo identification certification card or certificate.

(d) Photo Identification Certification Card or Certificate Replacement.

1. Parties seeking a photo identification certification card or a Certificate replacement shall complete the applicable portions of the appropriate application in accordance with the instructions provided. The appropriate applications are:

- (i) Individuals. “Application to Conduct Lead-based Paint Abatement Activities.”
- (ii) Firms. “Application to Conduct Lead-based Paint Abatement Activities.”
- (iii) Training Programs. “Accreditation Application for Training Programs.”

2. Submit application and payment in the amount specified in subparagraph (c) of this paragraph in accordance with the instructions provided with the application package.

(11) Reciprocity.

The Commissioner will seek to establish written reciprocal arrangements with other EPA-authorized states and Indian tribes that have established training program accreditation and individual certification requirements that meet or exceed the requirements of EPA outlined in 40 C.F.R. Part 745 Subpart L –Lead-Based Paint Activities and these rules. A training program reciprocity agreement may address cooperation in the approval determination, the review (inclusive of conducting record and course audits and compliance monitoring) of training programs, instructors, student testing, and examination administration, curriculum development, policy formulation, and the exchange of information and data. The Commissioner may grant accreditation of training programs and certification of individuals based on a reciprocity agreement provided the training program and individual completes the application process and payment of corresponding fees outlined in paragraph (10) of this rule. In addition, eligible servicemembers and spouses of servicemembers may secure accreditation in accordance with the provisions of T.C.A. § 4-3-1304(d) and 50 U.S.C. § 4025a (January 5, 2023).

Authority: T.C.A. §§ 11-1-101, 68-131-401 et seq., and 4-5-201 et seq.

0400-13-01-.02 Lead-Based Paint Hazards.

(1) Scope and Applicability.

- (a) This rule identifies lead-based paint hazards.
- (b) The standards for lead-based paint hazards in this rule apply to target housing and child-occupied facilities.
- (c) Nothing in this rule requires the owner of one or more properties subject to these standards to evaluate the property or properties for the presence of lead-based paint hazards or to take any action to control these conditions if one or more hazards is identified.
- (d) Identification of the lead hazards as defined on and after the effective date of this rule shall be disclosed to the property owner and occupants of the target housing and child-occupied facility.

(2) Definitions.

In addition to the definitions in Rule 0400-13-01-.01, the following definitions apply to this rule, unless otherwise specified:

“Wipe sample” means a sample collected by wiping a representative surface of known area, as determined by ASTM E1728, "Standard Practice for Field Collection of Settled Dust Samples Using Wipe Sampling Methods for Lead Determination by Atomic Spectrometry Techniques, or equivalent method, with an acceptable wipe material as defined in ASTM E 1792, "Standard Specification for Wipe Sampling Materials for Lead in Surface Dust", or equivalent method.

(3) Lead-Based Paint Hazards.

- (a) A paint-lead hazard is any of the following:
  - 1. Any lead-based paint on a friction surface that is subject to abrasion and where the lead dust levels on the nearest horizontal surface underneath the friction surface (e.g., the windowsill or floor) are equal to or greater than the dust-lead hazard levels identified in subparagraph (b) of this paragraph.
  - 2. Any damaged or otherwise deteriorated lead-based paint on an impact surface that is caused by impact from a related building component, such as a doorknob that knocks into a wall or a door that knocks against its door frame.
  - 3. Any chewable lead-based painted surface on which there is evidence of teeth marks.
  - 4. Any other deteriorated lead-based paint in any residential building or child-occupied facility or on the exterior of any residential building or child-occupied facility.

- (b) A dust-lead hazard is surface dust in a residential dwelling or child-occupied facility that contains a mass-per-area concentration of lead equal to or exceeding 10 µg/ft<sup>2</sup> on floors or 100 µg/ft<sup>2</sup> on interior windowsills based on wipe samples.
- (c) A soil-lead hazard is bare soil on residential real property or on the property of a child-occupied facility that contains total lead equal to or exceeding 400 parts per million (µg/g) in a play area or average of 1,200 parts per million of bare soil in the rest of the yard based on soil samples.
- (d) Applicable work practice standards and certification, occupant protection, and clearance requirements are found in Rule 0400-13-01-.01. The work practice standards in that rule do not apply when treating paint-lead hazards of less than:
  - 1. Two square feet of deteriorated lead-based paint per room or equivalent,
  - 2. Twenty square feet of deteriorated paint on the exterior building, or
  - 3. Ten percent of the total surface area of deteriorated paint on an interior or exterior type of component with a small surface area.

Authority: T.C.A. §§ 11-1-101, 68-131-401 et seq., and 4-5-201 et seq.

#### 0400-13-01-.03 Residential Property Renovation

##### (1) Purpose and Applicability.

- (a) The purpose of this rule is to require each person who performs a renovation of target housing for compensation to provide a lead hazard information pamphlet to the owner and occupant of such housing prior to commencing the renovation.
- (b) Except as provided in subparagraph (c) of this paragraph, this rule applies to all renovations of target housing performed for compensation.
- (c) This rule does not apply to renovation activities that are limited to the following:
  - 1. Minor repair and maintenance activities.
  - 2. Emergency renovation operations.
  - 3. Renovations in target housing in which a written determination has been made by an inspector (certified by the Commissioner pursuant to paragraph (5) of Rule 0400-13-01-.01) that the components affected by the renovation are free of paint or other surface coatings that contain lead equal to or in excess of 1.0 milligram per square centimeter or 0.5 percent by weight, where the renovator has obtained a copy of the determination.

##### (2) Definitions

In addition to the definitions in Rule 0400-13-01-.01, the following definitions apply to this rule, unless otherwise specified:

“The Act” means T.C.A. Title 68, Chapter 131, Part 4, Tennessee Lead-Based Paint Abatement Certification Act.

“Child-occupied facility” means a building or portion of a building, constructed prior to 1978, visited regularly by the same child, under six years of age, on at least two different days within any week (Sunday through Saturday period), provided that each day’s visit lasts at least three hours and the combined weekly visits last at least six hours, and the combined annual visits last at least 60 hours. Child-occupied facilities may include, but are not limited to, day care centers, preschools, and kindergarten classrooms. Child-occupied facilities may be located in target housing or in public or commercial buildings. With respect to common areas in public or commercial buildings that contain child-occupied facilities, the child-occupied facility encompasses only those common areas that are routinely used by children under age six, such as

restrooms and cafeterias. Common areas that children under age six only pass through, such as hallways, stairways, and garages are not included. In addition, with respect to exteriors of public or commercial buildings that contain child-occupied facilities, the child-occupied facility encompasses only the exterior sides of the building that are immediately adjacent to the child-occupied facility or the common areas routinely used by children under age six.

“Compensation” means payment for services rendered in the form of money, goods, or services and bartering.

“Emergency renovation operation” means renovation activities, such as operations necessitated by non-routine failures of equipment, that were not planned but result from a sudden, unexpected event that, if not immediately attended to, presents a safety or public health hazard, or threatens equipment and/or property with significant damage.

“Lessee” means any entity that enters into an agreement to lease, rent, or sublease target housing, including but not limited to individuals, partnerships, corporations, trusts, government agencies, housing agencies, Indian tribes, and nonprofit organizations.

“Minor repair and maintenance activities” are activities, including minor heating, ventilation or air conditioning work, electrical work, and plumbing, that disrupt six square feet or less of painted surface per room for interior activities or 20 square feet or less of painted surface for exterior activities where none of the work practices prohibited or restricted by subparagraph (6)(f) of Rule 0400-13-01-.01 are used and where the work does not involve window replacement or demolition of painted surface areas. When removing painted components, or portions of painted components, the entire surface area removed is the amount of painted surface disturbed. Jobs, other than emergency renovations, performed in the same room within the same 30 days must be considered the same job for the purpose of determining whether the job is a minor repair and maintenance activity.

“Multi-family housing” means a housing property consisting of more than four dwelling units.

“Pamphlet” means the EPA pamphlet developed under 15 U.S.C. § 2686(a) for use in complying with this and other rulemakings under TSCA 15 U.S.C. § 2686(b) and the Residential Lead-Based Paint Hazard Reduction Act, or any state or Tribal pamphlet approved by EPA pursuant to 40 C.F.R. § 745.326 that is developed for the same purpose. This includes reproductions of the pamphlet when copied in full and without revision or deletion of material from the pamphlet (except for the addition or revision of state or local sources of information.)

“Renovator” means an individual who either performs or directs workers who perform renovations. A certified renovator is a renovator who has successfully completed a renovator course accredited by EPA or an EPA-authorized state or Tribal program.

“Residential dwelling” means:

- (a) A single-family dwelling, including attached structures such as porches and stoops; or
- (b) A single-family dwelling unit in a structure that contains more than one separate residential dwelling unit, and in which each such unit is used or occupied, or intended to be used or occupied, in whole or in part, as the residence of one or more persons.

(3) Information Distribution Requirements.

(a) Renovation of Dwelling Units.

No more than 60 days before beginning renovation activities in any residential dwelling unit of target housing, the renovator shall:

1. Provide the owner of the unit with the pamphlet, and comply with one of the following:
  - (i) Obtain, from the owner, a written acknowledgment that the owner has received the pamphlet; or

(ii) Obtain a certificate of mailing at least seven days prior to the renovation.

2. In addition to the requirements in part 1 of this subparagraph, if the owner does not occupy the dwelling unit, provide an adult occupant of the unit with the pamphlet, and comply with one of the following:

(i) Obtain, from the adult occupant, a written acknowledgment that the occupant has received the pamphlet; or certify in writing that a pamphlet has been delivered to the dwelling and that the renovator has been unsuccessful in obtaining a written acknowledgment from an adult occupant. Such certification must include the address of the unit undergoing renovation, the date and method of delivery of the pamphlet, names of the persons delivering the pamphlet, reason for lack of acknowledgment (e.g., occupant refuses to sign, no adult occupant available), the signature the renovator, and the date of signature; or

(ii) Obtain a certificate of mailing at least seven days prior to the renovation.

(b) Renovations in Common Areas.

No more than 60 days before beginning renovation activities in common areas of multi-family housing, the renovator shall:

1. Provide the owner with the pamphlet, and comply with one of the following:

(i) Obtain, from the owner, a written acknowledgment that the owner has received the pamphlet; or

(ii) Obtain a certificate of mailing at least seven days prior to the renovation.

2. Notify in writing, or ensure written notification of, each unit of the multi-family housing and make the pamphlet available upon request prior to the start of renovation. Such notification shall be accomplished by distributing written notice to each affected unit. The notice shall describe the general nature and locations of the planned renovation activities; the expected starting and ending dates; and a statement of how the occupant can obtain the pamphlet, at no charge, from the renovator.

3. Prepare, sign, and date a statement describing the steps performed to notify all occupants of the intended renovation activities and to provide the pamphlet.

4. If the scope, locations, or expected starting and ending dates of the planned renovation activities change after the initial notification, the renovator must provide further written notification to the owners and occupants providing revised information on the ongoing or planned activities. This subsequent notification must be provided before the renovator initiates work beyond that described in the original notice.

(c) Written Acknowledgment.

Sample language for acknowledgment is provided in paragraph (6) of this rule. The written acknowledgments required in subparts (a)1(i), (a)2(i), and (b)1(i) of this paragraph shall:

1. Include a statement recording the owner or occupant's name and acknowledging receipt of the pamphlet prior to the start of renovation, the address of the unit undergoing renovation, the signature of the owner or occupant as applicable, and the date of signature;

2. Be either a separate sheet or part of any written contract or service agreement for the renovation; and

3. Be written in the same language as the text of the contract or agreement for the renovation or, in the case of non-owner-occupied target housing, in the same language as the lease or rental agreement or the pamphlet.

(4) Recordkeeping Requirements.

- (a) Renovators shall retain and, if requested, make available to the Commissioner all records necessary to demonstrate compliance with this rule for a period of three years following completion of the renovation activities in target housing.
- (b) Records that must be retained pursuant to subparagraph (a) of this paragraph include (where applicable):
  - 1. Reports certifying that a determination had been made by an inspector, certified pursuant to paragraph (5) of Rule 0400-13-01-.01, that lead-based paint is not present in the area affected by the renovation, as described in paragraph (1) of this rule;
  - 2. Signed and dated acknowledgments of receipt as described in subparts (3)(a)1(i), (3)(a)2(i), (3)(b)1(i), of this rule;
  - 3. Certifications of attempted delivery, as described in subpart (3)(a)2(i) of this rule;
  - 4. Certificates of mailing as described in subparts (3)(a)1(ii), (3)(a)2(ii), and (3)(b)1(ii) of this rule; and
  - 5. Records of notification activities performed regarding common area renovations, as described in parts (3)(b)3 and (3)(b)4 of this rule.

(5) Enforcement and Penalties.

Enforcement of these rules and penalties for violations are set forth in T.C.A. §§ 68-131-404 and 68-131-405.

(6) Acknowledgment and Certification Statements.

(a) Acknowledgment Statement.

- 1. As required under part (3)(c)1 of this rule, acknowledgments shall include a statement of receipt of the pamphlet prior to the start of renovation, the address of the unit undergoing renovation, the signature of the owner or occupant as applicable, and the date of signature.
- 2. The following is a sample of language that could be used for such acknowledgments:

I have received a copy of the pamphlet, *Protect Your Family From Lead In Your Home*, informing me of the potential risk of lead hazard exposure from renovation activity to be performed in my dwelling unit. I received this pamphlet before the work began.

Signature \_\_\_\_\_

Printed Name \_\_\_\_\_

Date \_\_\_\_\_

Unit Address \_\_\_\_\_

(b) Certification of Attempted Delivery.

- 1. When an occupant is unavailable for signature or refuses to sign the acknowledgment of receipt of the pamphlet, the renovator is permitted (per subpart (3)(a)2(i) of this rule) to certify delivery for each instance. The certification shall include the address of the unit undergoing renovation, the date and method of delivery of the pamphlet, names of the persons delivering the pamphlet, reason for lack of acknowledgment (e.g., occupant refuses to sign, no adult occupant available), the signature of the renovator, and the date of signature.

2. The following is a sample of language that could be used under those circumstances:

(i) Refusal To Sign.

I certify that I have made a good faith effort to deliver the pamphlet, *Protect Your Family From Lead In Your Home*, to the unit listed below at the dates and times indicated, and that the occupant refused to sign the acknowledgment. I further certify that I have left a copy of the pamphlet at the unit with the occupant.

Signature \_\_\_\_\_

Printed Name \_\_\_\_\_

Date \_\_\_\_\_

Unit Address \_\_\_\_\_

Attempted delivery dates and times: \_\_\_\_\_

(ii) Unavailable For Signature.

I certify that I have made a good faith effort to deliver the pamphlet, *Protect Your Family From Lead In Your Home*, to the unit listed below, and that the occupant was unavailable to sign the acknowledgment. I further certify that I have left a copy of the pamphlet at the unit with the occupant.

Signature \_\_\_\_\_

Printed Name \_\_\_\_\_

Date \_\_\_\_\_

Unit Address \_\_\_\_\_

Attempted delivery dates and times: \_\_\_\_\_

(7) Violations.

(a) It is a violation for a renovator to:

1. Fail or refuse to comply with any provision of this rule.
2. Fail or refuse to establish and maintain records required by paragraph (4) of this rule.
3. Fail to or refuse to make available to the Commissioner records as required by this rule.
4. Fail to or refuse to permit the Commissioner access to records as required by this rule.
5. Fail to or refuse to permit the Commissioner or the Commissioner's authorized representatives entry or inspection of the business premises of persons and firms engaged in renovation during business hours upon presenting credentials identifying themselves as employees of the department.

Authority: T.C.A. §§ 11-1-101, 68-131-401 et seq., and 4-5-201 et seq.

# **SECTION 4**

## **Occupant Protection Plan**

**TDEC DSWM Rule 0400-13-01-.01 (6)(f)(5) -  
Occupant Protection Plan Requirements**

**HUD Guidelines - Chapter 8: Resident Protection  
and Worksite Preparation**



STATE OF TENNESSEE  
 DEPARTMENT OF ENVIRONMENT AND CONSERVATION  
 DIVISION OF SOLID WASTE MANAGEMENT - TOXIC SUBSTANCES PROGRAM  
 DAVY CROCKETT TOWER, 7TH FLOOR  
 500 JAMES ROBERTSON PARKWAY  
 NASHVILLE, TN 37243

RETAIN A COPY OF THIS DOCUMENT ON SITE DURING LBP ABATEMENT AND LEAD-HAZARD REDUCTION ACTIVITIES

**OCCUPANT PROTECTION PLAN**

**\* A UNIQUE OCCUPANT PROTECTION PLAN (OPP) WILL BE DEVELOPED FOR EACH ABATEMENT PROJECT \***

**REFER TO THE RULES OF THE DEPARTMENT OF ENVIRONMENT AND CONSERVATION, DIVISION OF SOLID WASTE MANAGEMENT, CHAPTER 0400-13-01-.01(f)(5), LEAD-BASED PAINT ABATEMENT; AND REFER TO OTHER DOCUMENTED METHODOLOGIES FOUND IN 0400-13-01-.01(6)(a)(3).**

**A. DESCRIPTION OF WORKSITE**

PROPERTY NAME	ADDRESS	CITY	STATE	ZIP
OCCUPANT NAME	PHONE	PROPERTY OWNER PHONE		
OWNER NAME	ADDRESS	CITY	STATE	ZIP

**B. FIRM / CONTRACTOR INFORMATION**

FIRM / CONTRACTOR NAME	CERTIFICATION NUMBER	EXPIRATION DATE
STREET ADDRESS	CITY	STATE ZIP
PHONE	FAX	EMAIL ADDRESS

**C. PROJECT SITE SUPERVISOR**

NAME	CERTIFICATION NUMBER	EXPIRATION DATE
PHONE	FAX	EMAIL ADDRESS

**D. ABATEMENT ACTIVITY**

SITE DESCRIPTION:	PROJECT INCLUDES:	OTHER ACTIVITIES:
<input type="checkbox"/> WOOD SIDING	<input type="checkbox"/> INTERIOR WORK	<input type="checkbox"/> _____
<input type="checkbox"/> VINYL SIDING	<input type="checkbox"/> EXTERIOR WORK	<input type="checkbox"/> _____
<input type="checkbox"/> METAL SIDING	<input type="checkbox"/> SOIL REMOVAL	<input type="checkbox"/> _____
<input type="checkbox"/> BRICK / BLOCK	<input type="checkbox"/> INTERIOR WINDOW REMOVAL	<input type="checkbox"/> _____
<input type="checkbox"/> STUCCO	<input type="checkbox"/> EXTERIOR WINDOW REMOVAL	<input type="checkbox"/> _____

**E. WORKSITE PREPARATION — EXTERIOR**

#	TASK	PROCEDURE
1.	<b>RESIDENT LOCATION</b>	<input type="checkbox"/> CHILDREN WILL NOT BE PRESENT IN AREAS OF ABATEMENT, AND/OR WHERE 6-MIL POLY IS BEING USED DUE TO SUFFOCATION HAZARD. <input type="checkbox"/> RESIDENT(S) WILL BE RELOCATED FROM THE DWELLING FOR THE DURATION OF THE PROJECT UNTIL AFTER FINAL CLEARANCE IS ACHIEVED. <input type="checkbox"/> RESIDENT(S) MAY REMAIN INSIDE THE DWELLING BUT MUST BE AWAY FROM THE WORK AREA FOR THE DURATION OF THE PROJECT UNTIL AFTER FINAL CLEANUP AND CLEARANCE HAS BEEN ACHIEVED. <input type="checkbox"/> RESIDENT(S) WILL HAVE ACCESS TO LEAD-SAFE ENTRY/EGRESS PATHWAYS.

**E. WORKSITE PREPARATION — EXTERIOR (CONTINUED)**

#	TASK	PROCEDURE
1.	<b>RESIDENT LOCATION (CONTINUED)</b>	<input type="checkbox"/> RESIDENT(S) WILL LEAVE THE DWELLING WHILE WORK IS IN PROGRESS BUT MAY RETURN AFTER DAILY CLEANUP <b>(NOTE: REFER TO CHARTS AND SCENARIOS LOCATED IN CHAPTER 8 OF THE HUD GUIDELINES)</b>
2.	<b>SIGNS</b>	<input type="checkbox"/> WARNING SIGNS WILL BE POSTED ON THE BUILDING AT ALL ENTRANCES AND AT A 20-FOOT PERIMETER AROUND THE BUILDING. <input type="checkbox"/> WARNING SIGNS AND BARRIER TAPE WILL BE PLACED ON THE LOCKED DUMPSTER WHERE DEBRIS IS STORED BEFORE DISPOSAL.
3.	<b>SECURITY</b>	<input type="checkbox"/> TEMPORARY FENCING OR BARRIER TAPE WILL BE ERECTED AT A 20-FOOT PERIMETER AROUND THE WORKING SURFACES. <input type="checkbox"/> A LOCKED DUMPSTER WILL BE USED FOR THE DISPOSAL OF ALL DEBRIS.
4.	<b>CONTAINMENT AND BARRIER SYSTEM</b>	<input type="checkbox"/> ONE LAYER OF 6-MIL POLY WILL BE LAID ON GROUND EXTENDING 10 FEET BEYOND THE PERIMETER OF THE SURFACES UNDERGOING ABATEMENT. <input type="checkbox"/> FOR WORK ABOVE THE GROUND FLOOR, THE SHEETING WILL EXTEND 20 FEET BEYOND THE PERIMETER OF THE SURFACES UNDERGOING ABATEMENT. <input type="checkbox"/> 6-MIL POLY WILL BE ATTACHED TO THE BUILDING BY USING DUCT TAPE. A SECOND LAYER OF 6-MIL POLY WILL BE LAID ON TOP OF THE FIRST LAYER AND SECURED. <input type="checkbox"/> ALL WINDOWS WITHIN 20 FEET OF THE WORKING SURFACES WILL REMAIN CLOSED. <input type="checkbox"/> EDGES OF 6-MIL POLY WILL BE SLIGHTLY RAISED TO PREVENT RUNOFF OF CONTAMINATED WASTE IF GENERATED.
5.	<b>PLAYGROUND EQUIPMENT: SANDBOX, TOYS, ETC.</b>	<input type="checkbox"/> ALL MOVABLE ITEMS WILL BE REMOVED TO A 20-FOOT DISTANCE FROM THE WORKING SURFACES. <input type="checkbox"/> ALL ITEMS THAT ARE NOT MOVED WILL BE SEALED WITH 6-MIL POLY SHEETING.
6.	<b>PORCHES</b>	<input type="checkbox"/> ONE LEAD-SAFE ENTRYWAY MUST BE MADE AVAILABLE TO RESIDENT(S) AT ALL TIMES. <input type="checkbox"/> ALL DOORS LEADING INTO THE HOME WILL NOT BE TREATED SIMULTANEOUSLY.
7.	<b>CLEANUP</b>	<input type="checkbox"/> DEBRIS AND PLASTIC WILL NOT BE LEFT OUT OVERNIGHT IF WORK IS NOT COMPLETED BY END OF WORKDAY. <input type="checkbox"/> ALL DEBRIS WILL REMAIN IN A SECURE AREA UNTIL PROJECT IS COMPLETE.
8.	<b>WEATHER</b>	<input type="checkbox"/> WORK WILL NOT BE CONDUCTED WHEN WIND SPEEDS ARE IN EXCESS OF 20 MPH. <input type="checkbox"/> WORK WILL NOT CONTINUE IF RAINY CONDITIONS EXIST.

**F. WORKSITE PREPARATION — INTERIOR, NOT INCLUDING WINDOWS**

#	TASK	PROCEDURE
1.	<b>RESIDENT LOCATION</b>	<input type="checkbox"/> CHILDREN WILL NOT BE PRESENT IN AREAS OF ABATEMENT, AND/OR WHERE 6-MIL POLY IS BEING USED DUE TO SUFFOCATION HAZARD. <input type="checkbox"/> RESIDENT(S) WILL BE RELOCATED FROM THE DWELLING FOR THE DURATION OF THE PROJECT UNTIL FINAL CLEARANCE IS ACHIEVED. <input type="checkbox"/> RESIDENT(S) MAY REMAIN INSIDE THE DWELLING BUT MUST BE OUTSIDE THE WORK AREA FOR THE DURATION OF THE PROJECT UNTIL FINAL CLEANUP AND CLEARANCE HAS BEEN ACHIEVED. <input type="checkbox"/> IF RESIDENT(S) REMAIN INSIDE THE DWELLING DURING WORK HOURS, THEY WILL HAVE LEAD SAFE ACCESS TO SLEEPING AREAS, BATHROOM AND KITCHEN FACILITIES. <input type="checkbox"/> RESIDENT(S) WILL HAVE ACCESS TO LEAD-SAFE ENTRY/EGRESS PATHWAYS. <input type="checkbox"/> RESIDENT(S) WILL LEAVE THE DWELLING WHILE WORK IS IN PROGRESS, BUT MAY RETURN AFTER DAILY CLEANUP <b>(NOTE: REFER TO CHARTS AND SCENARIOS LOCATED IN CHAPTER 8 OF THE HUD GUIDELINES)</b>
2.	<b>SIGNS</b>	<input type="checkbox"/> WARNING SIGNS WILL BE POSTED ON THE BUILDING AT ALL ENTRANCES AND AT A 20-FOOT PERIMETER AROUND THE BUILDING. <input type="checkbox"/> IF RESIDENT(S) ARE NOT RELOCATED, WARNING SIGNS WILL BE POSTED AT THE ENTRY TO ROOMS WHERE ABATEMENT ACTIVITIES ARE OCCURRING. <input type="checkbox"/> WARNING SIGNS AND BARRIER TAPE WILL BE PLACED ON THE LOCKED DUMPSTER WHERE DEBRIS IS STORED PRIOR TO DISPOSAL.
3.	<b>SECURITY</b>	<input type="checkbox"/> TEMPORARY FENCING OR BARRIER TAPE WILL BE ERECTED AT A 20-FOOT PERIMETER AROUND THE WORKING SURFACES. <input type="checkbox"/> LOCKED DUMPSTERS WILL BE USED FOR THE DISPOSAL OF ALL DEBRIS.

**F. WORKSITE PREPARATION — INTERIOR, NOT INCLUDING WINDOWS (CONTINUED)**

#	TASK	PROCEDURE
4.	<b>CONTAINMENT AND BARRIER SYSTEM</b>	<input type="checkbox"/> TWO LAYERS OF 6-MIL POLY WILL BE PLACED ON THE ENTIRE FLOOR OF THE WORK AREA. <input type="checkbox"/> ALL DOORS WILL BE SEALED OR COVERED WITH 6-MIL POLY AIRLOCK FLAPS TO PREVENT CONTAMINATION IN ADJACENT ROOMS.
5.	<b>VENTILATION SYSTEM</b>	<input type="checkbox"/> VENTILATION SYSTEM(S) WILL BE SHUT OFF AND ALL VENTS IN WORK AREA WILL BE SEALED WITH 6-MIL POLY.
6.	<b>FURNISHINGS</b>	<input type="checkbox"/> FURNITURE AND FURNISHINGS WILL BE REMOVED FROM WORK AREA. <input type="checkbox"/> IN SOME INSTANCES, FURNITURE AND APPLIANCES WILL BE LEFT IN THE WORK AREA, BUT WILL BE COVERED USING 6-MIL POLY AND SEALED WITH MASKING TAPE.
7.	<b>CLEANUP</b>	<input type="checkbox"/> CONTAMINATED ITEMS WILL BE PROPERLY WRAPPED BEFORE REMOVING FROM THE WORK AREA. <input type="checkbox"/> DEBRIS WILL BE WRAPPED OR BAGGED AND STORED IN A SECURE AREA. <input type="checkbox"/> PROTECTIVE SHEETING AND AIRLOCK FLAPS WILL BE PATCHED AND REPAIRED. <input type="checkbox"/> PROTECTIVE SHEETING ON FLOORS AND BELONGINGS WILL BE VACUUMED WITH HEPA VACUUM. <input type="checkbox"/> OTHER HORIZONTAL SURFACES WITHIN 6 FEET OF TREATED SURFACES WILL BE HEPA VACUUMED. <input type="checkbox"/> FLOORS USED AS PASSAGeways TO THE WORK AREAS AND ANY AREAS USED FOR STORAGE OF TOOLS AND DEBRIS WILL BE VACUUMED AND WET CLEANED.
8.	<b>DUST SAMPLING</b>	<input type="checkbox"/> CLEARANCE SAMPLING WILL BE PERFORMED WHEN WORK IS COMPLETE AND BEFORE REOCCUPANCY.

**G. WORKSITE PREPARATION — WINDOW TREATMENT**

#	TASK	PROCEDURE
1.	<b>RESIDENT LOCATION</b>	<input type="checkbox"/> RESIDENT(S) WILL BE RELOCATED FROM THE DWELLING FOR THE DURATION OF THE PROJECT UNTIL FINAL CLEARANCE IS ACHIEVED. <input type="checkbox"/> RESIDENT(S) WILL LEAVE THE DWELLING WHILE WORK IS IN PROGRESS BUT MAY RETURN AFTER DAILY CLEANUP. <input type="checkbox"/> RESIDENT(S) MAY REMAIN INSIDE THE DWELLING, BUT MUST BE AWAY FROM THE WORK AREA FOR THE DURATION OF THE PROJECT UNTIL FINAL CLEANUP AND CLEARANCE HAS BEEN COMPLETED. RESIDENT(S) WILL HAVE ACCESS TO LEAD-SAFE ENTRY/EGRESS PATHWAY. <input type="checkbox"/> CHILDREN WILL NOT BE PRESENT IN AREAS OF ABATEMENT, AND/OR WHERE 6-MIL POLY IS BEING USED DUE TO SUFFOCATION HAZARD. <p>(NOTE: REFER TO CHARTS AND SCENARIOS LOCATED IN CHAPTER 8 OF THE HUD GUIDELINES)</p>
2.	<b>SIGNS</b>	<input type="checkbox"/> WARNING SIGNS WILL BE POSTED ON THE BUILDING AT ALL ENTRANCES AND AT A 20-FOOT PERIMETER AROUND THE BUILDING. <input type="checkbox"/> WARNING SIGNS AND BARRIER TAPE WILL BE PLACED ON THE LOCKED DUMPSTER WHERE DEBRIS IS STORED BEFORE DISPOSAL.
3.	<b>SECURITY</b>	<input type="checkbox"/> TEMPORARY FENCING OR BARRIER TAPE WILL BE ERECTED AT A 20-FOOT PERIMETER AROUND THE WORKING SURFACES. <input type="checkbox"/> LOCKED DUMPSTER(S) WILL BE USED FOR THE DISPOSAL OF ALL DEBRIS.
4.	<b>CONTAINMENT AND BARRIER SYSTEM - INTERIOR WINDOW REMOVAL</b>	<p><b>INTERIOR WINDOW REMOVAL / TREATMENT SCENARIO</b></p> <input type="checkbox"/> ALL WINDOWS IN ADJACENT DWELLINGS THAT ARE CLOSER THAN 20 FEET TO THE WORK AREA WILL BE CLOSED. <input type="checkbox"/> TWO LAYERS OF 6-MIL POLY WILL BE PLACED ON THE INTERIOR FLOOR DURING WINDOW REMOVAL AND/OR TREATMENT. <input type="checkbox"/> TWO LAYERS OF 6-MIL POLY WILL BE TAPED TO THE EXTERIOR OF THE WINDOW WALL WHEN WINDOWS ARE REMOVED FROM THE INSIDE <input type="checkbox"/> ONE LAYER OF 6-MIL POLY WILL BE PLACED ON THE GROUND EXTENDING 6 FEET BEYOND PERIMETER OF WINDOW BEING REMOVED AND/OR TREATED.
5.	<b>CONTAINMENT AND BARRIER SYSTEM - EXTERIOR WINDOW REMOVAL</b>	<p><b>EXTERIOR REMOVAL / TREATMENT SCENARIO</b></p> <input type="checkbox"/> ALL WINDOWS IN ADJACENT DWELLINGS THAT ARE CLOSER THAN 20 FEET TO THE WORK AREA WILL BE CLOSED. <input type="checkbox"/> ONE LAYER OF 6-MIL POLY WILL BE PLACED ON THE INTERIOR FLOOR IF WINDOWS ARE REMOVED FROM THE OUTSIDE. <input type="checkbox"/> TWO LAYERS OF 6-MIL POLY WILL BE TAPED TO THE INTERIOR OF THE WINDOW WALL WHEN WINDOWS ARE REMOVED FROM THE OUTSIDE. <input type="checkbox"/> ALL 6-MIL POLY ON THE EXTERIOR WILL BE SECURED BY SOME TYPE OF ANCHORING SYSTEM SUCH AS TWO BY FOURS.

**G. WORKSITE PREPARATION — WINDOW TREATMENT (CONTINUED)**

#	TASK	PROCEDURE
6.	<b>PLAYGROUND EQUIPMENT: SANDBOX, TOYS, ETC.</b>	<input type="checkbox"/> ALL MOVABLE ITEMS WILL BE MOVED 20-FOOT FROM THE WORK SURFACES. <input type="checkbox"/> ALL ITEMS THAT ARE NOT MOVED WILL BE SEALED WITH 6-MIL POLY SHEETING.
7.	<b>CLEANUP</b>	<input type="checkbox"/> 6-MIL POLY WILL BE REMOVED DAILY. <input type="checkbox"/> ALL ABATED SURFACES WILL BE HEPA VACUMMED, WET WASHED, RINSED, AND HEPA VACUUMED AGAIN. PATHWAYS TO WORK SURFACES WILL ALSO BE CLEANED USING THIS CLEANING CYCLE.
8.	<b>WEATHER</b>	<input type="checkbox"/> WORK WILL NOT BE CONDUCTED WHEN WIND SPEEDS ARE IN EXCESS OF 20 MPH. <input type="checkbox"/> WORK WILL NOT CONTINUE IF RAINY CONDITIONS EXIST.

**H. FINAL CLEANUP**

- ALL WINDOW TROUGHS WILL BE CLEANED.
- ALL HORIZONTAL SURFACES WITHIN 6 FEET OF WORK AREAS WILL BE VACUUMED AND WET CLEANED.
- PROTECTIVE SHEETING ON FLOORING WILL BE CLEANED AND REMOVED.
- THE FLOORS IN ADJACENT AREAS USED AS PATHWAYS TO THE WORK AREA WILL BE VACUUMED AND WET CLEANED.

**I. WORK SITE PREPARATION**

**WORK SITE PREPARATION WILL COINCIDE WITH THE RULES OF THE DEPARTMENT OF ENVIRONMENT AND CONSERVATION, DIVISION OF SOLID WASTE MANAGEMENT, CHAPTER 0400-13-01-.01 LEAD-BASED PAINT ABATEMENT; AND REFER TO OTHER DOCUMENTED METHODOLOGIES FOUND IN 0400-13-01-.01(6)(a)(1-4).**

**J. CERTIFICATION AND SIGNATURE**

FOR PROJECTS LESS THAN TEN UNITS, THIS OPP MUST BE PREPARED BY A LEAD SUPERVISOR OR PROJECT DESIGNER. FOR PROJECTS WITH TEN OR MORE UNITS, THE PLAN MUST BE PREPARED BY A PROJECT DESIGNER.

- LESS THAN 10 UNITS (SUPERVISOR OR PROJECT DESIGNER)
- 10 OR MORE UNITS (PROJECT DESIGNER)

The occupant protection plan shall be signed by a principal of the certified firm that is under contract to perform the lead hazard control and abatement activities and the person who prepared the plan.

I certify under penalty of law that this document and all attachments were prepared by me, or under my direction or supervision. The submitted information is to the best of my knowledge and belief, true, accurate, and complete. I am aware that there are significant penalties for submitting false information, including the possibility of fine and imprisonment. As specified in Tennessee Code Annotated Section 39-16-702(a)(4), this declaration is made under penalty of perjury.

_____ FIRM / CONTRACTOR REPRESENTATIVE SIGNATURE (DIGITAL SIGNATURE LOCKS FORM, DO THIS LAST)	_____ (PRINT) NAME OF REPRESENTATIVE
_____ (PRINT) NAME OF FIRM / CONTRACTOR	_____ DATE SIGNED (mm / dd / yyyy)
_____ REPRESENTATIVE CERTIFICATION #	_____ EXPIRATION DATE (mm / dd / yyyy)

**SUBMIT OCCUPANT PROTECTION PLAN BY MAIL OR MYTDEC**

<b>MAIL FORM TO:</b> STATE OF TENNESSEE DEPARTMENT OF ENVIRONMENT AND CONSERVATION DIVISION OF SOLID WASTE MANAGEMENT - TOXIC SUBSTANCES PROGRAM DAVY CROCKETT TOWER, 7TH FLOOR 500 JAMES ROBERTSON PARKWAY NASHVILLE, TN 37243	<b>FAX:</b>  Not acceptable for 'official documents'	<b>SUBMIT FORM:</b>  Submit form via <a href="#">MyTDEC Online Submissions Portal</a>
---	--	---

<b>REVIEWED BY:</b>	<b>PROJECT #</b>
---------------------	------------------

## Rule 0400-13-01-.01(6)(f)(5) Occupant Protection Plan Requirements

5. A written occupant protection plan shall be developed for all abatement projects in accordance with the following procedures:
  - (i) The occupant protection plan shall be submitted to the Commissioner at least five days before the commencement of the lead hazard reduction.
  - (ii) The occupant protection plan shall be signed by a principal of the certified firm that is under contract to perform the lead hazard control and abatement activities and the person who prepared the plan.
  - (iii) The occupant protection plan shall be unique to each residential dwelling or child-occupied facility and shall be developed before the abatement. The occupant protection plan shall describe the measures and management procedures that will be taken during the abatement to protect the building occupants from exposure to any lead-based paint hazards. If exterior abatement is being conducted, the plan should also include the protection of persons within 10 feet per building story of the building's exterior.
  - (iv) Either a certified supervisor or project designer may prepare the occupant protection plan for a single-family dwelling, a multi-family dwelling with 10 or fewer units, or a child-occupied facility less than or equal to 1200 square feet or a conversion project less than or equal to 1200 square feet.
  - (v) Only a certified project designer may prepare the occupant protection plan for multi-family dwellings with 11 or more units or a child-occupied facility equal to or greater than 1201 square feet or a conversion project equal to or greater than 1201 square feet.
  - (vi) The occupant protection plan shall contain the work site preparation level of containment as specified in the following tables for interior, exterior, and window treatment lead hazard control activities:

Interior Worksite Preparation Levels (Not Including Windows)				
Description	Level 1	Level 2	Level 3	Level 4
Typical Application (Hazard Controls)	Dust removal and any abatement or interim control method disturbing no more than two square feet of painted surface per room	Any interim control or abatement method disturbing between two and 10 square feet of painted surface per room	Same as Level 2.	Any interim control or abatement method disturbing more than 10 square feet per room.
Time Limit Per Dwelling	One workday.	One workday.	Five workdays.	None.
Resident Location	Inside dwelling, but outside work area. Resident must have lead-safe passage to bathroom, at least one living area, and entry/egress pathways. Alternatively, resident can leave	Same as Level 1.	Outside the dwelling; but can return in evening after day's work and cleanup are completed. Resident must have safe passage to bathroom, at least one living area, and	Outside the dwelling for duration of project; cannot return until clearance has been achieved.

	the dwelling during the work day.		entry/egress pathways upon return. Alternatively, resident can leave the dwelling until all work is completed.	
Containment and Barrier System	Single layer of plastic sheeting on floor extending five feet beyond the perimeter of the treated area in all directions. No plastic sheeting on doorways is required, but a low physical barrier (furniture, wood planking) to prevent inadvertent access by resident is recommended. Children should not have access to plastic sheeting (suffocation hazard).	Two layers of plastic on entire floor. Plastic sheet with primitive airlock flap on all doorways. Doors secured from inside the work area need not be sealed. Children should not have access to plastic sheeting (suffocation hazard).	Two layers of plastic on entire floor. Plastic sheet with primitive airlock flap on all doorways to work areas. Doors secured from inside the work area need not be sealed. Overnight barrier should be locked or firmly secured. Children should not have access to plastic sheeting (suffocation hazard).	Two layers of plastic on entire floor. If entire unit is being treated, cleaned, and cleared, individual room doorways need not be sealed. If only a few rooms are being treated, seal all doorways with primitive airlock flap to avoid cleaning entire dwelling. Doors secured from inside the work area need not be sealed.
Warning Signs	Required at entry to room but not on building (unless exterior work is also under way).	Same as Level 1.	Posted at main and secondary entryways.	Posted at building exterior near main and secondary entryways.
Ventilation System	Dwelling ventilation system turned off, but vents need not be sealed with plastic if they are more than five feet away from the surface being treated. Negative pressure zones (with "negative air" machines) are not required, unless large supplies of fresh air must be admitted into the work area to control exposures to other hazardous substances (for example, solvent vapors).	Turned off and all vents in room sealed with plastic. Negative pressure zones (with "negative air" machines) are not required, unless large supplies of fresh air must be admitted into the work area to control exposures to other hazardous substances (for example, solvent vapors).	Same as Level 2.	Same as Level 2.
Furniture	Left in place uncovered if furniture is more than five feet from	Removed from work area. Large items that cannot be moved can be	Same as Level 2.	Same as Level 2.

	working surface. If within five feet, furniture should be sealed with a single layer of plastic or moved for paint treatment. No covering is required for dust removal.	sealed with a single layer of plastic sheeting and left in work area.		
Cleanup (See Chapter 14 of the U.S. Department of Housing and Urban Development Guidelines for the Evaluation and Control of Lead-Based Paint Hazards in Housing for further discussion of cleanup methods)	HEPA vacuum, wet wash, and HEPA vacuum all surfaces and floors extending 5 feet in all directions from the treated surface. For dust removal work alone, a HEPA vacuum and wet wash cycle is adequate (i.e., no second pass with a HEPA vacuum is needed). Also, wet wash and HEPA vacuum floor in adjacent area (s) used as pathway to work area. Do not store debris inside dwelling overnight; transfer to a locked secure area at the end each day.	HEPA vacuum, wet wash, and HEPA vacuum all surfaces in room. Also, wet wash and HEPA vacuum floor in adjacent area(s) used as pathway to work area. Do not store debris inside dwelling overnight; use a secure locked area.	Remove top layer of plastic from floor and discard. Keep bottom layer of plastic on floor for use on the next day. HEPA vacuum, wet wash, and HEPA vacuum all surfaces in room. Also, wet wash and HEPA vacuum floor in adjacent area(s) used as pathway to work area. Do not store debris inside dwelling overnight; use a secure locked area.	Full HEPA vacuum, wet wash, and HEPA vacuum cycle, as detailed in Chapter 14 of the U.S. Department of Housing and Urban Development Guidelines for the Evaluation and Control of Lead-Based Paint Hazards in Housing.
Dust Sampling	Clearance only.	Clearance only.	One sample collected outside work area every few jobs plus clearance.	Clearance only.

Exterior Worksite Preparation Levels (Not Including Windows)			
Description	Level 1	Level 2	Level 3
Typical Applications	Any interim control or abatement method disturbing less than 10 square feet of exterior painted surface per dwelling. Also includes soil control work.	Any interim control or abatement method disturbing 10 to 50 square feet of exterior painted surface per dwelling. Also includes soil control work.	Any interim control or abatement method disturbing more than 50 square feet of exterior painted surface per dwelling. Also includes soil control work.
Time Limit Per Dwelling	One day.	None.	None.
Resident Location	Inside dwelling but outside work area for duration of project until cleanup has been completed.	Relocated from dwelling during workday but may return after daily cleanup has been completed.	Relocation from dwelling for duration of project until final clearance is achieved.

	Alternatively, resident can leave until all work has been completed. Resident must have lead-safe access to entry/egress pathways.		
Containment and Barrier System	One layer of plastic on ground extending 10 feet beyond the perimeter of working surfaces. Do not anchor ladder feet on top of plastic (puncture the plastic to anchor ladders securely to ground). For all other exterior plastic surfaces, protect plastic with boards to prevent puncture from falling debris, nails, etc., if necessary. Raise edges of plastic to create a basin to prevent of unexpected precipitation. Secure plastic to side of building with tape or other anchoring system (no gaps between plastic and building). Weight all plastic sheets down with two-by-fours or similar objects. Keep all windows within 20 feet of working surfaces closed, including windows of adjacent structures.	Same as Level 1.	Same as Level 1.
Playground Equipment, Toys, Sandbox	Remove all movable items to a 20-foot distance from working surfaces. Items that cannot be readily moved to a 20-foot distance can be sealed with taped plastic sheeting.	Same as Level 1.	Same as Level 1.
Signs	Post warning signs on the building and at a 20-foot perimeter around building (or less if distance to next building or sidewalk is less than 20 feet).	Same as Level 1.	Same as Level 1.
Weather	Do not conduct work if wind speeds are greater than 20 miles per hour. Work must stop and cleanup must occur before rain begins.	Same as Level 1.	Same as Level 1.
Porches	One lead-safe entryway must be made available to residents at all times. Do not treat front and rear porches at the same time if there is not a third doorway.	Front and rear porches cannot be treated at the same time if unprotected workers must use the entryway.	Same as Level 2.

Dust & Soil Sampling	Clearance only.	Clearance only.	Clearance only.
Porches	One lead-safe entryway must be made available to residents at all times. Do not treat front and rear porches at the same time if there is not a third doorway	Front and rear porches cannot be treated at the same time if unprotected workers must use the entryway.	Same as Level 2.

Window Treatment or Replacement Work Preparation Levels	
Appropriate Applications	Any Window Treatment or Replacement.
Resident Location	Remain inside dwelling but outside work area until project has been completed. Alternatively, can leave until all work has been completed. Resident must have access to lead-safe entry/egress pathway.
Time Limit Per Dwelling	None.
Containment and Barrier System	One layer of plastic sheeting on ground or floor extending five feet beyond perimeter of window being treated/replaced. Two layers of plastic taped to interior wall if working on window from outside; if working from the inside, tape two layers of plastic to exterior wall. If working from inside; implement a minimum Interior Worksite Preparation Level 2. Children cannot be present in an interior room where plastic sheeting is located due to suffocation hazard. Do not anchor ladder feet on top of plastic (puncture the plastic to anchor ladders securely to ground). For all other exterior plastic surfaces, protect plastic with boards to prevent puncture from falling debris, nails, etc. (if necessary). Secure plastic to side of building with tape or other anchoring system (no gaps between plastic and building). Weigh all plastic sheets down with two-by-fours or similar objects. All windows in dwelling should be kept closed. All windows in adjacent dwelling that are closer than 20 feet to the work area should be kept closed.
Signs	Post warning signs on the building and at a 20-foot perimeter around building (or less if distance to next building or sidewalk is less than 20 feet). If window is to be removed from inside, no exterior sign is necessary.
Security	Erect temporary fencing or barrier tape at a 20-foot perimeter around building (or less if distance to next building or sidewalk is less than 20 feet). Use a locked dumpster, covered truck, or locked room to store debris before disposal.
Weather	Do not conduct work if wind speeds are greater than 20 miles per hour. Work must stop and cleanup must occur before rain begins, or work should proceed from the inside only.
Playground Equipment, Toys, Sandbox	Removed from work area and adjacent areas. Remove all items to a 20-foot distance from dwelling. Large, unmovable items can be sealed with taped plastic sheeting.
Cleaning	If working from inside, HEPA vacuum, wet wash, and HEPA vacuum all interior surfaces within 10 feet of work area in all directions. If working from the exterior, no cleaning of the interior is needed, unless the containment is breached. Similarly, no cleaning is needed on the exterior if all work is done on the interior and the containment is not breached. If containment is breached, then cleaning on both sides of the window should be performed. No debris or plastic should be left out overnight if work is not completed. All debris must be kept in a secure area until final disposal.

---

## Chapter 8: Resident Protection and Worksite Preparation

HOW TO DO IT .....	8-3
I. Introduction .....	8-4
II. General Requirements and Other Guidance .....	8-4
A. Small Areas of Paint Disturbance, and Basic Good Work Practices .....	8-4
B. Resident Entry into Work Area Prohibited .....	8-5
C. Pre-Renovation Education .....	8-6
D. Written Occupant Protection Plan for Abatement Projects .....	8-7
E. Site Assessment and Pre-Cleaning .....	8-8
F. Vacuums: HEPA vs. non-HEPA .....	8-8
G. Worker Protection .....	8-8
H. Lead-Safe Work Practices .....	8-9
I. Debris Control .....	8-10
III. Worksite Preparation .....	8-10
A. Introduction .....	8-10
B. Interior Worksite Preparation .....	8-11
C. Worksite Preparation for Exterior Paint-Disturbing Work .....	8-24
1. Resident Location .....	8-24
2. Containment and Barrier System .....	8-24
3. Playground Equipment, Toys, Sandbox, and Outdoor Furniture .....	8-25
4. Security .....	8-26
5. Warning Signs .....	8-26
6. Weather .....	8-26
7. Cleanup .....	8-26
D. Worksite Preparation for Windows .....	8-27
E. Worksite Preparation for Soil-Lead Hazard Controls .....	8-28
IV. Temporary Relocation .....	8-29
A. When Is Relocation Necessary and What Are the Options? .....	8-29
1. Work Is a Small Area .....	8-29
2. Work Is Only on the Outside .....	8-29
3. Work and Clearance Take Only One Day .....	8-29
4. Work Area Is Limited and Work Is of Short Duration .....	8-30
5. Exception for Elderly Residents .....	8-30
B. What Relocation Units Are Acceptable? .....	8-32
C. Allowing Reoccupancy after Interim Clearance .....	8-32
D. Who Should Pay? .....	8-33
E. How Can Costs Be Minimized? .....	8-33

F. Communicating with Residents ..... 8-34

V. Negative Pressure Zones (“Negative Air” Machines) ..... 8-35

REFERENCES..... 8-37

**FIGURES**

Figure 8.1 Prohibiting resident entry into work area by use of containment barrier. .... 8-5

Figure 8.2 EPA “Renovate Right” Pamphlet. .... 8-7

Figure 8.3 Structural deficiency. .... 8-8

Figure 8.4 Example of structural deficiency needing repair prior to work. .... 8-8

Figure 8.5 One example of a commercial-type HEPA vacuum. .... 8-9

Figure 8.6 Inadequate worker protection during a large overhead paint stripping project. .... 8-9

Figure 8.7 Placing coffee station in the work area is an unsafe work practice. .... 8-9

Figure 8.8 Floor plastic in work area. .... 8-15

Figure 8.9 Plastic barrier between living space and work area. .... 8-16

Figure 8.10 Interior warning sign. .... 8-17

Figure 8.11 Exterior warning sign for project shown in Figure 8.10..... 8-17

Figure 8.12 Items that are too large to move should be sealed completely and taped..... 8-19

Figure 8.13 Removal and wrapping contaminated carpet. .... 8-20

Figure 8.14 Exterior containment of polyethylene sheeting lines the narrow walkway between two houses..... 8-25

Figure 8.15 Exterior containment on building and window; ladder kept on plywood..... 8-25

Figure 8.16 Example of barrier tape used as an occupant protection measure..... 8-26

Figure 8.17 Pre-cleaning window with HEPA vacuum. .... 8-27

Figure 8.18 Sample Informed Consent Form for Residents of Housing for the Elderly. .... 8-31

**TABLES**

Table 8.1 Interior Worksite Preparation (Not Including Windows)..... 8-13

# Chapter 8: Resident Protection and Worksite Preparation

## How to Do It

1. If possible, perform the work in a vacant unit. If this is not possible, relocate residents if the work in their unit will last for more than a short time. If residents must remain inside the dwelling during work, appropriate containment and barrier systems as described in this chapter should be installed. Never permit residents to enter a work area where work disturbing known or presumed lead-based paint, or cleanup of lead-contaminated dust or soil, is underway. See Section IV, Temporary Relocation.
2. Determine requirements for relocation, isolation of work areas, and other worksite preparation measures based on the type and extent of the work and the amount of dust that will be generated. Use guidance in Section III of this chapter. Avoid high-dust jobs and procedures, if at all possible.
3. Perform pre-renovation education about lead-based paint hazards as required by EPA regulations and some State, tribal and/or local requirements. Consider providing pre-renovation education even if the regulations do not require doing so.
4. Determine if the dwelling will require pre-cleaning before worksite containment. (See Section II.E.) If the paint is severely deteriorated and paint chips or dust or debris are present, vacuum the floor before protective sheeting is laid down.
5. Implement relocation plan, if needed, and begin worksite preparation.
6. Restrict access to the work area. As noted above, never permit residents to enter the work area. When clearance or cleaning verification is performed, entry should be denied until cleaning is complete, and clearance or cleaning verification, as applicable, has been achieved. If clearance or cleaning verification has not been achieved at the end of the day, keep the barriers in place overnight and instruct residents not to enter the work area. Exceptions to these rules are available for elderly residents and hardship cases. See Section IV.A.5.
7. Conduct daily cleanup. See the Cleanup row of Table 8.1.
8. Perform a visual examination daily. Conduct this examination to ensure that dust, debris and residue outside the contained work area are removed, and that the contained area has been cleaned up adequately by the daily cleanup.
9. Perform final cleanup after work is finished. See the Cleanup row of Table 8.1.
10. Do not allow residents to reoccupy the work area until a clearance examination, or cleaning verification, as applicable, has been passed. See the item 10, Clearance, in the How to Do It list at the start of Chapter 11.
11. Notification of residents. The property owner or manager should notify residents of what lead-based paint hazards were controlled and how, and the results of the clearance examination or cleaning verification, as applicable – HUD recommends that the residents be notified whether or not the work is federally assisted (if the work is not federally assisted, only the person who ordered the work must be informed of its results).

## I. Introduction

Many forms of paint-disturbing work, including renovation, maintenance, and rehabilitation, as well as lead hazard controls, generate varying amounts of leaded dust, paint chips, and other lead-contaminated materials. This chapter describes ways to protect residents and the environment from exposure to, or contamination from, these materials. Some types of work require complete isolation, or containment, of the work area and/or full evacuation of the residents and their belongings. Other jobs require much less site preparation and containment.

Containment refers to various methods of preventing leaded dust from migrating beyond the work area. It includes a variety of measures, including the simple use of disposable, impermeable protective sheeting as drop cloths, the sealing of doors and vents with such sheeting using tape, and measures taken by workers to keep from tracking leaded dust into non-work areas. The required degree of containment depends upon a number of considerations, including: the amount of dust that will be generated (which is affected by the nature of the work and the work practices that are used); resident re` possibilities; the size of the work area; the duration of the job; whether the work is interior or exterior or both; the construction skill levels of workers applicable to their performing specific tasks on the job; and whether there will be air movement within an interior work area due to open windows.

Generally speaking, only small-scale activity should be conducted in occupied units; significant lead hazard control work should be performed in units from which residents have been temporarily relocated or units that are otherwise vacant. Worksite preparation is needed for both interim controls and abatement work. It is also recommended, and sometimes required, for renovation and maintenance jobs if lead-based paint is or may be disturbed.

This chapter describes the general principles behind resident protection and proper worksite preparation. Guidance is provided for interior work, exterior work, window work, and soil-lead hazard control.

Activities that are required by HUD or EPA are identified in this chapter as being “required” or as actions that “must” be done. Activities that are not required by HUD but are recommended by these *Guidelines* are identified as being “recommended” or as actions that “should” be done. Activities that may be done at the discretion of the owner, manager, or contractor are identified as “optional.”

## II. General Requirements and Other Guidance

### A. Small Areas of Paint Disturbance, and Basic Good Work Practices

HUD and EPA regulations do not require the resident protection and worksite preparation practices described in this chapter for non-abatement work if the total amount of disturbed painted surfaces falls within what the HUD Lead Safe Housing Rule (LSHR) (see Appendix 6) refers to as a *de minimis amount*, i.e., a very small area that can be repaired without trained workers, lead-safe work practices or a clearance examination. This small area threshold, which applies to HUD-assisted and HUD-owned housing (and work on other housing that uses the LSHR threshold, inclusive of state and local laws) referred to here as the *de minimis*, is a disruption of no more than:

- + 20 square feet (2 square meters) on exterior surfaces;
- + 2 square feet (0.2 square meters) in any one interior room or space; or
- + 10 percent of the total surface area on an interior or exterior type of component with a small surface area, such as window sills, baseboards, and trim.

EPA excludes from coverage under its Renovation, Repair, and Painting (RRP) Rule (see Appendix 6), a somewhat larger area of interior work than HUD does under its Lead Safe Housing Rule, but does not have an exclusion for work on small amounts of components with small surface areas. EPA's regulatory exclusion is for what the agency calls "minor repair and maintenance activities," which are those that disrupt no more than:

- + 6 square feet or less of painted surface per room for interior activities; or +
- 20 square feet or less of painted surface for exterior activities;

provided that:

- + the work practices prohibited or restricted by the RRP Rule are **not** used; and
- + the work does **not** involve window replacement or demolition of painted surface areas.

(Note that the EPA does not have a minimum size threshold for coverage of its lead abatement rule (see Appendix 6), and that some State, Tribal and local regulations may not recognize these thresholds and may cover work above a smaller threshold or work of any size, however small.)

However, dry scraping or dry sanding even a small amount of lead-based paint can create a lot of lead-contaminated dust, so these *Guidelines* recommend that the following minimal good work practices always be observed when disturbing paint in pre-1978 housing, unless it is known that all layers of paint to be disturbed are not lead-based paint: (the Lead Safe Housing Rule does allow for a limited exception from lead-safe work practices (LSWP; see Section II.D of Chapter 11) on post-1977 components):

- 1) Never use the prohibited methods of paint removal that are described in Section III.C.1 of Chapter 6 and Section II.D.1 of Chapter 11; and
- 2) When disturbing paint, always keep residents and pets out of the work area while work is underway and until after the cleanup, and clean the work area thoroughly after finishing, preferably with both high efficiency particulate air (HEPA) vacuuming and wet cleaning.



**FIGURE 8.1 Prohibiting resident entry into work area by use of containment barrier.**

## **B. Resident Entry into Work Area Prohibited**

In projects covered by the HUD LSHR, and/or the EPA RRP Rule *residents must never be permitted to enter the work area while work is under way. Furthermore, resident reentry into the work area is permitted only after the area has been cleaned and, if required, has passed clearance* (under the LSHR or, optionally, under the RRP Rule) *or cleaning verification* (under the RRP Rule) (see Figure 8.1). While the two rules allow residents to remain in the work area when work that disturbs less the applicable small area threshold is being conducted, both agencies strongly discourage that practice.

All of the worksite preparation strategies discussed in this chapter are based on this fundamental approach. While residents may not be present inside the work area for work covered by the regulations, it is possible for the residents to remain inside other parts of the dwelling during some types of work, or to

leave for the day and return to the dwelling at night after cleaning, visual evaluation for dust, debris and residue outside of the contained area, and collection of dust samples.

### **C. Pre-Renovation Education**

EPA's RRP regulations amended the Pre-Renovation Education requirements (PRE) by requiring that people who perform renovation of most pre-1978 housing for compensation provide a lead renovation pamphlet to owners and occupants before beginning the renovation (40 CFR 745.84). (See below for information on the pamphlet.) The information contained in the lead renovation pamphlet that is given to owners and occupants before beginning the renovation should be provided in appropriate format(s) to meet the needs of all residents including persons with limited English proficiency and in formats that may be needed for persons who are visually or hearing impaired (Executive Order 13166, derived from Title VI of the Civil Rights Act of 1964).

Renovation is defined in the regulation broadly as "the modification of any existing structure, or portion thereof, that results in the disturbance of painted surfaces, unless that activity is performed as part of an abatement as defined by this part" (40 CFR 745.223). Note that EPA requires resident protection whenever abatement of lead-based paint hazards is being conducted (40 CFR 745.227(e)(5)).

This pre-renovation education requirement does *not* apply to minor repair and maintenance activities, as described above, emergency renovations; renovations of components that have been found by a certified lead-based paint inspector or a certified renovator to be free of lead-based paint; or housing that is not target housing (housing built after 1977, housing that is exclusively for the elderly or persons with disabilities (provided a child of less than 6 does not reside there), and zero-bedroom units).

Emergency renovations are those activities that were not planned but result from a sudden, unexpected event (such as non-routine failures of equipment) that, if not immediately attended to, presents a safety or public health hazard, or threatens equipment and/or property with significant damage; and also interim controls performed in response to an elevated blood lead level in a resident child (see Chapter 16). The RRP rule requires that before work begins, the contractor must give the occupants the EPA pamphlet titled "Renovate Right: Important Lead Hazard Information for Families, Child Care Providers and Schools" in English, and "Guía de Prácticas Acreditadas Seguras para Trabajar con el Plomo para Remodelar Correctamente" ("Remodelar Correctamente") in Spanish, or any State or Tribal pamphlet approved by EPA for the same purpose.

Copies of "Renovate Right" can be obtained from the National Lead Information Center, at 1-800-424-LEAD, or by downloading it from the EPA's or HUD's web site. As of the publication of these *Guidelines*, the pamphlet is available in English and Spanish:

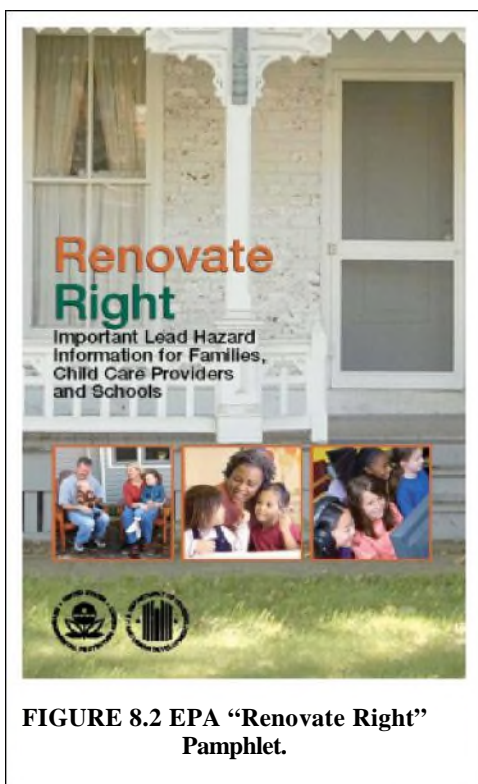

**FIGURE 8.2 EPA “Renovate Right” Pamphlet.**

- + On the EPA website, the English version is available at <http://www.epa.gov/lead/pubs/renovaterightbrochure.pdf>, and the Spanish version, at <http://www.epa.gov/lead/pubs/renovaterightbrochure-esp.pdf>.
- + On the HUD website, the English version is available at: <http://portal.hud.gov/hudportal/documents/huddoc?id=renovaterightbrochure.pdf>.

State or Tribe is authorized to operate its lead program for abatement, at <http://www.epa.gov/oppt/lead/pubs/traincert.htm>, and/or for renovation, at <http://www.epa.gov/lead/pubs/renovation.htm>. Links are provided to individual authorized abatement and renovation programs if they are available. Addresses and links of the EPA Regional Lead Coordinators are provided for States and Tribal areas for which EPA operates the certification and accreditation programs, at EPA’s Where You Live lead page, at <http://www.epa.gov/lead/pubs/leadoff1.htm>. The sites also provide the forms and instructions provided to apply for accreditation or certification for EPA-operated programs. You can get additional assistance from the National Lead Information Center (NLIC) at 800-424-LEAD (5323); hearing- or speech-challenged individuals may access this number through TTY by calling the toll-free Federal Relay Service at 800-877-8339.

### D. Written Occupant Protection Plan for Abatement Projects

EPA regulations require that a written occupant protection plan be developed for all abatement projects (40 CFR 745.227(e)(5)). The term “abatement,” as defined by EPA, “means any measure or set of measures designed to permanently eliminate lead-based paint hazards.” It “does not include renovation, remodeling, landscaping or other activities, when such activities are not designed to permanently eliminate lead-based paint hazards, ... even though these activities may incidentally result in a reduction or elimination of lead-based paint hazards.” (40 CFR 745.223). The occupant protection plan is required to:

- + be unique to the dwelling or facility;
- + be developed before the abatement;
- + describe the measures and procedures that will be taken to protect the occupants from exposure to lead-based paint hazards; and
- + be prepared by a certified lead-based paint abatement supervisor or certified project designer.

**E. Site Assessment and Pre-Cleaning**

If structural deficiencies exist, they have to be corrected before the site can be prepared for paint-disturbing work (see Figures 8.3 and 8.4). Worksite preparation, resident, environmental, and worker protection is required to be provided if the structural repairs will involve disturbance of surfaces coated with lead-based paint.

If the paint is deteriorated and there are paint chips or dust or debris present, vacuum the floor before protective sheeting is laid down (see the next subsection). Vacuuming will prevent the paint chips from being ground into dust by the workers' feet. Wet cleaning usually is not required for pre-cleaning.

**F. Vacuums: HEPA vs. non-HEPA**

Vacuum cleaners used for cleaning up dust as a lead hazard control measure must be high efficiency particulate air (HEPA) vacuums if the work is covered by OSHA's Lead in Construction rule, EPA's RRP Rule, or HUD's LSHR. (See Appendix 6, and, in particular, 29 CFR 1926.62(h)(4), 40 CFR 745.85(b)(2)(A) and (B), and 24 CFR 35.145 and 150(b), respectively.)

HEPA vacuums differ from conventional vacuums in that they contain high-efficiency filters that are capable of trapping extremely small, micron-sized particles. These filters can remove particles of 0.3 microns or greater from air at 99.97 percent efficiency or greater. (A micron is 1 millionth of a meter, or about 0.00004 of an inch.) See figure 8.5.

There is more to a vacuum than the filter. Other important factors that determine the effectiveness of a vacuum are velocity suction (which is a function of the motor, the design of the suction tool, and the extent to which the rest of the system does not release air before it is supposed to), quality of construction (which may determine the durability of the machine and whether there are air pressure leaks before the filtration), and whether the vacuum has special tools, such as a crevice tool. (See the further discussion of "Selecting a vacuum" in Chapter 11, section V.B.2.)

**G. Worker Protection**

Workers must be protected from exposure to lead by wearing protective clothing, practicing personal hygiene, and using lead-safe work practices (see Figure 8.6). Regardless of the size or dustiness of the job, OSHA requires that employers perform exposure monitoring of workers to determine the

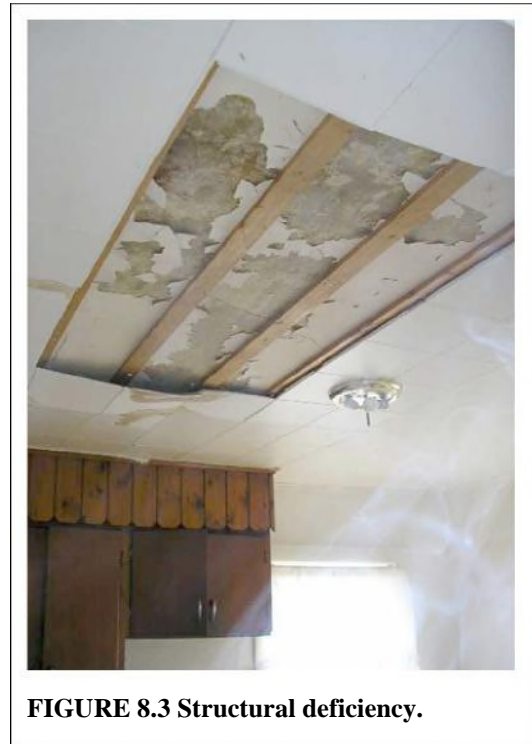

**FIGURE 8.3 Structural deficiency.**



**FIGURE 8.4 Example of structural deficiency needing repair prior to work.**



**FIGURE 8.5** One example of a commercial-type HEPA vacuum.



**FIGURE 8.6** Inadequate worker protection during a large overhead paint stripping project. Depending on exposure, this worker should be wearing protective clothing, long chemical-resistant gloves and a respirator; and should also be protected against falls.

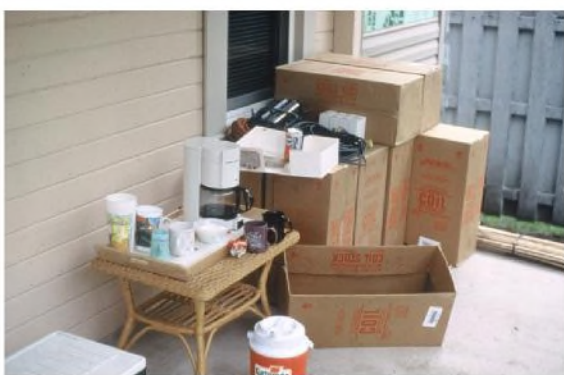

**FIGURE 8.7** Placing coffee station in the work area is an unsafe work practice.

protective measures that are needed. Refer to 29 CFR 1926.62(g), Protective Work Clothing and Equipment, for specific requirements. These protective measures will help protect workers' families, because leaded dust will not be brought home, and will contribute to protecting the homes where they are working from lead contamination. Generally, protective clothing can include eye protection (always recommended), coveralls, head and hair protection (a painter's hat or a hard hat), disposable cotton gloves, latex/rubber gloves (when using detergents), disposable booties, and, if applicable, appropriate respiratory protection.

Personal hygiene includes the following "don'ts:"

- + No smoking;
- + No eating;
- + No drinking (see Figure 8.7 for an unsafe work practice);
- + No chewing; and
- + No applying cosmetics in the work area.

Workers who perform these "don't" activities with lead on their hands put themselves at risk of ingesting lead. Workers should always wash their face and hands with soap and water before eating, drinking, or smoking and before leaving the site. Clothing should be changed before leaving the worksite. Tools should be cleaned.

Paint-removal practices described in Section II.D of Chapter 11 reduce the amount of dust created by the work and thus the likelihood of worker exposure. For complete information on worker protection, consult Chapter 9.

### H. Lead-Safe Work Practices

Workers performing paint-disturbing work should use lead-safe work practices, in accordance with guidance at Section II.D of Chapter 11. Overall, this means that workers must never use prohibited paint-removal practices, should work wet to dampen dust spread (except where this would create an electrical safety hazard), and should clean up thoroughly after the work. During paint-disturbing work, painted surfaces should be wetted with a fine mist of water or water mixed with a surfactant before scraping or sanding to reduce generation of airborne paint dust, followed by wet HEPA vacuuming. Appropriate consideration should be given to potential electrical hazards that may be created by the presence of water. In addition, the occupant protection and worksite preparation measures described in this chapter are part of lead-safe work practices.

## I. Debris Control

In general, see the discussion of debris control throughout Table 8.1, below.

In *occupied dwellings*, ensuring that cleaning of interior and exterior work areas is conducted as the work progresses and at the end of each work day or work shift is essential for conducting paint-disturbing work safely. Neither debris nor protective sheeting may be left outside the dwelling overnight or in any area where passersby, especially children, could come into contact with these materials. These practices prevent the spread of lead-contaminated dust. EPA's RRP rule requires dust to be contained at the end of each work day regardless of whether the dwelling is occupied.

These *Guidelines* additionally note that *continual cleaning* is especially important when residents are present in the dwelling while work is in progress, or when residents return in the evening after work has been completed for the day. (See Section IV, Temporary Relocation, below.) When residents cannot be relocated and work is staged to proceed room by room, clearance standards may be more difficult to meet because dust from moved furniture may cause recontamination. In this situation, it is recommended that furniture be cleaned before moving it to an area where work and cleaning have been completed.

All debris is required to be handled and disposed of in accordance with the standards outlined in Chapter 10.

## III. Worksite Preparation

### A. Introduction

This section provides guidance on worksite preparation for interior and exterior paint-disturbing work, and it provides separate guidance for work on windows and for soil-lead hazard control. All recommendations in this section include the use of lead-safe work practices, including, most importantly, compliance with prohibitions against certain paint-removal practices described in Section II.D of Chapter 11.

The general purpose of worksite preparation is to minimize, contain, and control dust and debris created by the work. There are five objectives for worksite preparation:

- + Protect residents and workers from exposure to lead in dust, paint chips, and other debris created by the work.
- + Protect residents' belongings from contamination with lead.
- + Leave the surfaces of dwellings and common areas free of dust-lead hazards.
- + Protect the exterior environment, both on and off the subject property, from contamination.
- + Protect adjacent homes from contamination.

The measures recommended in this chapter help protect workers from exposing themselves to lead in dust, contaminating their cars and homes, and endangering their children.

Factors affecting the worksite preparation measures needed for a specific job include the following:

- + The amount and spread of dust likely to be created by the job, which in turn is affected by the size of the surfaces needing work; the location of the work (e.g., ceiling vs. lower wall); and the nature of the work and the methods being used. For example, the enclosure of walls may require a lower worksite preparation level than the wet scraping of a large area because enclosure will disturb less paint and generate less dust. Similarly, demolition associated with replacement of deteriorated components will probably require a higher containment level than the wet scraping of a small area.
- + The amount of air movement in the work area.
- + The location of residents.
- + The building layout.
- + The proximity of the building to other properties.
- + The extent to which there will be other construction or abatement work (e.g., renovation or asbestos abatement) that will be concurrent or sequential with the work being planned.
- + Worker protection needs may also be a factor.

EPA's RRP rule requires that dust not leave the work area. These *Guidelines* are performance-oriented and are not specifications. It is possible to devise a unique worksite preparation approach for an individual dwelling if it achieves the five objectives stated above and if clearance, if required, is achieved. Containment measures should be designed to prevent the release of lead-containing dust, which can be spread by workers' shoes or by airborne dust.

Whatever combination of containment measures is selected, the levels of lead in dust outside the containment area must not rise above clearance levels. A previously conducted risk assessment, or selective dust testing conducted for this purpose, will indicate if hazardous dust-lead levels exist outside the containment area. If dust-lead levels rise in the course of the work, it is reasonable to conclude that the dust was released from the containment area and that the containment system is ineffective. Dust sampling is usually conducted no farther than 10 feet away from the containment area, but this may vary if visual monitoring indicates that dust may have spread farther than 10 feet. If deviations from the worksite preparation plans described below are contemplated, then the performance of the containment system should be determined by a person certified in the State to collect dust samples. This flexibility permits owners to select the most cost-effective strategy while also protecting the public health and the environment.

## **B. Interior Worksite Preparation**

These *Guidelines* provide, in Table 8.1, two sets of recommendations for *interior* work (not including windows) – one for “low-dust” jobs and one for “high-dust” jobs. (Recommendations for window work are provided in Section III.D, below.)

The approach of categorizing a project by the amount of dust it may generate (“high dust” / “low dust”), in order to describe suitable measures taken to protect the safety of the housing for each category, is analogous to the approach OSHA uses for characterizing worker exposures to lead and the suitable protective measures for workers taken for exposures in each worker airborne lead exposure range, although the residential protection “high” / “low” distinction is defined based on the spread of leaded dust, rather than the airborne dust levels, and is less quantitative.

A low-dust job is work that creates a small amount of dust that will not spread beyond 6 feet from the painted surfaces being disturbed. A high-dust job creates a large amount of dust that is expected to spread beyond 6 feet from the working surfaces. Work disturbing more than 10 square feet of painted surface per room is likely to be a high-dust job, while work that disturbs less than 10 square feet will probably be a low-dust job. These are very rough indicators, however. Dust spread depends on the elevation of the work surface, air movement, and whether methods are used to dampen dust dispersal as well as reduce the amount of paint being disturbed and the amount of dust being generated.

All work involving lead-based paint should be performed in a manner that minimizes all dust production. *High-dust operations should be avoided if at all feasible.* All work should be designed to reduce all dust generation to protect children, workers and residents using work practices and procedures such as wet work practices and the use of tools with attached HEPA-vacuum exhaust.

**Table 8.1 Interior Worksite Preparation  
(Not Including Windows)**

Note: This table does not relieve employers from the exposure assessments and other requirements of OSHA regulations. For example, employers are responsible for determining whether a work area is at or above the Action Level or Permissible Exposure Limit for airborne lead, and undertaking any required engineering controls, administrative controls and personal protective equipment controls.

Description	Low-Dust Jobs	High-Dust Jobs (High-dust operations should be avoided if at all feasible.)
Typical Types of Work	<p>A low-dust job creates a small amount of dust that will not spread beyond 6 feet from the painted surfaces being disturbed, depending on the type of work performed. Work that disturbs less than 10 square feet of painted surface per room will probably be a low-dust job, again depending on the type of work performed. The following tasks are also generally considered low-dust jobs: routine repairs, such as re-hanging doors, replacing or repairing door locks, patching small holes in walls, small electrical repair jobs, and routine repainting that involves a small amount of wet scraping and/or wet sanding for surface preparation. Enclosure and encapsulation may be low-dust jobs if little surface preparation and disturbance of paint is required.</p>	<p>A high-dust job creates a large amount of dust that is expected to spread beyond 6 feet from the working surfaces, depending on the job. Work disturbing more than 10 square feet of painted surface per room is likely to be a high-dust job. The following are also generally considered high dust-generating activities: demolition of painted surfaces, including removal of interior walls, paneling, baseboards, door casings or frames, cabinets, flooring, or ceilings; pulling up old wall-to-wall carpeting improperly (see Chapter 11); paint scraping of large areas, such as a whole room, even when done wet; using a circular or reciprocating saw on painted surfaces; and removing dry residue and paint after using chemical strippers.</p>
Resident Location	<p>Residents must be outside the rooms where the work will be done until after final clearance is achieved (or, if cleaning verification is being conducted, after the cleaning is verified), i.e., after results of dust sampling show that dust-lead levels are below applicable standards (or visual examination of the cleaning verification wipe indicates that the cleaning is verified).</p> <p>If the housing or the work is federally-assisted, the resident relocation provisions of HUD’s Lead Safe Housing Rule (LSHR) must be followed. The LSHR requires residents to be temporarily relocated to a suitable, decent, safe, and similarly accessible dwelling unit that does not have lead-based paint hazards – see Section IV.B,</p>	<p>SAME AS FOR LOW-DUST JOBS, EXCEPT that HUD recommends temporary relocation of residents to a suitable, decent, safe, and similarly accessible dwelling unit that does not have lead-based paint hazards, for jobs lasting more than five consecutive calendar days even if neither the housing nor the work is not covered by the LSHR.</p>

Description	Low-Dust Jobs	High-Dust Jobs (High-dust operations should be avoided if at all feasible.)
Resident Location (continued)	<p>below, on how to determine if the relocation unit is acceptable – except in certain situations, including those below. It requires relocation of residents for jobs lasting more than five consecutive calendar days and has other requirements (See Appendix 6 and the LSHR at 24 CFR 35.1345(a)(2).).</p> <p>If residents are not being temporarily relocated, the worksite must be contained and the work and clearance or cleaning verification, if they will be conducted, will not be completed in one 8-hour work day, residents must have lead-safe access to sleeping areas, and bathroom and kitchen facilities. If bathrooms are not accessible, residents should be relocated, unless alternative arrangements can be made (e.g., use of a neighbor’s bathroom).</p> <p>If construction will result in other hazards (such as exposed electric wires), then residents should be relocated.</p> <p>The dwelling unit and the worksite should be secured, and occupants’ belongings protected from contamination.</p>	
Containment and Barrier Systems	<p>To catch dust, paint chips, and other debris created by the work, place a single layer of impermeable protective sheeting (e.g., plastic) on the floor extending at least 6 feet out in all directions from each painted surface being disturbed. Workers should extend protective sheeting farther if they think dust generated by the work will spread, or in fact is spreading, beyond 6 feet.</p> <p>When dust and debris spread beyond 6 feet, workers should follow high-dust methods, depending on the job.</p> <p>If work on the flooring is part of the job, it is generally not necessary to put protective</p>	<p>Place two layers of protective sheeting on the entire floor of rooms where work is being done, in passageways used by workers going to and from the work area, and other areas used for storage of tools or debris. Two layers of protective sheeting should be used for all jobs in which damage to the sheeting is likely. (See Figure 8.8.) Usually the top sheet will be damaged and the bottom sheet will protect the floor.</p> <p>Torn or punctured sheeting should be repaired each day.</p> <p>Protective sheeting on floors should be a heavy-duty, disposable, impermeable</p>

Description	Low-Dust Jobs	High-Dust Jobs (High-dust operations should be avoided if at all feasible.)
<p>Containment and Barrier Systems (continued)</p>	<p>sheeting on the floor if the non-floor work is low dust.</p> <p>Protective sheeting on floors should be a heavy-duty, disposable, impermeable covering, such as polyethylene or vinyl plastic sheeting to resist tearing or puncture during the work. Plastic sheeting of 6 mils thickness is generally recommended for floors, but a thinner grade may be satisfactory for jobs of short duration with light traffic and no abrasion. Adhesive-backed floor protection films may be useful. Protective sheeting on floors must be able to withstand vacuuming the work area. Do not use cloth canvas drop cloths; they can transfer retained leaded dust from job to job.</p> <p>Do not track dust off the protective sheeting onto unprotected flooring. Workers and others leaving the work area must clean themselves before they do in order not to track dust off of plastic sheeting. Wear disposable non-skid shoe covers ("booties") when on protective sheeting and remove them each time you step off the sheeting. Alternatives to using booties are: (1) wipe both the top and bottom of your shoes with a damp paper towel each time you step off the sheeting;</p> <div data-bbox="444 1423 948 1835" data-label="Image"> </div> <p><b>FIGURE 8.8 Floor plastic in work area.</b></p>	<p>covering, such as polyethylene or vinyl plastic sheeting of 6 mils or greater thickness to resist tearing or puncture during the work. . Adhesive-backed floor protection films may be useful. Protective sheeting on floors must be able to withstand vacuuming.</p> <p>Workers and others leaving the work area must clean themselves before they do in order not to track dust off of plastic sheeting. Lighter impermeable sheeting, such as "painter's poly," may be used to protect immovable objects within the work area. Do not use cloth drop cloths; they can transfer retained leaded dust from job to job.</p> <p>If only a few rooms in a dwelling unit are being treated, install protective sheeting with a simple airlock flap on doorways to avoid having to clean and clear the entire dwelling. Even if the entire dwelling is to be cleaned and cleared, it is helpful to install protective sheeting in doorways to work areas to reduce the spread of dust.</p> <p>Simple airlocks are constructed using two sheets of protective sheeting. The first one is taped on the top, the floor, and both sides of the doorway with a vertical fold in the middle to allow slack. Next, cut a slit about 6 feet high down the middle of the plastic; do not cut the slit all the way down to the floor. Tape the second sheet of plastic, placed on the side of the first sheet facing the work area, across the top of the door only, so that it acts as a flap. The flap should open into the work area. (See illustrated guidance on this method in the <i>Lead Paint Safety Field Guide</i> (HUD, 2001), page 46.)</p> <p>Doorways within a containment area need not be sealed if the work area is isolated from the rest of the unit. If the entire dwelling unit is being treated, cleaned and cleared, doorways need not be sealed.</p>

Description	Low-Dust Jobs	High-Dust Jobs (High-dust operations should be avoided if at all feasible.)
Containment and Barrier Systems (continued)	<p>(2) clean the bottom of your shoes using a tack pad (a large sticky pad that is taped to the protective sheeting and helps remove dust) every time you step off the sheeting; and (3) remove shoes every time you step off the protective sheeting. The drawbacks to these alternatives are: (1) heavily treaded work boots may be difficult to clean; (2) the effectiveness of the tack pad may become compromised after a period of use; and (3) going without shoes in non-work areas is risky to the feet.</p> <p>A physical barrier should be placed at doorways to prevent inadvertent access by residents. If the work and collection of clearance dust samples will not be completed in one day, there should be an overnight barrier that is locked or firmly secured to prevent access to rooms where work is being done (see Figure 8.9). Children should not have access to protective sheeting because of the suffocation hazard.</p> <p>All personnel, tools, and other items, including the exteriors of containers of waste, must be kept free of dust and debris before leaving the work area.</p>  <p><b>FIGURE 8.9 Plastic barrier between living space and work area.</b></p>	<p>Place protective sheeting on the floors of passageways to be used by workers going from high-dust work areas to the outside. This facilitates daily cleanup of the work areas and encourages workers to use the protected passageways. Do not track dust off the protective sheeting onto unprotected floor. Wear disposable non-skid shoe covers (“booties”) when on protective sheeting and remove them each time you step off the sheeting. Alternatives to using booties are: (1) wipe both the top and bottom of your shoes with a damp paper towel each time you step off the sheeting; (2) clean the bottom of your shoes using a tack pad (a large sticky pad that is taped to the protective sheeting and helps remove dust) every time you step off the sheeting; and (3) remove shoes every time you step off the protective sheeting. The drawbacks to these alternatives are: (1) heavily treaded work boots may be difficult to clean; (2) the effectiveness of the tack pad may become compromised after a period of use; and (3) going without shoes in non-work areas is risky to the feet. If the work and clearance will not be completed in one day, there should be an overnight barrier that is locked or firmly secured to prevent access to rooms where work is being done. Children should not have access to protective sheeting (suffocation hazard).</p> <p>All personnel, tools, and other items, including the exteriors of containers of waste, must be kept free of dust and debris before leaving the work area.</p>



Description	Low-Dust Jobs	High-Dust Jobs (High-dust operations should be avoided if at all feasible.)
Warning Signs	<p>If residents are present, place warning signs at the entry to work-area rooms or the containment area and at each main and secondary entryway to the building or, for work in multi-family housing, the unit; if the work is to be done in a common area, place the warning signs at the entries to that area (see Figure 8.10 and 11). Warning signs should be in the language(s) understandable to residents and workers. Recommended wording is: "Warning. Lead Work Area. Poison. No Smoking or Eating." Wording can be adapted as appropriate to project-specific conditions. The EPA's RRP rule has sign requirements for renovations (see Appendix 6).</p> <p>OSHA warning signs are required when worker exposures exceed OSHA's permissible exposure limit for airborne lead; see Chapter 9.</p>	<p>SAME AS FOR LOW-DUST JOBS.</p>
	<p style="text-align: center;">FIGURE 8.10 Interior warning sign.</p>	<p style="text-align: center;">FIGURE 8.11 Exterior warning sign for project shown in Figure 8.10</p>

Description	Low-Dust Jobs	High-Dust Jobs (High-dust operations should be avoided if at all feasible.)
Ventilation	<p>To contain dust, air movement should be minimal in work areas while painted surfaces are being disturbed and while cleaning is being conducted.</p> <p>Fans should be turned off, and windows should be closed. The HVAC system should be turned off. Forced-air duct vents within the work area of surfaces being treated and at least 6 feet beyond should be covered with protective sheeting and taped.</p> <p>Doorways in the work area must be closed, and covered with plastic sheeting or other impermeable material.</p> <p>(If volatile substances are to be used, such as certain types of paint strippers, a source of fresh air should be provided and manufacturer's instructions followed in order to ensure protection of the workers.</p> <p>Open windows usually are the available source of fresh air. An alternative source of fresh air to open windows is negative air; see Section V, below. If windows are to be opened, then, in order to minimize dispersal of leaded dust, open as few windows as need be to protect the works, use high-dust containment methods (see above), and conduct the work with the volatile substances first followed by other paint-disturbing work with the windows closed.)</p> <p>Painting can be done with windows open and HVAC system on, provided the work has passed clearance or cleaning has been verified, and paint fumes will not be carried to other areas causing danger or discomfort.</p>	<p>SAME AS FOR LOW-DUST JOBS.</p>

Description	Low-Dust Jobs	High-Dust Jobs (High-dust operations should be avoided if at all feasible.)
Furniture and Resident's Belongings	<p>Remove drapes, curtains, furniture, rugs, and other resident belongings from the work area, that is, to at least 6 feet away from surfaces being treated, and cover and seal with taped impermeable protective sheeting all large furniture and other large items that cannot be moved (see Figure 8.12). If there will be air movement due to open windows, remove all belongings from rooms in which work is being done or cover and seal with taped protective sheeting.</p>	<p>SAME AS FOR LOW-DUST JOBS.</p>  <p><b>FIGURE 8.12</b> Items that are too large to move should be sealed completely and taped.</p>
Cleanup	<p><b>Daily cleanup:</b> The purposes of daily cleanings are: (1) to help assure that workers will not be exposed to accumulated dust-lead; (2) to make it more likely that the work area will pass the initial clearance examination after one final cleanup; and (3) to protect residents after final cleanup.</p> <p>If residents are present in part of the dwellings, daily cleaning provides protection against accidental resident exposure, especially after work hours. The longer the job lasts, the more important the daily cleaning.</p> <p>The "daily" procedures below apply to each work shift if the work is being done on more than one shift.</p> <p>Daily cleaning includes: (1) wrapping or bagging debris and storing same in a secure area; (2) vacuuming (using HEPA vacuums throughout) protective sheeting on floors and belongings; (3) vacuuming other horizontal surfaces within at least 6 feet of treated surfaces; (4) vacuuming and wet cleaning of floors used as passageways to the work areas (except that wet cleaning is not necessary if passageways can be reliably secured during non-work hours) any</p>	<p>NEARLY THE SAME AS FOR LOW-DUST JOBS, except that cleaning of horizontal surfaces should extend through the entire containment area, not just within 6 feet of the work surfaces.</p>

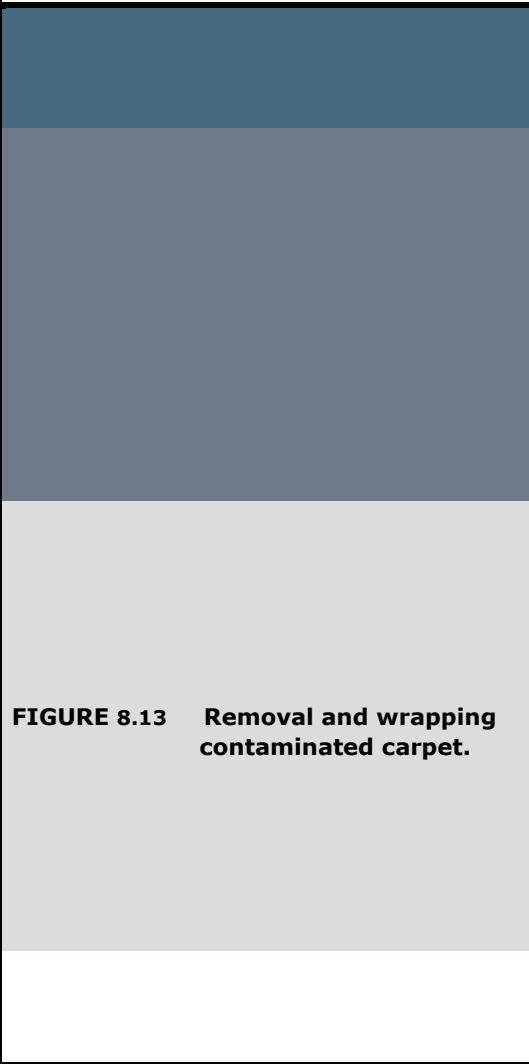
Description	Low-Dust Jobs	High-Dust Jobs (High-dust operations should be avoided if at all feasible.)
Cleanup (continued)	<p>areas used for storage of tools and debris; and (5) patching and repairing of protective sheeting and simple airlock flaps as needed.</p> <p>Contaminated objects need to be properly wrapped before removing from the work area (see Figure 8.13).</p> <p>Do not store dust, debris and other waste inside the dwelling overnight. Instead, transfer the waste to a locked secure area or container that prevents release of, and access to, dust and debris.</p> <p><b>Final cleanup:</b> The final cleanup includes: (1) cleaning and removal of protective sheeting from the floor and belongings and discarding of same; (2) vacuuming and wet cleaning all horizontal surfaces (including window troughs) within at least 6 feet in all directions of all disturbed painted surfaces (cleaning beyond the 6 feet perimeter is recommended as a safety precaution if dust generated by the work may have spread beyond 6 feet); (3) cleaning all window troughs; and (4) vacuuming and wet cleaning the floor in adjacent areas used as pathways to the work areas. See Chapter 14 for further guidance on cleaning before, during, and after hazard control and other paint-disturbing work.</p>	 <p><b>FIGURE 8.13</b> Removal and wrapping contaminated carpet.</p>
Monitoring Effectiveness of Containment	<p>The project supervisor must make sure that dust generated by paint-disturbing work has not spread beyond the containment area.</p> <p>Conduct visual monitoring while paint-disturbing work is underway and while workers are stepping off the protective sheeting on the work-area floor.</p> <p>Checking the quality of the effectiveness of containment is optional for low-dust jobs but is encouraged for low-dust jobs lasting longer than 5 consecutive days. (If the quality check is to be conducted, see the procedures for high-dust jobs.)</p>	<p>The project supervisor must make sure that dust generated by paint-disturbing work has not spread beyond the containment area.</p> <p>Conduct visual monitoring while paint-disturbing work is underway and while workers are stepping off the protective sheeting on the work-area floor.</p> <p>HUD recommends that the project supervisor (certified renovator) check the quality of the effectiveness of containment of high-dust jobs as follows:</p>

Description	Low-Dust Jobs	High-Dust Jobs (High-dust operations should be avoided if at all feasible.)
<p>Monitoring Effectiveness of Containment (continued)</p>		<ul style="list-style-type: none"> <li data-bbox="976 373 1482 861"> <p><b>+</b> For high-dust jobs scheduled to be in containment for up to 5 consecutive days:</p> <ul style="list-style-type: none"> <li data-bbox="1027 495 1409 558">— Supplement the project oversight with cleaning verification.</li> <li data-bbox="1027 590 1463 861">— Specifically, at the end of <i>each</i> work day (or work shift if the work is being done on more than one shift), perform the cleaning verification of the floor of the living area outside the containment that is at greatest risk of contamination (usually the living area closest to the work area).</li> </ul> </li> <li data-bbox="1049 892 1482 1087"> <p><b>+</b> It is essential that the cleaning verification be performed before daily cleaning to determine if the containment system was effective in protecting the occupants that day.</p> </li> <li data-bbox="976 1119 1463 1675"> <p><b>+</b> For high-dust jobs scheduled to be in containment for more than 5 consecutive days, or turns out to take that long:</p> <ul style="list-style-type: none"> <li data-bbox="1027 1278 1409 1341">— Supplement the project oversight with dust-wipe testing.</li> <li data-bbox="1027 1373 1463 1675">— Specifically, a dust-wipe sample should be collected at the end of <i>each</i> work day (or work shift if the work is being done on more than one shift) from the floor of the living area outside the containment that is at greatest risk of contamination (usually the living area closes to the work area).</li> </ul> </li> <li data-bbox="1008 1707 1482 1875"> <p><b>+</b> It is essential that the sample be collected <i>before</i> daily cleaning to determine if the containment system was effective in protecting the occupants that day, and</p> </li> </ul>

Description	Low-Dust Jobs	High-Dust Jobs (High-dust operations should be avoided if at all feasible.)
<p>Monitoring Effectiveness of Containment (continued)</p>		<p>that the location of the sample not be known in advance to the person(s) or firm(s) conducting the job.</p> <ul style="list-style-type: none"> <li>— Sampling, analysis and use of dust tests.</li> <li>+ Samples for this purpose should be collected by a certified risk assessor, lead-based paint inspector, or sampling technician. The wipe sample should be collected in accordance with Appendix 13.1, or similar protocol.</li> <li>+ Dust-wipe samples should be sent to a laboratory recognized for analysis of lead in dust by the National Lead Laboratory Accreditation Program (NLLAP) (or an EPA-authorized State/Tribal-required alternative). One-day service (or faster, if desired to expedite the project) should be ordered.</li> <li>+ Lead levels in the floor dust should be less than the applicable floor dust standard for clearance (the Federal standard as of the publication of this edition of these <i>Guidelines</i> is 40 µg of lead per square foot).</li> <li>+ If the dust-lead level is above clearance standards or if the cleaning is not verified, the person in charge should immediately:             <ul style="list-style-type: none"> <li>— Clean the areas represented by the failed clearance testing or cleaning verification.</li> </ul> </li> </ul>

Description	Low-Dust Jobs	High-Dust Jobs (High-dust operations should be avoided if at all feasible.)
<p>Monitoring Effectiveness of Containment (continued)</p>		<ul style="list-style-type: none"> <li>— Review all elements of the worksite preparation and occupant protection for the job, make improvements where feasible (e.g., repairing torn contaminant barriers), and reaffirm strict compliance by all workers with lead-safety procedures.</li> <li>— If dust-lead levels are found to exceed the clearance standard a second time, residents must be relocated and must not be allowed to reenter the dwelling until final cleanup and documented compliance with clearance standards or cleaning verification is achieved.</li> </ul> <p>□ If a work-crew supervisor (certified renovator) can document that the containment is effective (that is, for the area outside containment that was checked, the wipe sample is below the dust-lead clearance standard, or the area passed cleaning verification) for 3 or more consecutive dwelling units in which the work crew used the same hazard-control techniques on high-dust jobs, then the frequency of checking high-dust jobs can be reduced to 1 in every 10 dwelling units for that supervisor.</p>

### **C. Worksite Preparation for Exterior Paint-Disturbing Work**

For exterior paint-disturbing work, worksite preparation is dependent on several factors: the amount of dust created; how high up the work surfaces are; how near the work surfaces are to other properties; weather conditions; the location of the residents; and whether people must pass in and out of the building during the work. A porch, balcony, or deck is considered to be exterior, unless it is enclosed by screens or windows, in which case it is considered to be an interior room for the purpose of worksite preparation. Only one set of instructions is provided because the same approach is used for low-dust and high-dust exterior jobs.

#### **1. Resident Location**

Residents may remain inside dwellings outside of which exterior work is being done, but must be away from the work area for the duration of the exterior project until final cleanup and exterior clearance have been completed. Alternatively, residents may leave their dwellings during workdays and return to the interior (not the exterior work area) after daily cleanup at the end of each workday (presuming the work is done during just the day shift), or residents may temporarily relocate for the duration of the project. Remaining residents must have lead-safe access to entry/egress pathways. (For longer-duration HUD-assisted interior work, the Lead Safe Housing Rule (LSHR) requires that residents be relocated; see Section IV, Temporary Relocation, below, Appendix 6, and the LSHR at 24 CFR 35.1345(a)(2).)

Workers should tightly close or seal windows, doors, and other building openings within 20 feet of surfaces being disturbed during exterior work. Remaining residents should be instructed not to open windows within 20 feet of ongoing work. Daily cleanup of horizontal surfaces within 20 feet of disturbed surfaces is essential.

#### **2. Containment and Barrier System**

Place one layer of disposable impermeable plastic (not landscape fabric, geotextiles, or cloth) protective sheeting (typically at least 6 mil thick to resist tears) on the ground, weighted down by heavy objects, and extending far enough from the work surfaces to adequately collect all falling paint chips and debris. EPA's RRP rule requires that the sheeting extend at least 10 feet in all directions beyond working surfaces when work is on the ground floor, or a sufficient distance to collect falling paint debris, whichever is greater, if feasible; these criteria are also appropriate for abatement work. As a general guide, if work is above the ground floor, sheeting should extend 20 feet. These distances apply unless an adjacent building or other obstacle interferes (see Figure 8.14, and the following paragraph). Being up high and exposed to wind currents, dust created by scraping an exterior above the ground floor has the potential to contaminate a large area. Scaffolding with vertical shrouding or staging on pump jacks are other options. Vertical shrouding on scaffolding generally should be used if work is close to a sidewalk, street, or another property, or if work will be conducted at a height of more than three stories.

If an adjacent building, building wing, or property line is closer than the distance the sheeting should extend (10 feet or 20 feet, as applicable), provide as much protection as feasible. For example, if the adjacent building is on the same property as project building, or is owned by the same owner, protective sheeting should be placed on the facing side of the adjacent building within 10, or 20, feet of the work area, as described above.



**FIGURE 8.14** Exterior containment of polyethylene sheeting lines the narrow walkway between two houses. Notice the abatement worker in the background.

(See figure 8.14) If the adjacent building is owned by another owner, an effort should be made to coordinate with that owner to allow protective sheeting to be installed on that owner's ground and building.

Tape and/or staple protective sheeting to wood siding or ribbon board so there are no gaps between sheeting and building. A wood strip may have to be attached to a masonry wall. Build a curb at the edge of the protective sheeting to prevent contaminated runoff and reduce blowing of debris off the sheeting. If power washing is planned, extra care is needed to contain runoff. Weigh sheeting down with two-by-fours or similar objects. In hot weather, take care not to burn out vegetation under plastic sheeting. White plastic is less harmful than black or clear. Do not place ladder feet on top of plastic sheeting. Cut slots in the sheeting and place ladder feet on the ground and repair slots with tape when the ladder is moved. Alternatively, place a large, sturdy piece of plywood on the sheeting and put the ladder on the plywood (see Figure 8.15). If power washing is planned, a certified abatement supervisor with experience with such methods should design special containment and water-collection measures.



**FIGURE 8.15** Exterior containment on building and window; ladder kept on plywood.

Keep all windows, doors, and other building openings within 20 feet of working surfaces (including openings in adjacent buildings) tightly closed or sealed with protective sheeting unless entry to the interior is needed. If possible, require use of an alternative entryway for existing entryways closer than 20 feet. If an entrance must be used that is closer than 20 feet, place a shroud above and on the sides of the entrance and install a simple airlock flap at the door (see the Containment and Barrier Systems row of Table 8.1, above). In addition, install a tack pad inside the door so shoes can be cleaned off.

If residents are remaining in the dwellings or returning at the end of the day, at least one lead-safe entryway must be made available. Do not work on front and rear porches at the same time unless there is a third entry.

### 3. Playground Equipment, Toys, Sandbox, and Outdoor Furniture

Remove all movable items to at least a 20-foot distance from working surfaces. Items that cannot be readily moved to a 20-foot distance must be sealed with taped protective sheeting.

#### 4. Security

Erect temporary fencing or barrier tape at a 20-foot perimeter around working surfaces (or less if distance to the next building or sidewalk is less than 20 feet). If practical, require use of an alternative entryway for any entrance within 20 feet of working surfaces. If not, install a shroud, simple airlock flap, and tack pad, as described above. Use a locked metal bin, locked covered truck, or locked room to store debris securely before disposal.

#### 5. Warning Signs

Post warning signs on the building and at a 20-foot perimeter around the building (or less if distance to next building or sidewalk is less than 20 feet). Warning signs should be in a language understandable to residents (see Figures 8.10 and 8.11). Recommended wording is: “**Warning. Lead Work Area. Poison. No Smoking or Eating.**” Some states have specific sign requirements, and wording can be adapted as appropriate to project-specific conditions. See EPA’s RRP rule for sign requirements for renovations. You may also use barrier tape (see Figure 8.16).

If an employee’s exposure to lead is above the permissible exposure limit (PEL) of 50  $\mu\text{g}/\text{m}^3$  of airborne lead averaged over an 8-hour period, warning signs must be posted at in each work area. The mandatory language for these signs is shown in Chapter 9, Section III.

#### 6. Weather

Do not conduct exterior work if wind speeds are greater than 20 miles per hour or if dust and debris cannot be adequately contained. If chips and debris are blowing off the protective sheeting, work must stop until the wind dies down or adequate containment is installed. In the meantime, cleanup must occur before rain, snow or other precipitation begins.



**FIGURE 8.16** Example of barrier tape used as an occupant protection measure.

#### 7. Cleanup

Cleanup should be conducted at the end of each workday, the end of each work shift when work is being done on more than one shift, or when workers are finished in one exterior work area and moving to another, whichever is soonest.

- + Remove debris and paint chips and wet clean all horizontal surfaces on the building (e.g., exterior window sills and exposed window troughs, porches, balconies, railings) within 20 feet from working surfaces.
- + Remove debris and paint chips from the protective sheeting.

- + Dispose of water that has collected on the protective sheeting in accordance with local rules (usually flushing it down a toilet is acceptable, but do not dump it down a storm drain or a sink, tub, or shower).
- + Clean (either vacuum or wet clean) the protective sheeting.

After cleaning:

- + Fold protective sheeting inward to avoid contamination of the environment. Do not reuse protective sheeting.
- + Visually inspect for and remove any debris and paint chips from the ground, walkways, gardens, shrubbery, and play areas. Refer to Chapter 14 for further guidance on cleaning before, during, and after hazard control and other paint-disturbing work.
- + Do not leave debris or protective sheeting out overnight (or after the final work shift of the day).
- + Keep all debris, protective sheeting, and other disposable material in a secured area that will not allow release of the material, until final disposal. (See Section III.C.4, above.)

### D. Worksite Preparation for Windows

Because windows have both interior and exterior sides, workers should protect both interior and exterior spaces from contamination when repairing or replacing old windows or performing interim controls or abatement of lead-based paint hazards on

windows. Most window repair and window interim control work can be considered low-dust work if paint surfaces are misted before being scraped and prepared for repainting, and scored before removing small parts like stops and parting beads. However, if the entire window, including the jamb casing, stool, and apron, is being replaced, workers should prepare for high dust generation.

An important consideration in planning dust containment for window work is that the windows may be open during most of the work, creating the potential for wind-blown dust into the interior. Therefore, workers should follow the guidance given in Table 8.1 for interior worksite preparation that protects against wind-blown dust, if window openings are not closed, either by closing the storm window, if present and operable, or by covering the opening with protective sheeting (see Figure 8.17), or if the work is such that the window will not be opened, such as if it is for repair of paint on the underside of the interior sill (see Figure 5.14) or the face of the window frame.

If working on windows from the outside, it may be possible to tack or tape protective sheeting to the interior window casing or wall, completely covering the window opening, and achieve sufficient interior worksite protection. If the interior of the unit is adequately protected, the interior would not need to undergo a clearance examination. Care must be taken in preparation, because attaching sheeting to the interior wall may cause unacceptable damage to the wall surface unless appropriate tape, such as blue painter's tape, is used.



**FIGURE 8.17** Pre-cleaning window with HEPA vacuum.

If the window is not sealed to the interior of the unit before it is removed from the outside, interior cleanup and clearance would still be necessary. Also, exterior worksite preparation, as described in Section III.C, is always required for window removal from the outside, and the protective sheeting must be removed and disposed of with care.

Workers should follow other guidance provided in Table 8.1, above, for resident location, barriers, signs, security, ventilation system, furniture protection, weather, cleanup, and clearance.

If working from the inside and there is no operable storm window, workers may be able to tack and tape protective sheeting to the outside window surround or wall, completely covering the window opening, so that dust and debris will not fall on exterior surfaces other than the window sill. If there is an operable storm window, workers may either install the sheeting as described above, or put tape across the gaps between the storm window sashes and frame, and between storm window sashes. This will preclude the blowing of dust into the interior, and it will also provide adequate protection of the exterior so further exterior worksite preparation may not be necessary. (Of course, the protective sheeting must be removed and disposed of with care, and exterior cleanup and visual assessment for dust, debris and residue should still be done.) If this method is not used, the interior and preparation based on either low- or high-dust generation, as appropriate, and protecting against wind-blown air. As noted in Section III.B and Table 8.1, high-dust operations should be avoided if at all feasible; planning for window replacement projects should include sufficiently stringent precautions and controls to minimize the likelihood of the project becoming a high-dust project.

### **E. Worksite Preparation for Soil-Lead Hazard Controls**

Disturbing lead-contaminated soil poses the risk of generating dust that can contaminate building surfaces, both interior and exterior, and adjacent yard and paved areas. The most effective way to reduce dust generation is to continually dampen the soil as it is being disturbed. This should always be done. However, workers should take care not to over-water the soil. Excessive dampening of the soil is likely to cause runoff and require the use of major curbing methods, such as bales of hay.

If the soil-lead hazard control method being used involves minimal disturbance of the bare soil (as may be the case when the soil is covered with bark, mulch, sod, gravel, landscaping fabric, paving stones, or asphalt paving) and if the soil is kept damp during the work, adequate worksite preparation is to place protective sheeting on ground surfaces, porches, etc. within at least 6 feet of the work area on all sides and to tightly close or seal all building openings within at least 10 feet. These distances are minimum guidance. Supervisors should visually monitor dust spread and adjust the containment if needed during a particular project.

If, however, the soil is being shoveled, cultivated, rototilled, or otherwise subjected to major disturbance, protective sheeting on the ground should extend at least 10 feet from the soil, and all building openings within 20 feet of the work area should be tightly closed or sealed. Of course, this should be accompanied by periodic dampening of the soil during the work.

Perform daily and final cleanup. Follow the cleanup guidance for exterior paint-disturbing work (see Section III.C.7, above), except, of course, references to paint chips apply only if the soil was visibly contaminated with them.

## **IV. Temporary Relocation**

Temporary relocation means that occupants currently living in a dwelling intend to return to that unit once the work is finished. There are many possible variations – from requesting residents to vacate the unit for just one workday (leaving their belongings in the unit and returning at the end of the day) to moving everything out for several weeks or months. Temporary relocation of residents can be disruptive, complicated, and costly. Careful planning of relocation pays off in good client relationships, cost containment, and efficiency in conducting the work. This section provides answers to some of the most common questions about relocation.

### **A. When Is Relocation Necessary and What Are the Options?**

Temporary relocation of residents is generally recommended when work is undertaken that will disturb painted surfaces known or suspected to contain lead-based paint and the work will occur throughout much of the dwelling over several days. (If the work does not disturb lead-based paint, dust-lead hazards or soil-lead hazards, relocation is usually not necessary as a lead-exposure protection measure.) Temporary relocation is clearly necessary if residents cannot have safe access to bathrooms, sleeping areas, and kitchen facilities (or alternative eating arrangements) during non-work hours.

Safe access includes the absence of other significant safety, health, or environmental hazards in addition to lead hazards (e.g., toxic fumes, on-site disposal of hazardous waste, or exposed electrical wiring).

There are, however, several exceptions and options that may be considered in deciding whether it is necessary for residents to temporarily relocate and, if so, for how long and whether furniture and other belongings must be moved.

#### **1. Work Is a Small Area**

If only a small amount of paint is being disturbed, that is, an amount below HUD's *de minimis* threshold for HUD-assisted projects, or EPA's minor repair and maintenance work threshold for unassisted projects, special measures to protect residents from exposure to leaded dust are not required (see Section II.A, above, for a definition of the HUD and EPA area threshold definitions). However, basic precautions are strongly recommended. These include: never using prohibited paint-removal practices (see Chapter 11, Section II.D.1), and cleaning the work area thoroughly after work is completed. Also, if a child under age 6 resides in or accesses the unit or area, keep residents out of the work area until after final cleanup.

#### **2. Work Is Only on the Outside**

Residents and their belongings may remain inside the dwelling if the work is only on the exterior and building openings (windows, doors, vents) within 20 feet of disturbed paint surfaces are tightly closed or sealed and cleaned afterward, *and* an entryway is provided that is free of dust-lead hazards, soil-lead hazards, and debris.

#### **3. Work and Clearance Take Only One Day**

If the work, final cleanup, and clearance can be achieved (i.e., results of dust sampling received from the laboratory and found to be acceptable) in one work day, residents need to be out of

the work area or the unit only for that day and can return with full access to the unit at the end of the day. As a practical matter, however, completion of the work and achievement of clearance in one day may not be a realistic goal. It usually takes an additional day to get the results of the laboratory analysis. However, as discussed in Unit IV.E, below, methods (including portable X-ray fluorescence (XRF) analysis and anodic stripping voltammetry) exist for reliably analyzing wipe samples on-site instead of in a fixed laboratory, which may provide testing results much more quickly than fixed-laboratory analysis by avoiding transportation of the samples to the laboratory and handling time within the laboratory. A laboratory that is recognized under NLLAP for mobile source lead dust analysis may be used for clearance. This approach may be particularly helpful for multi-family projects, in which a work crew may be working on a unit while the clearance test analysis is being performed on the crew's preceding unit. Sometimes work areas do not pass clearance the first time, so recleaning and additional dust sampling is required, which may require an additional day, even if the dust-lead analysis is rapid.

#### 4. Work Area Is Limited and Work Is of Short Duration

Relocation is usually not necessary or is necessary only for workday hours if the work: takes less than five days; is being conducted in only one or two rooms; and if exclusion from those rooms does not preclude safe resident ingress and egress to the unit and safe access to kitchen (or alternative eating arrangements), bathroom, and sleeping areas. Furniture and other belongings can be moved out of the workrooms, or covered and sealed with protective sheeting and tape. It is recommended, however, that residents who remain in their units or vacate only during workday hours while such limited area work is being conducted be required to sign a statement that: (1) they understand that there may be lead-based paint hazards in both specified work areas and traffic areas used by workers outside the work areas in spite of a thorough cleaning of such areas; and (2) they agree not to enter the work areas until they are notified by a specified responsible party that the areas have passed clearance (or cleaning verification, if applicable).

Theoretically, such arrangements, in which residents remain in the unit or are absent during the workday but return for the night, can continue for an extended period of time. As a practical matter, however, there are limits to how long people will comply with such procedures. HUD regulations pertaining to housing receiving Federal assistance for the residents to live there or for the work allow this type of arrangement to continue for no more than five calendar days (24 CFR 35.1345(a)(2)(iv)). If residents are to be allowed back in the unit during the night, it is necessary that workers thoroughly clean, at the end of each work day, not only the work areas but also the floors of the pathways used by workers to and from the work areas. Installing protective sheeting on these pathways facilitates cleaning. If a decontamination area is used in a large multi-family project, cleaning is necessary only from the work areas to the decontamination area.

#### 5. Exception for Elderly Residents

Because of the added difficulties that may accompany the relocation of elderly residents, it is acceptable to make special exceptions to normal relocation policy for them. This exception is acceptable for work to be done in housing for the elderly. (As stated in the Lead Safe Housing Rule, housing for the elderly means retirement communities or similar types of housing reserved for households composed of one or more persons 62 years of age or more, or other age if recognized as elderly by a specific Federal housing assistance program; it is not merely housing occupied by the elderly.) If elderly residents are permitted to stay in their units when temporary relocation would normally be required, they should be fully informed about

the nature of the work and the hazards that may be generated; they should be required to sign an informed consent form before the work begins; and, of course, children should not be permitted in the unit. If the resident declines to sign, the property owner and the contractor will have to determine whether or not the job will be performed. Figure 8.18 is an example of an informed consent form. No such policy or form should be implemented without advice from the contractor's legal counsel.

**Figure 8.18 Sample Informed Consent Form for Residents of Housing for the Elderly.**

I/We, the undersigned,

choose to remain in my/our home while \_\_\_\_\_  
(Description of work)  
 is being performed;

*or*

choose to relocate to another unit while the work is being performed;

*and*

I/We have made this choice having read and understood the following:

1. I am/At least one of us is at least 62 years old.
2. My/Our home was built before 1978 and is housing designated for the elderly.
3. I/We have received the pamphlet "*Protect Your Family From Lead in Your Home*" and the pamphlet "*Renovate Right: Important Lead Hazard Information for Families, Child Care Providers and Schools*" ("*Renovate Right*"), and am/are aware of the health hazards that are posed by lead-based paint in general and that can be created by renovation, painting, repair or lead abatement work
4. I/We have been given a description of work that will be done in my/our home and understand that during the course of the work, lead hazards may be created in the work area. These hazards will be taken care of before the job is considered complete.
5. I/We may stay in my/our home but I/we may not enter the work area while work is being performed.
6. I/We will not allow children under age six or women of childbearing age to visit or reside in my/our home while work is being done, because visiting or residing may pose a health risk.
7. I/We waive rights to all damages. I/We agree to hold harmless

\_\_\_\_\_  
(The housing owner, public housing agency, or other responsible party)

for any damages due to lead poisoning that occur as a result of the work on these premises.

\_\_\_\_\_  
 Name                                      Date                                      Name                                      Date

## **B. What Relocation Units Are Acceptable?**

Relocation dwellings should be acceptable to residents so that they will not attempt to return to their own dwellings during paint-disturbing work. Generally, dwellings serving as temporary relocation units should, at minimum, meet applicable housing codes. If they are HUD-assisted, they should meet the regulatory standards, e.g., housing quality standards (24 CFR 982.401) or physical condition standards (24 CFR 5.703). If they were constructed before 1978 and are not HUD-assisted, they should also pass a visual assessment; that is, they should have no deteriorated paint and no visible dust or debris. If a dwelling constructed before 1978 is to be occupied by a relocated household for more than 100 days or if it is used repeatedly for temporary relocation (such as a lead-safe unit operated by a community program) with occupancy periods totaling more than 100 days, it should be found to be lead-safe by a risk assessor before the first occupancy begins, and at least annually thereafter. In addition, these units should be adequately equipped with furniture, cooking facilities, refrigerators, televisions, and toys (except for items that will be moved with the residents). Relocation is usually a substantial undertaking, involving not only the movement of people and their possessions, but also the coordination of mail, phone, school, and community changes. Whenever possible, children should continue to attend the same school during the relocation period, even though this may involve finding special transportation. Due to their complex nature, relocation considerations may dictate the scheduling of the project. Destination options include staying with relatives or friends, a designated relocation unit owned or leased by a local organization, a hotel or motel (usually the most costly and least desirable option for families with children), or a temporarily vacant unit in the same multi-family property. If the Lead Safe Housing Rule requires relocation of the family to a temporary unit during work, the unit to which the family is relocated must not have lead-based paint hazards (24 CFR 35.1345(a)(2)).

## **C. Allowing Reoccupancy after Interim Clearance**

In some rehabilitation jobs, it may be efficient to conduct all lead hazard control or abatement work first, using qualified firms and workers, and then, following a preliminary or "interim" clearance (see Chapter 15 for details), conduct other rehabilitation work that will not affect lead-based painted surfaces with firms or workers who are not certified for lead hazard control work or renovation work that may affect lead-based painted surfaces. Clearance is conducted after the hazard control or abatement work to document that the contractor has completed the job correctly. This clearance is sometimes called "interim clearance." The question may arise in such cases whether temporarily relocated residents can return after interim clearance is achieved but before all rehabilitation is finished. The general answer depends on the nature of the post-clearance rehabilitation work and how much dust will be created. Additional guidance is provided below. However, for units controlled under HUD's Lead Hazard Control grant program, and some local regulations, units in which rehabilitation work occurs following lead hazard control must pass a final clearance prior to re-occupancy by the residents (see the HUD Office of Healthy Homes and Lead Hazard Control's Policy Guidance 99-01, posted at: [http://portal.hud.gov/hudportal/HUD?mode=dispage&id=POLICY\\_GUIDANCES](http://portal.hud.gov/hudportal/HUD?mode=dispage&id=POLICY_GUIDANCES)).

Most rehabilitation activities generate a lot of dust. In old houses, such dust may be contaminated with lead even if the components being disturbed are not coated with paint that is considered lead-based paint under Government regulations. There are two reasons for this: (1) existing paint that is not lead-based paint can still contain lead; (2) dust under or behind floors or walls can be contaminated from accumulations that are decades old. Therefore, in old homes that have been found to contain lead-based paint hazards, it is recommended that there be a final clearance after all paint-disturbing work is

finished, even if there was an interim clearance previously and the follow-up work did not disturb lead-based painted surfaces. For this reason, it is recommended that relocated residents usually not return until after all paint-disturbing work is completed and final clearance is achieved.

If, however, the paint-disturbing work performed after interim clearance will disturb less than a *de minimis* amount of paint (see Section II.A, above), final clearance is not necessary and residents can return after the interim clearance. If the paint being disturbed exceeds the *de minimis* but is known not to be lead-based paint, residents can return. But in each case, i.e., if the *de minimis* applies or if the paint is not classified as lead-based paint, the precautions listed at the end of Section II.A, above, should be followed when disturbing paint in pre-1978 housing, unless it is known that all layers of disturbed paint have been applied after 1977: (1) never use the prohibited methods of paint removal that are described in Section III.C.1 of Chapter 6, or Section II.D of Chapter 11, and (2) when disturbing paint *in housing occupied by children of less than 6 years of age*, clean the work area thoroughly after finishing, preferably with a HEPA vacuum and wet cleaning, and always keep residents out of the work area while work is underway and until after the unit has passed clearance.

The approach above also applies to work that is not being cleared but is having its cleaning verified, that is, the work is covered by EPA's RRP Rule but not HUD's Lead Safe Housing Rule, and the paint-disturbing work performed after interim cleaning verification has been passed will be a minor repair and maintenance activity.

#### **D. Who Should Pay?**

If relocation of tenants is required as a result of an activity assisted by the Federal Government, the requirements of the Uniform Relocation Act (formally, the Uniform Relocation Assistance and Real Property Acquisition Policies Act of 1970 (42 U.S.C. § 4601 et seq.) and its implementing regulations at 49 CFR Part 24, may be triggered (see [www.hud.gov/offices/cpd/library/relocation/index.cfm](http://www.hud.gov/offices/cpd/library/relocation/index.cfm)). Relocation is usually considered to be part of the cost of lead hazard control.

#### **E. How Can Costs Be Minimized?**

One approach to minimizing relocation costs is to reduce the time period of temporary relocation. It may be possible to streamline the work so it proceeds quickly, especially if contractors are offered financial incentives to do so. Also, in some circumstances, it may be possible to stage the work, as discussed above, so residents can return before nonhazardous renovation is finished.

Another approach is to minimize specific relocation costs by taking competitive bids or negotiating favorable rates for rental units for relocation, and costs of packing, moving, and storage. Prices should be based on actual expenses, however, not on a per-dwelling-unit rate.

Some local program administrators have found that the most cost-effective approach is to give residents a direct dollar payment to find another place to live temporarily. Beware, however, that if the work takes longer than expected and thus the residents' costs are higher than was planned, people may return to the unit before it is ready. This approach may work in conjunction with temporary relocation to a relative's or friend's home.

Still another approach is to try to move most of the residents only once, rather than both out and back in. This permanent relocation can work with multi-building projects in which residents of the first building are relocated, work is performed in that building, and then residents of the

next building are permanently relocated to the first building, and so on. Variations on this include residents moving from one floor to another, from one wing of a building to another, etc. Some residents may like this; some may not. For projects receiving federal assistance for the housing or the work, such permanent relocation may trigger requirements of the Uniform Relocation Act; see Section IV.D. Open communication with residents about the project and the owner's approach to lead safety may help in addressing concerns about relocation.

Finally, on-site dust testing may save time and money. Methods exist for reliably analyzing wipe samples on-site instead of in a fixed laboratory. These include portable X-ray fluorescence (XRF) analysis and anodic stripping voltammetry (ASV) (EPA, 2002b; Clark, 2002). These methods may provide testing results much more quickly than fixed-laboratory analysis by avoiding transportation of the samples to the laboratory and handling time within the laboratory. This approach may be particularly helpful for multi-family projects, in which a work crew may be working on a unit while the clearance test analysis is being performed on the crew's preceding unit. Thus they may reduce relocation difficulties and facilitate cooperation among all parties.

In States and Tribal areas where EPA is operating the lead risk assessment certification program, dust wipe samples for a clearance examination must be analyzed by a laboratory or testing firm recognized by EPA under the National Lead Laboratory Accreditation Program (NLLAP). In these States or Tribes, an NLLAP laboratory may perform on-site analyses of dust-wipe samples only if specifically accredited and NLLAP-recognized to do so. In States or Tribal lands where the State or Tribe is operating an EPA-authorized lead program, the same requirements generally apply, although there may be some differences (EPA, 2002a). While EPA clearance regulations and program procedures apply only to abatement activities and to renovations in which clearance is being conducted, HUD regulations and many State regulations apply the same procedures to non-abatement activities.

However, any person who is trained and otherwise qualified to operate the XRF instrument (such as licensed in accordance with State regulations on the use of devices with radioactive elements) or conduct the ASV (or other sampling and analytical) method may use one of these methods to conduct *preliminary* dust testing to determine whether a clearance area is clean and ready for the clearance examination, if allowed in the State or Tribal area. A person conducting a preliminary screen does not have to be a technician working for an NLLAP-recognized laboratory. Owners and contractors may wish to use such screening tests to minimize the likelihood of clearance failure. (See Chapter 15, Section VI.A.3, "On-Site Clearance.")

## **F. Communicating with Residents**

Clear and documented communication with residents about the many details of relocation will facilitate a smoothly operating program. Administering organizations should establish policies, procedures, and assigned responsibilities to maximize efficiency of temporary relocation and assure that all program participants are treated in a consistent manner. Among the subjects that should be covered with residents are:

- + The need for and importance of temporarily relocating to protect the health of residents and their children.
- + The fact that residents must stay out of the work areas until permitted to return, and how that permission will be handled.
- + Approximately how long the relocation will last, and how delays in allowing residents to return to their dwellings will be handled.

- + The standards for the relocation unit, who is responsible for identifying it, and how that will be done.
- + Detailed procedures for handling relocation, including such matters as packing, moving, storage, and caring for personal belongings, utilities, mail, security of the temporarily vacant unit, care for pets, and any special transportation needs (such as to and from school).
- + What costs will be paid by the administering organization, limits on certain costs, and method of payment.
- + The residents' responsibility not to damage the relocation unit.

It is recommended that policies and procedures on these matters be put in writing and that residents indicate their agreement by signing such documents. These policies and procedures should be made available to meet the needs of all residents including persons with limited English proficiency.

## **V. Negative Pressure Zones (“Negative Air” Machines)**

In asbestos abatement work and lead-based paint removal work on structural steel, it is common to create worksites that are under negative pressure in comparison to the outside of the containment structure. A negative pressure zone is usually created by blowing air out of the work area through a HEPA filter, while air intake is restricted to a lower flow rate than the exhaust. This process causes any air leakage to move *into* the containment area instead of *out* of the containment area. It also reduces dust fall and worker exposure by removing contaminants from the airstream through constant filtration.

Under OSHA's lead in construction standard, a “competent person” determines the appropriate ventilation controls, considering such factors as the safety of workers, occupancy of adjacent areas, whether exterior windows are available to provide dilution ventilation, or if negative air is more appropriate where scraping of surfaces treated with paint strippers may potentially release both volatile substances and lead simultaneously. The standard says that a competent person is a person capable of identifying existing and predictable lead hazards in the surroundings or working conditions, who has authorization to take prompt corrective measures to eliminate them, and who makes frequent and regular inspections of job sites, materials, and equipment as part of a program to ensure that workers are not exposed to excessive levels of airborne lead. (29 CFR 1926.62, paragraphs (b), (c), (e)(2), and (e)(2)(iii) . For further information about competent persons, see OSHA's Competent Person page, <https://www.osha.gov/SLTC/competentperson/>.)

Due to the different aerodynamics of dust particles from leaded and asbestos fibers, negative pressure zones do not appear to be necessary for most forms of residential paint-disturbing work. Most lead-based paint abatement projects in the public housing program have not found it necessary to use negative air machines. However, there are two specific situations where the use of a negative pressure zone would be appropriate in a residential setting.

The first case involves floor sanding. Even if the lead-based paint or lead-containing varnish has already been removed, leaded dust generation is likely to be quite high due to residual dust in the flooring. Enclosing old flooring with new flooring is the recommended course of action. However, if old flooring must be restored, then negative pressure zones should be established. Up to 10 air changes per hour should be provided and all exhaust air must be passed through a HEPA filter.

If the floor to be sanded has been coated with varnish with low lead levels, negative air may not be necessary. One study has found that tight dust containment of the work area before the work, using engineering controls during sanding and careful cleanup afterwards can reduce worker exposure to dust and facilitate clearance of the worksite. The engineering controls used in this study included using HEPA vacuum exhaust attachments on sanding tools such as edgers and buffers and using drywall dust bags inside the canvas bags of drum floor sanding machines (Wisconsin, 2003).

The second case involves abrasive blasting, which is likely to produce extremely high levels of airborne leaded dust (NIOSH, 1992b) and should not be permitted in housing since other methods are readily available. One report indicated that the exterior sandblasting of a school resulted in 27,100 µg/g of lead in the soil at a nearby residence, and nearly 100,000 µg/g in the soil at the school (Peace, 1983). If for some reason abrasive blasting without local exhaust ventilation is performed on the interior of a dwelling, a full containment structure with HEPA filtration and adequate airflow should be required. Such a containment system would also be necessary if the exterior of a dwelling were blasted, usually resulting in "tenting" an entire building (i.e., erecting a temporary tent-like structure around a building or one face of a building). This setup may also be necessary in cases of major demolition where wet work practices cannot be used to adequately dampen dust.

For nearly all types of paint-disturbing work, windows should be kept closed to prevent dust and chips from leaving the unit. If volatile chemicals will be used, adequate ventilation must be provided, either by opening windows during the use of the chemicals or by supplying air through a HEPA air-handling machine.

# References

- California Department of Health Services, 2004. Public Health Institute for California Department of Health Services, Childhood Lead Poisoning Prevention Branch and Environmental Health Laboratory Branch, "Evaluation of Household Vacuum Cleaners in the Removal of Settled Lead Dust from Hard Surface Floors," Final Report to U.S. Department of Housing and Urban Development, 2004.
- Clark, 2002. Clark, C.S., "Development of a Rapid On-Site Method for the Analysis of Dust Wipes Using Field Portable X-Ray Fluorescence," prepared for the U.S. Department of Housing and Urban Development, January 2002.
- CMHC, 1992. Canada Mortgage and Housing Corporation, Saskatchewan Research Council Report, *Effectiveness of Cleanup Techniques for Leaded Paint Dust*, Saskatoon, Saskatchewan, Canada (also see Figley, 1994).
- EPA, 2002a. U.S. Environmental Protection Agency, "Questions & Answers About ETV Reports on Portable Technologies for Measuring Lead in Dust," December [2002. www.epa.gov/lead/pubs/etv.htm](http://www.epa.gov/lead/pubs/etv.htm)
- EPA, 2002b. U.S. Environmental Protection Agency, The Environmental Technology Verification Program (ETV), Verification Statements EPA-VS-SCM-50, 51, 52, 53 and 54. Prepared by Oak Ridge National Laboratory, Oak Ridge, Tennessee, August [2002. www.epa.gov/etv/pubs/02\\_vs\\_pal\\_sa\\_5000.pdf](http://www.epa.gov/etv/pubs/02_vs_pal_sa_5000.pdf), [www.epa.gov/etv/pubs/02\\_vs\\_niton\\_300.pdf](http://www.epa.gov/etv/pubs/02_vs_niton_300.pdf)
- Figley, 1994. Figley, D., and Makohon, J., "Effectiveness of Clean-Up Techniques for Leaded Paint Dust," Saskatoon, Saskatchewan: Saskatchewan Research Council, revised report SRC I-4800-38-C-92 to Canada Mortgage and Housing Corporation (originally published in 1992).
- HUD, 2001. U.S. Department of Housing and Urban Development, *Lead Paint Safety: A Field Guide for Painting, Home Maintenance, and Renovation Work*, March 2001 (HUD-1779-LHC). [www.hud.gov/offices/lead/training/LBPguide.pdf](http://www.hud.gov/offices/lead/training/LBPguide.pdf)
- HUD, 2004. U.S. Department of Housing and Urban Development, "Interpretive Guidance on HUD's Lead Safe Housing Rule: The HUD Regulation on Controlling Lead-Based Paint Hazards in Housing Receiving Federal Assistance and Federally Owned Housing Being Sold," Revised June 21, [2004. www.hud.gov/offices/lead/library/enforcement/LSHRGuidance21June04.pdf](http://www.hud.gov/offices/lead/library/enforcement/LSHRGuidance21June04.pdf)
- NIOSH, 1992b. National Institute for Occupational Safety and Health, *NIOSH Alert: Request for Assistance in Preventing Lead Poisoning in Construction Workers*, Revised Edition, U.S. Department of Health and Human Services, DHHS (NIOSH) Publication No. 91-116a, April 1992, pp. 1-21.
- NIOSH, 1993a. National Institute for Occupational Safety and Health, Personal communication by Leroy Mickelson on air sampling data for a lead-based paint abatement project on structural steel.
- Peace, 1983. Peace, B. and C.S. Clark, *Removal of Lead-Based Paint From Buildings as a Source of Urban Soil and Dust Contamination*, Annual Report, Center for the Study of the Human Environment, Institute of Environmental Health, University of Cincinnati, May 31, 1983.

Rich, 2002. Rich, David Q., G.G. Rhoads, L. Yiin, J. Zhang, Z. Bai, J.L. Adgate, P.J. Ashley and P.L. Liroy, "Comparison of Home Lead Dust Reduction Techniques on Hard Surfaces: The New Jersey Assessment of Cleaning Techniques Trial," *Environmental Health Perspectives*, 110(9): 889-893, September 2002. <http://www.ncbi.nlm.nih.gov/pmc/articles/PMC1240988/>

Wisconsin, 2003. Wisconsin Division of Public Health, Ikens, Hardwood Floors, J. Schirmer, J. Havlena, and R. Ikens, "Is There Lead in Varnish?," Presentation at Wisconsin Environmental Health Conference, 2003.

Yiin, 2002. Yiin, Lih-Ming, F.F. Rhoads, D.Q. Rich, J. Zhang, Z. Bai, J.L. Adgate, P.J. Ashley and P.J. Liroy, "Comparison of Techniques to Reduce Residential Lead Dust on Carpet and Upholstery: The New Jersey Assessment of Cleaning Techniques Trial," *Environmental Health Perspectives*, 110(12): 1-5, December, 2002. <http://ehp03.niehs.nih.gov/article/fechArticle.action?articleURI=info%3Adoi%2F10.1289%2Fehp.021101233>

# **SECTION 5**

## **Model Written OSHA Safety Plan**

### **TDEC DSWM Rule 0400-13-01-.01 (6)**

Work Practice Standards for Conducting Lead-Based Paint  
Activities: Target Housing and Child-Occupied Facilities

# EXAMPLE

## Model Written OSHA Safety Plan

**Submittal Date:** \_\_\_\_/\_\_\_\_/\_\_\_\_

This plan has been developed to comply with the Rule Chapter 1200-1-18 (8) Work Practice Standards for Conducting Lead-Based Pint Activities: Target Housing and Child-Occupied Facilities and the OSHA Construction Lead Standard, 29 CFR 1926.62.

### 1. Location of Project:

This job will take place at the residence located at \_\_\_\_\_  
(full address, city and state).

A previous lead inspection of this residence was conducted by \_\_\_\_\_  
(name and address of inspection or risk assessment firm) revealed that lead hazards or lead-based paint are present in the following locations:

**Table 1  
(Results of the Lead Inspection Report)**

Location Co	mponent	Lead-Based Paint	Lead Hazard
Living Room	Door Frame	Present	Yes

These building components are coated with lead-based paint and represent a hazard to workers who may disturb it during lead hazard control, renovation, or maintenance activities.

### 2. Brief Description of Job:

This job (name all task to be completed) will involve the following lead hazard reduction measures:

Replacement of \_\_\_\_\_  
Enclosure of \_\_\_\_\_  
Paint removal of \_\_\_\_\_  
Encapsulation of \_\_\_\_\_  
Paint film stabilization \_\_\_\_\_  
Friction surface treatments of \_\_\_\_\_  
Impact surfaces treatments of \_\_\_\_\_  
Dust removal in the following areas \_\_\_\_\_

### 3. Schedule:

The job is expected to start on \_\_\_\_M/D/Y\_\_\_\_ and end on \_\_\_\_M/D/Y\_\_\_\_.  
This compliance plan will take effect immediately on \_\_\_\_M/D/Y\_\_\_\_.

The competent person will conduct worksite visual inspections on a daily basis.

Work will proceed according to the following schedule:

Day 1: Initial setup, followed by:  
(Name all tasks to be completed)

Daily clean up: wet mopping, HEPA vacuuming

Day 2: Tasks

Day 3: Tasks

Day 4: Final cleanup and clearance examination

#### 4. Equipment and Materials:

List the equipment

#### 5. Certified Work Crew:

The work will be completed by a certified work crew of \_\_\_\_\_ workers (list all workers).

Table 2

Certified Individual	Discipline	TN Certification Number
John Abatement	Worker	TNLBP-0000-00W

#### 6. Competent Person

**Certified Supervisor's Name:** \_\_\_\_\_

**Certified Supervisor's Number:** \_\_\_\_\_

**Business Address:** \_\_\_\_\_

**Telephone #:** \_\_\_\_\_ **Pager:** \_\_\_\_\_

A certified supervisor is required for each abatement project and shall be onsite during all work site preparation and during the post-abatement cleanup of work areas. At all other times when abatement activities are being conducted, the certified supervisor shall be onsite or available by telephone, pager or answering service and able to be present at the work site in no more than two (2) hours.

The certified supervisor will conduct daily inspections of the work areas to ensure that the certified abatement worker(s) are using the control measures, work practice standards, personal protective equipment, and hygiene facilities as prescribed in this document.

**7. Control Measures:**

The primary control methods for the project are:

- \_\_\_\_\_ method substitution (building component replacement, enclosure)
- \_\_\_\_\_ wet methods
- \_\_\_\_\_ wrapping materials to be discarded in plastic
- \_\_\_\_\_ respiratory protection
- \_\_\_\_\_ local exhaust ventilation (needle guns, vacuum blasting)
- \_\_\_\_\_ general room ventilation
- \_\_\_\_\_ on-the-job training
- \_\_\_\_\_ HEPA vacuums
- \_\_\_\_\_ containment (use of plastic barriers)

**8. Technology Considered in Meeting the Permissible Exposure Limit:**

**9. Respirators:**

All individuals in the work area will be provided with NIOSH / MSHA –approved half-face, air-Purifying respirators equipped with HEPA cartridges or a powered air-purifying respirator (if so Requested.)

Respirators will be provided in the context of a complete respiratory protection program; the Written respirator program is attached.

Respirators will be required during (name phases of job or task to be performed for which respirators will be required):

\_\_\_\_\_  
\_\_\_\_\_  
\_\_\_\_\_

Respirator use during other activities, including initial setup (laying down plastic for containment), and enclosure and encapsulation after surface preparation is not necessary, unless other workers nearby (same interior room or outside wall are performing activities for which respirators are required).

**10. Protective Clothing:**

Disposable protective clothing will be worn at all times inside the work area. Protective clothing will be made of breathable fabric to reduce the potential for worker heat stress. If visibly contaminated with dust or paint chips, protective clothing will be vacuumed before it is removed.

**11. Hygiene Facilities:**

Hand-washing facilities will be used to decontaminated workers, since lead dust levels are expected to be low.

Showers are used on jobs that generate high leaded dust levels.

The facilities will be located in a portable trailer, which will be parked in the driveway of the residence. The trailer will contain two sinks, a fresh water tank, hot water heater, wastewater collection tank, and easily cleanable floors and benches. Labeled plastic bins with covers will be used to separate disposable protective clothing from street clothing. Hot water, soap, and towels will be provided. Hands and face will be washed before all breaks and at the end of the day.

Wastewater will be collected, pretreated onsite with filtration, and disposed of in accordance with arrangements made with \_\_\_\_\_ (name of the local water and sewage authority).

**12. Air Monitoring Data:**

Previous data (historical) for lead hazard control projects conducted with similar controls, environmental conditions, personnel, and methods were reviewed. Air sampling will not be performed on this job, since typical exposures have already been established for individuals performing similar job task(s):

\_\_\_\_\_  
\_\_\_\_\_

(List when, name of task during which substantial exposures are likely to occur).

In previous work conducted by the same contractor and work crew on similar houses in the same city, using the same methods, maximum personal exposures measured for various activities were:

**Table 3**

Maximum Exposure	Job Performed (Task)

**29 CFR 1926.62, Lead Exposure In Construction; Interim Final Rule--Inspection and Compliance Procedures**

The employer may elect to provide a written plan that is unique to each worksite, but this is not required as long as the elements required by 29 CFR 1926.62(e)(2)(ii)(A)-(I) are specific to the conditions at the job site.

# **Rule 0400-13-01-.01(6)**

## **LEAD-BASED PAINT ABATEMENT**

### **Work Practice Standards for Conducting Lead-Based Paint Activities: Target Housing and Child-Occupied Facilities**

- (6) Work Practice Standards for Conducting Lead-Based Paint Activities: Target Housing and Child- Occupied Facilities.
- (a) Applicability and Terms.
1. All lead-based paint activities shall be performed pursuant to the work practice standards contained in this paragraph.
  2. When performing any lead-based paint activity described by the certified individual as an inspection, lead-hazard screen, risk assessment, project design, or abatement, a certified individual must perform that activity in compliance with the appropriate requirements of this paragraph.
  3. Documented methodologies that are appropriate for this paragraph are found in the following:
    - (i) The U.S. Department of Housing and Urban Development (HUD) Guidelines for the Evaluation and Control of Lead-Based Paint Hazards in Housing;
    - (ii) The EPA Guidance on Residential Lead-Based Paint, Lead-Contaminated Dust, and Lead-Contaminated Soil;
    - (iii) The EPA Residential Sampling for Lead: Protocols for Dust and Soil Sampling (EPA report number 7474-R-95-001);
    - (iv) Regulations, guidance, methods or protocols issued by states and Indian tribes that have been authorized by EPA;
    - (v) The Enterprise Foundation, Housing Developer Pro specification computer software package; and
    - (vi) Other equivalent methods and guidelines.

4. Clearance levels that are appropriate for the purposes of this paragraph may be found in subpart (f)9(viii) of this paragraph.
- (b) Inspection.
1. An inspection shall be conducted only by a person certified by the Commissioner as an inspector or risk assessor and, if conducted, must be conducted according to the procedures of this subparagraph.
  2. When conducting an inspection, the following locations shall be selected according to documented methodologies and tested for the presence of lead-based paint:
    - (i) In a residential dwelling and child-occupied facility, each component with a distinct painting history and each exterior component with a distinct painting history shall be tested for lead-based paint, except those components that the inspector or risk assessor determines to have been replaced after 1978 or to not contain lead-based paint; and
    - (ii) In a multi-family dwelling or child-occupied facility, each component with a distinct painting history in every common area, except those components that the inspector or risk assessor determines to have been replaced after 1978 or to not contain lead-based paint.
  3. Paint shall be sampled in the following manner:
    - (i) The analysis of paint to determine the presence of lead shall be conducted using documented methodologies that incorporate adequate quality control procedures; and
    - (ii) All collected paint chip samples shall be analyzed according to subparagraph (g) of this paragraph to determine if they contain detectable levels of lead that can be quantified numerically.
  4. The certified inspector or risk assessor shall prepare an inspection report and comply with the project review acknowledgement required in part (k)1 of this paragraph. The inspection report shall include the following information:
    - (i) Date of each inspection;
    - (ii) Address of building;
    - (iii) Date of construction;
    - (iv) Apartment numbers (if applicable);
    - (v) Name, address, and telephone number of the owner or owners of each residential dwelling or child-occupied facility;
    - (vi) Name, signature, and certification number of each certified inspector and risk assessor conducting testing;
    - (vii) Name, address, and telephone number of the certified firm employing each inspector and risk assessor, if applicable;
    - (viii) Each testing method and device and/or sampling procedure employed for paint analysis, including quality control data and, if used, the serial number of any x-ray fluorescence (XRF) device;
    - (ix) Specific locations of each painted component tested for the presence of lead-based paint; and

- (x) The results of the inspection expressed in terms appropriate to the sampling method used.
5. The inspection report required by part 4 of this subparagraph shall be made available to the Commissioner upon request.
- (c) Lead Hazard Screen.
- 1. A lead hazard screen shall be conducted only by a person certified by the Commissioner as a risk assessor.
  - 2. A lead hazard screen shall be conducted as follows:
    - (i) Background information regarding the physical characteristics of the residential dwelling or child-occupied facility and occupant use patterns that may cause lead-based paint exposure to one or more children age six years and under shall be collected.
    - (ii) A visual inspection of the residential dwelling or child-occupied facility shall be conducted to:
      - (I) Determine if any deteriorated paint is present, and
      - (II) Locate at least two dust sampling locations.
    - (iii) If deteriorated paint is present, each surface with deteriorated paint, that is determined, using documented methodologies, to be in poor condition and to have a distinct painting history, shall be tested for the presence of lead.
    - (iv) In residential dwellings, two composite dust samples shall be collected, one from the floors and the other from the windows, in rooms, hallways, or stairwells where one or more children, age six and under, are most likely to come in contact with dust.
    - (v) In multi-family dwellings and child-occupied facilities, in addition to the floor and window samples required in subpart (iv) of this part, the risk assessor shall also collect composite dust samples from common areas where one or more children, age six and under, are most likely to come into contact with dust.
  - 3. Dust samples shall be collected and analyzed in the following manner:
    - (i) All dust samples shall be taken using documented methodologies that incorporate adequate quality control procedures; and
    - (ii) All collected dust samples shall be analyzed according to subparagraph (g) of this paragraph to determine if they contain detectable levels of lead that can be quantified numerically.
  - 4. Paint shall be sampled in the following manner:
    - (i) The analysis of paint to determine the presence of lead shall be conducted using documented methodologies that incorporate adequate quality control procedures; and
    - (ii) All collected paint chip samples shall be analyzed according to subparagraph (g) of this paragraph to determine if they contain detectable levels of lead that can be quantified numerically.
  - 5. The risk assessor shall prepare a lead hazard screen report, which shall include the following information:

- (i) The information required in a risk assessment report as specified in subparagraph (d) of this paragraph, including subparts (d)11(i) through (xiv) of this paragraph, and excluding subparts (d)11(xv) through (xviii) of this paragraph. Additionally, any background information collected pursuant to subpart 2(i) of this subparagraph shall be included in the risk assessment report; and
  - (ii) Recommendations, if warranted, for a follow-up risk assessment, and as appropriate, any further actions.
- (d) Risk Assessment.
  1. A risk assessment shall be conducted only by a person certified by the Commissioner as a risk assessor and in accordance with the procedures of this subparagraph.
  2. A visual inspection for risk assessment of the residential dwelling or child-occupied facility shall be undertaken to locate the existence of deteriorated paint, assess the extent and causes of the deterioration, and access other potential lead-based paint hazards.
  3. Background information regarding the physical characteristics of the residential dwelling or child-occupied facility and occupant use patterns that may cause lead-based paint exposure to one or more children aged six years and under shall be collected.
  4. The following surfaces that are determined, using documented methodologies, to have a distinct painting history, shall be tested for the presence of lead:
    - (i) Each friction surface or impact surface with visibly deteriorated paint; and
    - (ii) All other surfaces with visibly deteriorated paint.
  5. In residential dwellings, dust samples (either composite or single surface samples) from the interior windowsill(s) and floor shall be collected and analyzed for lead concentration in all living areas where one or more children, aged six and under, are most likely to come into contact with dust.
  6. For multi-family dwellings and child-occupied facilities, the samples required in part 4 of this subparagraph shall be taken. In addition, interior windowsill and floor-dust samples (either composite or single surface samples) shall be collected and analyzed for lead concentration in the following locations:
    - (i) Common areas adjacent to the sampled residential dwelling or child-occupied facility; and
    - (ii) Other common areas in the building where the risk assessor determines that one or more children aged six and under are likely to come into contact with dust.
  7. For child-occupied facilities, interior windowsill and floor-dust samples (either composite or single surface samples) shall be collected and analyzed for lead concentration in each room, hallway, or stairwell utilized by one or more children, age six and under, and in other common areas in the child-occupied facility where one or more children, age six and under, are likely to come into contact with dust.
  8. Soil samples shall be collected and analyzed for lead concentrations in the following locations:
    - (i) Exterior play areas where bare soil is present;
    - (ii) The rest of the yard (i.e., non-play areas) where bare soil is present; and
    - (iii) Drip line/foundation areas where bare soil is present.
  9. Any paint, dust, or soil sampling or testing shall be conducted using documented

methodologies that incorporate adequate quality control procedures.

10. Any collected paint chip, dust, or soil samples shall be analyzed according to subparagraph (g) of this paragraph to determine if they contain detectable levels of lead that can be quantified numerically.
11. The certified risk assessor shall prepare a risk assessment report that includes the following information:
  - (i) Date of assessment;
  - (ii) Address of each building;
  - (iii) Date of construction of buildings;
  - (iv) Apartment number (if applicable);
  - (v) Name, address, and telephone number of each owner of each building;
  - (vi) Name, signature, and certification of the certified risk assessor conducting the assessment;
  - (vii) Name, address, and telephone number of the certified firm employing each certified risk assessor if applicable;
  - (viii) Name, address, and telephone number of each recognized laboratory conducting analysis of collected samples;
  - (ix) Results of the visual inspection;
  - (x) Testing method and sampling procedure for paint analysis employed;
  - (xi) Specific locations of each painted component tested for the presence of lead;
  - (xii) All data collected from on-site testing, including quality control data and, if used, the serial number of any XRF device;
  - (xiii) All results of laboratory analysis on collected paint, soil, and dust samples;
  - (xiv) Any other sampling results;
  - (xv) Any background information collected pursuant to part 3 of this subparagraph;
  - (xvi) To the extent that they are used as part of the lead-based paint hazard determination, the results of any previous inspections or analyses for the presence of lead-based paint, or other assessments of lead-based paint-related hazards;
  - (xvii) A description of the location, type, and severity of identified lead-based paint hazards and any other potential lead hazards; and
  - (xviii) A description of interim controls and/or abatement options for each identified lead-based paint hazard and a suggested prioritization for addressing each hazard. If the use of an encapsulant or enclosure is recommended, the report shall recommend a maintenance and monitoring schedule for the encapsulant or enclosure.

(e) Lead Hazard Reduction Specifications.

1. The abatement and lead hazard reduction specifications shall be unique to each residential dwelling or child-occupied facility and shall be developed before the abatement and lead hazard reduction occurs.

2. The certified supervisor or project designer shall also provide to the project owner, for each specification package, a detailed cost estimate to complete the general requirements, project execution, and the lead hazard reduction and abatement.
3. The abatement and lead hazard reduction project specifications shall be written to include the following information:
  - (i) Date of each project specification;
  - (ii) Address of building;
  - (iii) Name, signature, and certification number of each certified supervisor and/or project designer writing the project specification;
  - (iv) Name, address, and telephone number of the certified firm employing each supervisor and/or project designer, if applicable;
  - (v) Building construction date;
  - (vi) Apartment numbers (if applicable);
  - (vii) General Requirements and Conditions:
    - (I) Description of work;
    - (II) Terminology/definitions;
    - (III) Applicable federal, state, and local regulations, standards and guidelines;
    - (IV) Contractor qualifications and responsibilities;
    - (V) Contractor's employee qualifications
    - (VI) Scheduling of lead hazard reduction;
    - (VII) Worker protection;
    - (VIII) Occupant protection plan; and
    - (IX) Site preparation and levels of protection pursuant to the containment erected;
  - (viii) Products;
  - (ix) Execution:
    - (I) Work area preparation; and
    - (II) Work area containment;
  - (x) Site-Specific Hazard Reduction Measures:
    - (I) Detailed specification and procedures for lead hazard reduction and abatement for each area;
    - (II) Detailed clean-up requirements and clearance testing;
    - (III) Disposal of lead-based paint materials and lead-based paint waste and debris;

- (IV) Contractor's air monitoring and analysis;
  - (V) Medical monitoring;
  - (VI) Logbook; and
  - (VII) Submittals;
  - (xi) Site Lead-based Paint Inspection/Risk Assessment Data Sheets;
  - (xii) Site sketch depicting interior floors, rooms, windows, and exterior construction and structures; and
  - (xiii) Contractor's bid proposal sheet.
- (f) Abatement and Lead Hazard Reductions.
1. An abatement or lead hazard reduction shall be conducted only by firms and individuals certified by the Commissioner and in accordance with the procedures of this subparagraph.
  2. A certified supervisor is required for each abatement project and shall be onsite during all work site preparation and during the post-abatement cleanup of work areas. At all other times when abatement activities are being conducted, the certified supervisor shall be onsite or available by telephone, pager, or answering service and able to be present at the work site in no more than two hours.
  3. The certified supervisor and the certified firm employing that supervisor shall ensure that all abatement activities are conducted according to the requirements of this paragraph and all other federal, state, and local requirements.
  4. The following shall be maintained on site during lead-based paint abatement and lead-hazard reduction activities and be immediately made available for review by the Commissioner:
    - (i) A copy of the project review notification, project review acknowledgement to proceed, and all revisions;
    - (ii) The occupant protection plan;
    - (iii) A copy of the applicable lead-based paint abatement design, risk assessment, and inspection reports;
    - (iv) Photo identification certification card issued by the Commissioner for all certified persons and firms performing lead-based paint activities; and
    - (v) A bound logbook that shall include, but not be limited to, copies of any accident and injury report, results of all air sampling, receipts from the landfill (trip tickets), daily inspection notes concerning any deviation from the standard working procedures, sign-in/sign-out sheets of site visitors and workers, and any other pertinent documents, permits, notification, photographs, and records. The information required to be maintained by this part may be maintained electronically so long as it is available at all times on site and available for review by the Commissioner.
  5. A written occupant protection plan shall be developed for all abatement projects in accordance with the following procedures:
    - (i) The occupant protection plan shall be submitted to the Commissioner at least five days before the commencement of the lead hazard reduction.
    - (ii) The occupant protection plan shall be signed by a principal of the certified firm that

is under contract to perform the lead hazard control and abatement activities and the person who prepared the plan.

- (iii) The occupant protection plan shall be unique to each residential dwelling or child-occupied facility and shall be developed before the abatement. The occupant protection plan shall describe the measures and management procedures that will be taken during the abatement to protect the building occupants from exposure to any lead-based paint hazards. If exterior abatement is being conducted, the plan should also include the protection of persons within 10 feet per building story of the building's exterior.
- (iv) Either a certified supervisor or project designer may prepare the occupant protection plan for a single-family dwelling, a multi-family dwelling with 10 or fewer units, or a child-occupied facility less than or equal to 1200 square feet or a conversion project less than or equal to 1200 square feet.
- (v) Only a certified project designer may prepare the occupant protection plan for multi-family dwellings with 11 or more units or a child-occupied facility equal to or greater than 1201 square feet or a conversion project equal to or greater than 1201 square feet.
- (vi) The occupant protection plan shall contain the work site preparation level of containment as specified in the following tables for interior, exterior, and window treatment lead hazard control activities:

Interior Worksite Preparation Levels (Not Including Windows)				
Description	Level 1	Level 2	Level 3	Level 4
Typical Application (Hazard Controls)	Dust removal and any abatement or interim control method disturbing no more than two square feet of painted surface per room	Any interim control or abatement method disturbing between two and 10 square feet of painted surface per room	Same as Level 2.	Any interim control or abatement method disturbing more than 10 square feet per room.
Time Limit Per Dwelling	One workday.	One workday.	Five workdays.	None.
Resident Location	Inside dwelling, but outside work area. Resident must have lead-safe passage to bathroom, at least one living area, and entry/egress pathways. Alternatively, resident can leave the dwelling during the work day.	Same as Level 1.	Outside the dwelling; but can return in evening after day's work and cleanup are completed. Resident must have safe passage to bathroom, at least one living area, and entry/egress pathways upon return. Alternatively, resident can leave the dwelling until all work is completed.	Outside the dwelling for duration of project; cannot return until clearance has been achieved.
Containment and Barrier System	Single layer of plastic sheeting on floor extending five	Two layers of plastic on entire floor. Plastic sheet	Two layers of plastic on entire floor. Plastic sheet	Two layers of plastic on entire floor. If entire unit is

	feet beyond the perimeter of the treated area in all directions. No plastic sheeting on doorways is required, but a low physical barrier (furniture, wood planking) to prevent inadvertent access by resident is recommended. Children should not have access to plastic sheeting (suffocation hazard).	with primitive airlock flap on all doorways. Doors secured from inside the work area need not be sealed. Children should not have access to plastic sheeting (suffocation hazard).	with primitive airlock flap on all doorways to work areas. Doors secured from inside the work area need not be sealed. Overnight barrier should be locked or firmly secured. Children should not have access to plastic sheeting (suffocation hazard).	being treated, cleaned, and cleared, individual room doorways need not be sealed. If only a few rooms are being treated, seal all doorways with primitive airlock flap to avoid cleaning entire dwelling. Doors secured from inside the work area need not be sealed.
Warning Signs	Required at entry to room but not on building (unless exterior work is also under way).	Same as Level 1.	Posted at main and secondary entryways.	Posted at building exterior near main and secondary entryways.
Ventilation System	Dwelling ventilation system turned off, but vents need not be sealed with plastic if they are more than five feet away from the surface being treated. Negative pressure zones (with "negative air" machines) are not required, unless large supplies of fresh air must be admitted into the work area to control exposures to other hazardous substances (for example, solvent vapors).	Turned off and all vents in room sealed with plastic. Negative pressure zones (with "negative air" machines) are not required, unless large supplies of fresh air must be admitted into the work area to control exposures to other hazardous substances (for example, solvent vapors).	Same as Level 2.	Same as Level 2.
Furniture	Left in place uncovered if furniture is more than five feet from working surface. If within five feet, furniture should be sealed with a single layer of plastic or moved for paint treatment. No covering is required for dust removal.	Removed from work area. Large items that cannot be moved can be sealed with a single layer of plastic sheeting and left in work area.	Same as Level 2.	Same as Level 2.

Cleanup (See Chapter 14 of the U.S. Department of Housing and Urban Development Guidelines for the Evaluation and Control of Lead-Based Paint Hazards in Housing for further discussion of cleanup methods)	HEPA vacuum, wet wash, and HEPA vacuum all surfaces and floors extending 5 feet in all directions from the treated surface. For dust removal work alone, a HEPA vacuum and wet wash cycle is adequate (i.e., no second pass with a HEPA vacuum is needed). Also, wet wash and HEPA vacuum floor in adjacent area (s) used as pathway to work area. Do not store debris inside dwelling overnight; transfer to a locked secure area at the end each day.	HEPA vacuum, wet wash, and HEPA vacuum all surfaces in room. Also, wet wash and HEPA vacuum floor in adjacent area(s) used as pathway to work area. Do not store debris inside dwelling overnight; use a secure locked area.	Remove top layer of plastic from floor and discard. Keep bottom layer of plastic on floor for use on the next day. HEPA vacuum, wet wash, and HEPA vacuum all surfaces in room. Also, wet wash and HEPA vacuum floor in adjacent area(s) used as pathway to work area. Do not store debris inside dwelling overnight; use a secure locked area.	Full HEPA vacuum, wet wash, and HEPA vacuum cycle, as detailed in Chapter 14 of the U.S. Department of Housing and Urban Development Guidelines for the Evaluation and Control of Lead-Based Paint Hazards in Housing.
Dust Sampling	Clearance only.	Clearance only.	One sample collected outside work area every few jobs plus clearance.	Clearance only.

Exterior Worksite Preparation Levels (Not Including Windows)			
Description	Level 1	Level 2	Level 3
Typical Applications	Any interim control or abatement method disturbing less than 10 square feet of exterior painted surface per dwelling. Also includes soil control work.	Any interim control or abatement method disturbing 10 to 50 square feet of exterior painted surface per dwelling. Also includes soil control work.	Any interim control or abatement method disturbing more than 50 square feet of exterior painted surface per dwelling. Also includes soil control work.
Time Limit Per Dwelling	One day.	None.	None.
Resident Location	Inside dwelling but outside work area for duration of project until cleanup has been completed. Alternatively, resident can leave until all work has been completed. Resident must have lead-safe access to entry/egress pathways.	Relocated from dwelling during workday but may return after daily cleanup has been completed.	Relocation from dwelling for duration of project until final clearance is achieved.
Containment and Barrier System	One layer of plastic on ground extending 10 feet beyond the perimeter of	Same as Level 1.	Same as Level 1.

	working surfaces. Do not anchor ladder feet on top of plastic (puncture the plastic to anchor ladders securely to ground). For all other exterior plastic surfaces, protect plastic with boards to prevent puncture from falling debris, nails, etc., if necessary. Raise edges of plastic to create a basin to prevent of unexpected precipitation. Secure plastic to side of building with tape or other anchoring system (no gaps between plastic and building). Weight all plastic sheets down with two-by-fours or similar objects. Keep all windows within 20 feet of working surfaces closed, including windows of adjacent structures.		
Playground Equipment, Toys, Sandbox	Remove all movable items to a 20-foot distance from working surfaces. Items that cannot be readily moved to a 20-foot distance can be sealed with taped plastic sheeting.	Same as Level 1.	Same as Level 1.
Signs	Post warning signs on the building and at a 20-foot perimeter around building (or less if distance to next building or sidewalk is less than 20 feet).	Same as Level 1.	Same as Level 1.
Weather	Do not conduct work if wind speeds are greater than 20 miles per hour. Work must stop and cleanup must occur before rain begins.	Same as Level 1.	Same as Level 1.
Porches	One lead-safe entryway must be made available to residents at all times. Do not treat front and rear porches at the same time if there is not a third doorway.	Front and rear porches cannot be treated at the same time if unprotected workers must use the entryway.	Same as Level 2.
Dust & Soil Sampling	Clearance only.	Clearance only.	Clearance only.
Porches	One lead-safe entryway must be made available to residents at all times. Do not treat front and rear porches at the same time if there is	Front and rear porches cannot be treated at the same time if unprotected workers must use the entryway.	Same as Level 2.

	not a third doorway		
--	---------------------	--	--

Window Treatment or Replacement Work Preparation Levels	
Appropriate Applications	Any Window Treatment or Replacement.
Resident Location	Remain inside dwelling but outside work area until project has been completed. Alternatively, can leave until all work has been completed. Resident must have access to lead-safe entry/egress pathway.
Time Limit Per Dwelling	None.
Containment and Barrier System	One layer of plastic sheeting on ground or floor extending five feet beyond perimeter of window being treated/replaced. Two layers of plastic taped to interior wall if working on window from outside; if working from the inside, tape two layers of plastic to exterior wall. If working from inside; implement a minimum Interior Worksite Preparation Level 2. Children cannot be present in an interior room where plastic sheeting is located due to suffocation hazard. Do not anchor ladder feet on top of plastic (puncture the plastic to anchor ladders securely to ground). For all other exterior plastic surfaces, protect plastic with boards to prevent puncture from falling debris, nails, etc. (if necessary). Secure plastic to side of building with tape or other anchoring system (no gaps between plastic and building). Weigh all plastic sheets down with two-by-fours or similar objects. All windows in dwelling should be kept closed. All windows in adjacent dwelling that are closer than 20 feet to the work area should be kept closed.
Signs	Post warning signs on the building and at a 20-foot perimeter around building (or less if distance to next building or sidewalk is less than 20 feet). If window is to be removed from inside, no exterior sign is necessary.
Security	Erect temporary fencing or barrier tape at a 20-foot perimeter around building (or less if distance to next building or sidewalk is less than 20 feet). Use a locked dumpster, covered truck, or locked room to store debris before disposal.
Weather	Do not conduct work if wind speeds are greater than 20 miles per hour. Work must stop and cleanup must occur before rain begins, or work should proceed from the inside only.
Playground Equipment, Toys, Sandbox	Removed from work area and adjacent areas. Remove all items to a 20-foot distance from dwelling. Large, unmovable items can be sealed with taped plastic sheeting.
Cleaning	If working from inside, HEPA vacuum, wet wash, and HEPA vacuum all interior surfaces within 10 feet of work area in all directions. If working from the exterior, no cleaning of the interior is needed, unless the containment is breached. Similarly, no cleaning is needed on the exterior if all work is done on the interior and the containment is not breached. If containment is breached, then cleaning on both sides of the window should be performed. No debris or plastic should be left out overnight if work is not completed. All debris must be kept in a secure area until final disposal.

6. After the commencement of an abatement project, all persons within a containment area shall be lead-based paint abatement personnel certified by the Commissioner.
7. The work practices listed below shall be restricted during an abatement as follows:
  - (i) Open-flame burning or torching of lead-based paint is prohibited;

- (ii) Machine sanding or grinding or abrasive blasting or sandblasting of lead-based paint is prohibited unless used with High Efficiency Particulate Air (HEPA) exhaust control that removes particles of 0.3 microns or larger from the air at 99.97 percent or greater efficiency;
  - (iii) Dry scraping of lead-based paint is permitted only in conjunction with heat guns or around electrical outlets or when treating defective paint spots totaling no more than two square feet in any one room, hallway, or stairwell or totaling no more than 20 square feet on exterior surfaces; and
  - (iv) Operating a heat gun on lead-based paint is permitted only at temperatures below 1100 degrees Fahrenheit.
8. Soil abatement shall be conducted as follows:
- (i) If soil is removed:
    - (I) Removed soil shall be replaced by soil with a lead concentration as close to local background as practicable, but no greater than 400 ppm.
    - (II) Removed soil shall not be used as topsoil at another residential property or child-occupied facility.
  - (ii) If soil is not removed, the soil shall be rendered permanently covered soil.
9. The following post-abatement clearance procedures shall be performed only by a certified inspector or risk assessor:
- (i) Following an abatement, a visual inspection shall be performed by a lead-based paint certified inspector or risk assessor to determine if deteriorated painted surfaces or visible amounts of dust, debris, or residue are still present. If deteriorated painted surfaces or visible amounts of dust, debris, or residue are present, these conditions must be eliminated prior to continuation of the clearance procedures.
  - (ii) Following the visual inspection and any post-abatement cleanup required by subpart (i) of this part, clearance sampling for lead in dust shall be conducted. Clearance sampling may be conducted by employing single-surface sampling or composite sampling techniques.
  - (iii) Dust samples for clearance purposes shall be taken using documented methodologies that incorporate adequate quality control procedures.
  - (iv) Dust samples for clearance purposes shall be taken a minimum of one hour after completion of final post-abatement cleanup activities.
  - (v) The following post-abatement clearance activities shall be conducted as appropriate based upon the extent or manner of abatement activities conducted in or to the residential dwelling or child-occupied facility:
    - (I) After conducting an abatement with containment between abated and unabated areas, one dust sample shall be taken from one interior windowsill and from one window trough (if present) and one dust sample shall be taken from the floors of each of no less than four rooms, hallways, or stairwells within the containment area. In addition, one dust sample shall be taken from the floor outside the containment area. If there are less than four rooms, hallways, or stairwells within the containment area, then all rooms, hallways, or stairwells shall be sampled.
    - (II) After conducting an abatement with no containment, two dust samples shall be taken from each of no less than four rooms, hallways, or stairwells

in the residential dwelling or child-occupied facility. One dust sample shall be taken from one interior windowsill and window trough (if present) of each room, and one dust sample shall be taken from the floor of each room, hallway, or stairwell selected. If there are less than four rooms, hallways, or stairwells within the residential dwelling or child-occupied facility then all rooms, hallways, or stairwells shall be sampled.

- (III) Following an exterior paint abatement, a visible inspection shall be conducted. All horizontal surfaces in the outdoor living area closest to the abated surface shall be found to be cleaned of visible dust and debris. In addition, a visual inspection shall be conducted to determine the presence of paint chips on the drip line or next to the foundation below any exterior surface abated. If paint chips are present, they must be removed from the site and properly disposed of according to all applicable federal, State, and local requirements.
  - (vi) The rooms, hallways, or stairwells selected for sampling shall be selected according to documented methodologies.
  - (vii) The certified inspector or risk assessor shall compare the residual lead level (as determined by the laboratory analysis) from each single surface dust sample with clearance levels in subpart (viii) of this part for lead in dust on floors, interior windowsills, and window troughs or from each composite dust sample with the applicable clearance levels for lead in dust on floors, interior windowsills, and window troughs divided by half the number of subsamples in the composite sample. If the residual lead level in a single surface dust sample equals or exceeds the applicable clearance level or if the residual lead level in a composite dust sample equals or exceeds the applicable clearance level divided by half the number of subsamples in the composite sample, the components represented by the failed sample shall be re-cleaned and retested.
  - (viii) The clearance levels for lead in dust are 10  $\mu\text{g}/\text{ft}^2$  for floors, 100  $\mu\text{g}/\text{ft}^2$  for interior windowsills, and 400  $\mu\text{g}/\text{ft}^2$  for window troughs.
10. In a multi-family dwelling with similarly constructed and maintained residential dwellings, random sampling for the purpose of clearance may be conducted provided:
- (i) The certified individuals who abate or clean the residential dwellings do not know which residential dwelling will be selected for the random sample.
  - (ii) A sufficient number of residential dwellings are selected for dust sampling to provide a 95% level of confidence that no more than 5% or 50 of the residential dwellings (whichever is smaller) in the randomly sampled population exceed the appropriate clearance levels.
  - (iii) The randomly selected residential dwellings shall be sampled and evaluated for clearance according to the procedures found in part 9 of this subparagraph.
11. An abatement report and project specifications shall be prepared by a certified supervisor or project designer for single family dwellings or multi-family dwellings with 10 or fewer units. A certified project designer shall prepare an abatement report and project specifications for child-occupied facilities and multi-family dwellings having 11 or more units. The completed abatement report shall be submitted to the Commissioner no more than 15 days following the completion of the abatement project. Any project specifications shall meet the requirements in part (e)3 of this paragraph. The abatement report shall include the following information:
- (i) Start and completion dates of abatement and a copy of the Project Review Acknowledgement to Proceed obtained from the Commissioner;
  - (ii) The name and address of each certified firm conducting the abatement and the

name of each supervisor assigned to the abatement project;

- (iii) The occupant protection plan prepared pursuant to part 5 of this subparagraph;
- (iv) The name, address, and signature of each certified risk assessor or inspector conducting clearance sampling and the date of clearance testing;
- (v) The results of clearance testing and all soil analyses (if applicable) and the name of each recognized laboratory that conducted the analyses; and
- (vi) A detailed written description of the abatement, including abatement methods used, locations of rooms and components where abatement occurred, the reason for selecting particular abatement methods for each component, and any suggested monitoring of encapsulants or enclosures.

(g) Collection and Laboratory Analysis of Samples.

Any paint chip, dust, or soil sample collected pursuant to the work practice standards contained in this paragraph shall be:

- 1. Collected by persons certified by the Commissioner as an inspector or risk assessor; and
- 2. Analyzed by a laboratory recognized by the National Lead Laboratory Accreditation Program or equivalent and capable of performing analyses for lead compounds in paint chip, dust, and soil samples pursuant to TSCA 15 U.S.C. § 2685(b) laboratory requirements.

(h) Composite Dust Sampling.

Composite dust sampling may only be conducted in the situations specified in subparagraphs (c), (d), and (f) of this paragraph. If such sampling is conducted, the following conditions apply:

- 1. Composite dust samples shall consist of at least two subsamples;
- 2. Every component that is being tested shall be included in the sampling; and
- 3. Composite dust samples shall not consist of subsamples from more than one type of component.

(i) Determinations.

- 1. Lead-based paint is present:
  - (i) On any surface that is tested and found to contain lead equal to or in excess of 1.0 milligrams per square centimeter or equal to or in excess of 0.5% by weight; or
  - (ii) On any surface like a surface tested in the same room equivalent that has a similar painting history and that is found to be lead-based paint.
- 2. A paint-lead hazard is present:
  - (i) On any friction surface that is subject to abrasion and where the lead dust levels on the nearest horizontal surface underneath the friction surface (e.g., the windowsill or floor) are equal to or greater than the dust hazard levels identified in subpart (f)9(viii) of this paragraph; or
  - (ii) On any chewable lead-based paint surface on which there is evidence of teeth marks; or
  - (iii) Where there is any damaged or otherwise deteriorated lead-based paint on an impact surface that is caused by impact from a related building component (such

as a doorknob that knocks into a wall or a door that knocks against its door frame);  
or

- (iv) If there is any other deteriorated lead-based paint in any residential building or child-occupied facility or on the exterior of any residential building or child-occupied facility.

3. A dust-lead hazard is present in a residential dwelling or child occupied facility:

- (i) In a residential dwelling on floors and interior windowsills when the weighted arithmetic mean lead loading for all single surface or composite samples of floors and interior windowsills window sills are equal to or greater than 10  $\mu\text{g}/\text{ft}^2$  for floors and 100  $\mu\text{g}/\text{ft}^2$  for interior windowsills, respectively;
- (ii) On floors or interior windowsills in an unsampled residential dwelling in a multi-family dwelling, if a dust-lead hazard is present on floors or interior windowsills, respectively, in at least one sampled residential unit on the property; and
- (iii) On floors or interior windowsills in an unsampled common area in a multi-family dwelling, if a dust-lead hazard is present on floors or interior windowsills, respectively, in at least one sampled common area in the same common area group on the property.

4. A soil-lead hazard is present:

- (i) In a play area when the soil-lead concentration from a composite play area sample of bare soil is equal to or greater than 400 parts per million; or
- (ii) In the rest of the yard when the arithmetic mean lead concentration from a composite sample (or arithmetic mean of composite samples) of bare soil from the rest of the yard (i.e., non-play areas) for each residential building on a property is equal to or greater than 1,200 parts per million.

(j) Recordkeeping.

All reports or plans required in this paragraph shall be maintained on site by the certified supervisor during abatement activities and by the certified firm or individual that prepared the report for no fewer than three years. The certified firm or individual also shall provide copies of these reports to the building owner who contracted for its services.

(k) Notification.

A certified firm must notify the Commissioner of lead-based paint activities as follows:

1. Except as provided in part 2 of this subparagraph, the Commissioner must be notified prior to conducting lead-based paint activities. The original notification must be received by the Commissioner at least five business days before the start date of any lead-based paint activities.
2. Notification for lead-based paint activities required in response to an elevated blood lead level (EBLL) determination, or federal, State, or local emergency abatement order, should be received by the Commissioner as early as possible before, but must be received no later than, the start date of the lead-based paint activities. Should the start date or location provided to the Commissioner change, an updated notification must be received by the Commissioner on or before the start date provided to the Commissioner. Documentation showing evidence of an EBLL determination or a copy of the federal, state, Tribal, or local emergency abatement order must be included in the written notification to take advantage of this abbreviated notification period.
3. Except as provided in part 2 of this subparagraph, updated notification must be provided

to the Commissioner for lead-based paint activities that will begin on a date other than the start date specified in the original notification as follows:

- (i) For lead-based paint activities beginning prior to the start date provided to the Commissioner, an updated notification must be received by the Commissioner at least five business days before the new start date included in the notification.
  - (ii) For lead-based paint activities beginning after the start date provided to the Commissioner, an updated notification must be received by the Commissioner on or before the start date provided to the Commissioner.
4. Except as provided in part 2 of this subparagraph, updated notification must be provided to the Commissioner for any change in location of lead-based paint activities at least five business days prior to the start date provided to the Commissioner.
5. Updated notification must be provided to the Commissioner when lead-based paint activities are canceled or when there are other significant changes including, but not limited to, when the square footage or acreage to be abated changes by more than 20%. This updated notification must be received by the Commissioner on or before the start date provided to the Commissioner, or if work has already begun, within 24 hours of the change.
6. The following must be included in each notification:
  - (i) Notification type (original, updated, cancellation);
  - (ii) Date when lead-based paint activities will start;
  - (iii) Date when lead-based paint activities will end (approximation using best professional judgment);
  - (iv) Firm's name, certification number, address, and telephone number;
  - (v) Type of building (e.g., single family dwelling, multi-family dwelling, child-occupied facilities) on/in which abatement work will be performed;
  - (vi) Property name (if applicable);
  - (vii) Property address including apartment or unit number(s) (if applicable) for abatement work;
  - (viii) If using the abbreviated time period as described in part 2 of this subparagraph, documentation showing evidence of an EBLL determination or a copy of the federal, State, Tribal, or local emergency abatement order;
  - (ix) Name and certification number of the project supervisor;
  - (x) Approximate square footage or acreage to be abated;
  - (xi) Brief description of abatement, risk assessment, inspection, lead hazard screen, lead hazard reduction, and clearance activities to be performed; and
  - (xii) Name, title, and signature of the representative of the certified firm who prepared the notification.
7. Notification must be made by written notification or electronically by such means approved by the Commissioner. Written notification can be accomplished using the Division form titled "Lead-Based Paint Activity Notification," or a successor to that form approved by the Commissioner. All written notification must be delivered by U.S. Postal Service, fax, commercial delivery service, or hand delivery.
8. In the event of changes to the original notification, lead-based paint activities shall not begin

on a date or at location other than that specified in either an original or updated notification.

9. No firm or individual shall engage in lead-based paint activities prior to notifying the Commissioner of such activities according to the requirements of this subparagraph.

# **SECTION 6**

## **Model Respiratory Protection Plan**

### **U.S. Occupational Safety and Health Regulations for Construction**

#### **29 CFR 1926.62 - Lead**

#### **29 C.F.R. 1910.134 - Respiratory Protection**

# **Model Respiratory Protection Program**

Before engaging in any lead abatement project, the lead abatement contractor primarily responsible for the project shall prepare a written respirator protection plan according to the U. S. Occupational Safety and Health Administration standards on respiratory protection, 29 C.F.R. 1910.134 and Appendix D of 29 C.F.R 1926.62 and must make the plan available to all lead abatement workers at the project site.

The following is a model respiratory protection program. This model was created to help lead abatement contractors in understanding the importance of a respiratory protection program.

# Sample Respiratory Protection Program for Employees

## Introduction

This program has been developed to comply with the OSHA Construction Lead Standard 29 C.F.R. 1926.62 and OSHA Respiratory Protection Standard 29 C.F.R. 1910.134.

This respiratory protection program is intended for those employees who work in lead abatement. This standard does not outline situations where other hazards are involved. All employees will be trained and instructed in the proper use of respirators and their limitations. Persons should not be assigned to tasks requiring the use of a respirator unless it has been determined that they are physically able to perform the work and use the equipment. Medical exams will be offered to all employees of **Model Company, Inc.** prior to respirator training and instruction.

## When is a respirator necessary in lead abatement?

**Model Company, Inc.** will provide employees respirators in the following situations:

- 1) When the exposure to lead exceeds the PEL (Permissible Exposure Limit,) a respirator is required.
- 2) In work situations when engineering controls and work practices do not lower exposure to or below the PEL, the employee must wear a respirator.
- 3) Whenever an employee requests a respirator, one will be provided.
- 4) Until employee exposure can be determined, a respirator must be worn. The Permissible Exposure Limit for lead is 50Fg/m<sup>3</sup> over an eight-hour work shift. If an employee's exposure to lead **exceeds** this amount, a respirator must be worn. The employee has the right to request a respirator if the exposure falls below 50Fg/m<sup>3</sup>. A respirator will be provided by Model Company, Inc. whenever an employee requests one.

Certain work practices and engineering controls will be used to try to lower the exposure to lead. Sometimes these practices won't lower the exposure below 50Fg/m<sup>3</sup>. A respirator must be worn in these conditions. Anytime the exposure exceeds the PEL a respirator must be worn.

# Electronic Code of Federal Regulation S

e-CFR data is current as of **April 7, 2020**

[Title 29](#) → [Subtitle B](#) → [Chapter XVII](#) → Part 1926

---

[↑ Return to Search Results](#)

[Browse Previous](#) | [Browse Next](#)

Title 29: Labor

## **§1926.62 Lead.**

(a) *Scope.* This section applies to all construction work where an employee may be occupationally exposed to lead. All construction work excluded from coverage in the general industry standard for lead by 29 CFR 1910.1025(a)(2) is covered by this standard. Construction work is defined as work for construction, alteration and/or repair, including painting and decorating. It includes but is not limited to the following:

- (1) Demolition or salvage of structures where lead or materials containing lead are present;
- (2) Removal or encapsulation of materials containing lead;
- (3) New construction, alteration, repair, or renovation of structures, substrates, or portions thereof, that contain lead, or materials containing lead;
- (4) Installation of products containing lead;
- (5) Lead contamination/emergency cleanup;
- (6) Transportation, disposal, storage, or containment of lead or materials containing lead on the site or location at which construction activities are performed, and
- (7) Maintenance operations associated with the construction activities described in this paragraph.

### *(b) Definitions.*

*Action level* means employee exposure, without regard to the use of respirators, to an airborne concentration of lead of 30 micrograms per cubic meter of air (30 µg/m<sup>3</sup>) calculated as an 8-hour time-weighted average (TWA).

*Assistant Secretary* means the Assistant Secretary of Labor for Occupational Safety and Health, U.S. Department of Labor, or designee.

*Competent person* means one who is capable of identifying existing and predictable lead hazards in the surroundings or working conditions and who has authorization to take prompt corrective measures to eliminate them.

*Director* means the Director, National Institute for Occupational Safety and Health (NIOSH), U.S. Department of Health and Human Services, or designee.

*Lead* means metallic lead, all inorganic lead compounds, and organic lead soaps. Excluded from this definition are all other organic lead compounds.

*This section* means this standard.

(c) *Permissible exposure limit.* (1) The employer shall assure that no employee is exposed to lead at concentrations greater than fifty micrograms per cubic meter of air ( $50 \mu\text{g}/\text{m}^3$ ) averaged over an 8-hour period.

(2) If an employee is exposed to lead for more than 8 hours in any work day the employees' allowable exposure, as a time weighted average (TWA) for that day, shall be reduced according to the following formula:

Allowable employee exposure (in  $\mu\text{g}/\text{m}^3$ ) = 400 divided by hours worked in the day.

(3) When respirators are used to limit employee exposure as required under paragraph (c) of this section and all the requirements of paragraphs (e)(1) and (f) of this section have been met, employee exposure may be considered to be at the level provided by the protection factor of the respirator for those periods the respirator is worn. Those periods may be averaged with exposure levels during periods when respirators are not worn to determine the employee's daily TWA exposure.

(d) *Exposure assessment—(1) General.* (i) Each employer who has a workplace or operation covered by this standard shall initially determine if any employee may be exposed to lead at or above the action level.

(ii) For the purposes of paragraph (d) of this section, employee exposure is that exposure which would occur if the employee were not using a respirator.

(iii) With the exception of monitoring under paragraph (d)(3), where monitoring is required under this section, the employer shall collect personal samples representative of a full shift including at least one sample for each job classification in each work area either for each shift or for the shift with the highest exposure level.

(iv) Full shift personal samples shall be representative of the monitored employee's regular, daily exposure to lead.

(2) *Protection of employees during assessment of exposure.* (i) With respect to the lead related tasks listed in paragraph (d)(2)(i) of this section, where lead is present, until the employer performs an employee exposure assessment as required in paragraph (d) of this section and documents that the employee performing any of the listed tasks is not exposed above the PEL, the employer shall treat the employee as if the employee were exposed above the PEL, and not in excess of ten (10) times the PEL, and shall implement employee protective measures prescribed in paragraph (d)(2)(v) of this section. The tasks covered by this requirement are:

(A) Where lead containing coatings or paint are present: Manual demolition of structures (e.g, dry wall), manual scraping, manual sanding, heat gun applications, and power tool cleaning with dust collection systems;

(B) Spray painting with lead paint.

(ii) In addition, with regard to tasks not listed in paragraph (d)(2)(i), where the employee has any reason to believe that an employee performing the task may be exposed to lead in excess of the PEL, until the employer performs an employee exposure assessment as required by paragraph (d) of this section and documents that the employee's lead exposure is not above the PEL the employer shall treat the employee as if the employee were exposed above the PEL and shall implement employee protective measures as prescribed in paragraph (d)(2)(v) of this section.

(iii) With respect to the tasks listed in this paragraph (d)(2)(iii) of this section, where lead is present, until the employer performs an employee exposure assessment as required in this paragraph (d), and documents that the employee performing any of the listed tasks is not exposed in excess of  $500 \mu\text{g}/\text{m}^3$ , the employer shall treat the employee as if the employee were exposed to lead in excess of  $500 \mu\text{g}/\text{m}^3$  and shall implement employee protective measures as prescribed in paragraph (d)(2)(v) of this section. Where the employer does establish that the employee is exposed to levels of lead below  $500 \mu\text{g}/\text{m}^3$ , the employer may provide the exposed employee with the appropriate respirator prescribed for such use at such lower exposures, in accordance with paragraph (f) of this section. The tasks covered by this requirement are:

(A) Using lead containing mortar; lead burning

(B) Where lead containing coatings or paint are present: rivet busting; power tool cleaning without dust collection systems; cleanup activities where dry expendable abrasives are used; and abrasive blasting enclosure movement and removal.

(iv) With respect to the tasks listed in this paragraph (d)(2)(iv), where lead is present, until the employer performs an employee exposure assessment as required in this paragraph (d) and documents that the employee performing any of the listed tasks is not exposed to lead in excess of  $2,500 \mu\text{g}/\text{m}^3$  ( $50 \times \text{PEL}$ ), the employer shall treat the employee as if the employee were exposed to lead in excess of  $2,500 \mu\text{g}/\text{m}^3$  and shall implement employee protective measures as prescribed in paragraph (d)(2)(v) of this section. Where the employer does establish that the employee is exposed to levels of lead below  $2,500 \mu\text{g}/\text{m}^3$ , the employer may provide the exposed employee with the appropriate respirator prescribed for use at such lower exposures, in accordance with paragraph (f) of this section. Interim protection as described in this paragraph is required where lead containing coatings or paint are present on structures when performing:

(v) Until the employer performs an employee exposure assessment as required under paragraph (d) of this section and determines actual employee exposure, the employer shall provide to employees performing the tasks described in paragraphs (d)(2)(i), (d)(2)(ii), (d)(2)(iii), and (d)(2)(iv) of this section with interim protection as follows:

(A) Appropriate respiratory protection in accordance with paragraph (f) of this section.

(B) Appropriate personal protective clothing and equipment in accordance with paragraph (g) of this section.

(C) Change areas in accordance with paragraph (i)(2) of this section.

(D) Hand washing facilities in accordance with paragraph (i)(5) of this section.

(E) Biological monitoring in accordance with paragraph (j)(1)(i) of this section, to consist of blood sampling and analysis for lead and zinc protoporphyrin levels, and

(F) Training as required under paragraph (l)(1)(i) of this section regarding 29 CFR 1926.59, Hazard Communication; training as required under paragraph (1)(2)(iii) of this section, regarding use of respirators; and training in accordance with 29 CFR 1926.21, Safety training and education.

(3) *Basis of initial determination.* (i) Except as provided under paragraphs (d)(3)(iii) and (d)(3)(iv) of this section the employer shall monitor employee exposures and shall base initial determinations on the employee exposure monitoring results and any of the following, relevant considerations:

(A) Any information, observations, or calculations which would indicate employee exposure to lead;

(B) Any previous measurements of airborne lead; and

(C) Any employee complaints of symptoms which may be attributable to exposure to lead.

(ii) Monitoring for the initial determination where performed may be limited to a representative sample of the exposed employees who the employer reasonably believes are exposed to the greatest airborne concentrations of lead in the workplace.

(iii) Where the employer has previously monitored for lead exposures, and the data were obtained within the past 12 months during work operations conducted under workplace conditions closely resembling the processes, type of material, control methods, work practices, and environmental conditions used and prevailing in the employer's current operations, the employer may rely on such earlier monitoring results to satisfy the requirements of paragraphs (d)(3)(i) and (d)(6) of this section if the sampling and analytical methods meet the accuracy and confidence levels of paragraph (d)(9) of this section.

(iv) Where the employer has objective data, demonstrating that a particular product or material containing lead or a specific process, operation or activity involving lead cannot result in employee

exposure to lead at or above the action level during processing, use, or handling, the employer may rely upon such data instead of implementing initial monitoring.

(A) The employer shall establish and maintain an accurate record documenting the nature and relevancy of objective data as specified in paragraph (n)(4) of this section, where used in assessing employee exposure in lieu of exposure monitoring.

(B) Objective data, as described in paragraph (d)(3)(iv) of this section, is not permitted to be used for exposure assessment in connection with paragraph (d)(2) of this section.

(4) *Positive initial determination and initial monitoring.* (i) Where a determination conducted under paragraphs (d) (1), (2) and (3) of this section shows the possibility of any employee exposure at or above the action level the employer shall conduct monitoring which is representative of the exposure for each employee in the workplace who is exposed to lead.

(iii) Where the employer has previously monitored for lead exposures, and the data were obtained within the past 12 months during work operations conducted under workplace conditions closely resembling the processes, type of material, control methods, work practices, and environmental conditions used and prevailing in the employer's current operations, the employer may rely on such earlier monitoring results to satisfy the requirements of paragraphs (d)(3)(i) and (d)(6) of this section if the sampling and analytical methods meet the accuracy and confidence levels of paragraph (d)(9) of this section.

(5) *Negative initial determination.* Where a determination, conducted under paragraphs (d) (1), (2), and (3) of this section is made that no employee is exposed to airborne concentrations of lead at or above the action level the employer shall make a written record of such determination. The record shall include at least the information specified in paragraph (d)(3)(i) of this section and shall also include the date of determination, location within the worksite, and the name of each employee monitored.

(6) *Frequency.* (i) If the initial determination reveals employee exposure to be below the action level further exposure determination need not be repeated except as otherwise provided in paragraph (d)(7) of this section.

(ii) If the initial determination or subsequent determination reveals employee exposure to be at or above the action level but at or below the PEL the employer shall perform monitoring in accordance with this paragraph at least every 6 months. The employer shall continue monitoring at the required frequency until at least two consecutive measurements, taken at least 7 days apart, are below the action level at which time the employer may discontinue monitoring for that employee except as otherwise provided in paragraph (d)(7) of this section.

(iii) If the initial determination reveals that employee exposure is above the PEL the employer shall perform monitoring quarterly. The employer shall continue monitoring at the required frequency until at least two consecutive measurements, taken at least 7 days apart, are at or below the PEL but at or above the action level at which time the employer shall repeat monitoring for that employee at the frequency specified in paragraph (d)(6)(ii) of this section, except as otherwise provided in paragraph (d)(7) of this section. The employer shall continue monitoring at the required

frequency until at least two consecutive measurements, taken at least 7 days apart, are below the action level at which time the employer may discontinue monitoring for that employee except as otherwise provided in paragraph (d)(7) of this section.

(7) *Additional exposure assessments.* Whenever there has been a change of equipment, process, control, personnel or a new task has been initiated that may result in additional employees being exposed to lead at or above the action level or may result in employees already exposed at or above the action level being exposed above the PEL, the employer shall conduct additional monitoring in accordance with this paragraph.

(8) *Employee notification.* (i) The employer must, as soon as possible but no later than 5 working days after the receipt of the results of any monitoring performed under this section, notify each affected employee of these results either individually in writing or by posting the results in an appropriate location that is accessible to employees.

(ii) Whenever the results indicate that the representative employee exposure, without regard to respirators, is at or above the PEL the employer shall include in the written notice a statement that the employees exposure was at or above that level and a description of the corrective action taken or to be taken to reduce exposure to below that level.

(9) *Accuracy of measurement.* The employer shall use a method of monitoring and analysis which has an accuracy (to a confidence level of 95%) of not less than plus or minus 25 percent for airborne concentrations of lead equal to or greater than 30  $\mu\text{g}/\text{m}^3$ .

(e) *Methods of compliance—(1) Engineering and work practice controls.* The employer shall implement engineering and work practice controls, including administrative controls, to reduce and maintain employee exposure to lead to or below the permissible exposure limit to the extent that such controls are feasible. Wherever all feasible engineering and work practices controls that can be instituted are not sufficient to reduce employee exposure to or below the permissible exposure limit prescribed in paragraph (c) of this section, the employer shall nonetheless use them to reduce employee exposure to the lowest feasible level and shall supplement them by the use of respiratory protection that complies with the requirements of paragraph (f) of this section.

(2) *Compliance program.* (i) Prior to commencement of the job each employer shall establish and implement a written compliance program to achieve compliance with paragraph (c) of this section.

(ii) Written plans for these compliance programs shall include at least the following:

(A) A description of each activity in which lead is emitted; e.g. equipment used, material involved, controls in place, crew size, employee job responsibilities, operating procedures and maintenance practices;

(B) A description of the specific means that will be employed to achieve compliance and, where engineering controls are required engineering plans and studies used to determine methods selected for controlling exposure to lead;

(C) A report of the technology considered in meeting the PEL;

(D) Air monitoring data which documents the source of lead emissions;

(E) A detailed schedule for implementation of the program, including documentation such as copies of purchase orders for equipment, construction contracts, etc.;

(F) A work practice program which includes items required under paragraphs (g), (h) and (i) of this section and incorporates other relevant work practices such as those specified in paragraph (e)(5) of this section;

(G) An administrative control schedule required by paragraph (e)(4) of this section, if applicable;

(H) A description of arrangements made among contractors on multi-contractor sites with respect to informing affected employees of potential exposure to lead and with respect to responsibility for compliance with this section as set-forth in §1926.16.

(I) Other relevant information.

(iii) The compliance program shall provide for frequent and regular inspections of jobsites, materials, and equipment to be made by a competent person.

(iv) Written programs shall be submitted upon request to any affected employee or authorized employee representatives, to the Assistant Secretary and the Director, and shall be available at the worksite for examination and copying by the Assistant Secretary and the Director.

(v) Written programs must be revised and updated at least annually to reflect the current status of the program.

(3) *Mechanical ventilation.* When ventilation is used to control lead exposure, the employer shall evaluate the mechanical performance of the system in controlling exposure as necessary to maintain its effectiveness.

(4) *Administrative controls.* If administrative controls are used as a means of reducing employees TWA exposure to lead, the employer shall establish and implement a job rotation schedule which includes:

(i) Name or identification number of each affected employee;

(ii) Duration and exposure levels at each job or work station where each affected employee is located; and

(iii) Any other information which may be useful in assessing the reliability of administrative controls to reduce exposure to lead.

(5) The employer shall ensure that, to the extent relevant, employees follow good work practices such as described in appendix B of this section.

(f) *Respiratory protection*—(1) *General*. For employees who use respirators required by this section, the employer must provide each employee an appropriate respirator that complies with the requirements of this paragraph. Respirators must be used during:

(i) Periods when an employee's exposure to lead exceeds the PEL.

(ii) Work operations for which engineering and work-practice controls are not sufficient to reduce employee exposures to or below the PEL.

(iii) Periods when an employee requests a respirator.

(iv) Periods when respirators are required to provide interim protection of employees while they perform the operations specified in paragraph (d)(2) of this section.

(2) *Respirator program*. (i) The employer must implement a respiratory protection program in accordance with §1910.134(b) through (d) (except (d)(1)(iii)), and (f) through (m), which covers each employee required by this section to use a respirator.

(ii) If an employee has breathing difficulty during fit testing or respirator use, the employer must provide the employee with a medical examination in accordance with paragraph (j)(3)(i)(B) of this section to determine whether or not the employee can use a respirator while performing the required duty.

(3) *Respirator selection*. (i) Employers must:

(A) Select, and provide to employees, the appropriate respirators specified in paragraph (d)(3)(i)(A) of 29 CFR 1910.134.

(B) Provide employees with a full facepiece respirator instead of a half mask respirator for protection against lead aerosols that may cause eye or skin irritation at the use concentrations.

(C) Provide HEPA filters for powered and non-powered air-purifying respirators.

(ii) The employer must provide a powered air-purifying respirator when an employee chooses to use such a respirator and it will provide adequate protection to the employee.

(g) *Protective work clothing and equipment*—(1) *Provision and use*. Where an employee is exposed to lead above the PEL without regard to the use of respirators, where employees are exposed to lead compounds which may cause skin or eye irritation (e.g. lead arsenate, lead azide), and as interim protection for employees performing tasks as specified in paragraph (d)(2) of this section, the employer shall provide at no cost to the employee and assure that the employee uses appropriate protective work clothing and equipment that prevents contamination of the employee and the employee's garments such as, but not limited to:

(i) Coveralls or similar full-body work clothing;

(ii) Gloves, hats, and shoes or disposable shoe coverlets; and

(iii) Face shields, vented goggles, or other appropriate protective equipment which complies with §1910.133 of this chapter.

(2) *Cleaning and replacement.* (i) The employer shall provide the protective clothing required in paragraph (g)(1) of this section in a clean and dry condition at least weekly, and daily to employees whose exposure levels without regard to a respirator are over 200 µg/m<sup>3</sup> of lead as an 8-hour TWA.

(ii) The employer shall provide for the cleaning, laundering, and disposal of protective clothing and equipment required by paragraph (g)(1) of this section.

(iii) The employer shall repair or replace required protective clothing and equipment as needed to maintain their effectiveness.

(iv) The employer shall assure that all protective clothing is removed at the completion of a work shift only in change areas provided for that purpose as prescribed in paragraph (i)(2) of this section.

(v) The employer shall assure that contaminated protective clothing which is to be cleaned, laundered, or disposed of, is placed in a closed container in the change area which prevents dispersion of lead outside the container.

(vi) The employer shall inform in writing any person who cleans or launders protective clothing or equipment of the potentially harmful effects of exposure to lead.

(vii)(A) The employer shall ensure that the containers of contaminated protective clothing and equipment required by paragraph (g)(2)(v) of this section are labeled as follows:

DANGER: CLOTHING AND EQUIPMENT CONTAMINATED WITH LEAD. MAY DAMAGE FERTILITY OR THE UNBORN CHILD. CAUSES DAMAGE TO THE CENTRAL NERVOUS SYSTEM. DO NOT EAT, DRINK OR SMOKE WHEN HANDLING. DO NOT REMOVE DUST BY BLOWING OR SHAKING. DISPOSE OF LEAD CONTAMINATED WASH WATER IN ACCORDANCE WITH APPLICABLE LOCAL, STATE, OR FEDERAL REGULATIONS.

(B) Prior to June 1, 2015, employers may include the following information on bags or containers of contaminated protective clothing and equipment required by paragraph (g)(2)(v) in lieu of the labeling requirements in paragraph (g)(2)(vii)(A) of this section:

Caution: Clothing contaminated with lead. Do not remove dust by blowing or shaking. Dispose of lead contaminated wash water in accordance with applicable local, state, or federal regulations.

(viii) The employer shall prohibit the removal of lead from protective clothing or equipment by blowing, shaking, or any other means which disperses lead into the air.

(h) *Housekeeping*—(1) All surfaces shall be maintained as free as practicable of accumulations of lead.

(2) Clean-up of floors and other surfaces where lead accumulates shall wherever possible, be cleaned by vacuuming or other methods that minimize the likelihood of lead becoming airborne.

(3) Shoveling, dry or wet sweeping, and brushing may be used only where vacuuming or other equally effective methods have been tried and found not to be effective.

(4) Where vacuuming methods are selected, the vacuums shall be equipped with HEPA filters and used and emptied in a manner which minimizes the reentry of lead into the workplace.

(5) Compressed air shall not be used to remove lead from any surface unless the compressed air is used in conjunction with a ventilation system designed to capture the airborne dust created by the compressed air.

(i) *Hygiene facilities and practices.* (1) The employer shall assure that in areas where employees are exposed to lead above the PEL without regard to the use of respirators, food or beverage is not present or consumed, tobacco products are not present or used, and cosmetics are not applied.

(2) *Change areas.* (i) The employer shall provide clean change areas for employees whose airborne exposure to lead is above the PEL, and as interim protection for employees performing tasks as specified in paragraph (d)(2) of this section, without regard to the use of respirators.

(ii) The employer shall assure that change areas are equipped with separate storage facilities for protective work clothing and equipment and for street clothes which prevent cross-contamination.

(iii) The employer shall assure that employees do not leave the workplace wearing any protective clothing or equipment that is required to be worn during the work shift.

(3) *Showers.* (i) The employer shall provide shower facilities, where feasible, for use by employees whose airborne exposure to lead is above the PEL.

(ii) The employer shall assure, where shower facilities are available, that employees shower at the end of the work shift and shall provide an adequate supply of cleansing agents and towels for use by affected employees.

(4) *Eating facilities.* (i) The employer shall provide lunchroom facilities or eating areas for employees whose airborne exposure to lead is above the PEL, without regard to the use of respirators.

(ii) The employer shall assure that lunchroom facilities or eating areas are as free as practicable from lead contamination and are readily accessible to employees.

(iii) The employer shall assure that employees whose airborne exposure to lead is above the PEL, without regard to the use of a respirator, wash their hands and face prior to eating, drinking, smoking or applying cosmetics.

(iv) The employer shall assure that employees do not enter lunchroom facilities or eating areas with protective work clothing or equipment unless surface lead dust has been removed by vacuuming, downdraft booth, or other cleaning method that limits dispersion of lead dust.

(5) *Hand washing facilities.* (i) The employer shall provide adequate handwashing facilities for use by employees exposed to lead in accordance with 29 CFR 1926.51(f).

(ii) Where showers are not provided the employer shall assure that employees wash their hands and face at the end of the work-shift.

(j) *Medical surveillance—(1) General.* (i) The employer shall make available initial medical surveillance to employees occupationally exposed on any day to lead at or above the action level. Initial medical surveillance consists of biological monitoring in the form of blood sampling and analysis for lead and zinc protoporphyrin levels.

(ii) The employer shall institute a medical surveillance program in accordance with paragraphs (j)(2) and (j)(3) of this section for all employees who are or may be exposed by the employer at or above the action level for more than 30 days in any consecutive 12 months;

(iii) The employer shall assure that all medical examinations and procedures are performed by or under the supervision of a licensed physician.

(iv) The employer shall make available the required medical surveillance including multiple physician review under paragraph (j)(3)(iii) without cost to employees and at a reasonable time and place.

(2) *Biological monitoring—(i) Blood lead and ZPP level sampling and analysis.* The employer shall make available biological monitoring in the form of blood sampling and analysis for lead and zinc protoporphyrin levels to each employee covered under paragraphs (j)(1)(i) and (ii) of this section on the following schedule:

(A) For each employee covered under paragraph (j)(1)(ii) of this section, at least every 2 months for the first 6 months and every 6 months thereafter;

(B) For each employee covered under paragraphs (j)(1) (i) or (ii) of this section whose last blood sampling and analysis indicated a blood lead level at or above 40 µg/dl, at least every two months. This frequency shall continue until two consecutive blood samples and analyses indicate a blood lead level below 40 µg/dl; and

(C) For each employee who is removed from exposure to lead due to an elevated blood lead level at least monthly during the removal period.

(ii) *Follow-up blood sampling tests.* Whenever the results of a blood lead level test indicate that an employee's blood lead level is at or above the numerical criterion for medical removal under paragraph (k)(1)(i) of this section, the employer shall provide a second (follow-up) blood sampling test within two weeks after the employer receives the results of the first blood sampling test.

(iii) *Accuracy of blood lead level sampling and analysis.* Blood lead level sampling and analysis provided pursuant to this section shall have an accuracy (to a confidence level of 95 percent) within plus or minus 15 percent or 6 µg/dl, whichever is greater, and shall be conducted by a laboratory approved by OSHA.

(iv) *Employee notification.* (A) Within five working days after the receipt of biological monitoring results, the employer shall notify each employee in writing of his or her blood lead level; and

(B) The employer shall notify each employee whose blood lead level is at or above 40 µg/dl that the standard requires temporary medical removal with Medical Removal Protection benefits when an employee's blood lead level is at or above the numerical criterion for medical removal under paragraph (k)(1)(i) of this section.

(3) *Medical examinations and consultations—(i) Frequency.* The employer shall make available medical examinations and consultations to each employee covered under paragraph (j)(1)(ii) of this section on the following schedule:

(A) At least annually for each employee for whom a blood sampling test conducted at any time during the preceding 12 months indicated a blood lead level at or above 40 µg/dl;

(B) As soon as possible, upon notification by an employee either that the employee has developed signs or symptoms commonly associated with lead intoxication, that the employee desires medical advice concerning the effects of current or past exposure to lead on the employee's ability to procreate a healthy child, that the employee is pregnant, or that the employee has demonstrated difficulty in breathing during a respirator fitting test or during use; and

(C) As medically appropriate for each employee either removed from exposure to lead due to a risk of sustaining material impairment to health, or otherwise limited pursuant to a final medical determination.

(ii) *Content.* The content of medical examinations made available pursuant to paragraph (j)(3)(i)(B)-(C) of this section shall be determined by an examining physician and, if requested by an employee, shall include pregnancy testing or laboratory evaluation of male fertility. Medical examinations made available pursuant to paragraph (j)(3)(i)(A) of this section shall include the following elements:

(A) A detailed work history and a medical history, with particular attention to past lead exposure (occupational and non-occupational), personal habits (smoking, hygiene), and past gastrointestinal, hematologic, renal, cardiovascular, reproductive and neurological problems;

(B) A thorough physical examination, with particular attention to teeth, gums, hematologic, gastrointestinal, renal, cardiovascular, and neurological systems. Pulmonary status should be evaluated if respiratory protection will be used;

(C) A blood pressure measurement;

(D) A blood sample and analysis which determines:

(1) Blood lead level;

(2) Hemoglobin and hematocrit determinations, red cell indices, and examination of peripheral smear morphology;

(3) Zinc protoporphyrin;

(4) Blood urea nitrogen; and,

(5) Serum creatinine;

(E) A routine urinalysis with microscopic examination; and

(F) Any laboratory or other test relevant to lead exposure which the examining physician deems necessary by sound medical practice.

(iii) *Multiple physician review mechanism.* (A) If the employer selects the initial physician who conducts any medical examination or consultation provided to an employee under this section, the employee may designate a second physician:

(1) To review any findings, determinations or recommendations of the initial physician; and

(2) To conduct such examinations, consultations, and laboratory tests as the second physician deems necessary to facilitate this review.

(B) The employer shall promptly notify an employee of the right to seek a second medical opinion after each occasion that an initial physician conducts a medical examination or consultation pursuant to this section. The employer may condition its participation in, and payment for, the multiple physician review mechanism upon the employee doing the following within fifteen (15) days after receipt of the foregoing notification, or receipt of the initial physician's written opinion, whichever is later:

(1) The employee informing the employer that he or she intends to seek a second medical opinion, and

(2) The employee initiating steps to make an appointment with a second physician.

(C) If the findings, determinations or recommendations of the second physician differ from those of the initial physician, then the employer and the employee shall assure that efforts are made for the two physicians to resolve any disagreement.

(D) If the two physicians have been unable to quickly resolve their disagreement, then the employer and the employee through their respective physicians shall designate a third physician:

(1) To review any findings, determinations or recommendations of the prior physicians; and

(2) To conduct such examinations, consultations, laboratory tests and discussions with the prior physicians as the third physician deems necessary to resolve the disagreement of the prior physicians.

(E) The employer shall act consistent with the findings, determinations and recommendations of the third physician, unless the employer and the employee reach an agreement which is otherwise consistent with the recommendations of at least one of the three physicians.

(iv) *Information provided to examining and consulting physicians.* (A) The employer shall provide an initial physician conducting a medical examination or consultation under this section with the following information:

(1) A copy of this regulation for lead including all Appendices;

(2) A description of the affected employee's duties as they relate to the employee's exposure;

(3) The employee's exposure level or anticipated exposure level to lead and to any other toxic substance (if applicable);

(4) A description of any personal protective equipment used or to be used;

(5) Prior blood lead determinations; and

(6) All prior written medical opinions concerning the employee in the employer's possession or control.

(B) The employer shall provide the foregoing information to a second or third physician conducting a medical examination or consultation under this section upon request either by the second or third physician, or by the employee.

(v) *Written medical opinions.* (A) The employer shall obtain and furnish the employee with a copy of a written medical opinion from each examining or consulting physician which contains only the following information:

(1) The physician's opinion as to whether the employee has any detected medical condition which would place the employee at increased risk of material impairment of the employee's health from exposure to lead;

(2) Any recommended special protective measures to be provided to the employee, or limitations to be placed upon the employee's exposure to lead;

(3) Any recommended limitation upon the employee's use of respirators, including a determination of whether the employee can wear a powered air purifying respirator if a physician determines that the employee cannot wear a negative pressure respirator; and

(4) The results of the blood lead determinations.

(B) The employer shall instruct each examining and consulting physician to:

(1) Not reveal either in the written opinion or orally, or in any other means of communication with the employer, findings, including laboratory results, or diagnoses unrelated to an employee's occupational exposure to lead; and

(2) Advise the employee of any medical condition, occupational or nonoccupational, which dictates further medical examination or treatment.

(vi) *Alternate physician determination mechanisms.* The employer and an employee or authorized employee representative may agree upon the use of any alternate physician determination mechanism in lieu of the multiple physician review mechanism provided by paragraph (j)(3)(iii) of this section so long as the alternate mechanism is as expeditious and protective as the requirements contained in this paragraph.

(4) *Chelation.* (i) The employer shall assure that any person whom he retains, employs, supervises or controls does not engage in prophylactic chelation of any employee at any time.

(ii) If therapeutic or diagnostic chelation is to be performed by any person in paragraph (j)(4)(i) of this section, the employer shall assure that it be done under the supervision of a licensed physician in a clinical setting with thorough and appropriate medical monitoring and that the employee is notified in writing prior to its occurrence.

(k) *Medical removal protection—(1) Temporary medical removal and return of an employee—(i) Temporary removal due to elevated blood lead level.* The employer shall remove an employee from work having an exposure to lead at or above the action level on each occasion that a periodic and a follow-up blood sampling test conducted pursuant to this section indicate that the employee's blood lead level is at or above 50 µg/dl; and,

(ii) *Temporary removal due to a final medical determination.* (A) The employer shall remove an employee from work having an exposure to lead at or above the action level on each occasion that a final medical determination results in a medical finding, determination, or opinion that the employee has a detected medical condition which places the employee at increased risk of material impairment to health from exposure to lead.

(B) For the purposes of this section, the phrase *final medical determination* means the written medical opinion on the employees' health status by the examining physician or, where relevant, the outcome of the multiple physician review mechanism or alternate medical determination mechanism used pursuant to the medical surveillance provisions of this section.

(C) Where a final medical determination results in any recommended special protective measures for an employee, or limitations on an employee's exposure to lead, the employer shall implement and act consistent with the recommendation.

(iii) *Return of the employee to former job status.* (A) The employer shall return an employee to his or her former job status:

(1) For an employee removed due to a blood lead level at or above 50 µg/dl when two consecutive blood sampling tests indicate that the employee's blood lead level is below 40 µg/dl;

(2) For an employee removed due to a final medical determination, when a subsequent final medical determination results in a medical finding, determination, or opinion that the employee no longer has a detected medical condition which places the employee at increased risk of material impairment to health from exposure to lead.

(B) For the purposes of this section, the requirement that an employer return an employee to his or her former job status is not intended to expand upon or restrict any rights an employee has or would have had, absent temporary medical removal, to a specific job classification or position under the terms of a collective bargaining agreement.

(iv) *Removal of other employee special protective measure or limitations.* The employer shall remove any limitations placed on an employee or end any special protective measures provided to an employee pursuant to a final medical determination when a subsequent final medical determination indicates that the limitations or special protective measures are no longer necessary.

(v) *Employer options pending a final medical determination.* Where the multiple physician review mechanism, or alternate medical determination mechanism used pursuant to the medical surveillance provisions of this section, has not yet resulted in a final medical determination with respect to an employee, the employer shall act as follows:

(A) *Removal.* The employer may remove the employee from exposure to lead, provide special protective measures to the employee, or place limitations upon the employee, consistent with the medical findings, determinations, or recommendations of any of the physicians who have reviewed the employee's health status.

(B) *Return.* The employer may return the employee to his or her former job status, end any special protective measures provided to the employee, and remove any limitations placed upon the employee, consistent with the medical findings, determinations, or recommendations of any of the physicians who have reviewed the employee's health status, with two exceptions.

(1) If the initial removal, special protection, or limitation of the employee resulted from a final medical determination which differed from the findings, determinations, or recommendations of the initial physician or;

(2) If the employee has been on removal status for the preceding eighteen months due to an elevated blood lead level, then the employer shall await a final medical determination.

(2) *Medical removal protection benefits—(i) Provision of medical removal protection benefits.* The employer shall provide an employee up to eighteen (18) months of medical removal protection benefits on each occasion that an employee is removed from exposure to lead or otherwise limited pursuant to this section.

(ii) *Definition of medical removal protection benefits.* For the purposes of this section, the requirement that an employer provide medical removal protection benefits means that, as long as

the job the employee was removed from continues, the employer shall maintain the total normal earnings, seniority and other employment rights and benefits of an employee, including the employee's right to his or her former job status as though the employee had not been medically removed from the employee's job or otherwise medically limited.

(iii) *Follow-up medical surveillance during the period of employee removal or limitation.* During the period of time that an employee is medically removed from his or her job or otherwise medically limited, the employer may condition the provision of medical removal protection benefits upon the employee's participation in follow-up medical surveillance made available pursuant to this section.

(iv) *Workers' compensation claims.* If a removed employee files a claim for workers' compensation payments for a lead-related disability, then the employer shall continue to provide medical removal protection benefits pending disposition of the claim. To the extent that an award is made to the employee for earnings lost during the period of removal, the employer's medical removal protection obligation shall be reduced by such amount. The employer shall receive no credit for workers' compensation payments received by the employee for treatment-related expenses.

(v) *Other credits.* The employer's obligation to provide medical removal protection benefits to a removed employee shall be reduced to the extent that the employee receives compensation for earnings lost during the period of removal either from a publicly or employer-funded compensation program, or receives income from employment with another employer made possible by virtue of the employee's removal.

(vi) *Voluntary removal or restriction of an employee.* Where an employer, although not required by this section to do so, removes an employee from exposure to lead or otherwise places limitations on an employee due to the effects of lead exposure on the employee's medical condition, the employer shall provide medical removal protection benefits to the employee equal to that required by paragraph (k)(2) (i) and (ii) of this section.

(l) *Communication of hazards—(1) General—(i) Hazard communication.* The employer shall include lead in the program established to comply with the Hazard Communication Standard (HCS) (§1910.1200). The employer shall ensure that each employee has access to labels on containers of lead and safety data sheets, and is trained in accordance with the provisions of HCS and paragraph (l) of this section. The employer shall ensure that at least the following hazards are addressed:

- (A) Reproductive/developmental toxicity;
- (B) Central nervous system effects;
- (C) Kidney effects;
- (D) Blood effects; and
- (E) Acute toxicity effects.

(ii) The employer shall train each employee who is subject to exposure to lead at or above the action level on any day, or who is subject to exposure to lead compounds which may cause skin or eye irritation (*e.g.*, lead arsenate, lead azide), in accordance with the requirements of this section. The employer shall institute a training program and ensure employee participation in the program.

(iii) The employer shall provide the training program as initial training prior to the time of job assignment or prior to the start up date for this requirement, whichever comes last.

(iv) The employer shall also provide the training program at least annually for each employee who is subject to lead exposure at or above the action level on any day.

(2) *Training program.* The employer shall assure that each employee is trained in the following:

(i) The content of this standard and its appendices;

(ii) The specific nature of the operations which could result in exposure to lead above the action level;

(iii) The purpose, proper selection, fitting, use, and limitations of respirators;

(iv) The purpose and a description of the medical surveillance program, and the medical removal protection program including information concerning the adverse health effects associated with excessive exposure to lead (with particular attention to the adverse reproductive effects on both males and females and hazards to the fetus and additional precautions for employees who are pregnant);

(v) The engineering controls and work practices associated with the employee's job assignment including training of employees to follow relevant good work practices described in appendix B of this section;

(vi) The contents of any compliance plan in effect;

(vii) Instructions to employees that chelating agents should not routinely be used to remove lead from their bodies and should not be used at all except under the direction of a licensed physician; and

(viii) The employee's right of access to records under 29 CFR 1910.20.

(3) *Access to information and training materials.* (i) The employer shall make readily available to all affected employees a copy of this standard and its appendices.

(ii) The employer shall provide, upon request, all materials relating to the employee information and training program to affected employees and their designated representatives, and to the Assistant Secretary and the Director.

(m) *Signs—(1) General.* (i) The employer shall post the following warning signs in each workarea where an employee's exposure to lead is above the PEL.

DANGER

LEAD WORK AREA

MAY DAMAGE FERTILITY OR THE UNBORN CHILD

CAUSES DAMAGE TO THE CENTRAL NERVOUS SYSTEM

DO NOT EAT, DRINK OR SMOKE IN THIS AREA

(ii) The employer shall ensure that no statement appears on or near any sign required by this paragraph (m) that contradicts or detracts from the meaning of the required sign.

(iii) The employer shall ensure that signs required by this paragraph (m) are illuminated and cleaned as necessary so that the legend is readily visible.

(iv) The employer may use signs required by other statutes, regulations or ordinances in addition to, or in combination with, signs required by this paragraph (m).

(v) Prior to June 1, 2016, employers may use the following legend in lieu of that specified in paragraph (m)(1)(i) of this section:

WARNING

LEAD WORK AREA

POISON

NO SMOKING OR EATING

(n) *Recordkeeping—(1) Exposure assessment.* (i) The employer shall establish and maintain an accurate record of all monitoring and other data used in conducting employee exposure assessments as required in paragraph (d) of this section.

(ii) Exposure monitoring records shall include:

(A) The date(s), number, duration, location and results of each of the samples taken if any, including a description of the sampling procedure used to determine representative employee exposure where applicable;

(B) A description of the sampling and analytical methods used and evidence of their accuracy;

(C) The type of respiratory protective devices worn, if any;

(D) Name and job classification of the employee monitored and of all other employees whose exposure the measurement is intended to represent; and

(E) The environmental variables that could affect the measurement of employee exposure.

(iii) The employer shall maintain monitoring and other exposure assessment records in accordance with the provisions of 29 CFR 1910.33.

(2) *Medical surveillance.* (i) The employer shall establish and maintain an accurate record for each employee subject to medical surveillance as required by paragraph (j) of this section.

(ii) This record shall include:

(A) The name and description of the duties of the employee;

(B) A copy of the physician's written opinions;

(C) Results of any airborne exposure monitoring done on or for that employee and provided to the physician; and

(D) Any employee medical complaints related to exposure to lead.

(iii) The employer shall keep, or assure that the examining physician keeps, the following medical records:

(A) A copy of the medical examination results including medical and work history required under paragraph (j) of this section;

(B) A description of the laboratory procedures and a copy of any standards or guidelines used to interpret the test results or references to that information;

(C) A copy of the results of biological monitoring.

(iv) The employer shall maintain or assure that the physician maintains medical records in accordance with the provisions of 29 CFR 1910.33.

(3) *Medical removals.* (i) The employer shall establish and maintain an accurate record for each employee removed from current exposure to lead pursuant to paragraph (k) of this section.

(ii) Each record shall include:

(A) The name of the employee;

(B) The date of each occasion that the employee was removed from current exposure to lead as well as the corresponding date on which the employee was returned to his or her former job status;

(C) A brief explanation of how each removal was or is being accomplished; and

(D) A statement with respect to each removal indicating whether or not the reason for the removal was an elevated blood lead level.

(iii) The employer shall maintain each medical removal record for at least the duration of an employee's employment.

(4) *Objective data for exemption from requirement for initial monitoring.* (i) For purposes of this section, objective data are information demonstrating that a particular product or material containing lead or a specific process, operation, or activity involving lead cannot release dust or fumes in concentrations at or above the action level under any expected conditions of use. Objective data can be obtained from an industry-wide study or from laboratory product test results from manufacturers of lead containing products or materials. The data the employer uses from an industry-wide survey must be obtained under workplace conditions closely resembling the processes, types of material, control methods, work practices and environmental conditions in the employer's current operations.

(ii) The employer shall maintain the record of the objective data relied upon for at least 30 years.

(5) *Availability.* The employer shall make available upon request all records required to be maintained by paragraph (n) of this section to affected employees, former employees, and their designated representatives, and to the Assistant Secretary and the Director for examination and copying.

(6) *Transfer of records.* (i) Whenever the employer ceases to do business, the successor employer shall receive and retain all records required to be maintained by paragraph (n) of this section.

(ii) The employer shall also comply with any additional requirements involving the transfer of records set forth in 29 CFR 1910.1020(h).

(o) *Observation of monitoring—(1) Employee observation.* The employer shall provide affected employees or their designated representatives an opportunity to observe any monitoring of employee exposure to lead conducted pursuant to paragraph (d) of this section.

(2) *Observation procedures.* (i) Whenever observation of the monitoring of employee exposure to lead requires entry into an area where the use of respirators, protective clothing or equipment is required, the employer shall provide the observer with and assure the use of such respirators, clothing and equipment, and shall require the observer to comply with all other applicable safety and health procedures.

(ii) Without interfering with the monitoring, observers shall be entitled to:

(A) Receive an explanation of the measurement procedures;

(B) Observe all steps related to the monitoring of lead performed at the place of exposure; and

(C) Record the results obtained or receive copies of the results when returned by the laboratory.

(p) *Appendices.* The information contained in the appendices to this section is not intended by itself, to create any additional obligations not otherwise imposed by this standard nor detract from any existing obligation.

## APPENDIX A TO §1926.62—SUBSTANCE DATA SHEET FOR OCCUPATIONAL EXPOSURE TO LEAD

### *I. Substance Identification*

A. *Substance:* Pure lead (Pb) is a heavy metal at room temperature and pressure and is a basic chemical element. It can combine with various other substances to form numerous lead compounds.

B. *Compounds covered by the standard:* The word *lead* when used in this interim final standard means elemental lead, all inorganic lead compounds and a class of organic lead compounds called lead soaps. This standard does not apply to other organic lead compounds.

C. *Uses:* Exposure to lead occurs in several different occupations in the construction industry, including demolition or salvage of structures where lead or lead-containing materials are present; removal or encapsulation of lead-containing materials, new construction, alteration, repair, or renovation of structures that contain lead or materials containing lead; installation of products containing lead. In addition, there are construction related activities where exposure to lead may occur, including transportation, disposal, storage, or containment of lead or materials containing lead on construction sites, and maintenance operations associated with construction activities.

D. *Permissible exposure:* The permissible exposure limit (PEL) set by the standard is 50 micrograms of lead per cubic meter of air ( $50 \mu\text{g}/\text{m}^3$ ), averaged over an 8-hour workday.

E. *Action level:* The interim final standard establishes an action level of 30 micrograms of lead per cubic meter of air ( $30 \mu\text{g}/\text{m}^3$ ), averaged over an 8-hour workday. The action level triggers several ancillary provisions of the standard such as exposure monitoring, medical surveillance, and training.

### *II. Health Hazard Data*

A. *Ways in which lead enters your body.* When absorbed into your body in certain doses, lead is a toxic substance. The object of the lead standard is to prevent absorption of harmful quantities of lead. The standard is intended to protect you not only from the immediate toxic effects of lead, but also from the serious toxic effects that may not become apparent until years of exposure have passed. Lead can be absorbed into your body by inhalation (breathing) and ingestion (eating). Lead (except for certain organic lead compounds not covered by the standard, such as tetraethyl lead) is not absorbed through your skin. When lead is scattered in the air as a dust, fume respiratory tract. Inhalation of airborne lead is generally the most important source of occupational lead absorption. You can also absorb lead through your digestive system if lead gets into your mouth and is swallowed. If you handle food, cigarettes, chewing tobacco, or make-up which have lead on them or handle them with hands contaminated with lead, this will contribute to ingestion. A significant portion of the lead that you inhale or ingest gets into your blood stream. Once in your bloodstream, lead is circulated throughout your body and stored in various organs and body tissues. Some of this lead is quickly filtered out of your body and excreted, but some remains in the blood and other

tissues. As exposure to lead continues, the amount stored in your body will increase if you are absorbing more lead than your body is excreting. Even though you may not be aware of any immediate symptoms of disease, this lead stored in your tissues can be slowly causing irreversible damage, first to individual cells, then to your organs and whole body systems.

B. *Effects of overexposure to lead*—(1) *Short term (acute) overexposure*. Lead is a potent, systemic poison that serves no known useful function once absorbed by your body. Taken in large enough doses, lead can kill you in a matter of days. A condition affecting the brain called acute encephalopathy may arise which develops quickly to seizures, coma, and death from cardiorespiratory arrest. A short term dose of lead can lead to acute encephalopathy. Short term occupational exposures of this magnitude are highly unusual, but not impossible. Similar forms of encephalopathy may, however, arise from extended, chronic exposure to lower doses of lead. There is no sharp dividing line between rapidly developing acute effects of lead, and chronic effects which take longer to acquire. Lead adversely affects numerous body systems, and causes forms of health impairment and disease which arise after periods of exposure as short as days or as long as several years.

(2) *Long-term (chronic) overexposure*. Chronic overexposure to lead may result in severe damage to your blood-forming, nervous, urinary and reproductive systems. Some common symptoms of chronic overexposure include loss of appetite, metallic taste in the mouth, anxiety, constipation, nausea, pallor, excessive tiredness, weakness, insomnia, headache, nervous irritability, muscle and joint pain or soreness, fine tremors, numbness, dizziness, hyperactivity and colic. In lead colic there may be severe abdominal pain. Damage to the central nervous system in general and the brain (encephalopathy) in particular is one of the most severe forms of lead poisoning. The most severe, often fatal, form of encephalopathy may be preceded by vomiting, a feeling of dullness progressing to drowsiness and stupor, poor memory, restlessness, irritability, tremor, and convulsions. It may arise suddenly with the onset of seizures, followed by coma, and death. There is a tendency for muscular weakness to develop at the same time. This weakness may progress to paralysis often observed as a characteristic “wrist drop” or “foot drop” and is a manifestation of a disease to the nervous system called peripheral neuropathy. Chronic overexposure to lead also results in kidney disease with few, if any, symptoms appearing until extensive and most likely permanent kidney damage has occurred. Routine laboratory tests reveal the presence of this kidney disease only after about two-thirds of kidney function is lost. When overt symptoms of urinary dysfunction arise, it is often too late to correct or prevent worsening conditions, and progression to kidney dialysis or death is possible. Chronic overexposure to lead impairs the reproductive systems of both men and women. Overexposure to lead may result in decreased sex drive, impotence and sterility in men. Lead can alter the structure of sperm cells raising the risk of birth defects. There is evidence of miscarriage and stillbirth in women whose husbands were exposed to lead or who were exposed to lead themselves. Lead exposure also may result in decreased fertility, and abnormal menstrual cycles in women. The course of pregnancy may be adversely affected by exposure to lead since lead crosses the placental barrier and poses risks to developing fetuses. Children born of parents either one of whom were exposed to excess lead levels are more likely to have birth defects, mental retardation, behavioral disorders or die during the first year of childhood. Overexposure to lead also disrupts the blood-forming system resulting in decreased hemoglobin (the substance in the blood that carries oxygen to the cells) and ultimately anemia. Anemia is characterized by weakness, pallor and fatigability as a result of decreased oxygen carrying capacity in the blood.

(3) *Health protection goals of the standard.* Prevention of adverse health effects for most workers from exposure to lead throughout a working lifetime requires that a worker's blood lead level (BLL, also expressed as PbB) be maintained at or below forty micrograms per deciliter of whole blood (40 µg/dl). The blood lead levels of workers (both male and female workers) who intend to have children should be maintained below 30 µg/dl to minimize adverse reproductive health effects to the parents and to the developing fetus. The measurement of your blood lead level (BLL) is the most useful indicator of the amount of lead being absorbed by your body. Blood lead levels are most often reported in units of milligrams (mg) or micrograms (µg) of lead (1 mg = 1000 µg) per 100 grams (100g), 100 milliliters (100 ml) or deciliter (dl) of blood. These three units are essentially the same. Sometime BLLs are expressed in the form of mg% or µg%. This is a shorthand notation for 100g, 100 ml, or dl. (References to BLL measurements in this standard are expressed in the form of µg/dl.)

BLL measurements show the amount of lead circulating in your blood stream, but do not give any information about the amount of lead stored in your various tissues. BLL measurements merely show current absorption of lead, not the effect that lead is having on your body or the effects that past lead exposure may have already caused. Past research into lead-related diseases, however, has focused heavily on associations between BLLs and various diseases. As a result, your BLL is an important indicator of the likelihood that you will gradually acquire a lead-related health impairment or disease.

Once your blood lead level climbs above 40 µg/dl, your risk of disease increases. There is a wide variability of individual response to lead, thus it is difficult to say that a particular BLL in a given person will cause a particular effect. Studies have associated fatal encephalopathy with BLLs as low as 150 µg/dl. Other studies have shown other forms of diseases in some workers with BLLs well below 80 µg/dl. Your BLL is a crucial indicator of the risks to your health, but one other factor is also extremely important. This factor is the length of time you have had elevated BLLs. The longer you have an elevated BLL, the greater the risk that large quantities of lead are being gradually stored in your organs and tissues (body burden). The greater your overall body burden, the greater the chances of substantial permanent damage. The best way to prevent all forms of lead-related impairments and diseases—both short term and long term—is to maintain your BLL below 40 µg/dl. The provisions of the standard are designed with this end in mind.

Your employer has prime responsibility to assure that the provisions of the standard are complied with both by the company and by individual workers. You, as a worker, however, also have a responsibility to assist your employer in complying with the standard. You can play a key role in protecting your own health by learning about the lead hazards and their control, learning what the standard requires, following the standard where it governs your own actions, and seeing that your employer complies with provisions governing his or her actions.

(4) *Reporting signs and symptoms of health problems.* You should immediately notify your employer if you develop signs or symptoms associated with lead poisoning or if you desire medical advice concerning the effects of current or past exposure to lead or your ability to have a healthy child. You should also notify your employer if you have difficulty breathing during a respirator fit test or while wearing a respirator. In each of these cases, your employer must make available to you appropriate medical examinations or consultations. These must be provided at no cost to you and at a reasonable time and place. The standard contains a procedure whereby you can obtain a second opinion by a physician of your choice if your employer selected the initial physician.

## APPENDIX B TO §1926.62—EMPLOYEE STANDARD SUMMARY

This appendix summarizes key provisions of the interim final standard for lead in construction that you as a worker should become familiar with.

### *I. Permissible Exposure Limit (PEL)—Paragraph (C)*

The standard sets a permissible exposure limit (PEL) of 50 micrograms of lead per cubic meter of air ( $50 \mu\text{g}/\text{m}^3$ ), averaged over an 8-hour workday which is referred to as a time-weighted average (TWA). This is the highest level of lead in air to which you may be permissibly exposed over an 8-hour workday. However, since this is an 8-hour average, short exposures above the PEL are permitted so long as for each 8-hour work day your average exposure does not exceed this level. This interim final standard, however, takes into account the fact that your daily exposure to lead can extend beyond a typical 8-hour workday as the result of overtime or other alterations in your work schedule. To deal with this situation, the standard contains a formula which reduces your permissible exposure when you are exposed more than 8 hours. For example, if you are exposed to lead for 10 hours a day, the maximum permitted average exposure would be  $40 \mu\text{g}/\text{m}^3$ .

### *II. Exposure Assessment—Paragraph (D)*

If lead is present in your workplace in any quantity, your employer is required to make an initial determination of whether any employee's exposure to lead exceeds the action level ( $30 \mu\text{g}/\text{m}^3$  averaged over an 8-hour day). Employee exposure is that exposure which would occur if the employee were not using a respirator. This initial determination requires your employer to monitor workers' exposures unless he or she has objective data which can demonstrate conclusively that no employee will be exposed to lead in excess of the action level. Where objective data is used in lieu of actual monitoring the employer must establish and maintain an accurate record, documenting its relevancy in assessing exposure levels for current job conditions. If such objective data is available, the employer need proceed no further on employee exposure assessment until such time that conditions have changed and the determination is no longer valid.

Objective data may be compiled from various sources, e.g., insurance companies and trade associations and information from suppliers or exposure data collected from similar operations. Objective data may also comprise previously-collected sampling data including area monitoring. If it cannot be determined through using objective data that worker exposure is less than the action level, your employer must conduct monitoring or must rely on relevant previous personal sampling, if available. Where monitoring is required for the initial determination, it may be limited to a representative number of employees who are reasonably expected to have the highest exposure levels. If your employer has conducted appropriate air sampling for lead in the past 12 months, he or she may use these results, provided they are applicable to the same employee tasks and exposure conditions and meet the requirements for accuracy as specified in the standard. As with objective data, if such results are relied upon for the initial determination, your employer must establish and maintain a record as to the relevancy of such data to current job conditions.

If there have been any employee complaints of symptoms which may be attributable to exposure to lead or if there is any other information or observations which would indicate employee exposure to lead, this must also be considered as part of the initial determination.

If this initial determination shows that a reasonable possibility exists that any employee may be exposed, without regard to respirators, over the action level, your employer must set up an air monitoring program to determine the exposure level representative of each employee exposed to lead at your workplace. In carrying out this air monitoring program, your employer is not required to monitor the exposure of every employee, but he or she must monitor a representative number of employees and job types. Enough sampling must be done to enable each employee's exposure level to be reasonably represent full shift exposure. In addition, these air samples must be taken under conditions which represent each employee's regular, daily exposure to lead. Sampling performed in the past 12 months may be used to determine exposures above the action level if such sampling was conducted during work activities essentially similar to present work conditions.

The standard lists certain tasks which may likely result in exposures to lead in excess of the PEL and, in some cases, exposures in excess of 50 times the PEL. If you are performing any of these tasks, your employer must provide you with appropriate respiratory protection, protective clothing and equipment, change areas, hand washing facilities, biological monitoring, and training until such time that an exposure assessment is conducted which demonstrates that your exposure level is below the PEL.

If you are exposed to lead and air sampling is performed, your employer is required to notify you in writing within 5 working days of the air monitoring results which represent your exposure. If the results indicate that your exposure exceeds the PEL (without regard to your use of a respirator), then your employer must also notify you of this in writing, and provide you with a description of the corrective action that has been taken or will be taken to reduce your exposure.

Your exposure must be rechecked by monitoring, at least every six months if your exposure is at or over the action level but below the PEL. Your employer may discontinue monitoring for you if 2 consecutive measurements, taken at least 7 days apart, are at or below the action level. Air monitoring must be repeated every 3 months if you are exposed over the PEL. Your employer must continue monitoring for you at this frequency until 2 consecutive measurements, taken at least 7 days apart, are below the PEL but above the action level, at which time your employer must repeat monitoring of your exposure every six months and may discontinue monitoring only after your exposure drops to or below the action level. However, whenever there is a change of equipment, process, control, or personnel or a new type of job is added at your workplace which may result in new or additional exposure to lead, your employer must perform additional monitoring.

### *III. Methods of Compliance—Paragraph (E)*

Your employer is required to assure that no employee is exposed to lead in excess of the PEL as an 8-hour TWA. The interim final standard for lead in construction requires employers to institute engineering and work practice controls including administrative controls to the extent feasible to reduce employee exposure to lead. Where such controls are feasible but not adequate to reduce exposures below the PEL they must be used nonetheless to reduce exposures to the lowest level that can be accomplished by these means and then supplemented with appropriate respiratory protection.

Your employer is required to develop and implement a written compliance program prior to the commencement of any job where employee exposures may reach the PEL as an 8-hour TWA.

The interim final standard identifies the various elements that must be included in the plan. For example, employers are required to include a description of operations in which lead is emitted, detailing other relevant information about the operation such as the type of equipment used, the type of material involved, employee job responsibilities, operating procedures and maintenance practices. In addition, your employer's compliance plan must specify the means that will be used to achieve compliance and, where engineering controls are required, include any engineering plans or studies that have been used to select the control methods. If administrative controls involving job rotation are used to reduce employee exposure to lead, the job rotation schedule must be included in the compliance plan. The plan must also detail the type of protective clothing and equipment, including respirators, housekeeping and hygiene practices that will be used to protect you from the adverse effects of exposure to lead.

The written compliance program must be made available, upon request, to affected employees and their designated representatives, the Assistant Secretary and the Director.

Finally, the plan must be reviewed and updated at least every 6 months to assure it reflects the current status in exposure control.

#### IV. RESPIRATORY PROTECTION—PARAGRAPH (F)

Your employer is required to provide and assure your use of respirators when your exposure to lead is not controlled below the PEL by other means. The employer must pay the cost of the respirator. Whenever you request one, your employer is also required to provide you a respirator even if your air exposure level is not above the PEL. You might desire a respirator when, for example, you have received medical advice that your lead absorption should be decreased. Or, you may intend to have children in the near future, and want to reduce the level of lead in your body to minimize adverse reproductive effects. While respirators are the least satisfactory means of controlling your exposure, they are capable of providing significant protection if properly chosen, fitted, worn, cleaned, maintained, and replaced when they stop providing adequate protection.

Your employer is required to select your respirator according to the requirements of 29 CFR 1926.62(f)(3), including the requirements referenced in 29 CFR 1910.134(d)(3)(i)(A) of this chapter. Any respirator chosen must be approved by NIOSH under the provisions of 42 CFR part 84. These respirator selection references will enable your employer to choose a type of respirator that will give you a proper amount of protection based on your airborne lead exposure. Your employer may select a type of respirator that provides greater protection than that required by the standard; that is, one recommended for a higher concentration of lead than is present in your workplace. For example, a powered air-purifying respirator (PAPR) is much more protective than a typical negative pressure respirator, and may also be more comfortable to wear. A PAPR has a filter, cartridge, or canister to clean the air, and a power source that continuously blows filtered air into your breathing zone. Your employer might make a PAPR available to you to ease the burden of having to wear a respirator for long periods of time. The standard provides that you can obtain a PAPR upon request.

Your employer must also start a Respiratory Protection Program. This program must include written procedures for the proper selection, use, cleaning, storage, and maintenance of respirators.

Your employer must ensure that your respirator facepiece fits properly. Proper fit of a respirator facepiece is critical to your protection from airborne lead. Obtaining a proper fit on each employee may require your employer to make available several different types of respirator masks. To ensure that your respirator fits properly and that facepiece leakage is minimal, your employer must give you either a qualitative or quantitative fit test as specified in appendix A of the Respiratory Protection standard located at 29 CFR 1910.134.

You must also receive from your employer proper training in the use of respirators. Your employer is required to teach you how to wear a respirator, to know why it is needed, and to understand its limitations.

The standard provides that if your respirator uses filter elements, you must be given an opportunity to change the filter elements whenever an increase in breathing resistance is detected. You also must be permitted to periodically leave your work area to wash your face and respirator facepiece whenever necessary to prevent skin irritation. If you ever have difficulty in breathing during a fit test or while using a respirator, your employer must make a medical examination available to you to determine whether you can safely wear a respirator. The result of this examination may be to give you a positive pressure respirator (which reduces breathing resistance) or to provide alternative means of protection.

#### *V. Protective Work Clothing and Equipment—Paragraph (G)*

If you are exposed to lead above the PEL as an 8-hour TWA, without regard to your use of a respirator, or if you are exposed to lead compounds such as lead arsenate or lead azide which can cause skin and eye irritation, your employer must provide you with protective work clothing and equipment appropriate for the hazard. If work clothing is provided, it must be provided in a clean and dry condition at least weekly, and daily if your airborne exposure to lead is greater than 200  $\mu\text{g}/\text{m}^3$ . Appropriate protective work clothing and equipment can include coveralls or similar full-body work clothing, gloves, hats, shoes or disposable shoe coverlets, and face shields or vented goggles. Your employer is required to provide all such equipment at no cost to you. In addition, your employer is responsible for providing repairs and replacement as necessary, and also is responsible for the cleaning, laundering or disposal of protective clothing and equipment.

The interim final standard requires that your employer assure that you follow good work practices when you are working in areas where your exposure to lead may exceed the PEL. With respect to protective clothing and equipment, where appropriate, the following procedures should be observed prior to beginning work:

1. Change into work clothing and shoe covers in the clean section of the designated changing areas;
2. Use work garments of appropriate protective gear, including respirators before entering the work area; and
3. Store any clothing not worn under protective clothing in the designated changing area.

Workers should follow these procedures upon leaving the work area:

1. HEPA vacuum heavily contaminated protective work clothing while it is still being worn. At no time may lead be removed from protective clothing by any means which result in uncontrolled dispersal of lead into the air;

2. Remove shoe covers and leave them in the work area;

3. Remove protective clothing and gear in the dirty area of the designated changing area. Remove protective coveralls by carefully rolling down the garment to reduce exposure to dust.

4. Remove respirators last; and

5. Wash hands and face.

Workers should follow these procedures upon finishing work for the day (in addition to procedures described above):

1. Where applicable, place disposal coveralls and shoe covers with the abatement waste;

2. Contaminated clothing which is to be cleaned, laundered or disposed of must be placed in closed containers in the change room.

3. Clean protective gear, including respirators, according to standard procedures;

4. Wash hands and face again. If showers are available, take a shower and wash hair. If shower facilities are not available at the work site, shower immediately at home and wash hair.

#### *VI. Housekeeping—Paragraph (H)*

Your employer must establish a housekeeping program sufficient to maintain all surfaces as free as practicable of accumulations of lead dust. Vacuuming is the preferred method of meeting this requirement, and the use of compressed air to clean floors and other surfaces is generally prohibited unless removal with compressed air is done in conjunction with ventilation systems designed to contain dispersal of the lead dust. Dry or wet sweeping, shoveling, or brushing may not be used except where vacuuming or other equally effective methods have been tried and do not work. Vacuums must be used equipped with a special filter called a high-efficiency particulate air (HEPA) filter and emptied in a manner which minimizes the reentry of lead into the workplace.

#### *VII. Hygiene Facilities and Practices—Paragraph (I)*

The standard requires that hand washing facilities be provided where occupational exposure to lead occurs. In addition, change areas, showers (where feasible), and lunchrooms or eating areas are to be made available to workers exposed to lead above the PEL. Your employer must assure that except in these facilities, food and beverage is not present or consumed, tobacco products are not present or used, and cosmetics are not applied, where airborne exposures are above the PEL. Change rooms provided by your employer must be equipped with separate storage facilities for your protective clothing and equipment and street clothes to avoid cross-contamination. After showering, no required protective clothing or equipment worn during the shift may be worn home.

It is important that contaminated clothing or equipment be removed in change areas and not be worn home or you will extend your exposure and expose your family since lead from your clothing can accumulate in your house, car, etc.

Lunchrooms or eating areas may not be entered with protective clothing or equipment unless surface dust has been removed by vacuuming, downdraft booth, or other cleaning method. Finally, workers exposed above the PEL must wash both their hands and faces prior to eating, drinking, smoking or applying cosmetics.

All of the facilities and hygiene practices just discussed are essential to minimize additional sources of lead absorption from inhalation or ingestion of lead that may accumulate on you, your clothes, or your possessions. Strict compliance with these provisions can virtually eliminate several sources of lead exposure which significantly contribute to excessive lead absorption.

#### *VIII. Medical Surveillance—Paragraph (j)*

The medical surveillance program is part of the standard's comprehensive approach to the prevention of lead-related disease. Its purpose is to supplement the main thrust of the standard which is aimed at minimizing airborne concentrations of lead and sources of ingestion. Only medical surveillance can determine if the other provisions of the standard have affectively protected you as an individual. Compliance with the standard's provision will protect most workers from the adverse effects of lead exposure, but may not be satisfactory to protect individual workers (1) who have high body burdens of lead acquired over past years, (2) who have additional uncontrolled sources of non-occupational lead exposure, (3) who exhibit unusual variations in lead absorption rates, or (4) who have specific non-work related medical conditions which could be aggravated by lead exposure (e.g., renal disease, anemia). In addition, control systems may fail, or hygiene and respirator programs may be inadequate. Periodic medical surveillance of individual workers will help detect those failures. Medical surveillance will also be important to protect your reproductive ability—regardless of whether you are a man or woman.

All medical surveillance required by the interim final standard must be performed by or under the supervision of a licensed physician. The employer must provide required medical surveillance without cost to employees and at a reasonable time and place. The standard's medical surveillance program has two parts—periodic biological monitoring and medical examinations. Your employer's obligation to offer you medical surveillance is triggered by the results of the air monitoring program. Full medical surveillance must be made available to all employees who are or may be exposed to lead in excess of the action level for more than 30 days a year and whose blood lead level exceeds 40 µg/dl. Initial medical surveillance consisting of blood sampling and analysis for lead and zinc protoporphyrin must be provided to all employees exposed at any time (1 day) above the action level.

Biological monitoring under the standard must be provided at least every 2 months for the first 6 months and every 6 months thereafter until your blood lead level is below 40 µg/dl. A zinc protoporphyrin (ZPP) test is a very useful blood test which measures an adverse metabolic effect of lead on your body and is therefore an indicator of lead toxicity.

If your BLL exceeds 40 µg/dl the monitoring frequency must be increased from every 6 months to at least every 2 months and not reduced until two consecutive BLLs indicate a blood lead level below 40 µg/dl. Each time your BLL is determined to be over 40 µg/dl, your employer must notify you of this in writing within five working days of his or her receipt of the test results. The employer must also inform you that the standard requires temporary medical removal with economic protection when your BLL exceeds 50 µg/dl. (See Discussion of Medical Removal Protection- Paragraph (k).) Anytime your BLL exceeds 50 µg/dl your employer must make available to you within two weeks of receipt of these test results a second follow-up BLL test to confirm your BLL. If the two tests both exceed 50 µg/dl, and you are temporarily removed, then your employer must make successive BLL tests available to you on a monthly basis during the period of your removal.

Medical examinations beyond the initial one must be made available on an annual basis if your blood lead level exceeds 40 µg/dl at any time during the preceding year and you are being exposed above the airborne action level of 30 µg/m<sup>3</sup> for 30 or more days per year. The initial examination will provide information to establish a baseline to which subsequent data can be compared.

An initial medical examination to consist of blood sampling and analysis for lead and zinc protoporphyrin must also be made available (prior to assignment) for each employee being assigned for the first time to an area where the airborne concentration of lead equals or exceeds the action level at any time. In addition, a medical examination or consultation must be made available as soon as possible if you notify your employer that you are experiencing signs or symptoms commonly associated with lead poisoning or that you have difficulty breathing while wearing a respirator or during a respirator fit test. You must also be provided a medical examination or consultation if you notify your employer that you desire medical advice concerning the effects of current or past exposure to lead on your ability to procreate a healthy child.

Finally, appropriate follow-up medical examinations or consultations may also be provided for employees who have been temporarily removed from exposure under the medical removal protection provisions of the standard. (See Part IX, below.)

The standard specifies the minimum content of pre-assignment and annual medical examinations. The content of other types of medical examinations and consultations is left up to the sound discretion of the examining physician. Pre-assignment and annual medical examinations must include (1) a detailed work history and medical history; (2) a thorough physical examination, including an evaluation of your pulmonary status if you will be required to use a respirator; (3) a blood pressure measurement; and (4) a series of laboratory tests designed to check your blood chemistry and your kidney function. In addition, at any time upon your request, a laboratory evaluation of male fertility will be made (microscopic examination of a sperm sample), or a pregnancy test will be given.

The standard does not require that you participate in any of the medical procedures, tests, etc. which your employer is required to make available to you. Medical surveillance can, however, play a very important role in protecting your health. You are strongly encouraged, therefore, to participate in a meaningful fashion. The standard contains a multiple physician review mechanism which will give you a chance to have a physician of your choice directly participate in the medical surveillance program. If you are dissatisfied with an examination by a physician chosen by your employer, you can select a second physician to conduct an independent analysis. The two doctors would attempt

to resolve any differences of opinion, and select a third physician to resolve any firm dispute. Generally your employer will choose the physician who conducts medical surveillance under the lead standard-unless you and your employer can agree on the choice of a physician or physicians. Some companies and unions have agreed in advance, for example, to use certain independent medical laboratories or panels of physicians. Any of these arrangements are acceptable so long as required medical surveillance is made available to workers.

The standard requires your employer to provide certain information to a physician to aid in his or her examination of you. This information includes (1) the standard and its appendices, (2) a description of your duties as they relate to occupational lead exposure, (3) your exposure level or anticipated exposure level, (4) a description of any personal protective equipment you wear, (5) prior blood lead level results, and (6) prior written medical opinions concerning you that the employer has. After a medical examination or consultation the physician must prepare a written report which must contain (1) the physician's opinion as to whether you have any medical condition which places you at increased risk of material impairment to health from exposure to lead, (2) any recommended special protective measures to be provided to you, (3) any blood lead level determinations, and (4) any recommended limitation on your use of respirators. This last element must include a determination of whether you can wear a powered air purifying respirator (PAPR) if you are found unable to wear a negative pressure respirator.

The medical surveillance program of the interim lead standard may at some point in time serve to notify certain workers that they have acquired a disease or other adverse medical condition as a result of occupational lead exposure. If this is true, these workers might have legal rights to compensation from public agencies, their employers, firms that supply hazardous products to their employers, or other persons. Some states have laws, including worker compensation laws, that disallow a worker who learns of a job-related health impairment to sue, unless the worker sues within a short period of time after learning of the impairment. (This period of time may be a matter of months or years.) An attorney can be consulted about these possibilities. It should be stressed that OSHA is in no way trying to either encourage or discourage claims or lawsuits. However, since results of the standard's medical surveillance program can significantly affect the legal remedies of a worker who has acquired a job-related disease or impairment, it is proper for OSHA to make you aware of this.

The medical surveillance section of the standard also contains provisions dealing with chelation. Chelation is the use of certain drugs (administered in pill form or injected into the body) to reduce the amount of lead absorbed in body tissues. Experience accumulated by the medical and scientific communities has largely confirmed the effectiveness of this type of therapy for the treatment of very severe lead poisoning. On the other hand, it has also been established that there can be a long list of extremely harmful side effects associated with the use of chelating agents. The medical community has balanced the advantages and disadvantages resulting from the use of chelating agents in various circumstances and has established when the use of these agents is acceptable. The standard includes these accepted limitations due to a history of abuse of chelation therapy by some lead companies. The most widely used chelating agents are calcium disodium EDTA, (Ca Na<sub>2</sub> EDTA), Calcium Disodium Versenate (Versenate), and d-penicillamine (pencillamine or Cupramine).

The standard prohibits “prophylactic chelation” of any employee by any person the employer retains, supervises or controls. *Prophylactic chelation* is the routine use of chelating or similarly acting drugs to prevent elevated blood levels in workers who are occupationally exposed to lead, or the use of these drugs to routinely lower blood lead levels to predesignated concentrations believed to be “safe”. It should be emphasized that where an employer takes a worker who has no symptoms of lead poisoning and has chelation carried out by a physician (either inside or outside of a hospital) solely to reduce the worker's blood lead level, that will generally be considered prophylactic chelation. The use of a hospital and a physician does not mean that prophylactic chelation is not being performed. Routine chelation to prevent increased or reduce current blood lead levels is unacceptable whatever the setting.

The standard allows the use of “therapeutic” or “diagnostic” chelation if administered under the supervision of a licensed physician in a clinical setting with thorough and appropriate medical monitoring. Therapeutic chelation responds to severe lead poisoning where there are marked symptoms. Diagnostic chelation involved giving a patient a dose of the drug then collecting all urine excreted for some period of time as an aid to the diagnosis of lead poisoning.

In cases where the examining physician determines that chelation is appropriate, you must be notified in writing of this fact before such treatment. This will inform you of a potentially harmful treatment, and allow you to obtain a second opinion.

#### *IX. Medical Removal Protection—Paragraph (K)*

Excessive lead absorption subjects you to increased risk of disease. Medical removal protection (MRP) is a means of protecting you when, for whatever reasons, other methods, such as engineering controls, work practices, and respirators, have failed to provide the protection you need. MRP involves the temporary removal of a worker from his or her regular job to a place of significantly lower exposure without any loss of earnings, seniority, or other employment rights or benefits. The purpose of this program is to cease further lead absorption and allow your body to naturally excrete lead which has previously been absorbed. Temporary medical removal can result from an elevated blood lead level, or a medical opinion. For up to 18 months, or for as long as the job the employee was removed from lasts, protection is provided as a result of either form of removal. The vast majority of removed workers, however, will return to their former jobs long before this eighteen month period expires.

You may also be removed from exposure even if your blood lead level is below 50 µg/dl if a final medical determination indicates that you temporarily need reduced lead exposure for medical reasons. If the physician who is implementing your employers medical program makes a final written opinion recommending your removal or other special protective measures, your employer must implement the physician's recommendation. If you are removed in this manner, you may only be returned when the doctor indicates that it is safe for you to do so.

The standard does not give specific instructions dealing with what an employer must do with a removed worker. Your job assignment upon removal is a matter for you, your employer and your union (if any) to work out consistent with existing procedures for job assignments. Each removal must be accomplished in a manner consistent with existing collective bargaining relationships. Your employer is given broad discretion to implement temporary removals so long as no attempt is made

to override existing agreements. Similarly, a removed worker is provided no right to veto an employer's choice which satisfies the standard.

In most cases, employers will likely transfer removed employees to other jobs with sufficiently low lead exposure. Alternatively, a worker's hours may be reduced so that the time weighted average exposure is reduced, or he or she may be temporarily laid off if no other alternative is feasible.

In all of these situation, MRP benefits must be provided during the period of removal—i.e., you continue to receive the same earnings, seniority, and other rights and benefits you would have had if you had not been removed. Earnings includes more than just your base wage; it includes overtime, shift differentials, incentives, and other compensation you would have earned if you had not been removed. During the period of removal you must also be provided with appropriate follow-up medical surveillance. If you were removed because your blood lead level was too high, you must be provided with a monthly blood test. If a medical opinion caused your removal, you must be provided medical tests or examinations that the doctor believes to be appropriate. If you do not participate in this follow up medical surveillance, you may lose your eligibility for MRP benefits.

When you are medically eligible to return to your former job, your employer must return you to your "former job status." This means that you are entitled to the position, wages, benefits, etc., you would have had if you had not been removed. If you would still be in your old job if no removal had occurred that is where you go back. If not, you are returned consistent with whatever job assignment discretion your employer would have had if no removal had occurred. MRP only seeks to maintain your rights, not expand them or diminish them.

If you are removed under MRP and you are also eligible for worker compensation or other compensation for lost wages, your employer's MRP benefits obligation is reduced by the amount that you actually receive from these other sources. This is also true if you obtain other employment during the time you are laid off with MRP benefits.

The standard also covers situations where an employer voluntarily removes a worker from exposure to lead due to the effects of lead on the employee's medical condition, even though the standard does not require removal. In these situations MRP benefits must still be provided as though the standard required removal. Finally, it is important to note that in all cases where removal is required, respirators cannot be used as a substitute. Respirators may be used before removal becomes necessary, but not as an alternative to a transfer to a low exposure job, or to a lay-off with MRP benefits.

#### *X. Employee Information and Training—Paragraph (L)*

Your employer is required to provide an information and training program for all employees exposed to lead above the action level or who may suffer skin or eye irritation from lead compounds such as lead arsenate or lead azide. The program must train these employees regarding the specific hazards associated with their work environment, protective measures which can be taken, including the contents of any compliance plan in effect, the danger of lead to their bodies (including their reproductive systems), and their rights under the standard. All employees must be trained prior to initial assignment to areas where there is a possibility of exposure over the action level.

This training program must also be provided at least annually thereafter unless further exposure above the action level will not occur.

*XI. Signs—Paragraph (M)*

The standard requires that the following warning sign be posted in work areas when the exposure to lead is above the PEL:

DANGER

LEAD WORK AREA

MAY DAMAGE FERTILITY OR THE UNBORN CHILD

CAUSES DAMAGE TO THE CENTRAL NERVOUS SYSTEM

DO NOT EAT, DRINK OR SMOKE IN THIS AREA

Prior to June 1, 2016, employers may use the following legend in lieu of that specified above:

WARNING

LEAD WORK AREA

POISON

NO SMOKING OR EATING

*XII. Recordkeeping—Paragraph (N)*

Your employer is required to keep all records of exposure monitoring for airborne lead. These records must include the name and job classification of employees measured, details of the sampling and analytical techniques, the results of this sampling, and the type of respiratory protection being worn by the person sampled. Such records are to be retained for at least 30 years. Your employer is also required to keep all records of biological monitoring and medical examination results. These records must include the names of the employees, the physician's written opinion, and a copy of the results of the examination. Medical records must be preserved and maintained for the duration of employment plus 30 years. However, if the employee's duration of employment is less than one year, the employer need not retain that employee's medical records beyond the period of employment if they are provided to the employee upon termination of employment.

Recordkeeping is also required if you are temporarily removed from your job under the medical removal protection program. This record must include your name, the date of your removal and return, how the removal was or is being accomplished, and whether or not the reason for the removal was an elevated blood lead level. Your employer is required to keep each medical removal record only for as long as the duration of an employee's employment.

The standard requires that if you request to see or copy environmental monitoring, blood lead level monitoring, or medical removal records, they must be made available to you or to a

representative that you authorize. Your union also has access to these records. Medical records other than BLL's must also be provided upon request to you, to your physician or to any other person whom you may specifically designate. Your union does not have access to your personal medical records unless you authorize their access.

### *XIII. Observation of Monitoring—Paragraph (O)*

When air monitoring for lead is performed at your workplace as required by this standard, your employer must allow you or someone you designate to act as an observer of the monitoring. Observers are entitled to an explanation of the measurement procedure, and to record the results obtained. Since results will not normally be available at the time of the monitoring, observers are entitled to record or receive the results of the monitoring when returned by the laboratory. Your employer is required to provide the observer with any personal protective devices required to be worn by employees working in the area that is being monitored. The employer must require the observer to wear all such equipment and to comply with all other applicable safety and health procedures.

### *XIV. For Additional Information*

A. A copy of the interim standard for lead in construction can be obtained free of charge by calling or writing the OSHA Office of Publications, room N-3101, United States Department of Labor, Washington, DC 20210: Telephone (202) 219-4667.

B. Additional information about the standard, its enforcement, and your employer's compliance can be obtained from the nearest OSHA Area Office listed in your telephone directory under United States Government/Department of Labor.

## APPENDIX C TO §1926.62—MEDICAL SURVEILLANCE GUIDELINES

### *Introduction*

The primary purpose of the Occupational Safety and Health Act of 1970 is to assure, so far as possible, safe and healthful working conditions for every working man and woman. The interim final occupational health standard for lead in construction is designed to protect workers exposed to inorganic lead including metallic lead, all inorganic lead compounds and organic lead soaps.

Under this interim final standard occupational exposure to inorganic lead is to be limited to 50  $\mu\text{g}/\text{m}^3$  (micrograms per cubic meter) based on an 8 hour time-weighted average (TWA). This permissible exposure limit (PEL) must be achieved through a combination of engineering, work practice and administrative controls to the extent feasible. Where these controls are in place but are found not to reduce employee exposures to or below the PEL, they must be used nonetheless, and supplemented with respirators to meet the 50  $\mu\text{g}/\text{m}^3$  exposure limit.

The standard also provides for a program of biological monitoring for employees exposed to lead above the action level at any time, and additional medical surveillance for all employees exposed to levels of inorganic lead above 30  $\mu\text{g}/\text{m}^3$  (TWA) for more than 30 days per year and whose BLL exceeds 40  $\mu\text{g}/\text{dl}$ .

The purpose of this document is to outline the medical surveillance provisions of the interim standard for inorganic lead in construction, and to provide further information to the physician regarding the examination and evaluation of workers exposed to inorganic lead.

Section 1 provides a detailed description of the monitoring procedure including the required frequency of blood testing for exposed workers, provisions for medical removal protection (MRP), the recommended right of the employee to a second medical opinion, and notification and recordkeeping requirements of the employer. A discussion of the requirements for respirator use and respirator monitoring and OSHA's position on prophylactic chelation therapy are also included in this section.

Section 2 discusses the toxic effects and clinical manifestations of lead poisoning and effects of lead intoxication on enzymatic pathways in heme synthesis. The adverse effects on both male and female reproductive capacity and on the fetus are also discussed.

Section 3 outlines the recommended medical evaluation of the worker exposed to inorganic lead, including details of the medical history, physical examination, and recommended laboratory tests, which are based on the toxic effects of lead as discussed in Section 2.

Section 4 provides detailed information concerning the laboratory tests available for the monitoring of exposed workers. Included also is a discussion of the relative value of each test and the limitations and precautions which are necessary in the interpretation of the laboratory results.

#### *1. Medical Surveillance and Monitoring Requirements for Workers Exposed to Inorganic Lead*

Under the interim final standard for inorganic lead in the construction industry, initial medical surveillance consisting of biological monitoring to include blood lead and ZPP level determination shall be provided to employees exposed to lead at or above the action level on any one day. In addition, a program of biological monitoring is to be made available to all employees exposed above the action level at any time and additional medical surveillance is to be made available to all employees exposed to lead above  $30 \mu\text{g}/\text{m}^3$  TWA for more than 30 days each year and whose BLL exceeds  $40 \mu\text{g}/\text{dl}$ . This program consists of periodic blood sampling and medical evaluation to be performed on a schedule which is defined by previous laboratory results, worker complaints or concerns, and the clinical assessment of the examining physician.

Under this program, the blood lead level (BLL) of all employees who are exposed to lead above  $30 \mu\text{g}/\text{m}^3$  for more than 30 days per year or whose blood lead is above  $40 \mu\text{g}/\text{dl}$  but exposed for no more than 30 days per year is to be determined at least every two months for the first six months of exposure and every six months thereafter. The frequency is increased to every two months for employees whose last blood lead level was  $40 \mu\text{g}/\text{dl}$  or above. For employees who are removed from exposure to lead due to an elevated blood lead, a new blood lead level must be measured monthly. A zinc protoporphyrin (ZPP) measurement is strongly recommended on each occasion that a blood lead level measurement is made.

An annual medical examination and consultation performed under the guidelines discussed in Section 3 is to be made available to each employee exposed above  $30 \mu\text{g}/\text{m}^3$  for more than 30 days per year for whom a blood test conducted at any time during the preceding 12 months indicated a

blood lead level at or above 40 µg/dl. Also, an examination is to be given to all employees prior to their assignment to an area in which airborne lead concentrations reach or exceed the 30 µg/m<sup>3</sup> for more than 30 days per year. In addition, a medical examination must be provided as soon as possible after notification by an employee that the employee has developed signs or symptoms commonly associated with lead intoxication, that the employee desires medical advice regarding lead exposure and the ability to procreate a healthy child, or that the employee has demonstrated difficulty in breathing during a respirator fitting test or during respirator use. An examination is also to be made available to each employee removed from exposure to lead due to a risk of sustaining material impairment to health, or otherwise limited or specially protected pursuant to medical recommendations.

Results of biological monitoring or the recommendations of an examining physician may necessitate removal of an employee from further lead exposure pursuant to the standard's medical removal protection (MRP) program. The object of the MRP program is to provide temporary medical removal to workers either with substantially elevated blood lead levels or otherwise at risk of sustaining material health impairment from continued substantial exposure to lead.

Under the standard's ultimate worker removal criteria, a worker is to be removed from any work having an eight hour TWA exposure to lead of 30 µg/m<sup>3</sup> when his or her blood lead level reaches 50 µg/dl and is confirmed by a second follow-up blood lead level performed within two weeks after the employer receives the results of the first blood sampling test. Return of the employee to his or her job status depends on a worker's blood lead level declining to 40 µg/dl.

As part of the interim standard, the employer is required to notify in writing each employee whose blood lead level exceeds 40 µg/dl. In addition each such employee is to be informed that the standard requires medical removal with MRP benefits, discussed below, when an employee's blood lead level exceeds the above defined limit.

In addition to the above blood lead level criterion, temporary worker removal may also take place as a result of medical determinations and recommendations. Written medical opinions must be prepared after each examination pursuant to the standard. If the examining physician includes a medical finding, determination or opinion that the employee has a medical condition which places the employee at increased risk of material health impairment from exposure to lead, then the employee must be removed from exposure to lead at or above 30 µg/m<sup>3</sup>. Alternatively, if the examining physician recommends special protective measures for an employee (e.g., use of a powered air purifying respirator) or recommends limitations on an employee's exposure to lead, then the employer must implement these recommendations.

Recommendations may be more stringent than the specific provisions of the standard. The examining physician, therefore, is given broad flexibility to tailor special protective procedures to the needs of individual employees. This flexibility extends to the evaluation and management of pregnant workers and male and female workers who are planning to raise children. Based on the history, physical examination, and laboratory studies, the physician might recommend special protective measures or medical removal for an employee who is pregnant or who is planning to conceive a child when, in the physician's judgment, continued exposure to lead at the current job would pose a significant risk. The return of the employee to his or her former job status, or the removal of special protections or limitations, depends upon the examining physician determining

that the employee is no longer at increased risk of material impairment or that special measures are no longer needed.

During the period of any form of special protection or removal, the employer must maintain the worker's earnings, seniority, and other employment rights and benefits (as though the worker had not been removed) for a period of up to 18 months or for as long as the job the employee was removed from lasts if less than 18 months. This economic protection will maximize meaningful worker participation in the medical surveillance program, and is appropriate as part of the employer's overall obligation to provide a safe and healthful workplace. The provisions of MRP benefits during the employee's removal period may, however, be conditioned upon participation in medical surveillance.

The lead standard provides for a multiple physician review in cases where the employee wishes a second opinion concerning potential lead poisoning or toxicity. If an employee wishes a second opinion, he or she can make an appointment with a physician of his or her choice. This second physician will review the findings, recommendations or determinations of the first physician and conduct any examinations, consultations or tests deemed necessary in an attempt to make a final medical determination. If the first and second physicians do not agree in their assessment they must try to resolve their differences. If they cannot reach an agreement then they must designate a third physician to resolve the dispute.

The employer must provide examining and consulting physicians with the following specific information: A copy of the lead regulations and all appendices, a description of the employee's duties as related to exposure, the exposure level or anticipated level to lead and any other toxic substances (if applicable), a description of personal protective equipment used, blood lead levels, and all prior written medical opinions regarding the employee in the employer's possession or control. The employer must also obtain from the physician and provide the employee with a written medical opinion containing blood lead levels, the physicians's opinion as to whether the employee is at risk of material impairment to health, any recommended protective measures for the employee if further exposure is permitted, as well as any recommended limitations upon an employee's use of respirators.

Employers must instruct each physician not to reveal to the employer in writing or in any other way his or her findings, laboratory results, or diagnoses which are felt to be unrelated to occupational lead exposure. They must also instruct each physician to advise the employee of any occupationally or non-occupationally related medical condition requiring further treatment or evaluation.

The standard provides for the use of respirators where engineering and other primary controls are not effective. However, the use of respirator protection shall not be used in lieu of temporary medical removal due to elevated blood lead levels or findings that an employee is at risk of material health impairment. This is based on the numerous inadequacies of respirators including skin rash where the facepiece makes contact with the skin, unacceptable stress to breathing in some workers with underlying cardiopulmonary impairment, difficulty in providing adequate fit, the tendency for respirators to create additional hazards by interfering with vision, hearing, and mobility, and the difficulties of assuring the maximum effectiveness of a complicated work practice program involving respirators. Respirators do, however, serve a useful function where engineering and work practice

controls are inadequate by providing supplementary, interim, or short-term protection, provided they are properly selected for the environment in which the employee will be working, properly fitted to the employee, maintained and cleaned periodically, and worn by the employee when required.

In its interim final standard on occupational exposure to inorganic lead in the construction industry, OSHA has prohibited prophylactic chelation. Diagnostic and therapeutic chelation are permitted only under the supervision of a licensed physician with appropriate medical monitoring in an acceptable clinical setting. The decision to initiate chelation therapy must be made on an individual basis and take into account the severity of symptoms felt to be a result of lead toxicity along with blood lead levels, ZPP levels, and other laboratory tests as appropriate. EDTA and penicillamine which are the primary chelating agents used in the therapy of occupational lead poisoning have significant potential side effects and their use must be justified on the basis of expected benefits to the worker. Unless frank and severe symptoms are present, therapeutic chelation is not recommended, given the opportunity to remove a worker from exposure and allow the body to naturally excrete accumulated lead. As a diagnostic aid, the chelation mobilization test using CA-EDTA has limited applicability. According to some investigators, the test can differentiate between lead-induced and other nephropathies. The test may also provide an estimation of the mobile fraction of the total body lead burden.

Employers are required to assure that accurate records are maintained on exposure assessment, including environmental monitoring, medical surveillance, and medical removal for each employee. Exposure assessment records must be kept for at least 30 years. Medical surveillance records must be kept for the duration of employment plus 30 years except in cases where the employment was less than one year. If duration of employment is less than one year, the employer need not retain this record beyond the term of employment if the record is provided to the employee upon termination of employment. Medical removal records also must be maintained for the duration of employment. All records required under the standard must be made available upon request to the Assistant Secretary of Labor for Occupational Safety and Health and the Director of the National Institute for Occupational Safety and Health. Employers must also make environmental and biological monitoring and medical removal records available to affected employees and to former employees or their authorized employee representatives. Employees or their specifically designated representatives have access to their entire medical surveillance records.

In addition, the standard requires that the employer inform all workers exposed to lead at or above  $30 \mu\text{g}/\text{m}^3$  of the provisions of the standard and all its appendices, the purpose and description of medical surveillance and provisions for medical removal protection if temporary removal is required. An understanding of the potential health effects of lead exposure by all exposed employees along with full understanding of their rights under the lead standard is essential for an effective monitoring program.

## *II. Adverse Health Effects of Inorganic Lead*

Although the toxicity of lead has been known for 2,000 years, the knowledge of the complex relationship between lead exposure and human response is still being refined. Significant research into the toxic properties of lead continues throughout the world, and it should be anticipated that our understanding of thresholds of effects and margins of safety will be improved in future years.

The provisions of the lead standard are founded on two prime medical judgments: First, the prevention of adverse health effects from exposure to lead throughout a working lifetime requires that worker blood lead levels be maintained at or below 40 µg/dl and second, the blood lead levels of workers, male or female, who intend to parent in the near future should be maintained below 30 µg/dl to minimize adverse reproductive health effects to the parents and developing fetus. The adverse effects of lead on reproduction are being actively researched and OSHA encourages the physician to remain abreast of recent developments in the area to best advise pregnant workers or workers planning to conceive children.

The spectrum of health effects caused by lead exposure can be subdivided into five developmental stages: Normal, physiological changes of uncertain significance, pathophysiological changes, overt symptoms (morbidity), and mortality. Within this process there are no sharp distinctions, but rather a continuum of effects. Boundaries between categories overlap due to the wide variation of individual responses and exposures in the working population. OSHA's development of the lead standard focused on pathophysiological changes as well as later stages of disease.

1. Heme Synthesis Inhibition. The earliest demonstrated effect of lead involves its ability to inhibit at least two enzymes of the heme synthesis pathway at very low blood levels. Inhibition of delta aminolevulinic acid dehydrase (ALA-D) which catalyzes the conversion of delta-aminolevulinic acid (ALA) to protoporphyrin is observed at a blood lead level below 20 µg/dl. At a blood lead level of 40 µg/dl, more than 20% of the population would have 70% inhibition of ALA-D. There is an exponential increase in ALA excretion at blood lead levels greater than 40 µg/dl.

Another enzyme, ferrochelatase, is also inhibited at low blood lead levels. Inhibition of ferrochelatase leads to increased free erythrocyte protoporphyrin (FEP) in the blood which can then bind to zinc to yield zinc protoporphyrin. At a blood lead level of 50 µg/dl or greater, nearly 100% of the population will have an increase in FEP. There is also an exponential relationship between blood lead levels greater than 40 µg/dl and the associated ZPP level, which has led to the development of the ZPP screening test for lead exposure.

While the significance of these effects is subject to debate, it is OSHA's position that these enzyme disturbances are early stages of a disease process which may eventually result in the clinical symptoms of lead poisoning. Whether or not the effects do progress to the later stages of clinical disease, disruption of these enzyme processes over a working lifetime is considered to be a material impairment of health.

One of the eventual results of lead-induced inhibition of enzymes in the heme synthesis pathway is anemia which can be asymptomatic if mild but associated with a wide array of symptoms including dizziness, fatigue, and tachycardia when more severe. Studies have indicated that lead levels as low as 50 µg/dl can be associated with a definite decreased hemoglobin, although most cases of lead-induced anemia, as well as shortened red-cell survival times, occur at lead levels exceeding 80 µg/dl. Inhibited hemoglobin synthesis is more common in chronic cases whereas shortened erythrocyte life span is more common in acute cases.

In lead-induced anemias, there is usually a reticulocytosis along with the presence of basophilic stippling, and ringed sideroblasts, although none of the above are pathognomonic for lead-induced anemia.

2. Neurological Effects. Inorganic lead has been found to have toxic effects on both the central and peripheral nervous systems. The earliest stages of lead-induced central nervous system effects first manifest themselves in the form of behavioral disturbances and central nervous system symptoms including irritability, restlessness, insomnia and other sleep disturbances, fatigue, vertigo, headache, poor memory, tremor, depression, and apathy. With more severe exposure, symptoms can progress to drowsiness, stupor, hallucinations, delirium, convulsions and coma.

The most severe and acute form of lead poisoning which usually follows ingestion or inhalation of large amounts of lead is acute encephalopathy which may arise precipitously with the onset of intractable seizures, coma, cardiorespiratory arrest, and death within 48 hours.

While there is disagreement about what exposure levels are needed to produce the earliest symptoms, most experts agree that symptoms definitely can occur at blood lead levels of 60  $\mu\text{g}/\text{dl}$  whole blood and therefore recommend a 40  $\mu\text{g}/\text{dl}$  maximum. The central nervous system effects frequently are not reversible following discontinued exposure or chelation therapy and when improvement does occur, it is almost always only partial.

The peripheral neuropathy resulting from lead exposure characteristically involves only motor function with minimal sensory damage and has a marked predilection for the extensor muscles of the most active extremity. The peripheral neuropathy can occur with varying degrees of severity. The earliest and mildest form which can be detected in workers with blood lead levels as low as 50  $\mu\text{g}/\text{dl}$  is manifested by slowing of motor nerve conduction velocity often without clinical symptoms. With progression of the neuropathy there is development of painless extensor muscle weakness usually involving the extensor muscles of the fingers and hand in the most active upper extremity, followed in severe cases by wrist drop or, much less commonly, foot drop.

In addition to slowing of nerve conduction, electromyographical studies in patients with blood lead levels greater than 50  $\mu\text{g}/\text{dl}$  have demonstrated a decrease in the number of acting motor unit potentials, an increase in the duration of motor unit potentials, and spontaneous pathological activity including fibrillations and fasciculations. Whether these effects occur at levels of 40  $\mu\text{g}/\text{dl}$  is undetermined.

While the peripheral neuropathies can occasionally be reversed with therapy, again such recovery is not assured particularly in the more severe neuropathies and often improvement is only partial. The lack of reversibility is felt to be due in part to segmental demyelination.

3. Gastrointestinal. Lead may also affect the gastrointestinal system producing abdominal colic or diffuse abdominal pain, constipation, obstipation, diarrhea, anorexia, nausea and vomiting. Lead colic rarely develops at blood lead levels below 80  $\mu\text{g}/\text{dl}$ .

4. Renal. Renal toxicity represents one of the most serious health effects of lead poisoning. In the early stages of disease nuclear inclusion bodies can frequently be identified in proximal renal tubular cells. Renal function remains normal and the changes in this stage are probably reversible.

With more advanced disease there is progressive interstitial fibrosis and impaired renal function. Eventually extensive interstitial fibrosis ensues with sclerotic glomeruli and dilated and atrophied proximal tubules; all represent end stage kidney disease. Azotemia can be progressive, eventually resulting in frank uremia necessitating dialysis. There is occasionally associated hypertension and hyperuricemia with or without gout.

Early kidney disease is difficult to detect. The urinalysis is normal in early lead nephropathy and the blood urea nitrogen and serum creatinine increase only when two-thirds of kidney function is lost. Measurement of creatinine clearance can often detect earlier disease as can other methods of measurement of glomerular filtration rate. An abnormal Ca-EDTA mobilization test has been used to differentiate between lead-induced and other nephropathies, but this procedure is not widely accepted. A form of Fanconi syndrome with aminoaciduria, glycosuria, and hyperphosphaturia indicating severe injury to the proximal renal tubules is occasionally seen in children.

5. Reproductive effects. Exposure to lead can have serious effects on reproductive function in both males and females. In male workers exposed to lead there can be a decrease in sexual drive, impotence, decreased ability to produce healthy sperm, and sterility. Malformed sperm (teratospermia), decreased number of sperm (hypospermia), and sperm with decreased motility (asthenospermia) can all occur. Teratospermia has been noted at mean blood lead levels of 53  $\mu\text{g}/\text{dl}$  and hypospermia and asthenospermia at 41  $\mu\text{g}/\text{dl}$ . Furthermore, there appears to be a dose-response relationship for teratospermia in lead exposed workers.

Women exposed to lead may experience menstrual disturbances including dysmenorrhea, menorrhagia and amenorrhea. Following exposure to lead, women have a higher frequency of sterility, premature births, spontaneous miscarriages, and stillbirths.

Germ cells can be affected by lead and cause genetic damage in the egg or sperm cells before conception and result in failure to implant, miscarriage, stillbirth, or birth defects.

Infants of mothers with lead poisoning have a higher mortality during the first year and suffer from lowered birth weights, slower growth, and nervous system disorders.

Lead can pass through the placental barrier and lead levels in the mother's blood are comparable to concentrations of lead in the umbilical cord at birth. Transplacental passage becomes detectable at 12-14 weeks of gestation and increases until birth.

There is little direct data on damage to the fetus from exposure to lead but it is generally assumed that the fetus and newborn would be at least as susceptible to neurological damage as young children. Blood lead levels of 50-60  $\mu\text{g}/\text{dl}$  in children can cause significant neurobehavioral impairments and there is evidence of hyperactivity at blood levels as low as 25  $\mu\text{g}/\text{dl}$ . Given the overall body of literature concerning the adverse health effects of lead in children, OSHA feels that the blood lead level in children should be maintained below 30  $\mu\text{g}/\text{dl}$  with a population mean of 15  $\mu\text{g}/\text{dl}$ . Blood lead levels in the fetus and newborn likewise should not exceed 30  $\mu\text{g}/\text{dl}$ .

Because of lead's ability to pass through the placental barrier and also because of the demonstrated adverse effects of lead on reproductive function in both the male and female as well

as the risk of genetic damage of lead on both the ovum and sperm, OSHA recommends a 30 µg/dl maximum permissible blood lead level in both males and females who wish to bear children.

6. Other toxic effects. Debate and research continue on the effects of lead on the human body. Hypertension has frequently been noted in occupationally exposed individuals although it is difficult to assess whether this is due to lead's adverse effects on the kidney or if some other mechanism is involved. Vascular and electrocardiographic changes have been detected but have not been well characterized. Lead is thought to impair thyroid function and interfere with the pituitary-adrenal axis, but again these effects have not been well defined.

### *III. Medical Evaluation*

The most important principle in evaluating a worker for any occupational disease including lead poisoning is a high index of suspicion on the part of the examining physician. As discussed in Section 2, lead can affect numerous organ systems and produce a wide array of signs and symptoms, most of which are non-specific and subtle in nature at least in the early stages of disease. Unless serious concern for lead toxicity is present, many of the early clues to diagnosis may easily be overlooked.

The crucial initial step in the medical evaluation is recognizing that a worker's employment can result in exposure to lead. The worker will frequently be able to define exposures to lead and lead containing materials but often will not volunteer this information unless specifically asked. In other situations the worker may not know of any exposures to lead but the suspicion might be raised on the part of the physician because of the industry or occupation of the worker. Potential occupational exposure to lead and its compounds occur in many occupations in the construction industry, including demolition and salvaging operations, removal or encapsulation of materials containing lead, construction, alteration, repair or renovation of structures containing lead, transportation, disposal, storage or containment of lead or lead-containing materials on construction sites, and maintenance operations associated with construction activities.

Once the possibility for lead exposure is raised, the focus can then be directed toward eliciting information from the medical history, physical exam, and finally from laboratory data to evaluate the worker for potential lead toxicity.

A complete and detailed work history is important in the initial evaluation. A listing of all previous employment with information on job description, exposure to fumes or dust, known exposures to lead or other toxic substances, a description of any personal protective equipment used, and previous medical surveillance should all be included in the worker's record. Where exposure to lead is suspected, information concerning on-the-job personal hygiene, smoking or eating habits in work areas, laundry procedures, and use of any protective clothing or respiratory protection equipment should be noted. A complete work history is essential in the medical evaluation of a worker with suspected lead toxicity, especially when long term effects such as neurotoxicity and nephrotoxicity are considered.

The medical history is also of fundamental importance and should include a listing of all past and current medical conditions, current medications including proprietary drug intake, previous surgeries and hospitalizations, allergies, smoking history, alcohol consumption, and also non-

occupational lead exposures such as hobbies (hunting, riflery). Also known childhood exposures should be elicited. Any previous history of hematological, neurological, gastrointestinal, renal, psychological, gynecological, genetic, or reproductive problems should be specifically noted.

A careful and complete review of systems must be performed to assess both recognized complaints and subtle or slowly acquired symptoms which the worker might not appreciate as being significant. The review of symptoms should include the following:

1. General—weight loss, fatigue, decreased appetite.
2. Head, Eyes, Ears, Nose, Throat (HEENT)—headaches, visual disturbances or decreased visual acuity, hearing deficits or tinnitus, pigmentation of the oral mucosa, or metallic taste in mouth.
3. Cardio-pulmonary—shortness of breath, cough, chest pains, palpitations, or orthopnea.
4. Gastrointestinal—nausea, vomiting, heartburn, abdominal pain, constipation or diarrhea.
5. Neurologic—irritability, insomnia, weakness (fatigue), dizziness, loss of memory, confusion, hallucinations, incoordination, ataxia, decreased strength in hands or feet, disturbances in gait, difficulty in climbing stairs, or seizures.
6. Hematologic—pallor, easy fatigability, abnormal blood loss, melena.
7. Reproductive (male and female and spouse where relevant)—history of infertility, impotence, loss of libido, abnormal menstrual periods, history of miscarriages, stillbirths, or children with birth defects.
8. Musculo-skeletal—muscle and joint pains.

The physical examination should emphasize the neurological, gastrointestinal, and cardiovascular systems. The worker's weight and blood pressure should be recorded and the oral mucosa checked for pigmentation characteristic of a possible Burtonian or lead line on the gingiva. It should be noted, however, that the lead line may not be present even in severe lead poisoning if good oral hygiene is practiced.

The presence of pallor on skin examination may indicate an anemia which, if severe, might also be associated with a tachycardia. If an anemia is suspected, an active search for blood loss should be undertaken including potential blood loss through the gastrointestinal tract.

A complete neurological examination should include an adequate mental status evaluation including a search for behavioral and psychological disturbances, memory testing, evaluation for irritability, insomnia, hallucinations, and mental clouding. Gait and coordination should be examined along with close observation for tremor. A detailed evaluation of peripheral nerve function including careful sensory and motor function testing is warranted. Strength testing particularly of extensor muscle groups of all extremities is of fundamental importance.

Cranial nerve evaluation should also be included in the routine examination.

The abdominal examination should include auscultation for bowel sounds and abdominal bruits and palpation for organomegaly, masses, and diffuse abdominal tenderness.

Cardiovascular examination should evaluate possible early signs of congestive heart failure. Pulmonary status should be addressed particularly if respirator protection is contemplated.

As part of the medical evaluation, the interim lead standard requires the following laboratory studies:

1. Blood lead level
2. Hemoglobin and hematocrit determinations, red cell indices, and examination of the peripheral blood smear to evaluate red blood cell morphology
3. Blood urea nitrogen
4. Serum creatinine
5. Routine urinalysis with microscopic examination.
6. A zinc protoporphyrin level.

In addition to the above, the physician is authorized to order any further laboratory or other tests which he or she deems necessary in accordance with sound medical practice. The evaluation must also include pregnancy testing or laboratory evaluation of male fertility if requested by the employee. Additional tests which are probably not warranted on a routine basis but may be appropriate when blood lead and ZPP levels are equivocal include delta aminolevulinic acid and coproporphyrin concentrations in the urine, and dark-field illumination for detection of basophilic stippling in red blood cells.

If an anemia is detected further studies including a careful examination of the peripheral smear, reticulocyte count, stool for occult blood, serum iron, total iron binding capacity, bilirubin, and, if appropriate, vitamin B12 and folate may be of value in attempting to identify the cause of the anemia.

If a peripheral neuropathy is suspected, nerve conduction studies are warranted both for diagnosis and as a basis to monitor any therapy.

If renal disease is questioned, a 24 hour urine collection for creatinine clearance, protein, and electrolytes may be indicated. Elevated uric acid levels may result from lead-induced renal disease and a serum uric acid level might be performed.

An electrocardiogram and chest x-ray may be obtained as deemed appropriate.

Sophisticated and highly specialized testing should not be done routinely and where indicated should be under the direction of a specialist.

#### *IV. Laboratory Evaluation*

The blood lead level at present remains the single most important test to monitor lead exposure and is the test used in the medical surveillance program under the lead standard to guide employee medical removal. The ZPP has several advantages over the blood lead level. Because of its relatively recent development and the lack of extensive data concerning its interpretation, the ZPP currently remains an ancillary test.

This section will discuss the blood lead level and ZPP in detail and will outline their relative advantages and disadvantages. Other blood tests currently available to evaluate lead exposure will also be reviewed.

The blood lead level is a good index of current or recent lead absorption when there is no anemia present and when the worker has not taken any chelating agents. However, blood lead levels along with urinary lead levels do not necessarily indicate the total body burden of lead and are not adequate measures of past exposure. One reason for this is that lead has a high affinity for bone and up to 90% of the body's total lead is deposited there. A very important component of the total lead body burden is lead in soft tissue (liver, kidney, and brain). This fraction of the lead body burden, the biologically active lead, is not entirely reflected by blood lead levels since it is a function of the dynamics of lead absorption, distribution, deposition in bone and excretion. Following discontinuation of exposure to lead, the excess body burden is only slowly mobilized from bone and other relatively stable body stores and excreted. Consequently, a high blood lead level may only represent recent heavy exposure to lead without a significant total body excess and likewise a low blood lead level does not exclude an elevated total body burden of lead.

Also due to its correlation with recent exposures, the blood lead level may vary considerably over short time intervals.

To minimize laboratory error and erroneous results due to contamination, blood specimens must be carefully collected after thorough cleaning of the skin with appropriate methods using lead-free blood containers and analyzed by a reliable laboratory. Under the standard, samples must be analyzed in laboratories which are approved by OSHA. Analysis is to be made using atomic absorption spectrophotometry, anodic stripping voltammetry or any method which meets the accuracy requirements set forth by the standard.

The determination of lead in urine is generally considered a less reliable monitoring technique than analysis of whole blood primarily due to individual variability in urinary excretion capacity as well as the technical difficulty of obtaining accurate 24 hour urine collections. In addition, workers with renal insufficiency, whether due to lead or some other cause, may have decreased lead clearance and consequently urine lead levels may underestimate the true lead burden. Therefore, urine lead levels should not be used as a routine test.

The zinc protoporphyrin test, unlike the blood lead determination, measures an adverse metabolic effect of lead and as such is a better indicator of lead toxicity than the level of blood lead itself. The level of ZPP reflects lead absorption over the preceding 3 to 4 months, and therefore is a better indicator of lead body burden. The ZPP requires more time than the blood lead to read significantly elevated levels; the return to normal after discontinuing lead exposure is also slower.

Furthermore, the ZPP test is simpler, faster, and less expensive to perform and no contamination is possible. Many investigators believe it is the most reliable means of monitoring chronic lead absorption.

Zinc protoporphyrin results from the inhibition of the enzyme ferrochelatase which catalyzes the insertion of an iron molecule into the protoporphyrin molecule, which then becomes heme. If iron is not inserted into the molecule then zinc, having a greater affinity for protoporphyrin, takes the place of the iron, forming ZPP.

An elevation in the level of circulating ZPP may occur at blood lead levels as low as 20-30  $\mu\text{g}/\text{dl}$  in some workers. Once the blood lead level has reached 40  $\mu\text{g}/\text{dl}$  there is more marked rise in the ZPP value from its normal range of less than 100  $\mu\text{g}/\text{dl}$  100 ml. Increases in blood lead levels beyond 40  $\mu\text{g}/100$  g are associated with exponential increases in ZPP.

Whereas blood lead levels fluctuate over short time spans, ZPP levels remain relatively stable. ZPP is measured directly in red blood cells and is present for the cell's entire 120 day life-span. Therefore, the ZPP level in blood reflects the average ZPP production over the previous 3-4 months and consequently the average lead exposure during that time interval.

It is recommended that a hematocrit be determined whenever a confirmed ZPP of 50  $\mu\text{g}/100$  ml whole blood is obtained to rule out a significant underlying anemia. If the ZPP is in excess of 100  $\mu\text{g}/100$  ml and not associated with abnormal elevations in blood lead levels, the laboratory should be checked to be sure that blood leads were determined using atomic absorption spectrophotometry anodic stripping voltammetry, or any method which meets the accuracy requirements set forth by the standard by an OSHA approved laboratory which is experienced in lead level determinations. Repeat periodic blood lead studies should be obtained in all individuals with elevated ZPP levels to be certain that an associated elevated blood lead level has not been missed due to transient fluctuations in blood leads.

ZPP has a characteristic fluorescence spectrum with a peak at 594 nm which is detectable with a hematofluorimeter. The hematofluorimeter is accurate and portable and can provide on-site, instantaneous results for workers who can be frequently tested via a finger prick.

However, careful attention must be given to calibration and quality control procedures. Limited data on blood lead-ZPP correlations and the ZPP levels which are associated with the adverse health effects discussed in Section 2 are the major limitations of the test. Also it is difficult to correlate ZPP levels with environmental exposure and there is some variation of response with age and sex. Nevertheless, the ZPP promises to be an important diagnostic test for the early detection of lead toxicity and its value will increase as more data is collected regarding its relationship to other manifestations of lead poisoning.

Levels of delta-aminolevulinic acid (ALA) in the urine are also used as a measure of lead exposure. Increasing concentrations of ALA are believed to result from the inhibition of the enzyme delta-aminolevulinic acid dehydrase (ALA-D). Although the test is relatively easy to perform, inexpensive, and rapid, the disadvantages include variability in results, the necessity to collect a complete 24 hour urine sample which has a specific gravity greater than 1.010, and also the fact that ALA decomposes in the presence of light.

The pattern of porphyrin excretion in the urine can also be helpful in identifying lead intoxication. With lead poisoning, the urine concentrations of coproporphyrins I and II, porphobilinogen and uroporphyrin I rise. The most important increase, however, is that of coproporphyrin III; levels may exceed 5,000 µg/l in the urine in lead poisoned individuals, but its correlation with blood lead levels and ZPP are not as good as those of ALA. Increases in urinary porphyrins are not diagnostic of lead toxicity and may be seen in porphyria, some liver diseases, and in patients with high reticulocyte counts.

Summary. The Occupational Safety and Health Administration's interim standard for inorganic lead in the construction industry places significant emphasis on the medical surveillance of all workers exposed to levels of inorganic lead above 30 µg/m<sup>3</sup> TWA. The physician has a fundamental role in this surveillance program, and in the operation of the medical removal protection program.

Even with adequate worker education on the adverse health effects of lead and appropriate training in work practices, personal hygiene and other control measures, the physician has a primary responsibility for evaluating potential lead toxicity in the worker. It is only through a careful and detailed medical and work history, a complete physical examination and appropriate laboratory testing that an accurate assessment can be made. Many of the adverse health effects of lead toxicity are either irreversible or only partially reversible and therefore early detection of disease is very important.

This document outlines the medical monitoring program as defined by the occupational safety and health standard for inorganic lead. It reviews the adverse health effects of lead poisoning and describes the important elements of the history and physical examinations as they relate to these adverse effects. Finally, the appropriate laboratory testing for evaluating lead exposure and toxicity is presented.

It is hoped that this review and discussion will give the physician a better understanding of the OSHA standard with the ultimate goal of protecting the health and well-being of the worker exposed to lead under his or her care.

[58 FR 26627, May 4, 1993, as amended at 58 FR 34218, June 24, 1993; 61 FR 5510, Feb. 13, 1996; 63 FR 1296, Jan. 8, 1998; 70 FR 1143, Jan. 5, 2005; 71 FR 16674, Apr. 3, 2006; 71 FR 50191, Aug. 24, 2006; 73 FR 75588, Dec. 12, 2008; 76 FR 33611, June 8, 2011; 76 FR 80741, Dec. 27, 2011; 77 FR 17890, Mar. 26, 2012; 85 FR 8735, Feb. 18, 2020]

<https://www.ecfr.gov/cgi-bin/text-idx?SID=9fe6f31e684a2a982236fdbfd7b07342&mc=true&node=pt29.8.1926&rgn=div5#se29.8.1926>  
162

# Occupational Safety and Health Administration

By Standard Number / 910.134 - Respiratory Protection.

---

- **Part Number:** 1910
  - **Part Number Title:** Occupational Safety and Health Standards
  - **Subpart:** 1910 Subpart I
  - **Subpart Title:** Personal Protective Equipment
  - **Standard Number:** [1910.134](#)
  - **Title:** Respiratory Protection.
  - **Appendix:** [A](#); [B-1](#); [B-2](#); [C](#); [D](#)
  - **GPO Source:** [e-CFR](#)
- 

## [1910.134\(a\)](#)

### ***Permissible practice.***

#### [1910.134\(a\)\(1\)](#)

In the control of those occupational diseases caused by breathing air contaminated with harmful dusts, fogs, fumes, mists, gases, smokes, sprays, or vapors, the primary objective shall be to prevent atmospheric contamination. This shall be accomplished as far as feasible by accepted engineering control measures (for example, enclosure or confinement of the operation, general and local ventilation, and substitution of less toxic materials). When effective engineering controls are not feasible, or while they are being instituted, appropriate respirators shall be used pursuant to this section.

#### [1910.134\(a\)\(2\)](#)

A respirator shall be provided to each employee when such equipment is necessary to protect the health of such employee. The employer shall provide the respirators which are applicable and suitable for the purpose intended. The employer shall be responsible for the establishment and maintenance of a respiratory protection program, which shall include the requirements outlined in paragraph (c) of this section. The program shall cover each employee required by this section to use a respirator.

#### [1910.134\(b\)](#)

**Definitions.** The following definitions are important terms used in the respiratory protection standard in this section.

***Air-purifying respirator*** means a respirator with an air-purifying filter, cartridge, or canister that removes specific air contaminants by passing ambient air through the air-purifying element.

***Assigned protection factor (APF)*** means the workplace level of respiratory protection that a respirator or class of respirators is expected to provide to employees when the employer implements a continuing, effective respiratory protection program as specified by this section.

**Atmosphere-supplying respirator** means a respirator that supplies the respirator user with breathing air from a source independent of the ambient atmosphere, and includes supplied-air respirators (SARs) and self-contained breathing apparatus (SCBA) units.

**Canister or cartridge** means a container with a filter, sorbent, or catalyst, or combination of these items, which removes specific contaminants from the air passed through the container.

**Demand respirator** means an atmosphere-supplying respirator that admits breathing air to the facepiece only when a negative pressure is created inside the facepiece by inhalation.

**Emergency situation** means any occurrence such as, but not limited to, equipment failure, rupture of containers, or failure of control equipment that may or does result in an uncontrolled significant release of an airborne contaminant.

**Employee exposure** means exposure to a concentration of an airborne contaminant that would occur if the employee were not using respiratory protection.

**End-of-service-life indicator (ESLI)** means a system that warns the respirator user of the approach of the end of adequate respiratory protection, for example, that the sorbent is approaching saturation or is no longer effective.

**Escape-only respirator** means a respirator intended to be used only for emergency exit.

**Filter or air purifying element** means a component used in respirators to remove solid or liquid aerosols from the inspired air.

**Filtering facepiece (dust mask)** means a negative pressure particulate respirator with a filter as an integral part of the facepiece or with the entire facepiece composed of the filtering medium.

**Fit factor** means a quantitative estimate of the fit of a particular respirator to a specific individual, and typically estimates the ratio of the concentration of a substance in ambient air to its concentration inside the respirator when worn.

**Fit test** means the use of a protocol to qualitatively or quantitatively evaluate the fit of a respirator on an individual. (See also Qualitative fit test QLFT and Quantitative fit test QNFT.)

**Helmet** means a rigid respiratory inlet covering that also provides head protection against impact and penetration.

**High efficiency particulate air (HEPA) filter** means a filter that is at least 99.97% efficient in removing monodisperse particles of 0.3 micrometers in diameter. The equivalent NIOSH 42 CFR 84 particulate filters are the N100, R100, and P100 filters.

**Hood** means a respiratory inlet covering that completely covers the head and neck and may also cover portions of the shoulders and torso.

**Immediately dangerous to life or health (IDLH)** means an atmosphere that poses an immediate threat to life, would cause irreversible adverse health effects, or would impair an individual's ability to escape from a dangerous atmosphere.

**Interior structural firefighting** means the physical activity of fire suppression, rescue or both, inside of buildings or enclosed structures which are involved in a fire situation beyond the incipient stage. (See 29 CFR 1910.155)

**Loose-fitting facepiece** means a respiratory inlet covering that is designed to form a partial seal with the face.

**Maximum use concentration (MUC)** means the maximum atmospheric concentration of a hazardous substance from which an employee can be expected to be protected when wearing a respirator, and is determined by the assigned protection factor of the respirator or class of respirators and the exposure limit of the hazardous substance. The MUC can be determined mathematically by multiplying the assigned protection factor specified for a respirator by the required OSHA permissible exposure limit, short-term exposure limit, or ceiling limit. When no OSHA exposure limit is available for a hazardous substance, an employer must determine an MUC on the basis of relevant available information and informed professional judgment.

**Negative pressure respirator (tight fitting)** means a respirator in which the air pressure inside the facepiece is negative during inhalation with respect to the ambient air pressure outside the respirator.

**Oxygen deficient atmosphere** means an atmosphere with an oxygen content below 19.5% by volume.

**Physician or other licensed health care professional (PLHCP)** means an individual whose legally permitted scope of practice (i.e., license, registration, or certification) allows him or her to independently provide, or be delegated the responsibility to provide, some or all of the health care services required by paragraph (e) of this section.

**Positive pressure respirator** means a respirator in which the pressure inside the respiratory inlet covering exceeds the ambient air pressure outside the respirator.

**Powered air-purifying respirator (PAPR)** means an air-purifying respirator that uses a blower to force the ambient air through air-purifying elements to the inlet covering.

**Pressure demand respirator** means a positive pressure atmosphere-supplying respirator that admits breathing air to the facepiece when the positive pressure is reduced inside the facepiece by inhalation.

**Qualitative fit test (QLFT)** means a pass/fail fit test to assess the adequacy of respirator fit that relies on the individual's response to the test agent.

**Quantitative fit test (QNFT)** means an assessment of the adequacy of respirator fit by numerically measuring the amount of leakage into the respirator.

**Respiratory inlet covering** means that portion of a respirator that forms the protective barrier between the user's respiratory tract and an air-purifying device or breathing air source, or both. It may be a facepiece, helmet, hood, suit, or a mouthpiece respirator with nose clamp.

**Self-contained breathing apparatus (SCBA)** means an atmosphere-supplying respirator for which the breathing air source is designed to be carried by the user.

**Service life** means the period of time that a respirator, filter or sorbent, or other respiratory equipment provides adequate protection to the wearer.

**Supplied-air respirator (SAR) or airline respirator** means an atmosphere-supplying respirator for which the source of breathing air is not designed to be carried by the user.

**This section** means this respiratory protection standard.

**Tight-fitting facepiece** means a respiratory inlet covering that forms a complete seal with the face.

**User seal check** means an action conducted by the respirator user to determine if the respirator is properly seated to the face.

[1910.134\(c\)](#)

**Respiratory protection program.** This paragraph requires the employer to develop and implement a written respiratory protection program with required worksite-specific procedures and elements for required respirator use. The program must be administered by a suitably trained program administrator. In addition, certain program elements may be required for voluntary use to prevent potential hazards associated with the use of the respirator. The Small Entity Compliance Guide contains criteria for the selection of a program administrator and a sample program that meets the requirements of this paragraph. Copies of the Small Entity Compliance Guide will be available on or about April 8, 1998 from the Occupational Safety and Health Administration's Office of Publications, Room N 3101, 200 Constitution Avenue, NW, Washington, DC, 20210 (202-219-4667).

[1910.134\(c\)\(1\)](#)

In any workplace where respirators are necessary to protect the health of the employee or whenever respirators are required by the employer, the employer shall establish and implement a written respiratory protection program with worksite-specific procedures. The program shall be updated as necessary to reflect those changes in workplace conditions that affect respirator use. The employer shall include in the program the following provisions of this section, as applicable:

[1910.134\(c\)\(1\)\(i\)](#)

Procedures for selecting respirators for use in the workplace;

[1910.134\(c\)\(1\)\(ii\)](#)

Medical evaluations of employees required to use respirators;

[1910.134\(c\)\(1\)\(iii\)](#)

Fit testing procedures for tight-fitting respirators;

[1910.134\(c\)\(1\)\(iv\)](#)

Procedures for proper use of respirators in routine and reasonably foreseeable emergency situations;

[1910.134\(c\)\(1\)\(v\)](#)

Procedures and schedules for cleaning, disinfecting, storing, inspecting, repairing, discarding, and otherwise maintaining respirators;

[1910.134\(c\)\(1\)\(vi\)](#)

Procedures to ensure adequate air quality, quantity, and flow of breathing air for atmosphere-supplying respirators;

[1910.134\(c\)\(1\)\(vii\)](#)

Training of employees in the respiratory hazards to which they are potentially exposed during routine and emergency situations;

[1910.134\(c\)\(1\)\(viii\)](#)

Training of employees in the proper use of respirators, including putting on and removing them, any limitations on their use, and their maintenance; and

[1910.134\(c\)\(1\)\(ix\)](#)

Procedures for regularly evaluating the effectiveness of the program.

[1910.134\(c\)\(2\)](#)

Where respirator use is not required:

[1910.134\(c\)\(2\)\(i\)](#)

An employer may provide respirators at the request of employees or permit employees to use their own respirators, if the employer determines that such respirator use will not in itself create a hazard. If the employer determines that any voluntary respirator use is permissible, the employer shall provide the respirator users with the information contained in Appendix D to this section ("Information for Employees Using Respirators When Not Required Under the Standard"); and

[1910.134\(c\)\(2\)\(ii\)](#)

In addition, the employer must establish and implement those elements of a written respiratory protection program necessary to ensure that any employee using a respirator voluntarily is medically able to use that respirator, and that the respirator is cleaned, stored, and maintained so that its use does not present a health hazard to the user. Exception: Employers are not required to include in a written respiratory protection program those employees whose only use of respirators involves the voluntary use of filtering facepieces (dust masks).

[1910.134\(c\)\(3\)](#)

The employer shall designate a program administrator who is qualified by appropriate training or experience that is commensurate with the complexity of the program to administer or oversee the respiratory protection program and conduct the required evaluations of program effectiveness.

[1910.134\(c\)\(4\)](#)

The employer shall provide respirators, training, and medical evaluations at no cost to the employee.

1910.134(d)

**Selection of respirators.** This paragraph requires the employer to evaluate respiratory hazard(s) in the workplace, identify relevant workplace and user factors, and base respirator selection on these factors. The paragraph also specifies appropriately protective respirators for use in IDLH atmospheres, and limits the selection and use of air-purifying respirators.

1910.134(d)(1)

**General requirements.**

1910.134(d)(1)(i)

The employer shall select and provide an appropriate respirator based on the respiratory hazard(s) to which the worker is exposed and workplace and user factors that affect respirator performance and reliability.

1910.134(d)(1)(ii)

The employer shall select a NIOSH-certified respirator. The respirator shall be used in compliance with the conditions of its certification.

1910.134(d)(1)(iii)

The employer shall identify and evaluate the respiratory hazard(s) in the workplace; this evaluation shall include a reasonable estimate of employee exposures to respiratory hazard(s) and an identification of the contaminant's chemical state and physical form. Where the employer cannot identify or reasonably estimate the employee exposure, the employer shall consider the atmosphere to be IDLH.

1910.134(d)(1)(iv)

The employer shall select respirators from a sufficient number of respirator models and sizes so that the respirator is acceptable to, and correctly fits, the user.

1910.134(d)(2)

**Respirators for IDLH atmospheres.**

1910.134(d)(2)(i)

The employer shall provide the following respirators for employee use in IDLH atmospheres:

1910.134(d)(2)(i)(A)

A full facepiece pressure demand SCBA certified by NIOSH for a minimum service life of thirty minutes, or

1910.134(d)(2)(i)(B)

A combination full facepiece pressure demand supplied-air respirator (SAR) with auxiliary self-contained air supply.

1910.134(d)(2)(ii)

Respirators provided only for escape from IDLH atmospheres shall be NIOSH-certified for escape from the atmosphere in which they will be used.

1910.134(d)(2)(iii)

All oxygen-deficient atmospheres shall be considered IDLH. Exception: If the employer demonstrates that, under all foreseeable conditions, the oxygen concentration can be maintained within the ranges specified in Table II of this section (i.e., for the altitudes set out in the table), then any atmosphere-supplying respirator may be used.

1910.134(d)(3)

**Respirators for atmospheres that are not IDLH.**

1910.134(d)(3)(i)

The employer shall provide a respirator that is adequate to protect the health of the employee and ensure compliance with all other OSHA statutory and regulatory requirements, under routine and reasonably foreseeable emergency situations.

1910.134(d)(3)(i)(A)

**Assigned Protection Factors (APFs)** Employers must use the assigned protection factors listed in Table 1 to select a respirator that meets or exceeds the required level of employee protection. When using a combination respirator (e.g., airline respirators with an air-purifying filter), employers must ensure that the assigned protection factor is appropriate to the mode of operation in which the respirator is being used.

Table 1. -- Assigned Protection Factors<sup>5</sup>

Type of respirator <sup>1, 2</sup>	Quarter mask	Half mask	Full facepiecehood	Helmet/ Loose-fitting facepiece
1. Air-Purifying Respirator	5	<sup>3</sup> 10	50	.....
2. Powered Air-Purifying Respirator (PAPR).....		50	1,000	<sup>4</sup> 25/1,00025
3. Supplied-Air Respirator (SAR) or Airline Respirator				
• Demand mode	.....	10	50	.....
• Continuous flow mode	.....	50	1,000	<sup>4</sup> 25/1,00025
• Pressure-demand or other positive-pressure mode	.....	50	1,000	.....
4. Self-Contained Breathing Apparatus (SCBA)				
• Demand mode	.....	10	50	50
• Pressure-demand or other positive-pressure mode (e.g., open/closed circuit)	.....	.....	10,000	10,000

**Notes:**

<sup>1</sup>Employers may select respirators assigned for use in higher workplace concentrations of a hazardous substance for use at lower concentrations of that substance, or when required respirator use is independent of concentration.

<sup>2</sup>The assigned protection factors in Table 1 are only effective when the employer implements a continuing, effective respirator program as required by this section (29 CFR 1910.134), including training, fit testing, maintenance, and use requirements.

<sup>3</sup>This APF category includes filtering facepieces, and half masks with elastomeric facepieces. <sup>4</sup>The employer must have evidence provided by the respirator manufacturer that testing of these respirators demonstrates performance at a level of protection of 1,000 or greater to receive an APF of 1,000. This level of performance can best be demonstrated by performing a WPF or SWPF study or equivalent testing. Absent such testing, all other PAPRs and SARs with helmets/hoods are to be treated as loose-fitting facepiece respirators, and receive an APF of 25.

<sup>5</sup>These APFs do not apply to respirators used solely for escape. For escape respirators used in association with specific substances covered by 29 CFR 1910 subpart Z, employers must refer to the appropriate substance-specific standards in that subpart. Escape respirators for other IDLH atmospheres are specified by 29 CFR 1910.134 (d)(2)(ii).

1910.134(d)(3)(i)(B)

### **Maximum Use Concentration (MUC)**

#### [1910.134\(d\)\(3\)\(i\)\(B\)\(1\)](#)

The employer must select a respirator for employee use that maintains the employee's exposure to the hazardous substance, when measured outside the respirator, at or below the MUC.

#### [1910.134\(d\)\(3\)\(i\)\(B\)\(2\)](#)

Employers must not apply MUCs to conditions that are immediately dangerous to life or health (IDLH); instead, they must use respirators listed for IDLH conditions in paragraph (d)(2) of this standard.

#### [1910.134\(d\)\(3\)\(i\)\(B\)\(3\)](#)

When the calculated MUC exceeds the IDLH level for a hazardous substance, or the performance limits of the cartridge or canister, then employers must set the maximum MUC at that lower limit.

#### [1910.134\(d\)\(3\)\(ii\)](#)

The respirator selected shall be appropriate for the chemical state and physical form of the contaminant.

#### [1910.134\(d\)\(3\)\(iii\)](#)

For protection against gases and vapors, the employer shall provide:

##### [1910.134\(d\)\(3\)\(iii\)\(A\)](#)

An atmosphere-supplying respirator, or

##### [1910.134\(d\)\(3\)\(iii\)\(B\)](#)

An air-purifying respirator, provided that:

##### [1910.134\(d\)\(3\)\(iii\)\(B\)\(1\)](#)

The respirator is equipped with an end-of-service-life indicator (ESLI) certified by NIOSH for the contaminant; or

##### [1910.134\(d\)\(3\)\(iii\)\(B\)\(2\)](#)

If there is no ESLI appropriate for conditions in the employer's workplace, the employer implements a change schedule for canisters and cartridges that is based on objective information or data that will ensure that canisters and cartridges are changed before the end of their service life. The employer shall describe in the respirator program the information and data relied upon and the basis for the canister and cartridge change schedule and the basis for reliance on the data.

#### [1910.134\(d\)\(3\)\(iv\)](#)

For protection against particulates, the employer shall provide:

##### [1910.134\(d\)\(3\)\(iv\)\(A\)](#)

An atmosphere-supplying respirator; or

##### [1910.134\(d\)\(3\)\(iv\)\(B\)](#)

An air-purifying respirator equipped with a filter certified by NIOSH under 30 CFR part 11 as a high efficiency particulate air (HEPA) filter, or an air-purifying respirator equipped with a filter certified for particulates by NIOSH under 42 CFR part 84; or

##### [1910.134\(d\)\(3\)\(iv\)\(C\)](#)

For contaminants consisting primarily of particles with mass median aerodynamic diameters (MMAD) of at least 2 micrometers, an air-purifying respirator equipped with any filter certified for particulates by NIOSH.

TABLE I. -- ASSIGNED PROTECTION FACTORS  
 [RESERVED]  
 TABLE II

Altitude (ft.)	Oxygen deficient Atmospheres (% O <sub>2</sub> ) for which the employer atmosphere may rely on supplying respirators
Less than 3,001	16.0-19.5
3,001-4,000	16.4-19.5
4,001-5,000	17.1-19.5
5,001-6,000	17.8-19.5
6,001-7,000	18.5-19.5
7,001-8,000 <sup>1</sup>	19.3-19.5.

<sup>1</sup>Above 8,000 feet the exception does not apply. Oxygen-enriched breathing air must be supplied above 14,000 feet.

1910.134(e)

**Medical evaluation.** Using a respirator may place a physiological burden on employees that varies with the type of respirator worn, the job and workplace conditions in which the respirator is used, and the medical status of the employee. Accordingly, this paragraph specifies the minimum requirements for medical evaluation that employers must implement to determine the employee's ability to use a respirator.

1910.134(e)(1)

**General.** The employer shall provide a medical evaluation to determine the employee's ability to use a respirator, before the employee is fit tested or required to use the respirator in the workplace. The employer may discontinue an employee's medical evaluations when the employee is no longer required to use a respirator.

1910.134(e)(2)

**Medical evaluation procedures.**

1910.134(e)(2)(i)

The employer shall identify a physician or other licensed health care professional (PLHCP) to perform medical evaluations using a medical questionnaire or an initial medical examination that obtains the same information as the medical questionnaire.

1910.134(e)(2)(ii)

The medical evaluation shall obtain the information requested by the questionnaire in Sections 1 and 2, Part A of Appendix C of this section.

1910.134(e)(3)

**Follow-up medical examination.**

1910.134(e)(3)(i)

The employer shall ensure that a follow-up medical examination is provided for an employee who gives a positive response to any question among questions 1 through 8 in Section 2, Part A of Appendix C or whose initial medical examination demonstrates the need for a follow-up medical examination.

[1910.134\(e\)\(3\)\(ii\)](#)

The follow-up medical examination shall include any medical tests, consultations, or diagnostic procedures that the PLHCP deems necessary to make a final determination.

[1910.134\(e\)\(4\)](#)

***Administration of the medical questionnaire and examinations.***

[1910.134\(e\)\(4\)\(i\)](#)

The medical questionnaire and examinations shall be administered confidentially during the employee's normal working hours or at a time and place convenient to the employee. The medical questionnaire shall be administered in a manner that ensures that the employee understands its content.

[1910.134\(e\)\(4\)\(ii\)](#)

The employer shall provide the employee with an opportunity to discuss the questionnaire and examination results with the PLHCP.

[1910.134\(e\)\(5\)](#)

***Supplemental information for the PLHCP.***

[1910.134\(e\)\(5\)\(i\)](#)

The following information must be provided to the PLHCP before the PLHCP makes a recommendation concerning an employee's ability to use a respirator:

[1910.134\(e\)\(5\)\(i\)\(A\)](#)

(A) The type and weight of the respirator to be used by the employee;

[1910.134\(e\)\(5\)\(i\)\(B\)](#)

The duration and frequency of respirator use (including use for rescue and escape);

[1910.134\(e\)\(5\)\(i\)\(C\)](#)

The expected physical work effort;

[1910.134\(e\)\(5\)\(i\)\(D\)](#)

Additional protective clothing and equipment to be worn; and

[1910.134\(e\)\(5\)\(i\)\(E\)](#)

Temperature and humidity extremes that may be encountered.

[1910.134\(e\)\(5\)\(ii\)](#)

Any supplemental information provided previously to the PLHCP regarding an employee need not be provided for a subsequent medical evaluation if the information and the PLHCP remain the same.

[1910.134\(e\)\(5\)\(iii\)](#)

The employer shall provide the PLHCP with a copy of the written respiratory protection program and a copy of this section.

**Note to Paragraph (e)(5)(iii):** When the employer replaces a PLHCP, the employer must ensure that the new PLHCP obtains this information, either by providing the documents directly to the PLHCP or having the documents transferred from the former PLHCP to the new PLHCP.

However, OSHA does not expect employers to have employees medically reevaluated solely because a new PLHCP has been selected.

1910.134(e)(6)

**Medical determination.** In determining the employee's ability to use a respirator, the employer shall:

1910.134(e)(6)(i)

Obtain a written recommendation regarding the employee's ability to use the respirator from the PLHCP. The recommendation shall provide only the following information:

1910.134(e)(6)(i)(A)

Any limitations on respirator use related to the medical condition of the employee, or relating to the workplace conditions in which the respirator will be used, including whether or not the employee is medically able to use the respirator;

1910.134(e)(6)(i)(B)

The need, if any, for follow-up medical evaluations; and

1910.134(e)(6)(i)(C)

A statement that the PLHCP has provided the employee with a copy of the PLHCP's written recommendation.

1910.134(e)(6)(ii)

If the respirator is a negative pressure respirator and the PLHCP finds a medical condition that may place the employee's health at increased risk if the respirator is used, the employer shall provide a PAPR if the PLHCP's medical evaluation finds that the employee can use such a respirator; if a subsequent medical evaluation finds that the employee is medically able to use a negative pressure respirator, then the employer is no longer required to provide a PAPR.

1910.134(e)(7)

**Additional medical evaluations.** At a minimum, the employer shall provide additional medical evaluations that comply with the requirements of this section if:

1910.134(e)(7)(i)

An employee reports medical signs or symptoms that are related to ability to use a respirator;

1910.134(e)(7)(ii)

A PLHCP, supervisor, or the respirator program administrator informs the employer that an employee needs to be reevaluated;

1910.134(e)(7)(iii)

Information from the respiratory protection program, including observations made during fit testing and program evaluation, indicates a need for employee reevaluation; or

1910.134(e)(7)(iv)

A change occurs in workplace conditions (e.g., physical work effort, protective clothing, temperature) that may result in a substantial increase in the physiological burden placed on an employee.

1910.134(f)

**Fit testing.** This paragraph requires that, before an employee may be required to use any respirator with a negative or positive pressure tight-fitting facepiece, the employee must be fit tested with the same make, model, style, and size of respirator that will be used. This paragraph specifies the kinds of fit tests allowed, the procedures for conducting them, and how the results of the fit tests must be used.

1910.134(f)(1)

The employer shall ensure that employees using a tight-fitting facepiece respirator pass an appropriate qualitative fit test (QLFT) or quantitative fit test (QNFT) as stated in this paragraph.

#### 1910.134(f)(2)

The employer shall ensure that an employee using a tight-fitting facepiece respirator is fit tested prior to initial use of the respirator, whenever a different respirator facepiece (size, style, model or make) is used, and at least annually thereafter.

#### 1910.134(f)(3)

The employer shall conduct an additional fit test whenever the employee reports, or the employer, PLHCP, supervisor, or program administrator makes visual observations of, changes in the employee's physical condition that could affect respirator fit. Such conditions include, but are not limited to, facial scarring, dental changes, cosmetic surgery, or an obvious change in body weight.

#### 1910.134(f)(4)

If after passing a QLFT or QNFT, the employee subsequently notifies the employer, program administrator, supervisor, or PLHCP that the fit of the respirator is unacceptable, the employee shall be given a reasonable opportunity to select a different respirator facepiece and to be retested.

#### 1910.134(f)(5)

The fit test shall be administered using an OSHA-accepted QLFT or QNFT protocol. The OSHA-accepted QLFT and QNFT protocols and procedures are contained in Appendix A of this section.

#### 1910.134(f)(6)

QLFT may only be used to fit test negative pressure air-purifying respirators that must achieve a fit factor of 100 or less.

#### 1910.134(f)(7)

If the fit factor, as determined through an OSHA-accepted QNFT protocol, is equal to or greater than 100 for tight-fitting half facepieces, or equal to or greater than 500 for tight-fitting full facepieces, the QNFT has been passed with that respirator.

#### 1910.134(f)(8)

Fit testing of tight-fitting atmosphere-supplying respirators and tight-fitting powered air-purifying respirators shall be accomplished by performing quantitative or qualitative fit testing in the negative pressure mode, regardless of the mode of operation (negative or positive pressure) that is used for respiratory protection.

#### 1910.134(f)(8)(i)

Qualitative fit testing of these respirators shall be accomplished by temporarily converting the respirator user's actual facepiece into a negative pressure respirator with appropriate filters, or by using an identical negative pressure air-purifying respirator facepiece with the same sealing surfaces as a surrogate for the atmosphere-supplying or powered air-purifying respirator facepiece.

#### 1910.134(f)(8)(ii)

Quantitative fit testing of these respirators shall be accomplished by modifying the facepiece to allow sampling inside the facepiece in the breathing zone of the user, midway between the nose and mouth. This requirement shall be accomplished by installing a permanent sampling probe onto a surrogate facepiece, or by using a sampling adapter designed to temporarily provide a means of sampling air from inside the facepiece.

#### 1910.134(f)(8)(iii)

Any modifications to the respirator facepiece for fit testing shall be completely removed, and the facepiece restored to NIOSH-approved configuration, before that facepiece can be used in the workplace.

#### 1910.134(g)

**Use of respirators.** This paragraph requires employers to establish and implement procedures for the proper use of respirators. These requirements include prohibiting conditions that may result in facepiece seal leakage, preventing employees from removing respirators in hazardous environments, taking actions to ensure continued effective respirator operation throughout the work shift, and establishing procedures for the use of respirators in IDLH atmospheres or in interior structural firefighting situations.

#### 1910.134(g)(1)

##### **Facepiece seal protection.**

#### 1910.134(g)(1)(i)

The employer shall not permit respirators with tight-fitting facepieces to be worn by employees who have:

#### 1910.134(g)(1)(i)(A)

Facial hair that comes between the sealing surface of the facepiece and the face or that interferes with valve function; or

#### 1910.134(g)(1)(i)(B)

Any condition that interferes with the face-to-facepiece seal or valve function.

#### 1910.134(g)(1)(ii)

If an employee wears corrective glasses or goggles or other personal protective equipment, the employer shall ensure that such equipment is worn in a manner that does not interfere with the seal of the facepiece to the face of the user.

#### 1910.134(g)(1)(iii)

For all tight-fitting respirators, the employer shall ensure that employees perform a user seal check each time they put on the respirator using the procedures in Appendix B-1 or procedures recommended by the respirator manufacturer that the employer demonstrates are as effective as those in Appendix B-1 of this section.

#### 1910.134(g)(2)

##### **Continuing respirator effectiveness.**

#### 1910.134(g)(2)(i)

Appropriate surveillance shall be maintained of work area conditions and degree of employee exposure or stress. When there is a change in work area conditions or degree of employee exposure or stress that may affect respirator effectiveness, the employer shall reevaluate the continued effectiveness of the respirator.

#### 1910.134(g)(2)(ii)

The employer shall ensure that employees leave the respirator use area:

#### 1910.134(g)(2)(ii)(A)

To wash their faces and respirator facepieces as necessary to prevent eye or skin irritation associated with respirator use; or

#### 1910.134(g)(2)(ii)(B)

If they detect vapor or gas breakthrough, changes in breathing resistance, or leakage of the facepiece; or

#### 1910.134(g)(2)(ii)(C)

To replace the respirator or the filter, cartridge, or canister elements.

1910.134(g)(2)(iii)

If the employee detects vapor or gas breakthrough, changes in breathing resistance, or leakage of the facepiece, the employer must replace or repair the respirator before allowing the employee to return to the work area.

1910.134(g)(3)

**Procedures for IDLH atmospheres.** For all IDLH atmospheres, the employer shall ensure that:

1910.134(g)(3)(i)

One employee or, when needed, more than one employee is located outside the IDLH atmosphere;

1910.134(g)(3)(ii)

Visual, voice, or signal line communication is maintained between the employee(s) in the IDLH atmosphere and the employee(s) located outside the IDLH atmosphere;

1910.134(g)(3)(iii)

The employee(s) located outside the IDLH atmosphere are trained and equipped to provide effective emergency rescue;

1910.134(g)(3)(iv)

The employer or designee is notified before the employee(s) located outside the IDLH atmosphere enter the IDLH atmosphere to provide emergency rescue;

1910.134(g)(3)(v)

The employer or designee authorized to do so by the employer, once notified, provides necessary assistance appropriate to the situation;

1910.134(g)(3)(vi)

Employee(s) located outside the IDLH atmospheres are equipped with:

1910.134(g)(3)(vi)(A)

Pressure demand or other positive pressure SCBAs, or a pressure demand or other positive pressure supplied-air respirator with auxiliary SCBA; and either

1910.134(g)(3)(vi)(B)

Appropriate retrieval equipment for removing the employee(s) who enter(s) these hazardous atmospheres where retrieval equipment would contribute to the rescue of the employee(s) and would not increase the overall risk resulting from entry; or

1910.134(g)(3)(vi)(C)

Equivalent means for rescue where retrieval equipment is not required under paragraph (g)(3)(vi)(B).

1910.134(g)(4)

**Procedures for interior structural firefighting.** In addition to the requirements set forth under paragraph (g)(3), in interior structural fires, the employer shall ensure that:

1910.134(g)(4)(i)

At least two employees enter the IDLH atmosphere and remain in visual or voice contact with one another at all times;

1910.134(g)(4)(ii)

At least two employees are located outside the IDLH atmosphere; and

1910.134(g)(4)(iii)

All employees engaged in interior structural firefighting use SCBAs.

**Note 1 to paragraph (g):** One of the two individuals located outside the IDLH atmosphere may be assigned to an additional role, such as incident commander in charge of the emergency or safety officer, so long as this individual is able to perform assistance or rescue activities without jeopardizing the safety or health of any firefighter working at the incident.

**Note 2 to paragraph (g):** Nothing in this section is meant to preclude firefighters from performing emergency rescue activities before an entire team has assembled.

[1910.134\(h\)](#)

**Maintenance and care of respirators.** This paragraph requires the employer to provide for the cleaning and disinfecting, storage, inspection, and repair of respirators used by employees.

[1910.134\(h\)\(1\)](#)

**Cleaning and disinfecting.** The employer shall provide each respirator user with a respirator that is clean, sanitary, and in good working order. The employer shall ensure that respirators are cleaned and disinfected using the procedures in Appendix B-2 of this section, or procedures recommended by the respirator manufacturer, provided that such procedures are of equivalent effectiveness. The respirators shall be cleaned and disinfected at the following intervals:

[1910.134\(h\)\(1\)\(i\)](#)

Respirators issued for the exclusive use of an employee shall be cleaned and disinfected as often as necessary to be maintained in a sanitary condition;

[1910.134\(h\)\(1\)\(ii\)](#)

Respirators issued to more than one employee shall be cleaned and disinfected before being worn by different individuals;

[1910.134\(h\)\(1\)\(iii\)](#)

Respirators maintained for emergency use shall be cleaned and disinfected after each use; and

[1910.134\(h\)\(1\)\(iv\)](#)

Respirators used in fit testing and training shall be cleaned and disinfected after each use.

[1910.134\(h\)\(2\)](#)

**Storage.** The employer shall ensure that respirators are stored as follows:

[1910.134\(h\)\(2\)\(i\)](#)

All respirators shall be stored to protect them from damage, contamination, dust, sunlight, extreme temperatures, excessive moisture, and damaging chemicals, and they shall be packed or stored to prevent deformation of the facepiece and exhalation valve.

[1910.134\(h\)\(2\)\(ii\)](#)

In addition to the requirements of paragraph (h)(2)(i) of this section, emergency respirators shall be:

[1910.134\(h\)\(2\)\(ii\)\(A\)](#)

Kept accessible to the work area;

[1910.134\(h\)\(2\)\(ii\)\(B\)](#)

Stored in compartments or in covers that are clearly marked as containing emergency respirators; and

[1910.134\(h\)\(2\)\(ii\)\(C\)](#)

Stored in accordance with any applicable manufacturer instructions.

[1910.134\(h\)\(3\)](#)

**Inspection.**

1910.134(h)(3)(i)

The employer shall ensure that respirators are inspected as follows:

1910.134(h)(3)(i)(A)

All respirators used in routine situations shall be inspected before each use and during cleaning;

1910.134(h)(3)(i)(B)

All respirators maintained for use in emergency situations shall be inspected at least monthly and in accordance with the manufacturer's recommendations, and shall be checked for proper function before and after each use; and

1910.134(h)(3)(i)(C)

Emergency escape-only respirators shall be inspected before being carried into the workplace for use.

1910.134(h)(3)(ii)

The employer shall ensure that respirator inspections include the following:

1910.134(h)(3)(ii)(A)

A check of respirator function, tightness of connections, and the condition of the various parts including, but not limited to, the facepiece, head straps, valves, connecting tube, and cartridges, canisters or filters; and

1910.134(h)(3)(ii)(B)

A check of elastomeric parts for pliability and signs of deterioration.

1910.134(h)(3)(iii)

In addition to the requirements of paragraphs (h)(3)(i) and (ii) of this section, self-contained breathing apparatus shall be inspected monthly. Air and oxygen cylinders shall be maintained in a fully charged state and shall be recharged when the pressure falls to 90% of the manufacturer's recommended pressure level. The employer shall determine that the regulator and warning devices function properly.

1910.134(h)(3)(iv)

For respirators maintained for emergency use, the employer shall:

1910.134(h)(3)(iv)(A)

Certify the respirator by documenting the date the inspection was performed, the name (or signature) of the person who made the inspection, the findings, required remedial action, and a serial number or other means of identifying the inspected respirator; and

1910.134(h)(3)(iv)(B)

Provide this information on a tag or label that is attached to the storage compartment for the respirator, is kept with the respirator, or is included in inspection reports stored as paper or electronic files. This information shall be maintained until replaced following a subsequent certification.

1910.134(h)(4)

**Repairs.** The employer shall ensure that respirators that fail an inspection or are otherwise found to be defective are removed from service, and are discarded or repaired or adjusted in accordance with the following procedures:

1910.134(h)(4)(i)

Repairs or adjustments to respirators are to be made only by persons appropriately trained to perform such operations and shall use only the respirator manufacturer's NIOSH-approved parts designed for the respirator;

1910.134(h)(4)(ii)

Repairs shall be made according to the manufacturer's recommendations and specifications for the type and extent of repairs to be performed; and

1910.134(h)(4)(iii)

Reducing and admission valves, regulators, and alarms shall be adjusted or repaired only by the manufacturer or a technician trained by the manufacturer.

1910.134(i)

**Breathing air quality and use.** This paragraph requires the employer to provide employees using atmosphere-supplying respirators (supplied-air and SCBA) with breathing gases of high purity.

1910.134(i)(1)

The employer shall ensure that compressed air, compressed oxygen, liquid air, and liquid oxygen used for respiration accords with the following specifications:

1910.134(i)(1)(i)

Compressed and liquid oxygen shall meet the United States Pharmacopoeia requirements for medical or breathing oxygen; and

1910.134(i)(1)(ii)

Compressed breathing air shall meet at least the requirements for Grade D breathing air described in ANSI/Compressed Gas Association Commodity Specification for Air, G-7.1-1989, to include:

1910.134(i)(1)(ii)(A)

Oxygen content (v/v) of 19.5-23.5%;

1910.134(i)(1)(ii)(B)

Hydrocarbon (condensed) content of 5 milligrams per cubic meter of air or less;

1910.134(i)(1)(ii)(C)

Carbon monoxide (CO) content of 10 ppm or less;

1910.134(i)(1)(ii)(D)

Carbon dioxide content of 1,000 ppm or less; and

1910.134(i)(1)(ii)(E)

Lack of noticeable odor.

1910.134(i)(2)

The employer shall ensure that compressed oxygen is not used in atmosphere-supplying respirators that have previously used compressed air.

1910.134(i)(3)

The employer shall ensure that oxygen concentrations greater than 23.5% are used only in equipment designed for oxygen service or distribution.

1910.134(i)(4)

The employer shall ensure that cylinders used to supply breathing air to respirators meet the following requirements:

1910.134(i)(4)(i)

Cylinders are tested and maintained as prescribed in the Shipping Container Specification Regulations of the Department of Transportation (49 CFR part 180);

1910.134(i)(4)(ii)

Cylinders of purchased breathing air have a certificate of analysis from the supplier that the breathing air meets the requirements for Grade D breathing air; and

1910.134(i)(4)(iii)

The moisture content in the cylinder does not exceed a dew point of -50 deg.F (-45.6 deg.C) at 1 atmosphere pressure.

1910.134(i)(5)

The employer shall ensure that compressors used to supply breathing air to respirators are constructed and situated so as to:

1910.134(i)(5)(i)

Prevent entry of contaminated air into the air-supply system;

1910.134(i)(5)(ii)

Minimize moisture content so that the dew point at 1 atmosphere pressure is 10 degrees F (5.56 deg.C) below the ambient temperature;

1910.134(i)(5)(iii)

Have suitable in-line air-purifying sorbent beds and filters to further ensure breathing air quality. Sorbent beds and filters shall be maintained and replaced or refurbished periodically following the manufacturer's instructions.

1910.134(i)(5)(iv)

Have a tag containing the most recent change date and the signature of the person authorized by the employer to perform the change. The tag shall be maintained at the compressor.

1910.134(i)(6)

For compressors that are not oil-lubricated, the employer shall ensure that carbon monoxide levels in the breathing air do not exceed 10 ppm.

1910.134(i)(7)

For oil-lubricated compressors, the employer shall use a high-temperature or carbon monoxide alarm, or both, to monitor carbon monoxide levels. If only high-temperature alarms are used, the air supply shall be monitored at intervals sufficient to prevent carbon monoxide in the breathing air from exceeding 10 ppm.

1910.134(i)(8)

The employer shall ensure that breathing air couplings are incompatible with outlets for nonrespirable worksite air or other gas systems. No asphyxiating substance shall be introduced into breathing air lines.

1910.134(i)(9)

The employer shall use only the respirator manufacturer's NIOSH-approved breathing-gas containers, marked and maintained in accordance with the Quality Assurance provisions of the NIOSH approval for the SCBA as issued in accordance with the NIOSH respirator-certification standard at 42 CFR part 84.

1910.134(j)

**Identification of filters, cartridges, and canisters.** The employer shall ensure that all filters, cartridges and canisters used in the workplace are labeled and color coded with the NIOSH approval label and that the label is not removed and remains legible.

1910.134(k)

**Training and information.** This paragraph requires the employer to provide effective training to employees who are required to use respirators. The training must be comprehensive, understandable, and recur annually, and more often if necessary. This paragraph also requires the employer to provide the basic information on respirators in Appendix D of this section to employees who wear respirators when not required by this section or by the employer to do so.

1910.134(k)(1)

The employer shall ensure that each employee can demonstrate knowledge of at least the following:

1910.134(k)(1)(i)

Why the respirator is necessary and how improper fit, usage, or maintenance can compromise the protective effect of the respirator;

1910.134(k)(1)(ii)

What the limitations and capabilities of the respirator are;

1910.134(k)(1)(iii)

How to use the respirator effectively in emergency situations, including situations in which the respirator malfunctions;

1910.134(k)(1)(iv)

How to inspect, put on and remove, use, and check the seals of the respirator;

1910.134(k)(1)(v)

What the procedures are for maintenance and storage of the respirator;

1910.134(k)(1)(vi)

How to recognize medical signs and symptoms that may limit or prevent the effective use of respirators; and

1910.134(k)(1)(vii)

The general requirements of this section.

1910.134(k)(2)

The training shall be conducted in a manner that is understandable to the employee.

1910.134(k)(3)

The employer shall provide the training prior to requiring the employee to use a respirator in the workplace.

1910.134(k)(4)

An employer who is able to demonstrate that a new employee has received training within the last 12 months that addresses the elements specified in paragraph (k)(1)(i) through (vii) is not required to repeat such training provided that, as required by paragraph (k)(1), the employee can demonstrate knowledge of those element(s). Previous training not repeated initially by the employer must be provided no later than 12 months from the date of the previous training.

1910.134(k)(5)

Retraining shall be administered annually, and when the following situations occur:

1910.134(k)(5)(i)

Changes in the workplace or the type of respirator render previous training obsolete;

1910.134(k)(5)(ii)

Inadequacies in the employee's knowledge or use of the respirator indicate that the employee has not retained the requisite understanding or skill; or

1910.134(k)(5)(iii)

Any other situation arises in which retraining appears necessary to ensure safe respirator use.

1910.134(k)(6)

The basic advisory information on respirators, as presented in Appendix D of this section, shall be provided by the employer in any written or oral format, to employees who wear respirators when such use is not required by this section or by the employer.

1910.134(l)

**Program evaluation.** This section requires the employer to conduct evaluations of the workplace to ensure that the written respiratory protection program is being properly implemented, and to consult employees to ensure that they are using the respirators properly.

1910.134(l)(1)

The employer shall conduct evaluations of the workplace as necessary to ensure that the provisions of the current written program are being effectively implemented and that it continues to be effective.

1910.134(l)(2)

The employer shall regularly consult employees required to use respirators to assess the employees' views on program effectiveness and to identify any problems. Any problems that are identified during this assessment shall be corrected. Factors to be assessed include, but are not limited to:

1910.134(l)(2)(i)

Respirator fit (including the ability to use the respirator without interfering with effective workplace performance);

1910.134(l)(2)(ii)

Appropriate respirator selection for the hazards to which the employee is exposed;

1910.134(l)(2)(iii)

Proper respirator use under the workplace conditions the employee encounters; and

1910.134(l)(2)(iv)

Proper respirator maintenance.

1910.134(m)

**Recordkeeping.** This section requires the employer to establish and retain written information regarding medical evaluations, fit testing, and the respirator program. This information will facilitate employee involvement in the respirator program, assist the employer in auditing the adequacy of the program, and provide a record for compliance determinations by OSHA.

1910.134(m)(1)

**Medical evaluation.** Records of medical evaluations required by this section must be retained and made available in accordance with 29 CFR 1910.1020.

1910.134(m)(2)

**Fit testing.**

1910.134(m)(2)(i)

The employer shall establish a record of the qualitative and quantitative fit tests administered to an employee including:

1910.134(m)(2)(i)(A)

The name or identification of the employee tested;

1910.134(m)(2)(i)(B)

Type of fit test performed;

1910.134(m)(2)(i)(C)

Specific make, model, style, and size of respirator tested;

1910.134(m)(2)(i)(D)

Date of test; and

1910.134(m)(2)(i)(E)

The pass/fail results for QLFTs or the fit factor and strip chart recording or other recording of the test results for QNFTs.

1910.134(m)(2)(ii)

Fit test records shall be retained for respirator users until the next fit test is administered.

1910.134(m)(3)

A written copy of the current respirator program shall be retained by the employer.

1910.134(m)(4)

Written materials required to be retained under this paragraph shall be made available upon request to affected employees and to the Assistant Secretary or designee for examination and copying.

1910.134(n)

**Effective date.** Paragraphs (d)(3)(i)(A) and (d)(3)(i)(B) of this section become effective November 22, 2006.

1910.134(o)

Appendices. Compliance with Appendix A, Appendix B-1, Appendix B-2, Appendix C, and Appendix D to this section are mandatory.

[63 FR 1152, Jan. 8, 1998; 63 FR 20098, April 23, 1998; 71 FR 16672, April 3, 2006; 71 FR 50187, August 24, 2006; 73 FR 75584, Dec. 12, 2008; 76 FR 33606, June 8, 2011]

<https://www.osha.gov/laws-regs/regulations/standardnumber/1910/1910.134>

# **SECTION 7**

## **Lead Abatement Completion Report (Fillable)**

### **TDEC DSWM Rule 0400-13-01-.01 (6)(f)11 Abatement Report Requirements**

**HUD Guidelines (July 2012) - Chapter 11: Interim Controls**

**HUD Guidelines (July 2012) - Chapter 12: Abatement**

**HUD Guidelines (July 2012) - Chapter 14: Cleaning**



STATE OF TENNESSEE  
 DEPARTMENT OF ENVIRONMENT AND CONSERVATION  
 DIVISION OF SOLID WASTE MANAGEMENT  
 DAVY CROCKETT TOWER, 7<sup>TH</sup> FLOOR  
 500 JAMES ROBERTSON PARKWAY  
 NASHVILLE, TENNESSEE 37243

## ABATEMENT COMPLETION REPORT

**INSTRUCTIONS:** IN ACCORDANCE WITH T.C.A. §§ 11-1-101, 68-131-401 ET SEQ., 4-5-201 ET SEQ. AND THE STATE OF TENNESSEE LEAD-BASED PAINT ABATEMENT [RULE 0400-13-01-.01\(6\)\(f\)](#), SUBMIT THIS COMPLETED REPORT AS WELL AS ALL REQUIRED DOCUMENTS (SEE BELOW) NO MORE THAN FIFTEEN (15) DAYS FOLLOWING THE COMPLETION OF THE ABATEMENT PROJECT THROUGH THE [MYTDEC FORMS ONLINE PORTAL](#). IF NECESSARY, USE EXTRA PAPER.

**NOTE: 0400-13-01-.01(3) STATES** "Completion date" means the date on which all activities on a permitted lead-based paint abatement project requiring the use of certified individuals are complete, including but not limited to the complete disassembly of all removal area barriers, final clearance testing, and disposal of all lead-based paint waste.

**1. PROJECT INFORMATION** 0400-13-01-.01(6)(f)11(ii)

<b>PROJECT ADDRESS</b>	<b>SUPERVISOR/ PROJECT DESIGNER</b>	<b>SUPERVISOR/ PROJECT DESIGNER CERTIFICATION #</b>
<b>ABATEMENT FIRM</b>	<b>ABATEMENT FIRM CERTIFICATION #</b>	<b>ABATEMENT FIRM ADDRESS</b>

**2. ACTIVITY DATES** 0400-13-01-.01(6)(f)11(i, iv)

<b>ABATEMENT START DATE</b>			<b>ABATEMENT COMPLETION DATE</b>		
<b>CLEARANCE TESTING DATE(S)*</b>	1.	2.	3.	4.	5.

**3. CLEARANCE TESTING** 0400-13-01-.01(6)(f)11(iv)

<b>NAME OF CERTIFIED RISK ASSESSOR/INSPECTOR CONDUCTING CLEARANCE</b>	<b>ADDRESS OF CERTIFIED RISK ASSESSOR/INSPECTOR CONDUCTING CLEARANCE</b>	<b>NAME OF RECOGNIZED LABORATORY CONDUCTING ANALYSES</b>

**3. PROJECT PERSONNEL 0400-13-01-.01(6)(f)1**

NAME AND CERTIFICATION #	TITLE	NAME AND CERTIFICATION #	TITLE
1.		5.	
2.		6.	
3.		7.	
4.		8.	

**4. DESCRIPTION OF ABATEMENT 0400-13-01-.01(6)(f)11(vi)**

INCLUDE A DETAILED WRITTEN DESCRIPTION OF THE ABATEMENT, INCLUDING ABATEMENT METHODS USED, LOCATIONS OF ROOMS AND COMPONENTS WHERE ABATEMENT OCCURRED, THE REASON FOR SELECTING ABATEMENT METHODS FOR EACH COMPONENT, AND ANY SUGGESTED MONITORING OF ENCAPSULANTS OR ENCLOSURES. ATTACH ADDITIONAL PAGES OR PROJECT SPECIFICATIONS IF NECESSARY.

ABATEMENT METHODS USED	ROOM/COMPONENT	REASON FOR SELECTING	SUGGESTED MONITORING

**5. REQUIRED DOCUMENTS** 0400-13-01-.01(6)(f)11(i, iii, v)

ATTACH ALL CLEARANCE RESULTS AND A COPY OF THE PROJECT REVIEW ACKNOWLEDGEMENT TO PROCEED OBTAINED FROM THE COMMISSIONER TO THIS REPORT. IF A COMPLETED OCCUPANT PROTECTION PLAN (OPP) WAS NOT SUBMITTED WITH THE ORIGINAL PROJECT NOTIFICATION, ATTACH IT TO THIS REPORT.

	<b>ALL CLEARANCE TEST RESULTS ARE ATTACHED TO THIS REPORT*</b>		
	<b>PROJECT REVIEW ACKNOWLEDGEMENT TO PROCEED IS ATTACHED TO THIS REPORT</b>		
	<b>OCCUPANT PROTECTION PLAN IS ATTACHED TO THIS REPORT</b>		<b>OPP WAS SUBMITTED WITH ORIGINAL NOTIFICATION</b>

\***Copy of clearance testing results** and all soil analyses (if applicable) indicating whether the unit passed or failed. If failed, the measures used to reach clearance must be documented and additional clearance testing results must be included.

**NOTE:** Rule 0400-13-01-.03(1)(a) "Residential Property Renovation" requires each person who performs a renovation of target housing for compensation to provide a lead hazard information pamphlet, [Protect Your Family From Lead In Your Home](#), to the owner and occupant of such housing prior to commencing the renovation. If renovation work occurred in addition to abatement, written acknowledgement that the pamphlet was received can be attached to this report.

**6. WASTE DISPOSAL** 0400-13-01-.01(3)

	<b>WASTE DISPOSAL DOCUMENTATION IS ATTACHED TO THIS REPORT</b>	
<b>WASTE DISPOSAL DATE:</b>		<b>NOTES:</b>

**6. SIGNATURE AND DATE**

This abatement report was prepared by

Name:

Certification number:

\_\_\_\_\_  
Signature

\_\_\_\_\_  
Date



STATE OF TENNESSEE  
DEPARTMENT OF ENVIRONMENT AND CONSERVATION  
DIVISION OF SOLID WASTE MANAGEMENT  
DAVY CROCKETT TOWER, 7<sup>TH</sup> FLOOR  
500 JAMES ROBERTSON PARKWAY  
NASHVILLE, TENNESSEE 37243

## ABATEMENT COMPLETION REPORT

**INSTRUCTIONS:** IN ACCORDANCE WITH T.C.A. §§ 11-1-101, 68-131-401 ET SEQ., 4-5-201 ET SEQ. AND THE STATE OF TENNESSEE LEAD-BASED PAINT ABATEMENT [RULE 0400-13-01-.01\(6\)\(f\)](#), SUBMIT THIS COMPLETED REPORT AS WELL AS ALL REQUIRED DOCUMENTS (SEE BELOW) NO MORE THAN FIFTEEN (15) DAYS FOLLOWING THE COMPLETION OF THE ABATEMENT PROJECT THROUGH THE [MYTDEC FORMS ONLINE PORTAL](#). IF NECESSARY, USE EXTRA PAPER.

**NOTE: 0400-13-01-.01(3) STATES** "Completion date" means the date on which all activities on a permitted lead-based paint abatement project requiring the use of certified individuals are complete, including but not limited to the complete disassembly of all removal area barriers, final clearance testing, and disposal of all lead-based paint waste.

### 1. PROJECT INFORMATION 0400-13-01-.01(6)(f)11(ii)

PROJECT ADDRESS	SUPERVISOR/ PROJECT DESIGNER	SUPERVISOR/ PROJECT DESIGNER CERTIFICATION #
ABATEMENT FIRM	ABATEMENT FIRM CERTIFICATION #	ABATEMENT FIRM ADDRESS

### 2. ACTIVITY DATES 0400-13-01-.01(6)(f)11(i, iv)

ABATEMENT START DATE		ABATEMENT COMPLETION DATE			
CLEARANCE TESTING DATE(S)*	1.	2.	3.	4.	5.

### 3. CLEARANCE TESTING 0400-13-01-.01(6)(f)11(iv)

NAME OF CERTIFIED RISK ASSESSOR/INSPECTOR CONDUCTING CLEARANCE	ADDRESS OF CERTIFIED RISK ASSESSOR/INSPECTOR CONDUCTING CLEARANCE	NAME OF RECOGNIZED LABORATORY CONDUCTING ANALYSES

**3. PROJECT PERSONNEL 0400-13-01-.01(6)(f)1**

NAME AND CERTIFICATION #	TITLE	NAME AND CERTIFICATION #	TITLE
1.		5.	
2.		6.	
3.		7.	
4.		8.	

**4. DESCRIPTION OF ABATEMENT 0400-13-01-.01(6)(f)11(vi)**

INCLUDE A DETAILED WRITTEN DESCRIPTION OF THE ABATEMENT, INCLUDING ABATEMENT METHODS USED, LOCATIONS OF ROOMS AND COMPONENTS WHERE ABATEMENT OCCURRED, THE REASON FOR SELECTING ABATEMENT METHODS FOR EACH COMPONENT, AND ANY SUGGESTED MONITORING OF ENCAPSULANTS OR ENCLOSURES. ATTACH ADDITIONAL PAGES OR PROJECT SPECIFICATIONS IF NECESSARY.

ABATEMENT METHODS USED	ROOM/COMPONENT	REASON FOR SELECTING	SUGGESTED MONITORING

**5. REQUIRED DOCUMENTS** 0400-13-01-.01(6)(f)11(i, iii, v)

ATTACH ALL CLEARANCE RESULTS AND A COPY OF THE PROJECT REVIEW ACKNOWLEDGEMENT TO PROCEED OBTAINED FROM THE COMMISSIONER TO THIS REPORT. IF A COMPLETED OCCUPANT PROTECTION PLAN (OPP) WAS NOT SUBMITTED WITH THE ORIGINAL PROJECT NOTIFICATION, ATTACH IT TO THIS REPORT.

	<b>ALL CLEARANCE TEST RESULTS ARE ATTACHED TO THIS REPORT*</b>		
	<b>PROJECT REVIEW ACKNOWLEDGEMENT TO PROCEED IS ATTACHED TO THIS REPORT</b>		
	<b>OCCUPANT PROTECTION PLAN IS ATTACHED TO THIS REPORT</b>		<b>OPP WAS SUBMITTED WITH ORIGINAL NOTIFICATION</b>

\***Copy of clearance testing results** and all soil analyses (if applicable) indicating whether the unit passed or failed. If failed, the measures used to reach clearance must be documented and additional clearance testing results must be included.

**NOTE:** Rule 0400-13-01-.03(1)(a) "Residential Property Renovation" requires each person who performs a renovation of target housing for compensation to provide a lead hazard information pamphlet, [Protect Your Family From Lead In Your Home](#), to the owner and occupant of such housing prior to commencing the renovation. If renovation work occurred in addition to abatement, written acknowledgement that the pamphlet was received can be attached to this report.

**6. WASTE DISPOSAL** 0400-13-01-.01(3)

	<b>WASTE DISPOSAL DOCUMENTATION IS ATTACHED TO THIS REPORT</b>	
<b>WASTE DISPOSAL DATE:</b>		<b>NOTES:</b>

**6. SIGNATURE AND DATE**

This abatement report was prepared by

Name:

Certification number:

\_\_\_\_\_  
Signature

\_\_\_\_\_  
Date

(6) Work Practice Standards for Conducting Lead-Based Paint Activities: Target Housing and Child- Occupied Facilities.

(f) Abatement and Lead Hazard Reductions.

11. An abatement report and project specifications shall be prepared by a certified supervisor or project designer for single family dwellings or multi-family dwellings with 10 or fewer units. A certified project designer shall prepare an abatement report and project specifications for child-occupied facilities and multi-family dwellings having 11 or more units. The completed abatement report shall be submitted to the Commissioner no more than 15 days following the completion of the abatement project. Any project specifications shall meet the requirements in part (e)3 of this paragraph. The abatement report shall include the following information:

- (i) Start and completion dates of abatement and a copy of the Project Review Acknowledgement to Proceed obtained from the Commissioner;
- (ii) The name and address of each certified firm conducting the abatement and the name of each supervisor assigned to the abatement project;
- (iii) The occupant protection plan prepared pursuant to part 5 of this subparagraph;
- (iv) The name, address, and signature of each certified risk assessor or inspector conducting clearance sampling and the date of clearance testing;
- (v) The results of clearance testing and all soil analyses (if applicable) and the name of each recognized laboratory that conducted the analyses; and
- (vi) A detailed written description of the abatement, including abatement methods used, locations of rooms and components where abatement occurred, the reason for selecting particular abatement methods for each component, and any suggested monitoring of encapsulants or enclosures.

# Chapter 11: Interim Controls

THE BASIC STEPS COMMON TO MOST JOBS – HOW TO DO IT .....	11-5
I. INTRODUCTION.....	11-7
A. When Interim Controls Are Appropriate and When They Are Not.....	11-8
B. The Standard Treatments Option.....	11-8
C. Combinations of Interim Controls and Abatement of Certain Hazards.....	11-10
D. Preventive Measures That Can Be Performed by Residents .....	11-10
II. Basic Practices and Standards Applicable to Interim Control Jobs .....	11-10
A. Preparing a Lead Hazard Control Plan for Multi-family Housing .....	11-10
B. Qualifications of Persons and Firms Performing Interim Controls.....	11-12
C. Small Amounts of Paint Disturbance.....	11-13
D. Lead-Safe Work Practices .....	11-14
E. Pre-Renovation Education.....	11-16
F. Resident Protection and Worksite Preparation During Control Activities .....	11-17
G. Worker Protection .....	11-18
H. Waste Handling.....	11-18
I. Cleanup .....	11-18
J. Clearance.....	11-18
K. Notification to Occupants of the Results of Hazard Evaluation and Control.....	11-19
L. Ongoing Lead-Safe Maintenance .....	11-20
M. Reevaluation .....	11-20
N. Documentation .....	11-20
III. Paint Stabilization .....	11-22
How To Do It .....	11-22
A. Typical Lead Containing Coatings and Their Failures .....	11-23
1. Moisture.....	11-23
2. Aging .....	11-23
3. Mechanical Damage .....	11-23
4. Chemical Incompatibility .....	11-25
5. Poor Surface Preparation.....	11-25
B. Substrate Condition and Repairs.....	11-25
1. Building Envelope Leaks.....	11-25
2. Interior Repairs and Water.....	11-26
3. Water Vapor Management .....	11-27
4. Substrate Repairs.....	11-27
C. General Paint Application Guidelines .....	11-28
1. Appropriate Conditions.....	11-28
2. When Paint Stabilization Will Not Last Very Long.....	11-28

3. General Recommendations for Applying Paint.....	11-28
<b>D. Worksite Preparation .....</b>	<b>11-29</b>
<b>E. Surface Preparation .....</b>	<b>11-29</b>
1. Paint Removal Practices.....	11-30
2. Cleaning Surfaces of Dust and Chips. ....	11-31
<b>F. Priming .....</b>	<b>11-31</b>
1. Oil- and Alkyd-Based Primers.....	11-31
2. Waterborne Primers.....	11-32
<b>G. Top-coats .....</b>	<b>11-32</b>
<b>H. Cleaning and Clearance or Cleaning Verification .....</b>	<b>11-33</b>
<b>I. Maintenance.....</b>	<b>11-33</b>
<b>IV. Treatment of Friction, Impact, and Chewable Surfaces .....</b>	<b>11-34</b>
<b>How To Do It .....</b>	<b>11-34</b>
<b>A. Definition of Terms .....</b>	<b>11-35</b>
1. Friction Surfaces .....	11-35
2. Impact Surfaces .....	11-36
3. Chewable Surfaces .....	11-36
<b>B. Lead Hazard Control Measures .....</b>	<b>11-37</b>
1. Window Systems.....	11-37
2. Door Systems.....	11-40
3. Stair Systems.....	11-41
4. Chewable Surfaces .....	11-41
5. Baseboards and Outside Wall Corners.....	11-42
6. Drawers and Cabinets .....	11-43
7. Porches, Decks, and Interior Floors.....	11-43
<b>V. Dust Removal and Control .....</b>	<b>11-44</b>
<b>How To Do It .....</b>	<b>11-44</b>
<b>A. Introduction.....</b>	<b>11-45</b>
1. Sources and Locations of Leaded Dust .....	11-46
2. Removing Leaded Dust From a Dwelling .....	11-47
3. Creating Cleanable Surfaces and Determining Whether Dust Removal Alone Is Adequate .....	11-48
4. Planning and Preparations.....	11-49
5. Responsibilities of Owners .....	11-50
6. Responsibilities of Contractors.....	11-50
<b>B. Methods of Dust Removal .....</b>	<b>11-51</b>
1. Cleaning Hard Surfaces .....	11-51
2. Removal or Cleaning of Carpets.....	11-54
3. Cleaning Upholstered Furniture .....	11-58

4. Forced Air Systems and Drop Ceilings.....	11-58
5. Resident Protection .....	11-60
C. Follow-up to Dust Removal.....	11-60
VI. Soil Interim Controls.....	11-61
How To Do It .....	11-61
A. Definition of Soil Lead Hazards .....	11-62
B. Temporary and Permanent Soil Treatments.....	11-62
C. Types of Interim Control Measures for Soil .....	11-62
1. Soil Alteration .....	11-63
2. Soil Surface Cover.....	11-63
3. Raised Beds and Other Landscaping Options.....	11-64
4. Land Use Controls .....	11-65
5. Reduction of Soil Tracking into Dwellings .....	11-67
6. Drainage and Dust Controls .....	11-67
D. Making a Plan.....	11-67
E. Guidance on Specifications for Interim Controls of Soil Lead Hazards .....	11-68
F. Monitoring and Maintaining Soil Interim Controls.....	11-68
REFERENCES.....	11-69
FIGURES	
Figure 11.1 Moisture-Related Causes of Paint Failure .....	11-24
Figure 11.2 HEPA Vacuum Sanders .....	11-30
Figure 11.3 Window before and after friction treatment.....	11-35
Figure 11.4 Examples of impact and chewable surfaces.....	11-36
Figure 11.5 Prepare the worksite and pre-clean the window .....	11-37
Figure 11.6 Remove parting bead. ....	11-37
Figure 11.7 Remove the bottom sash, sash weights and stops .....	11-38
Figure 11.8 Remove sash controls/weights.....	11-38
Figure 11.9 Window after removal of sash weights .....	11-38
Figure 11.10 Rebuild damaged sash with filler or putty.....	11-38
Figure 11.11 Wet plane edges of sash to fit new jamb liners .....	11-38
Figure 11.12 Vacuum window again.....	11-38
Figure 11.13 Fit sashes into jamb liners .....	11-39
Figure 11.14 Reinstall sash into jamb .....	11-39
Figure 11.15 Stabilizing paint on doors: Wet planning and wet sanding .....	11-40
Figure 11.16 Before and after stair treatments .....	11-41
Figure 11.17 Covering Stairs with Tread Guards.....	11-42

**Figure 11.18** Shoe Molding Is an Acceptable Impact Surface Treatment for Baseboards... 11-42

**Figure 11.19** Corner Bead Coverings Can Be Used on Outside Corners of Walls..... 11-42

**Figure 11.20** Turning a Window Sill and Trough Into a Smooth and Cleanable Surface..... 11-48

**Figure 11.21** How to Use a HEPA Vacuum ..... 11-52

**Figure 11.22** Changing HEPA vacuum filter ..... 11-54

**Figure 11.23** Carpet with debris and after cleaning..... 11-58

**Figure 11.24** Air vent before and after cleaning ..... 11-59

**Figure 11.25** Clean Air Vent Registers..... 11-59

**Figure 11.26** Walk-Off Mats..... 11-60

**Figure 11.27** Thorny Bushes as a Land Use Control ..... 11-65

**Figure 11.28** Using Fencing as an Interim Control ..... 11-65

**TABLES**

**Table 11.1** Finish Coats for Paint Stabilization..... 11-32

**Table 11.2** Sticky Tape Technique for Removing Loose Paint on Impact Surfaces for Owner/ Occupants or Residents ..... 11-43

**Table 11.3** Potential Sources of Lead-Containing House Dust..... 11-46

**Table 11.4** Major Dust Reservoirs and Potential Dust Traps..... 11-47

**Table 11.5** Rug Cleaning Steps and Approximate Time Per 10 Square Feet..... 11-57

**Table 11.6** Grasses and Their Appropriate Applications ..... 11-66

# Chapter 11: Interim Controls

## The Basic Steps Common to Most Jobs – How to Do It

- 1. Decide on hazard control methods to be used and prepare specifications.** For building components, determine which lead-based paint hazards reported by a risk assessor or presumed to be present will be addressed with interim controls (dust removal, paint stabilization, and/or control of friction/abrasion points) and which will be permanently abated (component replacement, paint removal, enclosure, or encapsulation). (Note that, if renovation or rehabilitation is the intention of the work, some or all of the component replacement may not be abatement, but may be conducted as an interim control. See Appendix 6, regarding the applicable regulations.) For soil lead hazards, decide which interim control or abatement measure is appropriate for the climate, the planned use of the area, and how frequently children under age 6 will use the area. The amount of detail provided in specifications should be commensurate with the size of the job. The specifications should state how any abatement activities and other construction work (e.g., weatherization) will relate to the interim control work. It may be efficient to combine contracts or work orders for interim controls and those for abatement activities in many cases.
- 2. Prepare a lead hazard control plan, especially for multi-family housing.** For a multi-family property in which work must be done in more than 10 dwelling units, the owner, together with a certified risk assessor, planner, or other designer, should develop a site-specific lead hazard control plan. The owner of a smaller property may wish to have a lead hazard control plan developed for that property, as well. The plan should be based on the lead-based paint hazards identified, the feasibility of the control measures, occupancy by young children, and financing. (See Section II.A of this chapter.)
- 3. Determine that the contractor and supervisor are certified to do the work in a lead-safe manner.** Select a contractor that is certified as a renovation firm by the U.S. Environmental Protection Agency (EPA) or the State or Tribe to do renovation work in target housing in the State or Tribal area where the property is located. A property owner or manager using staff to conduct the work must obtain certification as a renovation firm, and ensure that the project obtains certification as a renovator. Workers must be trained and properly supervised to assure that lead-safe work practices are followed on the job. (See Section II.B.) Note that the requirement to use a certified renovation firm and certified renovator do not apply if the work in target housing is minor repair and maintenance work, as defined by EPA; if the work is in HUD-assisted target housing, the requirement does not apply if the work is at or below HUD's *de minimis* threshold (see Section II.C, below).
- 4. Provide pre-renovation education to occupants.** EPA requires contractors to notify residents of the affected dwelling(s) of the work, describing its scope, locations when it is expected to begin and end, and provide residents with the "Renovate Right" pamphlet no more than 60 days before work begins. If the scope, locations or schedule change, provide notification of the change before work beyond that originally described is begun. (See Section II.E, and Appendix 6 for more detail.) Determine if State, Tribal and/or local pre-renovation education requirements apply. (Make a similar determination for other items discussed throughout this Chapter.)
- 5. Prepare the worksite and protect the occupants.** Determine the appropriate worksite preparation and occupant protection measures for the job, based on guidance in Chapter 8. Inform the residents and install the barriers and containment.
- 6. Perform the work.** Perform the work as planned, in accordance with guidance in Sections III, IV, V, and VI.

7. **Handle and dispose of waste correctly.** Wrap or bag all solid waste tightly, store it in a secure area, and dispose of it properly. Liquid waste can usually be disposed of in a sanitary sewer system, but not a storm sewer. Comply with state and local requirements. (See Chapter 10 for further guidance.)
8. **Conduct daily cleanups.** Clean up the work area and pathways used by workers at the end of each work day (or work shift, if work is being done in multiple shifts). (See Chapter 14, sections IV.B and C.)
9. **Conduct final cleanup.** The final cleanup should be started no sooner than 1 hour after completion of the work, to allow time for lead particles to settle. If the area to be cleared may have had high lead levels before the work and/or has rough horizontal surfaces that may make clearance difficult, consider using a pre-clearance screen to be sure the space is ready for clearance or cleaning verification. If the project fails the pre-clearance screen, conduct another final cleanup and pre-clearance screen. If the project fails the second pre-clearance screen, either: (1) complete interim controls and/or re-clean; or (2) conduct the clearance examination or cleaning verification. (For further guidance on cleanup, see Section II.I of this chapter and Chapter 14.)
10. **Clearance.** Have an independent, certified risk assessor, lead-based paint inspector, or sampling technician conduct a clearance examination no sooner than 1 hour after final cleanup to let dust settle (see Chapter 15). If clearance is not achieved, complete interim controls and/or re-clean. Following a successful clearance examination, the property owner should receive documentation to that effect.
  - ◆ Note that the EPA allows certain work areas in housing not covered by HUD’s Lead Safe Housing Rule (24 CFR 35, subparts B–R) to be reoccupied after a visual inspection for residual dust, debris and residue, and a “cleaning verification,” which is a visual comparison of wet disposable cleaning cloths that have been wiped over windowsills, uncarpeted floors, or countertops with a reference cleaning verification card, as a means of determining whether post-renovation cleaning has been properly completed. (See Appendix 6 for more detail.)
  - ◆ Note that the EPA’s cleaning verification requirement does not apply if the work in target housing is minor repair and maintenance work; if the work is in federally-assisted target housing, HUD’s clearance requirement does not apply if the work is at or below HUD’s *de minimis* threshold (see Section II.C, below).
11. **Notification of residents.** The property owner or manager should notify residents of what lead-based paint hazards were controlled and how, and the results of the clearance examination. While residents do not have to be notified for interim control or other renovation work in target housing that is not federally-assisted – only the contractor’s client has to be informed of the results of the cleaning verification and other results of the work – HUD recommends that the residents be notified whether or not the housing is assisted.
12. **Perform ongoing lead-safe maintenance.** The owner should conduct ongoing maintenance and monitoring of interim controls to ensure that they remain in place. (See Chapter 6 for detailed guidance on lead-safe maintenance.) If reevaluation is required by regulation or the hazard control plan for the property, reevaluations by a certified risk assessor should be completed at two-year intervals. (See Section II.M of this chapter and Section VII of Chapter 5.)
13. **Document the work and retain records.** The owner should assure that the work and the clearance examination (or cleaning verification) have been documented, and should maintain records of all lead hazard control, clearance, reevaluation, maintenance and monitoring activities. (See Appendix 6 for record retention requirements.) The owner must turn over all lead-related records the owner has to any new owner before sale of the property as part lead disclosure. (See Section II.N for a list of documents.) The owner must also make disclosure of lead-related documents to tenants before they become obligated under new leases or revised leases (see Appendix 6).

## I. Introduction

Interim controls are intended to make dwellings lead-safe by temporarily controlling lead-based paint hazards. Abatement is intended to permanently control lead-based paint hazards. See Chapter 12 for a detailed discussion of the difference between abatement and interim controls. In Title X of the Housing and Community Development Act of 1992, interim controls are defined as

“... a set of measures designed to reduce temporarily human exposure or likely exposure to lead-based paint hazards, including specialized cleaning, repairs, maintenance, painting, temporary containment, ongoing monitoring of lead-based paint hazards or potential hazards and the establishment and operation of management and resident education programs.”

Interim control measures are fully effective only as long as they are carefully monitored, maintained, and, in some cases, professionally reevaluated. If interim controls are properly maintained, they can be effective indefinitely. As long as surfaces are covered with lead-based paint, however, they constitute potential hazards.

Interim lead hazard control measures include:

- ◆ Repairing all rotted or defective substrates that lead to rapid paint deterioration. (Note that repairing defective building systems that are causing substrate damage may be a prerequisite for effective interim control but is outside the scope of interim control per se).
- ◆ Stabilizing all deteriorated lead-based paint surfaces. Paint stabilization entails removing deteriorating paint, preparing the substrate for repainting, and repainting (see Section III).
- ◆ Making floors and interior window sills and window troughs smooth and cleanable.
- ◆ Eliminating friction surfaces with lead-based paint on windows, doors, stair treads, and floors, when they are generating dust lead hazards (see Section IV).
- ◆ Repairing doors and other building components causing impact damage on painted surfaces, if the paint is lead-based paint (see Section IV).
- ◆ Treating protruding, chewable surfaces, such as interior window sills, where lead-based paint may be present and there is either visual or reported evidence that children are mouthing or chewing them (see Section IV).
- ◆ Dust removal and control – i.e., cleaning surfaces to reduce levels of dust containing lead to acceptable levels, including cleaning carpets, if they are contaminated (see Section V).
- ◆ Covering (with planting, mulch, gravel, or other means) or eliminating access to all bare soil containing excessive levels of lead (see Section VI).

Activities that are required by HUD or EPA are identified in this chapter as being “required” or as actions that “must” be done. Activities that are not required by HUD but are recommended by these *Guidelines* are identified as being “recommended” or as actions that “should” be done. Activities that may be done at the discretion of the owner or manager are identified as “optional.”

### A. When Interim Controls Are Appropriate and When They Are Not

It is easiest and most appropriate to use interim controls when substrates are structurally sound and lead exposure comes primarily from deteriorating paint and excessive levels of lead in household dust and/or soil. Interim controls are also appropriate if the housing unit is slated for demolition or renovation within a few years and the investment in more costly abatement is not merited. In many cases resources will not be available to finance abatement, making interim controls the only feasible approach. (Abatement measures are either literally permanent, in the case of component removal, or are considered by Title X as being permanent because they last for at least 20 years, in the case of enclosure or encapsulation. These latter measures are “permanent” if they are maintained by establishing and implementing an ongoing lead-safe maintenance plan for at least 20 years, and, in the case of encapsulants, the products have a 20-year or longer warranty subject to the implementation of the maintenance plan. Enclosure or encapsulation without such an expected longevity and maintenance plan may be conducted as interim control measures.)

Interim controls are unlikely to be effective if the building has substantial structural defects or if interior or exterior walls, or major components, such as windows and porches, are seriously deteriorated or subject to excessive moisture. Paint cannot be effectively stabilized unless substrates are dry, structurally sound, and waterproof. Other interim control measures, such as window repair, will also not be very effective if structural problems are likely to result in rapid treatment failure. Any structural problems should be repaired before interim controls are implemented. If these problems cannot be repaired, more frequent monitoring will be necessary to identify possible early failures and more frequent hazard controls will probably be needed.

Abatement may be required by federal, state, or local regulations in certain situations; in such situations, interim controls are precluded. For example, HUD requires that public housing authorities abate all lead-based paint in dwelling units undergoing comprehensive modernization. HUD regulations also require that all lead-based paint hazards on a property be abated in the course of rehabilitation projects that use more than \$25,000 of Federal rehabilitation funds per dwelling unit (24 CFR Part 35, Subpart J; see also HUD’s Interpretive Guidance on its Lead Safe Housing Rule, particularly items J3 and J3a, at its [http://portal.hud.gov/hudportal/documents/huddoc?id=DOC\\_25476.pdf](http://portal.hud.gov/hudportal/documents/huddoc?id=DOC_25476.pdf)). Some State and local governments have enacted laws and regulations requiring that certain lead-based paint hazards be abated.

Energy-efficient products (such as energy-efficient doors and windows) should be considered whenever building components are replaced. A source of information on energy efficient products is [www.energystar.gov](http://www.energystar.gov) (click on the “Find ENERGY STAR Products” or similar hotlink).

### B. The Standard Treatments Option

Before controlling lead-based paint hazards, it is necessary to know where they are. This means that a risk assessment (as described in Chapter 5) must be conducted first. However, unless prohibited by State or local law, a property owner may elect to bypass the risk assessment and proceed directly to a set of maintenance and repair activities that will eliminate, at least temporarily, any lead-based paint hazard that might be present. This option is called “standard treatments.” HUD regulations permit standard treatments as an option where interim controls are required in pre-1978 housing receiving Federal assistance, and pre-1978 housing being sold by the Federal government (24 CFR 35.120(a)).

Standard treatments consist of the following activities:

- ◆ Paint stabilization. All deteriorated paint on exterior and interior surfaces should be stabilized, following guidance in Section III of this chapter.
- ◆ Making surfaces smooth and cleanable. All horizontal surfaces, such as floors, stairs, interior window sills and window troughs, that are rough, pitted or porous, should be made smooth and easily cleanable. Minor surface damage may be correctable by spackling and recoating. Otherwise it may be necessary to cover or coat the surface with a material such as metal coil stock, plastic, polyurethane, sheet vinyl, or linoleum.
- ◆ Correcting dust-generating conditions. Conditions causing friction or impact on painted surfaces should be corrected, following guidance in Section IV of this chapter.
- ◆ Treating bare soil. Bare soil should be treated in accordance with guidance in Section VI of this chapter.
- ◆ Safe work practices and worker qualifications. All standard treatments should incorporate safe work practices as described in Section II.D of this chapter. Persons performing standard treatments should have the same training and/or supervision as those performing interim controls, as described in Section II.B.
- ◆ Clearance. A clearance examination should be performed in accordance with Chapter 15 after finishing standard treatments that are larger than HUD's *de minimis* threshold before they are concluded. In housing not receiving federal assistance, EPA requires interim control projects larger than its minor repair and maintenance threshold to have a "cleaning verification" step before they are concluded.
- ◆ Other recommended practices. All other recommended practices applicable to interim controls, as described in Section II, also apply to standard treatments. Also, although HUD regulations do not require treatment of chewable surfaces under the standard treatments option, these *Guidelines* recommend that owners or managers consider covering any protruding painted surfaces with teeth marks if young children under age 6 reside in the unit or frequent the common area. (See Section IV.)

In planning and carrying out standard treatments, owners and contractors should presume that all paint is lead-based paint and all bare soil contains soil lead hazards, unless a certified risk assessor or lead-based paint inspector has determined otherwise. The disadvantage of standard treatments is that unnecessary lead hazard control work may be done. The possible advantage is that the owner may save money by foregoing a risk assessment and can simplify the work of the property manager and the maintenance crew by training and tasking a crew to efficiently perform a routine set of work activities that will be lead-safe whether or not lead-based paint is actually present. Standard treatment options may be appropriate for a well-maintained multi-family property with its own appropriately trained maintenance staff.

When there is a substantial likelihood that some treatable surfaces do not contain lead-based paint, owners who hire risk assessors will usually save money overall because the risk assessment will focus the owners' efforts on confirmed hazards, and avoid unnecessary lead hazard control costs for work on building components that are not coated with lead-based paint.

Some state and local laws prescribe certain treatments in order for the housing unit to qualify as lead-safe. Insurance companies and lenders may also prescribe certain treatments if a property is to qualify for insurance coverage or a loan. In all cases, the property owner should ensure that, at a minimum, the required lead hazard control measures are carried out.

### **C. Combinations of Interim Controls and Abatement of Certain Hazards**

In many dwellings, owners will choose a combination of interim controls *and* abatement. This decision is best made in consultation with a certified risk assessor. For example, it is possible to stabilize deteriorated lead-based paint and remove excess levels of leaded dust (interim controls), and at the same time enclose some lead-based painted surfaces, replace some lead-based painted components, or remove lead-based paint from some surfaces (abatement). Such combinations of interim control and abatement treatments will often be the most cost-effective response to a property owner's lead hazard problem, particularly if carried out when the dwelling unit is vacant.

### **D. Preventive Measures That Can Be Performed by Residents**

There are also a number of preventive measures to minimize the likelihood or severity of lead-based paint hazards that owner-occupants or residents of rental dwellings can carry out. Owners of rental properties should provide residents with educational materials furnished by State or local agencies or lead poisoning prevention organizations that include the following basic information:

- ◆ Children's toys should not be placed beneath windows or near surfaces subject to frequent friction or impact or near deteriorated paint surfaces.
- ◆ If there is a sudden loosening of paint material through friction, impact, or any other reason, occupants should use the sticky tape method to remove loose paint described in Table 11.2.
- ◆ Porch decks, interior floors, and other horizontal surfaces should be wet mopped at least twice a month.
- ◆ A door mat should be placed inside doors with direct access to the outdoors, and thoroughly vacuumed weekly.
- ◆ Instances of deteriorating paint should be reported to management as soon as they are discovered.

## **II. Basic Practices and Standards Applicable to Interim Control Jobs**

This section describes the basic practices and standards that are common to most interim control activities. Later sections of the chapter describe work practices that are specific to particular types of jobs, such as paint stabilization, treatment of friction surfaces, dust removal, and soil lead hazard controls.

### **A. Preparing a Lead Hazard Control Plan for Multi-family Housing**

Conducting interim controls of lead-based paint hazards in multi-family housing presents issues not generally found in single-family housing. In most occupied multi-family developments, it is not feasible, financially or logistically, to carry out hazard control activity in all dwelling units at once. In properties with a relatively small number of dwelling units, it may be possible to proceed unit by

unit and complete the hazard control work quickly. In larger properties, however, decisions must be made as to the order of work in dwelling units and common areas, and perhaps, in rooms or components within dwelling units and common areas. Even when an entire building is vacant and undergoing renovation, hazard control elements of the work must be identified and scheduled. Therefore, it is usually advisable that there be a lead hazard control plan for properties with more than 10 units.

Owners should have an independent certified risk assessor prepare a lead hazard control plan to address lead-based paint hazards identified by the risk assessment. If no risk assessment has been conducted, the specific hazards that are presumed to be present should be addressed by using standard treatments. The plan should prioritize and schedule control measures and any additional hazard evaluations so that available resources are targeted for maximum benefit. Lead hazard control planners or designers may also be helpful in preparing such a plan. In developing the plan, the risk assessor should consult with the property owner to gain insights about the property to determine which strategies will be most appropriate. The goal of this consultation is to combine in the plan the risk assessor's knowledge of lead-based paint hazards with the property owner/manager's knowledge of the particular property – its maintenance history, persistent problems, occupancy profile, capital improvement program, etc.

An owner of a building in good condition may find it more efficient to omit the risk assessment, presume all paint is lead-based paint, and proceed directly to standard treatments. Standard treatments can be performed on a routine basis, at the time of turnover of dwelling units, and during periodic maintenance of units, common areas, and grounds.

In developing a lead hazard control plan, it is reasonable to consider treating units occupied by children under age 6 or by women who have informed the property owner or manager that they are pregnant first. Common play areas, child care centers, or dwelling units serving as child care centers are also candidates for early treatment. It is reasonable to consider the fact that it is less expensive to conduct hazard controls effectively and safely in vacant units than in occupied units.

Thus, it may be appropriate to postpone some hazard control treatments until unit turnover. In order to more quickly and cost effectively reduce childhood exposure to lead in the environment, it is reasonable to consider the relocation of families with young children from housing units with lead-based paint (LBP) hazards to vacant units where any hazards have been controlled.

At a minimum, a lead hazard control plan should include the following elements:

- ◆ A hazard control schedule for all units. Usually units with young children or women who have informed the property owner or manager that they are pregnant should be treated first, followed by other units.
- ◆ A commitment on the part of the owner and manager to ongoing lead-safe monitoring and maintenance as explained in Chapter 6. This should include visual assessments by owner or staff, and control of lead-based paint hazards that are generated during routine maintenance work or normal building aging, what those controls consist of, and how those controls will be implemented.
- ◆ A description of how maintenance workers and other staff will be trained to handle lead-based paint hazards safely and perform lead-safe renovations.

- ◆ Specific measures that will be taken during unit turnover (often paint stabilization, specialized dust removal, the provision of cleanable surfaces on floors, sills, and troughs and some minor building component replacement).
- ◆ A description of who will perform clearance examinations – whether by a certified independent consultant (which is recommended in all situations), or by a designated certified in-house staff (if the work is done by an independent contractor) as allowed under the Lead Safe Housing Rule.
- ◆ A schedule for hazard control actions to be completed in common areas.
- ◆ A schedule for reevaluations by certified risk assessors, if recommended.
- ◆ Designation of an individual, preferably on the staff of the owner or the property manager, who is responsible for issues associated with lead-based paint hazards.

## B. Qualifications of Persons and Firms Performing Interim Controls

Interim control activities frequently disturb lead-based paint (LBP) and take place in areas with excessive levels of dust that contains lead. EPA and OSHA have established regulations that cover these activities, as has HUD for these activities conducted in federally-assisted housing.

1. **EPA RRP Rule**, EPA's Renovation, Repair and Painting (RRP) rule covers renovation projects in assisted and unassisted target housing and child-occupied facilities, unless they are smaller than EPA's minor repair and maintenance threshold. The term "renovation" includes repair and painting; interim control projects are "renovations." The RRP Rule requires a firm performing renovation in target housing to be certified as a lead-safe renovation firm, and an individual certified as a lead-safe renovator to provide on-the-job training for workers used on the project, perform or direct workers to follow the RRP rule's work practice standards, be at the job or available when work is being done, and perform the post-renovation cleaning verification (40 CFR 745, subpart E).

A renovation firm must be certified (licensed) by the State or Tribe where the testing is to be done if the State or tribe has an EPA-authorized renovation certification program. The State or Tribe may have qualification requirements for firms and persons performing interim controls that are different than those of the Federal Government. If the State does not have such a program, the renovation firm must be certified by EPA. The list of EPA-authorized States and tribes is at the EPA's RRP web page <http://www.epa.gov/opptintr/lead/pubs/renovation.htm>; the agencies administering their programs are linked from that page. For other States and Tribal areas, EPA administers the renovation certification program; contact information for the EPA Regional Lead Coordinators is at the Where Your Live web page, <http://www.epa.gov/opptintr/lead/pubs/leadoff1.htm>, which can be reached from a link on the RRP web page. A list of certified renovation firms is available on another link from the RRP web page to [http://cfpub.epa.gov/flpp/searchrrp\\_firm.htm](http://cfpub.epa.gov/flpp/searchrrp_firm.htm). Information on becoming a lead-safe certified firm is at [http://www.epa.gov/opptintr/lead/pubs/lscp-renovation\\_firm.htm](http://www.epa.gov/opptintr/lead/pubs/lscp-renovation_firm.htm).

2. **HUD LSHR**. HUD's Lead Safe Housing Rule (LSHR) requires the workers, as well as the project supervisor, to be trained in HUD-approved lead-safe work practices for work in federally-assisted target housing. This means that the workers and the supervisor must be certified renovators, or, if any of the workers are not certified renovators, the supervisor be a certified lead-based paint abatement supervisor in addition to being a certified renovator. The EPA's

RRP curriculum is HUD-approved for individuals performing interim controls; it meets both HUD interim controls training requirements and EPA's RRP training requirements.

Some States have policies on qualifications for persons performing interim controls that are different than those of the Federal Government. A list of State agencies that operate EPA-authorized programs to regulate lead-based paint activities is at <http://www.epa.gov/lead/pubs/traincert.htm>. The EPA Regional Lead Coordinators oversee the development of lead-poisoning prevention efforts within the Region, including managing the lead certification programs in States which are not authorized to operate their own programs; their contact information is at <http://www.epa.gov/lead/pubs/leadoff1.htm>.

3. **OSHA.** OSHA requires that all potentially exposed workers in the construction industry, which includes most interim control activities, be trained concerning hazards in their workplaces under its rule on Safety Training and Education, 29 CFR 1926.21(b)(2), even if lead exposures are below the action level (see Chapter 9). In addition, OSHA's lead in construction standard, at 29 CFR 1926.62(d)(2)(v)(F), requires hazard communication training on lead for all potentially exposed workers. This provision also requires that employers must provide additional lead-specific training to their workers who are exposed at or above the action level on any single day (also addressed in Chapter 9 and Appendix 6).
4. **Structured On-the-Job Training.** The EPA's Renovation, Repair and Painting (RRP) Rule allows for the certified renovator overseeing a renovation project to conduct on-the-job training (OJT) of workers instead of their becoming certified renovators (40 CFR 745.225(d)(6)(ix). EPA, in the RRP Rule's preamble (73 *Federal Register* 21691-21769, April 22, 2008, at 21721) discussed structured OJT (SOJT) and stated that it had decided not to establish an SOJT program as a requirement for training renovation project workers who are not themselves certified renovators.

These *Guidelines* encourage renovation firms to consider training uncertified workers using SOJT approach, as way to produce consistent, accurate, and comprehensive training outcomes. See Appendix 5.1 for information and references on SOJT.

### C. Small Amounts of Paint Disturbance

As discussed in Chapter 6, unit II.C.3, of these *Guidelines*, EPA and HUD regulations state that lead-safe work practices and clearance are not required if the total amount of paint disturbed by the work is less than a small amount specified by each agency.

**HUD's *de minimis* Threshold.** In its regulations, HUD uses the classical legal term for this minimal amount, "*de minimis*." Requirements pertaining to worker qualifications also do not apply if the amount of work is *de minimis*. HUD's *de minimis* levels under its Lead Safe Housing Rule (LSHR; specifically at 24 CFR 35.1350(d)) are amounts up to:

- (1) 20 square feet on exterior surfaces;
- (2) 2 square feet in any one interior room or space; or
- (3) 10 percent of the total surface area on an interior or exterior type of component with a small surface area (such as window sills, baseboards, and trim).

**EPA's Minor Repair and Maintenance Threshold.** EPA's RRP rule has a larger exemption for minor repair and maintenance work on interiors (6 square feet per room) than HUD's *de minimis* threshold,

but it does not have a small-component aspect, and it limits minor work exempted from its rule to those types that will not cause high levels of dust generation. Specifically, EPA's RRP Rule does not cover minor repair and maintenance activities (40 CFR 745.83) in target housing that disrupt no more than:

- (1) 6 square feet or less of painted surface per room for interior activities, or
- (2) 20 square feet or less of painted surface for exterior activities, and

where none of the work practices prohibited or restricted by that rule (open-flame burning or torching of lead-based paint, using machines that remove lead-based paint through high-speed operation without HEPA exhaust control; and operating a heat gun on lead-based paint at or above 1100 degrees Fahrenheit) are used and where the work does not involve window replacement or demolition of painted surface areas.

**HUD Guidelines Recommendation:** These *Guidelines* recommend, however, that, because much old paint has some lead, the following practices should *always* be observed when disturbing paint in pre-1978 housing and child-occupied facilities, even if the amount of paint to be disturbed is *de minimis*, unless it is known that all layers of paint to be disturbed have been applied after 1977 or the paint is not lead-based paint:

- (1) Never use the prohibited methods of paint removal that are described in Section II.D, below; and
- (2) When disturbing paint in housing *occupied by children of less than 6 years of age and/or women who have informed the property owner or manager that they are pregnant*, always clean the work area thoroughly after finishing, preferably with HEPA vacuuming and wet cleaning, and keep residents and pets out of the work area while work is underway and until after the cleanup, and the clearance or cleaning verification, as applicable, has been passed.

#### D. Lead-Safe Work Practices

Lead-safe work practices are ways to perform paint-disturbing work so that occupants, workers and workers' families, and the environment are protected from exposure to, or contamination from, lead in dust, debris and residue generated by the work. Lead-safe work practices include the following:

1. **Do not use the following paint removal practices except as specified.** Workers should not use the following paint removal methods in HUD-assisted target housing; the methods lettered f and g are permitted in unassisted target housing:
  - a. **Open-flame burning or torching.** This can produce toxic gases that a HEPA filter cartridge on a respirator cannot trap (a second, organic, filter is necessary). This method can create high levels of toxic dust that are extremely difficult to clean up; and it can burn down a house.
  - b. **Operating a heat gun at surface temperatures at or above 1100 degrees Fahrenheit.** Operating heat guns at such high temperatures can release lead dust and fumes and induce large increases in the blood lead levels of young children (Farfel and Chisolm, 1990; also cited by EPA in the preamble to its final rule on Requirements for Lead-Based Paint Activities in Target Housing and Child-Occupied Facilities. 61 *Federal Register* 45777, August 29, 1996, at 45795.)

- c. **Machine sanding or grinding without a HEPA local exhaust control and a shroud.**  
Machine sanding or grinding with both a HEPA local exhaust control attached to the tool, and a shroud that meets the following performance requirement is permissible. The shroud must surround the surface being contacted by the tool with a barrier that prevents dust from flying out around the perimeter of the machine, *and* attached to a HEPA vacuum. However, this work method should be conducted used only by workers trained in its use. Because some dust may still blow out around the perimeter of the machine, workers near the machine should wear half-face respirators (with N100 cartridge) at a minimum. Also, the work area should be completely isolated if the machine is used inside.
- d. **Abrasive blasting or sandblasting without HEPA local exhaust control.** These methods should be used only within an enclosure that contains the spread of dust, chips, and debris, and that has a HEPA exhaust. This work method should be conducted used only by workers trained in its use.
- e. **Manual dry sanding or dry scraping**, except that dry scraping is acceptable in conjunction with heat guns with surface temperature of less than 1100°F, or within one foot of electrical outlets, or when treating defective paint spots totaling no more than 2 square feet in any one interior room or 20 square feet on exterior surfaces.
- f. **Uncontained hydroblasting.** Removal of paint using this method can spread paint chips, dust, and debris beyond the work area containment. Contained pressure washing at less than 5,000 pounds per square inch (PSI) can be done within a protective enclosure to prevent the spread of paint chips, dust, and debris. Water run-off should also be contained. Because contained hydroblasting requires precautions that are beyond the scope of most courses in lead-safe work practices, it should only be used by certified lead abatement workers under the supervision of a certified abatement supervisor.
- g. **Paint stripping in a poorly ventilated space when using a volatile stripper that is a hazardous substance** in accordance with regulations of the Consumer Product Safety Commission (CPSC) at 16 CFR 1500.3 and/or a hazardous chemical in accordance with the OSHA regulations at 29 CFR 1910.1200 or 1926.59, as applicable to the work. (This practice is prohibited by HUD regulations but not explicitly by EPA regulations.)

Stripping with methylene chloride should be avoided. OSHA has found that adults exposed to methylene chloride “are at increased risk of developing cancer, adverse effects on the heart, central nervous system and liver, and skin or eye irritation. Exposure may occur through inhalation, by absorption through the skin, or through contact with the skin.” (62 *Federal Register* 1493 (January 10, 1997)). OSHA’s permissible exposure limit for methylene chloride in air was reduced in 1997 from 500 to 25 parts per million (29 CFR 1910.1052 for general industry, and the identical 29 CFR 1926.1152 for construction). Methylene chloride cannot be detected by odor at the permissible exposure limit, and organic vapor cartridge negative pressure respirators are generally ineffective for personal protection against it.

Alternative paint strippers may be safer but have their own safety and/or health concerns. All paint strippers must be used carefully. Always follow precautions provided by the manufacturer.

It is especially important that persons who use paint strippers frequently, use such chemicals in a well ventilated area. If good ventilation is not possible, professionals equipped with protective equipment should perform the work in accordance with CPSC regulations (16 CFR

1500.3) and /or OSHA's hazard communications standards (29 CFR 1910.1200 or 29 CFR 1926.59) and with any substance-specific standards applicable to the work.

CPSC and EPA recommend that persons who strip paint provide ventilation by opening all doors and windows and making sure there is fresh air movement throughout the room. See the jointly published booklet, *What You Should Know About Using Paint Strippers*, CPSC document 423 (<http://www.cpsc.gov/cpsc/pub/pubs/423.html>), and EPA publication EPA-747-F-95-002 (search at <http://nepis.epa.gov/> for publication number 747F95002).

2. Working wet. Keep the surface damp, except near electrical outlets and fixtures, so sanding, scraping, planing, etc. generate less dust and the dust that is created does not spread as far. When working wet, take care to avoid slippery conditions and electrical shock. Always use Ground Fault Interrupter (GFI) outlets when using power tools. When working on a ladder, do not allow the rungs of the ladder to get wet when spraying or misting. Also, do not get protective plastic sheeting wet; it can become slippery.
3. Protecting occupants and containing dust in the worksite. The worksite should be set up and occupants should be protected in accordance with the guidance in Chapter 8. This guidance varies with the amount of dust that is expected to be generated by the work. Generally, occupants should not be allowed in the work area until after the work is finished and the area is cleaned and either clearance has been passed or cleaning has been verified. Temporary relocation may be necessary. Personal belongings should be moved from the area or covered and sealed. Floors should be protected with plastic sheeting. For dusty jobs, dust should be contained within the room or rooms in which work is conducted by installing plastic sheeting over doors and sealing HVAC vents. Workers should not track dust from the work area to the rest of the dwelling. Waste and debris from the job should be wrapped or bagged and sealed and properly disposed of.
4. Specialized cleaning. After finishing the work, the worksite should be cleaned to assure that the site is free of dust lead hazards and can achieve clearance, or cleaning verification, if applicable. Guidance on cleaning is provided in Section IV of this chapter and Chapter 14. Vacuuming (with HEPA vacuums) and wet cleaning are recommended, and required in most instances.

### **E. Pre-Renovation Education**

While education of the residents, particularly the children's caregivers, is not in itself sufficient to prevent childhood lead poisoning, it can assist residents in reducing the risk that their children will be seriously poisoned. Therefore, education is an important adjunct to any lead hazard control system. See Chapter 6, unit IV.C.6, for information on communicating with residents. See Appendix 6 for information on the EPA's Renovation, Repair, and Painting (RRP) Rule, and HUD's Lead Safe Housing Rule (LSHR), both of which have pre-renovation education provisions.

EPA's RRP rule (most of which is found at 40 CFR Part 745, Subpart E) requires that persons who perform renovation, repair or painting (called, in brief, "renovation") of most pre-1978 housing for compensation provide a lead hazard information pamphlet to owners and residents affected by a renovation within 60 days before beginning the work, describe how, where and when the project will be conducted (and update notify if any of this changes), and, if the work is being conducted in common areas, ensure written notification to each affected unit with the information above and describing how the occupant can obtain the pamphlet, at no charge, from the firm performing the

renovation (40 CFR 745.84). Renovation is defined in the regulation as “the modification of any existing structure, or portion thereof, that results in the disturbance of painted surfaces, unless that activity is performed as part of an abatement” (40 CFR 745.83). Detailed information on implementing pre-renovation education is provided in the EPA’s *Small Entity Compliance Guide to Renovate Right*, a handbook on the RRP rule for contractors, property managers and maintenance personnel working in homes and child-occupied facilities built before 1978 (EPA publication EPA-740-K-10-003; [www.epa.gov/lead/pubs/sbcomplianceguide.pdf](http://www.epa.gov/lead/pubs/sbcomplianceguide.pdf)).

This pre-renovation education requirement does not apply to activities are minor repair and maintenance activities (see section II.C, above), emergency renovations, renovations of components that have been found by a certified lead-based paint inspector to be free of lead-based paint, or renovations of housing that is exempt from Title X. Title X exemptions from “target housing” covered by its regulations include: housing built after 1977, housing that is designated as exclusively for the elderly or for persons with disabilities (provided no child of less than 6 years does resides there), and zero-bedroom units.

The pamphlet that must be distributed is the EPA lead pamphlet, *Renovate Right: Important Lead Hazard Information for Families, Child Care Providers and Schools* (“Renovate Right”), or an alternative state or tribal pamphlet approved for this purpose by EPA. The information contained in the lead renovation pamphlet that is given to owners and occupants before beginning the renovation should be provided in appropriate format(s) to meet the needs of all residents including persons with limited English proficiency and in formats that may be needed for persons who are visually or hearing impaired (Executive Order 13166, derived from Title VI of the Civil Rights Act of 1964).

Copies of “Renovate Right” can be obtained from the National Lead Information Center, at 1-800-424-LEAD (hearing- or speech-challenged individuals may access the NLIC number above through TTY by calling the toll-free Federal Information Relay Service at 800-877-8339), or by downloading it from the EPA’s or HUD’s web site. As of the publication of these *Guidelines*, the pamphlet is available in English and Spanish.

- ◆ On the EPA website, the English version is available at <http://www.epa.gov/lead/pubs/renovaterightbrochure.pdf>, and the Spanish version, at <http://www.epa.gov/lead/pubs/renovaterightbrochure-esp.pdf>.
- ◆ On the HUD website, the English version is available at [http://portal.hud.gov/hudportal/documents/huddoc?id=DOC\\_12531.pdf](http://portal.hud.gov/hudportal/documents/huddoc?id=DOC_12531.pdf), and the Spanish version, at [http://portal.hud.gov/hudportal/documents/huddoc?id=DOC\\_12532.pdf](http://portal.hud.gov/hudportal/documents/huddoc?id=DOC_12532.pdf).

Further information on the Pre-Renovation Education (PRE) Rule, as it has been modified by the RRP Rule, is available at the PRE Rule’s website, [www.epa.gov/lead/pubs/leadrenf.htm](http://www.epa.gov/lead/pubs/leadrenf.htm).

## **F. Resident Protection and Worksite Preparation During Control Activities**

Any activity that disturbs lead-based paint can generate leaded dust. Before beginning paint-disturbing work, workers should set up dust containment to fit the job in accordance with guidance provided in Chapter 8. Whenever dust-generating activities are carried out, residents and particularly young children should stay out of the contained area and should not return until all dust, debris and residue are removed and the containment area or the dwelling unit has been thoroughly cleaned and cleared (see details in Chapter 8). If the work disturbs no more than a *de minimis* amount, described in Section II.C, above, elaborate measures to protect occupants are not

necessary. But, it is always best practice to keep occupants out of the work area until after cleanup, and prohibited methods of paint removal should never be used.

### **G. Worker Protection**

Workers should be protected from exposure to lead by using lead-safe work practices, wearing protective clothing, practicing personal hygiene, and, where these measures are insufficient, using additional engineering controls and, if needed, respiratory protection. Chapter 9 addresses this information in detail.

Some control measures may vary depending on the amount of dust that is expected to be generated by the work. A high dust, paint-disturbing job is defined in Chapter 8 as generally one in which dust caused by the work spreads more than five feet from the work surface. These extensive protections are usually not necessary for very small maintenance jobs. Lead-safe work practices described in Section II.D, above, reduce the amount of dust created by the work and the likelihood of worker exposure.

These protective measures will also help to protect workers' families. Contaminated clothing, shoes or boots brought outside of the worksite, and unwashed hands and other exposed skin surfaces, can result in lead contamination and poisonings from exposure to lead in workers' homes or cars.

### **H. Waste Handling**

EPA has interpreted the household exemption of the Resource Conservation and Recovery Act (RCRA) as applying to all lead-based paint activities, including abatement, interim control, renovation, and remodeling of housing (EPA, 2000x). In 2003 EPA amended its solid waste regulations to codify this policy (EPA, 2003w). A summary fact sheet (publication EPA-530-F-03-007), is available through EPA's website RCRA Online at [www.epa.gov/epawaste/nonhaz/municipal/landfill/lbp\\_fs.pdf](http://www.epa.gov/epawaste/nonhaz/municipal/landfill/lbp_fs.pdf). For these purposes, types of housing included under the household waste exemption include multi-family buildings as well as single-family homes. Nevertheless, these *Guidelines* strongly recommend that persons conducting lead-based paint activities treat bulk waste (e.g., painted architectural components being replaced), paint chips, dust and waste water in accordance with the guidance in Chapter 10.

### **I. Cleanup**

These *Guidelines* recommend cleanup at three stages of paint-disturbing work: (1) before the work begins, (2) during the work, and (3) after completion of the work (the final cleanup). Project supervisors should ensure workers should follow the guidance on cleanup during each stage that is provided in Chapter 14, especially its sections IV.B and C,.

### **J. Clearance**

Clearance examinations (including a visual inspection for residual dust, debris and residue) must be conducted following abatement in target housing. (Chapters 12 and 15 describe abatement and clearance examinations, respectively.) Clearance is required after interim control work in target housing receiving federal assistance, unless the interim control work disturbs less than the HUD-specified *de minimis* amount of paint, described in Section II.C, above, and in Chapter 6, unit II.C.3.

These *Guidelines* recommend clearance in other pre-1978 housing even when not required by regulation, such as in most target housing that is not federally-assisted. For projects in unassisted target housing that are not minor repair and maintenance work, EPA requires a visual inspection for residual dust, debris and residue, followed by either clearance or cleaning verification, a visual comparison of the darkening of wet disposable cleaning cloths by wiping them over windowsills, uncarpeted floors, and countertops with the darkness of a reference cleaning verification card, as a means of determining whether post-renovation cleaning has been properly completed (40 CFR 745.85(b)). (See Appendix 6 for more detail.)

### **K. Notification to Occupants of the Results of Hazard Evaluation and Control**

Two Federal regulations require that occupants of housing be informed about lead-based paint or lead-based paint hazards in their homes.

One is the lead-based paint disclosure regulation (Lead Disclosure Rule) issued jointly by HUD (24 CFR part 35, subpart A) and EPA (40 CFR part 745, subpart F). The Lead Disclosure Rule applies at the time of sale or lease of housing built before 1978; some exclusions apply (see Appendix 6 for more information). The Lead Disclosure Rule also applies at the time of lease renewal, if new information is available. Further information on the disclosure rule is available from HUD and EPA and can be found on the Internet at either [www.epa.gov/lead/pubs/leadbase.htm](http://www.epa.gov/lead/pubs/leadbase.htm) or [http://portal.hud.gov/hudportal/HUD?src=/program\\_offices/healthy\\_homes/enforcement/disclosure](http://portal.hud.gov/hudportal/HUD?src=/program_offices/healthy_homes/enforcement/disclosure).

Relevant information includes the findings of evaluations (i.e., risk assessments, lead-based paint inspections, and other testing), clearance examinations, and actions taken to reduce any hazards (including interim controls, abatement, or standard treatments). This gives residents the information they need to protect themselves from inadvertent exposure to lead in the home.

In addition to the Lead Disclosure Rule, HUD requires, under its Lead Safe Housing Rule (at 24 CFR 35.125), that occupants of housing receiving Federal assistance be notified of the results of evaluations and hazard reduction activities, including clearance.

- ◆ A notice of evaluation or presumption of lead-based paint must be provided within 15 days after the owner or other responsible party receives the evaluation report or makes the presumption. The notice of evaluation must include:
  - (1) a summary of the nature, scope, results, and date of the evaluation,
  - (2) a contact name, including address and phone number, for more information and to obtain access to the complete report and
  - (3) the date of the notice.
- ◆ A notice of hazard reduction activity must be provided within 15 days after the work is completed and the clearance examination report has been received. The notice of hazard reduction must include:
  - (1) a summary of the nature, scope, and results (including clearance) of the work;
  - (2) a contact name for more information, including address and phone number;

- (3) available information on the location of any remaining lead-based paint in the rooms, spaces, or areas where work was performed on a surface-by-surface basis; and
- (4) the date of the notice.

Notices can be provided to the occupants by either:

- ◆ posting and maintaining them in a centrally located common area, with distribution to any dwelling unit where the head of household is disabled; or
- ◆ distributing to each occupied dwelling unit (HUD does not require a signed acknowledgment of receipt).

EPA requires, under its RRP Rule (at 40 CFR 745.86(d)), that, if dust clearance sampling is performed, the renovation firm must provide, within 30 days of the completion of the renovation, a copy of the dust sampling report to the person who contracted for the renovation. These *Guidelines* recommend that the person who contracted for the renovation provide at least a summary of the results to residents of the affected dwelling unit(s) within 15 days after receiving the results.

### **L. Ongoing Lead-Safe Maintenance**

The success of interim control measures depends not only on the adequacy of their initial application, but also on whether they remain effective over time. To remain effective they must be maintained and monitored. Residents should be asked to report deteriorating paint. Property owners, or their agents, should routinely (e.g., annually) visit the property and visually ensure that interim controls remain in place. They should also respond promptly whenever an occupant reports any deteriorating paint. Any failure of interim controls that is identified should be corrected promptly. Common areas should be included in these activities as well as dwelling units. See Chapter 6 for a complete discussion of ongoing lead-safe maintenance.

The HUD Lead Safe Housing Rule (24 CFR Part 35, subparts B through R) requires ongoing maintenance in most target housing receiving HUD assistance, with exceptions for assistance in which HUD does not have an ongoing relationship with the property, e.g., disposition of HUD-owned single-family housing, and rehabilitation other than under the HOME program.

### **M. Reevaluation**

These *Guidelines* recommend, and the Lead Safe Housing Rule requires for most HUD housing assistance programs, that a certified risk assessor conduct a reevaluation if hazard reduction has been conducted to reduce lead-based paint hazards found in a risk assessment or if standard treatments have been conducted (24 CFR 35.1355(b)). The schedule is two year intervals after completion hazard reduction until no lead-based paint hazards are found in two consecutive reevaluations. See Chapter 5, section VII, for guidance on reevaluation.

### **N. Documentation**

Lead hazard evaluation, lead hazard control, and maintenance and monitoring activities associated with interim controls must be documented. Several specific documents are of particular importance. These include:

- ◆ **Risk Assessment and/or Inspection or Testing Reports.** These documents record the findings of any risk assessment or inspection, including any inspection or testing of painted surfaces and the collection and analysis of samples for determination of the lead content in dust, soil, and/or water. A risk assessment that finds no lead-based paint hazards would also justify issuance of a report.
- ◆ **Lead Hazard Control Plan.** This document explains the schedule of hazard control actions in multi-family housing (see Section II.A of this chapter).
- ◆ **Notices to Occupants.** This includes copies of notices to occupants of the results of hazard evaluations (risk assessments, lead-based paint inspections, or paint testing) and the results of lead hazard reduction activities, including clearance (see Section II.K of this chapter).
- ◆ **Description of Work Done.** For future reference, such as to help them implement the lead hazard control plan effectively, owners should have on file a written description of the nature and locations of the work, its starting and ending dates, who performed it, and any specific suggestions for monitoring. Owners or their property managers who performed, or whose employees performed, renovation work covered by the EPA's RRP rule must keep all records necessary to demonstrate compliance with that rule for at least 3 years after the end of the renovation (40 CFR 745.86). If the renovation work was performed by an outside firm, the owner or property manager should arrange to have ongoing access to those records; if the outside firm is planning to dispose of the records at or after the end of the 3-year period, the owner or property manager should arrange to obtain the records for further use in implementing the lead hazard control plan.
- ◆ **Clearance Examination Reports.** These documents record the basis for clearance of the property so that it is ready for occupancy (see Chapter 15). If the housing (or the renovation) is not federally-assisted, the renovation firm's client (typically, the property owner or manager) must be provided a copy of the dust sampling report within 30 days of the completion of the renovation; if the housing (or the renovation) is federally assisted, the property owner or manager must send the report to the affected occupants within 15 days. Cleaning verification is different than clearance; both require documentation.
- ◆ **Spot Test Kit Results Notification.** When spot test kits are used, the firm must notify its client of the manufacturer and model of the test kits used, the description and locations of the components tested, and the test kit results (see Chapter 15).
- ◆ **Reevaluation Reports.** These reports indicate whether the hazard control measures are still in satisfactory condition and whether the dwelling is still in a lead-safe condition. If problems are identified, they prompt corrective action. Reevaluations are performed on a schedule discussed in Section VII of Chapter 5.
- ◆ **Maintenance and Monitoring Log.** This log records the results of the property owner's or property manager's monitoring visits. Any repairs made as a result of these visits, or notices of defects from occupants, should also be recorded.
- ◆ **Other Applicable Records.** Retain records of worker training in lead-safe work practices, any personal air monitoring, if performed, and correspondence with state and local government agencies on matters such as childhood lead poisoning cases, regulatory compliance (e.g., HUD Lead Safe Housing Rule, EPA RRP rule, OSHA Lead in Construction standard, EPA/State/Tribal waste and lead regulations), or other related matters.

### III. Paint Stabilization

#### How To Do It

1. **Fix moisture problems.** Before stabilizing the deteriorated component(s), eliminate any exterior leaks in the building envelope and any interior water leaks that may be causing paint deterioration. Exterior leaks include: roofing leaks, gutter or downspout problems; missing or damaged doors; missing or deteriorated roof flashing; missing opening trim; missing glass in windows; defective or missing caulk and glazing; poor drainage at foundation walls; and loose fasteners. Interior water leaks include: plumbing leaks; clogged condensation drip lines for air conditioners; missing water pans for hot water heaters; inadequately ventilated attic spaces; clogged bathtub drains; missing tile, grout, or caulking in bathtubs; and windows that won't close completely.
2. **Prepare worksite.** Select and implement worksite preparation and occupant protection measures in accordance with guidance in Chapter 8.
3. **Soil sampling (optional).** For exterior paint disturbing work, if the owner or contractor wishes to document that the work does not increase soil lead levels above applicable standards, collect soil samples near the work surfaces before the work begins. These samples need not be analyzed unless samples collected after completion of the work show soil lead levels above applicable standards. This is an optional procedure that is appropriate if pre-work soil samples are not being taken as part of a risk assessment and if there is a special concern regarding the level of lead in the soil.
4. **Repair substrate.** Repair all rotted structural, siding, or railing components; defective plaster; missing door hardware; loose siding or trim; and loose wallpaper.
5. **Remove loose paint.** Prepare surface by wet scraping or wet sanding. Do not use prohibited methods of paint removal: Open-flame burning or torching, operating a heat gun at surface temperatures at or above 1100 degrees Fahrenheit, machine sanding or grinding without a HEPA local exhaust control and a shroud, abrasive blasting or sandblasting without HEPA local exhaust control, manual dry sanding or dry scraping, uncontained hydroblasting, paint stripping in a poorly ventilated space when using a volatile stripper that is a hazardous substance. (See Section II.D, above.)
6. **Other surface preparation.** Clean, degloss, neutralize (if a caustic paint stripper has been used), and rinse surfaces. Surfaces should be dry before priming or repainting.
7. **Select paint.** Select primer and top-coat by considering longevity, moisture resistance, and organic compound content with low volatility. Paint stabilization involves the application of at least two coats (the primer and the top-coat). Use a primer/top-coat system from the same manufacturer to ensure compatibility.
8. **Apply paint.** Apply all paints at appropriate thickness and according to manufacturer's directions. Apply paint only during proper temperature, wind, and humidity conditions. Allow sufficient time for each coat to dry fully.
9. **Cleanup.** Conduct final cleanup (see The Basic Steps Common to Most Jobs – How to Do It, items 8 and 9, on cleanups, above, and Chapter 14). Consider using a pre-clearance screen if the clearance area may have had high lead levels before the work and/or has rough horizontal surfaces that may make clearance difficult.

10. **Clearance.** At the end of the lead hazard control project, have a certified lead-based paint inspector, risk assessor, or sampling technician conduct a clearance examination and provide appropriate documentation. (See The Basic Steps Common to Most Jobs – How to Do It, item 10, on clearance, above, and Chapter 15.) (If clearance is not required and the project is covered by the EPA's Renovation, Repair, and Painting (RRP) Rule, conduct cleaning verification.)
11. **Ongoing lead-safe maintenance.** Perform ongoing lead-safe maintenance in accordance with guidance in Chapter 6. If required by regulation or the property owner or manager's preference, conduct reevaluations every two years in accordance with guidance in Section VII of Chapter 5.

## A. Typical Lead Containing Coatings and Their Failures

The lead in lead-based paint may be found as white pigments (lead carbonate, sulfate, or silicate) or colored pigments (chrome yellow, red lead, gray, and other orange, green, and red pigments).

These pigments were mixed with other components in an oil vehicle, and traditionally thinned with volatile organic solvents and a drying agent. Driers containing lead were used to accelerate the conversion of the liquid coating to a dry film. Paint can fail rather quickly under real life conditions, making ongoing monitoring important. Paint should be quickly, but carefully, stabilized whenever a resident or owner reports that paint is deteriorating.

### 1. Moisture

Oil paints (virtually all lead-based paints are oil paints) form a hard, usually glossy, low permeable and inflexible coating. Water, either in the form of water vapor or liquid, is the single greatest cause of premature paint coating failures. Once a substrate gets wet, the impermeable paint coating is pushed away from the substrate due to vapor formed by heat from the sun or other sources. Repeated soaking/warming cycles result in microscopic failure of the paint and then accelerated failure as more and more openings become available, allowing the substrate to become increasingly wet.

A significant number of homes are poorly constructed, ventilated, or maintained, and allow moisture to be trapped. Twenty-six main causes of premature paint failure from moisture are described in Figure 11.1.

### 2. Aging

All binders in paint age, and some cure over time. This continued curing causes the paint to become too brittle to accommodate the normal expansion and contraction of the substrate, resulting in cracking and peeling. Exterior paints are also attacked by sunlight, which can cause chalking. These slow aging processes mean that even a well managed and protected surface will deteriorate eventually.

### 3. Mechanical Damage

The two basic kinds of mechanical damage (abrasion and impact) can be minimized only by careful management. Paints exhibit tremendous variability in hardness, impact resistance, and abrasion resistance. High performance coatings (e.g., polyamide epoxy, urethane-reinforced alkyls, and epoxy-modified enamels) can withstand over 10,000 more scrubbing cycles than

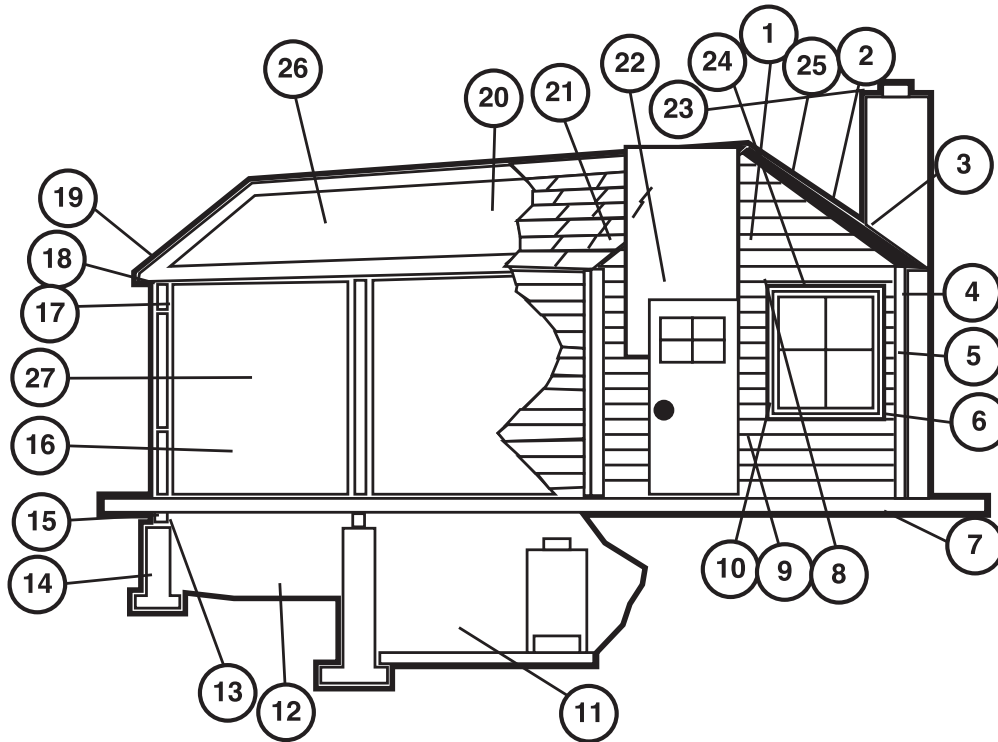

**Key to pointers in Figure 11.1:**

- |   |   |
|---|---|
| <ul style="list-style-type: none"> <li>(1) siding exceeds 14-percent water content</li> <li>(2) no cricket where chimney meets roof</li> <li>(3) no step flashing at side of chimney</li> <li>(4) corner rim not caulked</li> <li>(5) exposed nail heads rusting</li> <li>(6) no window wash at window sill</li> <li>(7) wood contacts earth</li> <li>(8) no drip or gutter at eaves</li> <li>(9) poorly fitted window and door trims</li> <li>(10) waterproof paper not installed behind trim</li> <li>(11) damp, wet cellar unventilated at opposite sides</li> <li>(12) no ventilation of unexcavated space</li> <li>(13) no blocking between unexcavated space and stud wall space</li> <li>(14) no waterproofing or drainage tile around cellar walls</li> </ul> | <ul style="list-style-type: none"> <li>(15) no foundation water and termite sill</li> <li>(16) plaster not dry enough to paint</li> <li>(17) sheathing paper that is not waterproof;</li> <li>(18) vapor barrier omitted – needed for present or future insulation</li> <li>(19) roof built during wet, rainy season without taking due precaution or ventilating on dry days</li> <li>(20) roof leaks</li> <li>(21) inadequate flashing at breaks, corners, roof</li> <li>(22) poorly matched joints</li> <li>(23) no chimney cap</li> <li>(24) no flashing over openings</li> <li>(25) full of openings, loosely built</li> <li>(26) no or inadequate ventilation of attic space</li> <li>(27) plumbing leaks.</li> </ul> |
|---|---|

**FIGURE 11.1** Moisture-Related Causes of Paint Failure

inexpensive flat vinyl paints (Banov, 1978), although some of these paints may not be appropriate for residential use. Failure from impact or friction is often accelerated by the selection of a low performance coating.

#### 4. Chemical Incompatibility

Since oil and water do not mix, oil paints applied over wet substrates will not adhere. The failure may occur within a week, and may cause the paint to be pulled directly from the substrate. Although oil paints stick relatively well on surfaces slightly contaminated with organic material, dirt, and oil, they do not adhere well to fatty or heavily greased surfaces.

Most latex paints do not adhere to chalky, or smooth and glossy paint. Epoxies will fail prematurely when applied over latex coatings and some oil coatings. Some chemical based strippers contain such large amounts of wax and other stabilizers that almost no subsequent coating will maintain good adhesion. If the substrate has been stripped with a caustic paste and not neutralized properly, the highly alkaline pH will cause deterioration of the subsequent paint. On the exterior, salts may build up on the surface of paint in eaves and soffits and prevent paint adhesion. These salts must be removed with water to allow good adhesion.

Portland cement and older plaster substrates are extremely alkaline. They should be aged or etched with mild acid solutions prior to spot sealing with a primer.

#### 5. Poor Surface Preparation

A 100 year-old house, repainted every 8 years, may have at least 12 coats of paint. If surface preparation for only one of those coats was insufficient, paint will peel. Because of the slow erosion of the binder in exterior paints, chalking can cause poor adhesion of new coatings. Chalking results from natural degradation of the organic binder and consequent exposure of unbound pigment particles on the paint surface that rub off easily like chalk. Chalk must be washed off and appropriate primers applied to prevent subsequent failures. Surfaces must be free from oil, grease, and dirt. Paint stripper residue must be removed, either with solvents or alkali cleaners. Hard, glossy oil films require deglossing to allow water borne coatings to adhere properly.

### B. Substrate Condition and Repairs

#### 1. Building Envelope Leaks

The quality and endurance of a paint coating is dependent on the quality of the substrate over which it is applied. The substrate must be dry, structurally sound, and waterproof. Roofing leaks, including porches, gutters, and downspouts, must be fully repaired prior to stabilizing the lead-based paint. Temporary roofing repairs like asphalt patching material, piecing in downspouts and gutters, and short term paint-on coatings are not recommended. Within 4 months, these quick fixes may fail and result in the subsequent failure of the lead-based paint.

In lead-based paint stabilization, the main goal is to create an intact coating that prevents excessive lead exposures. Paint stabilization is most effectively and economically completed after defects, such as the following, have been fully corrected:

- ✦ Damaged or missing roof flashing.
- ✦ Damaged or missing door or window flashing.
- ✦ Siding in contact with soil.
- ✦ Poor drainage at foundation walls.
- ✦ Water running down siding in excessive amounts, due to a broken or clogged gutter or downspout.
- ✦ Missing or deteriorated trim around openings.
- ✦ Missing glass in windows.
- ✦ Missing, damaged, or deteriorated caulking.
- ✦ Loose and rusty fasteners.

## 2. Interior Repairs and Water

The major type of repair that must be completed prior to paint stabilization involves eliminating moisture sources. Plumbing leaks, especially in bathrooms and kitchens, are often the cause of paint failure on the ceilings and walls below. A few major soak/dry cycles can bring the lead-based paint or leach lead salts to the surface.

Because excessively long hot showers in inadequately ventilated bathrooms may result in paint damage, paint stabilization may not last long if these continue to occur routinely. The ventilation in the bathroom may need to be increased; but see Section II.L, below, and Chapter 6, Section III.C.7, about informing residents on their helping avoid this problem.

The following interior defects should be corrected permanently in conjunction with interior lead-based paint stabilization projects:

- ✦ Visible leaks in waste lines, traps, supply lines, or plumbing fixtures above or in rooms undergoing stabilization, or where suspected lead-based paint is present.
- ✦ Clogged condensation drip lines for air conditioners.
- ✦ Water heaters, refrigerators, or washers without pans and overflows above or in rooms undergoing stabilization or where suspected lead-based paint is present.
- ✦ Inadequately ventilated attic spaces.
- ✦ Inadequately ventilated bathrooms, kitchens, and laundry areas.
- ✦ Clogged bathtub drains.
- ✦ Interior windows that are loose or do not close completely.
- ✦ Broken or missing glass in windows.
- ✦ Improper or deteriorated caulking in bathrooms and kitchens.
- ✦ Plugged or blocked weep holes in storm windows.

### 3. Water Vapor Management

Paint exposed to excess water vapor can fail within hours of initial application. Almost all exterior trim flashing and caulking serves a functional purpose by covering seams and joints and keeping out air and water. All missing or deteriorated trim, flashing, and caulking should be replaced prior to stabilizing the deteriorated component(s). In addition to keeping water from entering through the building envelope, it is equally important that the walls and roof be able to dry should they get wet. Exterior cladding and attic spaces should be ventilated to allow the escape of water vapor. Small wedges can be driven between clapboards at each stud (circle vents are of questionable effectiveness), or the walls may be sealed from the inside using caulking and a very low permeable primer. Soffit and ridge ventilation of at least 1 square inch of vent per 300 square inches of ceiling area is recommended. While venting the attic space, it is important also to seal all openings in the ceiling between the interior and the attic so: (1) the attic venting does not pull moisture from the interior into the attic space where it can condense and cause damage or (2) moisture is not pulled from the exterior into the attic and then into the living space when furnace, dryer, and ventilation fans are pulling air out of the interior of the home.

Open cracks in bathrooms and kitchens should be taped with fiberglass mesh wall tape, spackled, and then sealed to eliminate water penetration. Minor repairs to the plaster substrate should be completed, allowed to dry, and sealed with white shellac or acrylic latex.

The following vapor maintenance defects should be permanently corrected prior to stabilizing lead-based paint:

- ◆ Deteriorated or missing caulking or grout at tub and shower surrounds.
- ◆ Painted over vents on siding or roof.
- ◆ Deteriorated or missing caulking that allows air infiltration (e.g., at trim, outlets, light fixtures, pipe penetrations).
- ◆ Uncovered crawl spaces with low permeable vapor barriers. Crawl spaces can be dried by first reducing humidity, removing any standing water, and then applying 6-mil polyethylene plastic sheeting to the floor of the space, especially if it is soil, after all debris has been removed and the soil graded as evenly as possible. The plastic sheeting should go up the side walls of the crawlspace to just above outside grade level. Lapping the seams at least 12 inches or taping the seams is preferred. If there is a heated basement area, it may be possible to eliminate crawlspace vents, insulate the perimeter of the crawlspace, and open the space to the heated basement.

### 4. Substrate Repairs

Prior to stabilizing lead-based paint, defects such as the following should be permanently corrected:

- ◆ Dry rotted or rusty structural, siding, or railing components.
- ◆ Wall and ceiling plaster that is loose from the underlying lath (sagging plaster).
- ◆ Loose siding or trim.
- ◆ Loose wallpaper.

## C. General Paint Application Guidelines

### 1. Appropriate Conditions

Because the guidelines in this chapter have been developed primarily to stabilize and seal lead-based paint, the general requirements for repainting should be rigorously followed. Painters should be professional, skilled, and willing to guarantee their work. Strict adherence to the paint manufacturers' recommendations for air and substrate temperatures, required primers, relative humidity, and recoating time should be conscientiously enforced. The completed primer and top-coat must be applied at the manufacturers' coverage rate, and the total coating thickness should never be thinner than 2.5 mil.

### 2. When Paint Stabilization Will Not Last Very Long

Under certain conditions, paint stabilization will not last very long. These conditions include:

- ◆ When prerequisite repairs are not possible.
- ◆ When there is a high probability of future physical damage. One possible example is walls of a narrow stairwell that have visible physical damage from continual bumping, scratching or abrasion. Enclosure with wood wainscot is an acceptable alternative to paint stabilization (as long as the narrower width still meets code requirements).
- ◆ Lead paint on children's play equipment. Better options are removal of paint or disposal of equipment.
- ◆ Wall surfaces that are structurally unsound.
- ◆ Walls with a layer of wallpaper over or under lead-based paint. If there are areas of wallpaper that are not intact to the substrate, consider covering these with fresh wallpaper after removing and patching loose areas, or steaming off the wallpaper, patching the substrate, and starting anew.
- ◆ Weep holes in storm windows not cleared to allow ventilation and drainage of water.

Paint stabilization will yield the best results when the surface and building system have been properly prepared. If prerequisite repairs cannot be completed before paint stabilization, the reevaluation period should be shortened substantially. The owner's monitoring frequency should also be increased.

### 3. General Recommendations for Applying Paint

- ◆ Paint only when surface and ambient temperatures are between 45°F and 95°F.
- ◆ Do not paint in direct warm sunlight. Very warm temperatures accelerate the drying time of the paint and may compromise the longevity of the paint. Paint after the sun has passed, or so that the paint is nearly dry before the direct sunlight reaches it.
- ◆ Maintain coatings in container at a temperature range of 65°F to 85°F at all times on the job.

- ◆ Paint only when the temperature is expected to stay above freezing.
- ◆ Paint only when wind velocity is below 15 mph.
- ◆ Paint only when relative humidity is below 80 percent.
- ◆ Observe the recommended spread rate for the coating.
- ◆ Tint each coat differently if the same paint is to be used for successive coats to ensure complete coverage.
- ◆ Allow sufficient time for each coat to dry before applying another. Use the same brand for each coat.
- ◆ Allow adequate time for the top-coat to dry before permitting clients to reoccupy the space.
- ◆ Do not put doors back into use until they have dried completely.
- ◆ Do not paint over weep holes in the bottom of storm window systems. If the weep holes are blocked or plugged, drill a hole to permit proper ventilation and drainage of rainwater. Failure to clear weep holes will cause premature paint failure in window troughs.

#### **D. Worksite Preparation**

See Chapter 8, Section III, Worksite Preparation, for subsections B, on interior worksites, C, on exterior work, and/or D, on windows, as applicable to the project.

Soil sampling is an optional procedure, both before and after the work (see Chapter 15). For exterior work, soil samples may be collected before the work begins if the owner or contractor wishes to document that the work does not increase soil lead levels above applicable hazard standards. These samples need not be analyzed until soil samples have been collected *after* the work has been completed, and such post work samples have been analyzed and compared to soil lead hazard standards. If the lead in soil samples collected after the work has been completed are below applicable standards, the samples collected before the work do not need to be analyzed.

#### **E. Surface Preparation**

The recommended approaches to surface preparation are as follows:

- ◆ All loose surface material should be removed by hand treatments (i.e., wet scraping, wet sanding, or dry scraping with HEPA vacuum exhaust attachment).
- ◆ Surface contaminants that prevent adhesion should be eliminated by cleaning (e.g., chemical degreasing, or equivalent household cleaning agent, followed by thorough rinsing).
- ◆ Surface gloss should be eliminated by chemical etching, wet sanding, or HEPA vacuum assisted sanding.
- ◆ Adhesion to the substrate should be enhanced by chemical etching, applying rust inhibitors, spot sealing, and/or wet sanding.

## 1. Paint Removal Practices.

Do not use the prohibited paint removal practices described in Section II.D, above.

**Wet Scraping.** The goal of safe scraping is to minimize the creation of dust while removing loose paint. The best tool for this work is a scraper attached to a HEPA vacuum that very efficiently removes small dust particles generated during scraping.

Large chips that fall to the floor are captured by the puncture resistant, disposable protective sheeting used for floor containment. Continuously misting the surface with water from a small atomizer or garden type sprayer reduces dust generation. A small amount of detergent can be used as a wetting agent. This procedure is best completed by two people – one scraping, the other wetting the surface. Simple dust gathering devices, like a damp rag wrapped around the head of a draw scraper, capture the smallest dust particles while directing the larger paint chips onto the floor containment area.

When working on a ladder, the steps or rungs of the ladder should be kept as dry as possible to avoid slippage. The ladder should not rest on the disposable, impermeable sheeting that is protecting the ground. Slits should be cut through the sheeting so the feet of the ladder can be secured to a firm base, or the feet of the ladder can rest on plywood that is put on top of the protective sheeting. If slits are cut in the protective sheeting, seal them with tape after moving the ladder. Many contractors have found that it is more efficient to rent lifts for high exterior work than to work from ladders.

**Wet Sanding.** When preparing a surface by sanding (especially with fine finishing grits), it is quite possible to contaminate an entire household with fine particles of lead-contaminated dust. Traditional orbital sanding devices may be used *only* in conjunction with a HEPA vacuum filter attachment (see Figure 11.2). Dry sanding should be replaced by wet sanding *except* near electrical circuits.

Any liquid that does not interfere with subsequent paint adherence may be used (e.g., water, Varsol, phosphoric acid etch for iron). Use sponges to wet sand patching material for drywall, plaster, and wood.

Wood, metal, and painted surfaces that require a fine cosmetic finish may be sanded using wet-dry sandpaper and water or an oil paint solvent. Relatively rough surfaces may be finished using wet foam sanding blocks created by dipping a sponge in aluminum oxide grit. These sponge sanders are ideally suited for wet sanding and can be easily cleaned by immersing in a bucket of cleaning solution.

### HEPA Sanders

Sanding generates huge amounts of dust. HEPA sanders are sanders fitted with HEPA vacuum to watch and filter lead-dust as it is created. Use a HEPA sander when sanding lead paint. Limit the use of HEPA sanding to flat surfaces for feathering or finishing only.

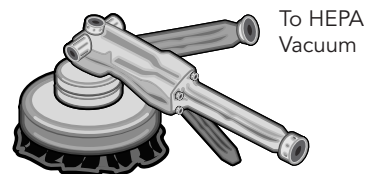
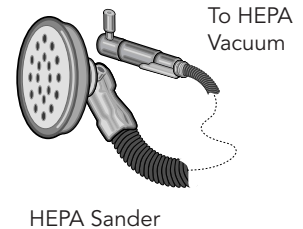

**FIGURE 11.2 HEPA Vacuum Sanders**

Rather than wet sanding or HEPA sanding to degloss paint, the painter may chemically treat the surface with specialized products such as Liquid Sandpaper™, taking care to provide adequate ventilation if volatile substances are released.

## 2. Cleaning Surfaces of Dust and Chips.

Good surface preparation will remove damaged, oxidizing, and deteriorated paint surfaces, but will also create dust and chips that may be leaded. Therefore, after the surface has been allowed to dry, it should be vacuumed to collect surface dust. Prior to applying primer, the surface should be tested for its pH by placing litmus paper against the wet surface. The surface must be rinsed with clear water, or a weak acid solution, until it reaches a pH between 6 and 8 for most new paints.

**Oils, Waxes, and Mold.** While oil and alkyd paints have some tolerance for oil in the substrate, acrylic latex paints will fail prematurely if applied over greasy or oily surfaces. For waxes like crayons and some polishes, a combination of household ammonia and water should be used for cleaning, followed by a thorough rinse. Surfaces in baths and kitchens that may be prone to contamination by airborne grease and oils, or fatty soap can be cleaned with a suitable household cleaner and rinsed thoroughly. Remove mold with soap and water. For guidance on removing mold, two EPA documents may be helpful: *A Brief Guide to Mold, Moisture, and Your Home* (EPA 402-K-02-003) and *Mold Remediation in Schools and Commercial Buildings* (EPA 402-K-01-001) which can be found at [www.epa.gov/mold/moldresources.html](http://www.epa.gov/mold/moldresources.html) (see References for additional ordering information). On some varnished kitchen cabinets, the finished surface may become coated with organic films after extended use. The surface should be cleaned with a nonflammable solvent before painting.

## F. Priming

To maximize the life of a paint job, a system of compatible coatings is necessary. Primers are designed to adhere tightly to the old paint while leaving a rough, bondable surface on the outside. Prior to priming wood and plaster, substrates should be dry. Top quality primers work better, last longer, and treat more substrate types. Consider the following factors when selecting a primer:

- ◆ Type of substrate (e.g., wood, metal, gypsum, masonry).
- ◆ Type of existing substrate coating (e.g., acrylic latex paint, varnish, oil enamel).
- ◆ Interior or exterior application.
- ◆ Top-coat (use manufacturers' recommended primers; use a single manufacturer for both primer and top-coat).

### 1. Oil- and Alkyd-Based Primers

Oil primers are compatible with a system of multiple coats of oil paint over a wood or plaster substrate. The similar solvents used in the old and new paints tend to soften the surface of the paint, creating a better bond. Oil primers are also effective vapor barriers. On the other hand, oil primers contain volatile organic chemicals that can cause adverse health effects and may cost more than waterborne paints. Many states regulate the amount of volatile organic chemicals in paint.

**2. Waterborne Primers**

The most durable waterborne paints are made with an acrylic or acrylic-containing binder. While acrylic latex primers and top-coats are an excellent combination for new wood, they may not be compatible with the lead-based oil paints that cover the substrate. Waterborne paints usually emit less volatile organic compounds and may be less expensive than oil paints.

**G. Top-coats**

To maximize cost-effectiveness and prolong the efficiency of a coating used as a lead hazard control method, it is important to purchase paint with a long lifespan. Inexpensive, low grade paint or special mixes should not be used in lead-based paint stabilization programs. Paints and clear finishes used for paint stabilization jobs require outstanding adhesion, durability, chemical resistance, and flexibility. Therefore, the owner should request the most durable and the highest grade of paint. (See Table 11.1 for finishes typically used for lead-based paint stabilization.)

Marine paints free of lead and mercury, and varnishes (used on boats, docks, etc.) are especially durable and abrasive-resistant. They are formulated with more resin than house paints and the resin is of the highest quality. However, some marine paints are not appropriate for residential use. For example, bottom paints or mildew-resistant paints contain poisons and must be avoided, so that lead is not replaced by another toxic substance.

**Table 11.1 Finish Coats for Paint Stabilization**

Options	Base	Difficulty Level	Comments and Recommendations
Varnish	Oil Alkyd resin, clear finish		Can be touched up very easily.
Acrylic latex	Water	Safest and easiest to use.	May not adhere to alkyd enamels.
Polyurethane resins:			
Alkyd	Oil-volatile organic solvent	Easy to apply. Very durable.	Cannot be touched up without sanding off gloss.
Moisture cured	Volatile organic	Harder to apply.	Needs adequate relative humidity.
Waterborne clear finish	Polyurethane water	Can be hard to apply.	Safer to apply than organic solvent containing coatings.

Source: Adapted from *A Consumer's Guide to Renovation, Repair and Home Improvement*, J. Wiley & Sons, 1991.

High gloss floor and deck enamels offer the next best level of protection. In general, the higher the gloss, the more durable, impact resistant, and moisture resistant the coating. Among types of paint finishes, gloss, semi-gloss, and eggshell coatings are much more resistant to abrasive cleaners and the detergents used in follow-up maintenance procedures than flat finishes.

A satisfactory service life of 4 to 10 years may be achieved with latex and alkyd-based paints (see Cassens and Feist, 1991, regarding 100 percent acrylic latex paint), although much more rapid deterioration can occur under adverse conditions. Low-cost non-acrylic latex may last less than 4 years. The additional material costs (126 percent to 200 percent) of high priced paints and any special primers are minimal when compared to the cost of performing more frequent paint stabilization.

High performance coatings applied properly to ideal substrates may offer a service life of 10 to 25 years. High performance coatings include epoxy-modified alkyds, epoxies, urethanes, epoxy-polyesters, and polyesters. However, these types of coatings should only be selected after consulting the manufacturer as to the specific intended use(s) and after considering the following factors:

- ◆ Possible presence in the new coating of lead, chromate, mercury, or other heavy metals (and other toxic substances).
- ◆ Compatibility with existing paint.
- ◆ Ability to be repainted in future maintenance operations (epoxies and urethanes are difficult to repaint).

Some lead-based paint encapsulants are made out of similar materials and may last longer than paints on some surfaces (see Chapter 13).

## H. Cleaning and Clearance or Cleaning Verification

Containment removal, extensive cleaning, and a clearance examination are required following stabilization and repainting, unless cleaning verification will be undertaken at the end of the work, or unless the size of the project is below the applicable threshold (*de minimis* area for performing clearance, or minor repair and maintenance activities area for performing cleaning verification). These steps are an essential part of the paint stabilization process. (See Section II.I of this chapter and Chapters 14 and 15 for additional discussion of cleaning and clearance.)

For exterior work, if the owner or contractor wishes to document that the work did not increase soil lead levels above applicable standards, soil samples should be collected before work begins and again at clearance. See Section III.D, above.

## I. Maintenance

Immediately after completion of any paint stabilization job, the paint begins the slow process of deterioration from mechanical damage, ultraviolet rays, rain, snow, and wind. A well-prepared substrate, which is primed, and top-coated with premium house paints, can withstand between 4

and 10 years of weathering in temperate climates. At the other extreme, a small scratch in a metal railing located in a coastal town may lead to extensive corrosion and major paint failure within a much shorter time. Assuming a proper paint job, paint life is directly related to the environment to which it is exposed. Cyclical changes in the environment are responsible for the greatest rate of paint destabilization. Rapid changes in temperature, moisture content, and relative humidity cause small stress cracks at joints and between dissimilar materials. Exterior paint life can be extended considerably by annual inspections and maintenance (spot scraping, spot priming, and top-coating deteriorated areas). While a new paint job on interior plaster and wood can last 5 to 10 years with only minor fading, repainting will be required much more frequently in dwellings with more wear and tear. Spot priming and spot top-coating as soon as any deterioration is noticed can extend the life of the interior surfaces.

## IV. Treatment of Friction, Impact, and Chewable Surfaces

### How To Do It

1. **Prepare worksite.** Select and implement the appropriate worksite preparation (see Chapter 8).
2. **Window treatments.** For windows, remove stop bead and parting strip and dispose of properly. Wet scrape deteriorated paint. If the window trough is badly weathered, cap with back-caulked aluminum coil stock. If necessary, repair window weight and pulley system. If further protection is needed, consider installing a new window channel or slide system. Re-glaze if necessary.
3. **Door treatments.** For doors, remove stop from jamb and dispose of properly. Remove door by pulling out hinge pins. Mist and plane door to eliminate friction points. Replace hinges if necessary. Reinstall door and install new stop. If door knob is banging against the wall, install doorstop on floor or wall.
4. **Stair treatments.** For stairs, install a hard, cleanable covering on treads (e.g., rubber tread guards). Carpeting may be used instead, but it must be securely fastened so that it does not cause abrasion. Stabilize paint on banisters, balusters, and newel posts.
5. **Chewable surfaces.** For chewable surfaces such as window sills, remove lead-based paint, or enclose with back-caulked aluminum coil stock, or encapsulate with puncture-resistant epoxy-based or similar material.
6. **Drawers and cabinets.** For drawers and cabinets, remove and replace cabinet doors or remove paint by offsite stripping. Strip paint from drawers and drawer guides or plane impact points and repaint. As an alternative, install rubber or felt bumpers at points of friction or impact.
7. **Floors.** At a minimum, stabilize lead-based paint on porches, decks, and interior floors with polyurethane or high quality abrasion-resistant paint. For a more durable treatment, cover with carpeting, sheet vinyl, or tile, or enclose or replace with new flooring.
8. **Cleanup.** Conduct final cleanup (See The Basic Steps Common to Most Jobs – How to Do It, items 8 and 9, on cleanups, above, and Chapter 14).

9. **Clearance.** Have a certified risk assessor, certified lead-based paint inspector, or certified sampling technician conduct a clearance examination. (See The Basic Steps Common to Most Jobs – How to Do It, item 10, on clearance, above, and Chapter 15.)
10. **Ongoing lead-safe maintenance.** Perform ongoing lead-safe maintenance and monitoring of treatments (see Chapter 6). Reevaluations, if required by regulation or the property owner or manager's preference, should be conducted by certified risk assessors at two year intervals (see Chapter 5).

## A. Definition of Terms

### 1. Friction Surfaces

Friction surfaces are those surfaces covered with lead-based paint that are subject to abrasion, which may generate leaded dust. For a friction surface to be a lead-based paint hazard, as defined by EPA regulations at 40 CFR 745.65(a), there must be a dust lead hazard on the nearest horizontal surface (e.g., floor or interior window sill) underneath or below the friction surface. A dust lead hazard is defined by EPA as equal to or exceeding  $40 \mu\text{g}/\text{ft}^2$  on floors or  $250 \mu\text{g}/\text{ft}^2$  for interior window sills based on wipe samples. See Chapter 5 for more information on identification of friction surface hazards. The most critical friction surfaces are generally those portions of a window that are rubbed when the window is opened and closed (see Figure 11.3). The actual area(s) of adjacent surfaces that rub together should not be painted. This includes the jamb, stop bead, and parting strip, and sometimes the sash. Other common friction surfaces include tight fitting or rubbing doors, cabinet doors

and drawers, stairway treads and railings, and floors or stair treads painted with lead-based paint, including exterior decks and porches.

Friction surfaces on doors and windows will generate less leaded dust when they are kept in good operating condition and in a state of good repair. Friction surfaces can also often be covered with a temporary or permanent covering to eliminate the friction. The covering itself, however, must be abrasion resistant. However, if the component is deteriorated, it may be more cost effective to simply replace it than to attempt to treat friction surfaces (see Chapter 12).



**FIGURE 11.3** Window before and after friction treatment.

## 2. Impact Surfaces

Impact surfaces are surfaces that tend to be bumped or banged repeatedly. To be a lead-based paint hazard that is associated with an impact surface, according to EPA regulations at 40 CFR 745.65(a), the surface must be painted with lead-based paint that is damaged or otherwise deteriorated as a result of impact from a related building component, such as a door knob that knocks into a wall, or a door that knocks against its door frame. Paint that is damaged as a result of misuse, such as from children banging toys against the wall, may be deteriorated paint. If that deteriorated paint is lead-based paint, it is a lead-based paint hazard, but it is not considered an impact surface.

Paint that is damaged as a result of impact can cause small chips of paint to become dislodged and fall to the floor, covering the floor with small amounts of loose lead-contaminated dust and chips. The most common impact surfaces are doors, and door jambs, and door trim (see Figure 11.4).

Impact surface problems can be lessened by re-hanging doors so they open and close properly, and by installing door stops with impact absorbing tips.

## 3. Chewable Surfaces

A chewable surface is an interior or exterior surface that a young child can mouth or chew (see Figure 11.4). A chewable surface is the same as an “accessible surface” as defined in Title X. Hard metal substrates and other materials that cannot be dented by the bite of a young child are not considered chewable.

According to EPA standards at 40 CFR 745.65(a)(3), a chewable surface is a lead-based paint hazard if the surface is coated with lead-based paint and there is evidence of teeth marks. Furthermore, these *Guidelines* take the position that it is not necessary to treat a chewable surface if a child of less than six years of age does not reside in, or regularly visit, the dwelling unit or common area.



**FIGURE 11.4** Examples of impact surfaces (left) and chewable surfaces (right). The window sash has large teeth marks.

## B. Lead Hazard Control Measures

The treatments described below require special construction and cleanup skills that should be implemented by trained personnel only.

### 1. Window Systems

If windows do not open and close smoothly, they may be a significant source of leaded dust and chips in the home. The following paragraphs describe interim control methods of reducing friction surface hazards associated with windows. It is generally acknowledged, however, that windows are the most complex components to treat short of replacement. Window paint tends to deteriorate more rapidly than other painted surfaces due to moisture, variations in temperature, and exposure to the elements. In addition, painted friction surfaces, including the jamb, stop bead, and parting bead may be abraded or "sanded" each time windows are opened and closed. If the wood becomes weathered, dust is trapped and is difficult to remove.

- ◆ Before beginning any window treatment, prepare the worksite in accordance with guidance in Chapter 8. Also, vacuum the interior sill and trough areas to remove any loose paint chips, dust, or debris (see Figure 11.5).
- ◆ For a typical double hung sash, mist the stop bead holding in the lower sash with water. Score the edges with a razor knife to facilitate its removal. Pry off the parting bead (see Figure 11.6), wrap it in plastic, and seal the package with tape for disposal. Next, remove the lower sash (see Figure 11.7), sash weights and stops (see Figures 11.8 and 11.9). The jamb, parting bead, sash, window trough, and peeling trim should be misted with water. Loose and flaking paint should be carefully scraped away, and repairs made (see Figures 11.10 and 11.11). Clean and reinstall the window (see Figures 11.12 to 11.14).



**FIGURE 11.5** Prepare the worksite and pre-clean the window.



**FIGURE 11.6** Remove parting Aboard.



**FIGURE 11.7** Remove the bottom sash, sash weights and stops.



**FIGURE 11.8** Remove sash controls/weights.



**FIGURE 11.9** Window after removal of sash weights.



**FIGURE 11.10** Rebuild damaged sash with filler or putty.



**FIGURE 11.11** Wet plane edges of sash to fit new jamb liners.



**FIGURE 11.12** Vacuum window again.



**Figure 11.13** Fit sashes into jamb liners.



**Figure 11.14** Reinstall sash into jamb.

- ◆ Vacuum all surfaces again, paying particular attention to the window trough. If badly weathered, the window trough should be capped with aluminum coil stock or vinyl (or equivalent), which is first back caulked and then nailed into place.
- ◆ Scrub all surfaces thoroughly with a cleaning agent suitable for leaded dust removal, and rinse with clean water. Any necessary repairs to the weight and pulley system should be made at this time. Reinstall the sash with a new stop bead. Wet scrap any additional paint that was loosened by the hammering. All surfaces should be vacuumed one more time. The new stop bead should be primed and painted.
- ◆ Cleanup the worksite in accordance with guidance in Chapter 14. Generally, the impermeable protective sheeting used to protect the surrounding area should be misted, folded with the dirty surface inside, and placed in a heavy duty plastic bag or wrapped with heavy duty polyethylene sheeting. The bag or package should be sealed and labeled to identify the contents for later disposal. Floor surfaces should be vacuumed beneath the protective sheeting and several feet around the sheeting on each side. Other horizontal surfaces in the containment area should also be vacuumed. The floor and other horizontal surfaces should be wet washed with the cleaning solution and rinsed with clean water. Vacuum any rough horizontal surfaces a final time.
- ◆ For further protection install replacement window channels or slides. Aluminum, vinyl, and polyvinyl chloride (PVC) plastic channels are available (see Figure 11.9). It should be noted, however, that these “jamb liners,” as they are sometimes called, have a very high failure rate. The Evaluation of the HUD Lead-Based Paint Hazard Control Grant Program found that 46 percent of the jamb liners failed three years after installation. (NCHH, 2004) Over half of the failures were attributed to inadequate installation, and 29 percent failed because they were damaged.
- ◆ In this case, both the stop and parting beads should be removed, both sashes taken out, the chain and pulley system disconnected, and the pulleys removed. The old sashes should be planed (with HEPA exhaust), re-caulked, primed, and painted. All other surfaces should receive the same treatment as described above. The jambs should be repainted, the window channels installed with the old sashes, and a new interior stop bead.

- ◆ Covering painted surfaces with coil stock or channel systems may be considered by some State or tribal lead certification agencies to be an enclosure abatement measure combined with interim controls since the whole window system is not enclosed. It should be noted that this approach provides a great deal of flexibility to the property owner. In many cases, it will permit the most cost-effective strategy to be used.
- ◆ If windows are badly deteriorated, it may be more cost effective to replace them, particularly in young children's bedrooms, or in rooms in which young children frequently play.

## 2. Door Systems

Doors present a problem when the doorframe becomes misaligned due to settlement, or when multiple coats of paint reduce frame clearance to the point where the door sticks, rubs, or even chips paint on the door or doorstop when opened and closed (see Figure 11.15). The simplest approach is to re-hang the door so that it no longer rubs against the doorjamb.



**FIGURE 11.15** Stabilizing paint on doors: Wet planing (left) and wet sanding (right) deteriorated paint can create significant amounts of dust.

To accomplish this, prepare the work area in accordance with guidance provided in Chapter 8. Heavily painted stops on jambs can be misted, scored with a knife, and pried loose. The stop should be wrapped in plastic and sealed with tape for disposal. Friction points on the door should be noted. Hinge pins should be removed and the door carefully planed (preferably outside the unit) to eliminate the friction points. (Note: Planing of doors will generate considerable leaded dust and paint chip contamination and may be more easily completed offsite in a controlled environment.) A new stop, if necessary, should be installed and any paint loosened by the hammering should be wet scraped. The new stop and planed areas should be primed, and all surfaces repainted, as described in Section II of this chapter. Cleanup the worksite in accordance with guidance provided in Chapter 14.

### 3. Stair Systems

There are a number of treatments that will control lead hazards on stairs. Installation of rubber tread guards will lessen or eliminate friction on the tread (see Figures 11.16 and 11.17). The tread guards should cover the entire width of the stairs. Do not use precut tread guards if they do not cover the entire width of the stair.

Covering the treads *and* risers with new carpeting can be useful in lessening friction and impact. It is important that carpeting be securely installed and cover the entire width of the stairs, since loose fitting carpeting can cause abrasion and subsequent dust releases. However, since carpeting must be vacuumed thoroughly and frequently to prevent the accumulation of deeply embedded dust lead, installation of a hard, cleanable surface is generally preferable to carpet.

### 4. Chewable Surfaces

The most common chewable surface is a protruding interior window sill, although other components have been chewed by children. The objective in treating such surfaces is to either remove the lead-based paint (using one of the paint removal methods described in Chapter 12) or cover the component with a puncture resistant material. For the latter approach, two options are aluminum coil stock or a hard, puncture resistant encapsulant. Install coil stock as described above for window troughs. Install encapsulants as described in Chapter 13.



FIGURE 11.16 Before and after stair treatments.

### 5. Baseboards and Outside Wall Corners

Damage to baseboards subject to frequent impact can be lessened by installing shoe molding at the bottom of the baseboard (see Figure 11.18). This relatively inexpensive treatment provides a barrier that prevents chair and table legs from actually striking the lead-based painted surface.

If there is existing shoe molding that has been damaged beyond repair, it should be removed by misting the surface, scoring with a razor, and prying the molding loose. The removed molding should be wrapped in plastic and sealed with tape for disposal. Since the baseboard is not necessarily removed, installation of new molding is a combined abatement/interim control measure. New shoe molding should then be back-caulked.

Impact or abrasion of outside corners of walls can be reduced by the installation of a wooden or plastic corner bead (see Figure 11.19).

A rubber tread with metal nosing works well. Rubber nosing that fits snugly on the nose may work if the stairs are not used very often.

- ◆ Enclose risers with thin plywood (like luan plywood) or some other hard material. Whatever you use must fit snugly.
- ◆ Back caulk the edges of treads. Place them and nail or screw them down. Screw or nail the metal nosing on.

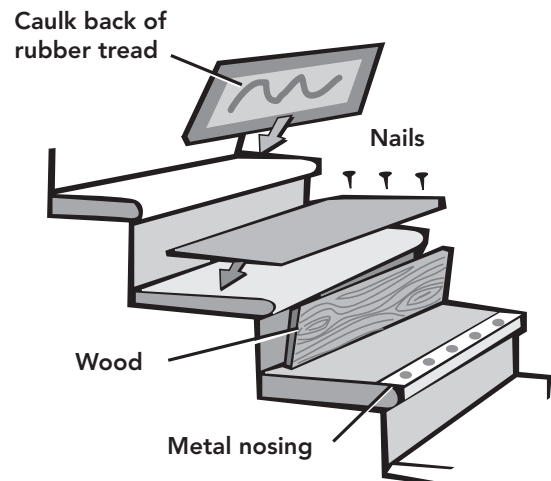

**FIGURE 11.17** Covering Stairs with Tread Guards.

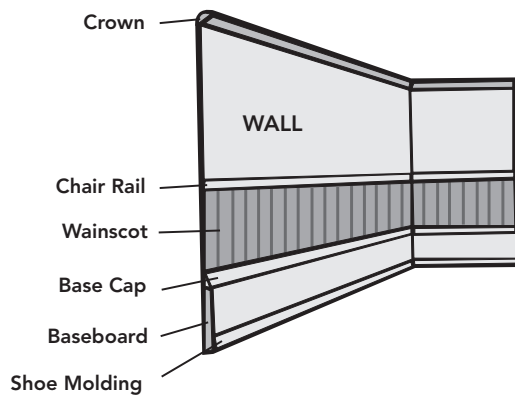

**Figure 11.18** Shoe Molding Is an Acceptable Impact Surface Treatment for Baseboards



**FIGURE 11.19** Corner Bead Coverings Can Be Used on Outside Corners of Walls.

## 6. Drawers and Cabinets

Drawers and cabinets coated with lead-based paint present a potential risk when doors or drawer facings do not fit properly. This is especially important when the cabinet or drawer is used for storing food, eating utensils, or bathroom articles, such as toothbrushes. Cabinet doors can be carefully removed and discarded, or can be stripped offsite and planed where necessary to fit properly, and repainted. These activities should only be performed after all articles are removed from the cabinet and the immediate area is contained. The exterior and interior of the cabinets should be thoroughly cleaned before articles are returned.

Drawers can also be removed and stripped offsite. Drawer covers can be planed at impact points and repainted. Installation of rubber or felt bumpers will also reduce impact with the painted surface of the cabinet.

## 7. Porches, Decks, and Interior Floors

Porches, decks, and interior floors with lead-based paint can be significant generators of paint chips and leaded dust particles through abrasion or impact. At a minimum, the paint should be carefully stabilized and covered with polyurethane or high quality paint. Decks and floors must be smooth enough so that dust can be removed by normal cleaning without special equipment. If funds are available, abatement of floors is strongly recommended, usually through enclosure with new flooring or covering or replacement.

### **Table 11.2 Sticky Tape Technique for Removing Loose Paint on Impact Surfaces for Owner / Occupants or Residents**

1. Place a piece of plastic or paper beneath the area in question.
2. Press a piece of wide sticky tape firmly over the area of loose or chipping paint.
3. Wait a few seconds and then carefully remove the tape, taking the small chips of paint with it.
4. Place the tape in a plastic bag.
5. Carefully fold the piece of plastic or paper that was beneath the area and place it in the bag.
6. Seal the bag and clean the area.
7. Dispose of all waste materials in a secure manner.

## V. Dust Removal and Control

### How To Do It

1. **Dust lead hazard standards.** If dust wipe samples are collected and analyzed by a laboratory, and the level of lead in dust equals or exceeds the following levels the dust should be removed:
  - ◆ Floors (both hard surfaced and carpeted), 40 µg/ft<sup>2</sup>.
  - ◆ Interior window sills, 250 µg/ft<sup>2</sup>.
  - ◆ Window troughs, 400 µg/ft<sup>2</sup>.
  - Bare floors and window components should also be made smooth and cleanable.
2. **Remove dust lead after controlling other hazards.** Correct any known or suspected lead-based paint hazards before dust removal.
3. **Inspect dust traps.** Visually inspect dust traps, such as radiators and floor grates. If visible dust is found, the component should be cleaned.
4. **Communicate with residents.** Distribute educational materials prepared by EPA or State or local government agencies to residents. The owners of rugs, carpets, drapes and upholstered furnishings are responsible for their care. Recommend to the owners that highly contaminated or badly worn items should be discarded. To discard a rug or carpet, mist the surface with water; seal in plastic sheeting, bags, or containers; and discard properly.
5. **Contain work area for carpet removal.** If contaminated carpets are to be removed, the work area should be contained in accordance with guidance for high dust jobs in Chapter 8.
6. **Vacuum and wet clean hard surfaces.**
  - ◆ **Clean all horizontal surfaces, beginning with vacuuming, with a HEPA vacuum, followed by wet cleaning.** A household cleaning agent (vs. a trisodium phosphate solution) is usually adequate. Test the cleaning solution before using it to determine if it will discolor or damage surfaces to be cleaned.
  - ◆ **Sequence of cleaning.** If cleaning an entire dwelling unit, begin dust removal at the top rear room in the dwelling, working forward and down. (Keeping a similar sequence of room cleanings on each floor may be helpful for assuring rooms are not missed.) When practical, clean dirty areas within a room while taking care to avoid spreading dust. Within rooms, start with the highest surface and work down. Clean windows, other dust traps, and finally the floors.
  - ◆ **Take care in removing vacuum filters and/or bags.** If practicable, remove filters and/or bags from the vacuum offsite (not on the property) in a controlled environment. If filters or bags must be replaced onsite in the middle of the job, take the vacuum unit outside the house if practicable, and replace them – and protect the change area – as described in Section IV.B.1, below.
  - ◆ **Wet clean and rinse.** During wet cleaning, replace rags and mops frequently (at least once per dwelling). Use a three bucket system for floors: one for the cleaning solution, one into which the dirty mop or sponge is squeezed, and the other for rinsing. Change the rinse water at least once in each room. Clean until no surface dust is visible. After cleaning, rinse with clean water and a new rag or cloth. Dispose of dirty water in a toilet.

7. **Clean area rugs.** To clean area rugs, HEPA vacuum the top side with a beater bar or agitator attachment at a rate of 1 minute for each 10 square foot area. Fold the rug in half and vacuum the backing of the exposed half of the rug without using the beater bar at a rate of 1 minute per 10 square feet. Vacuum the exposed floor beneath the rug, the bottom of the rug, and the pad (if there is one), and fold the rug back into its original position. Repeat the process for the other half of the rug. Finally, vacuum the top side again with the beater bar at a rate of at least 2 minutes per 10 square feet. To summarize:
  - ◆ Vacuum the top side for 1 minute per 10 square feet.
  - ◆ Vacuum the bottom for 1 minute per 10 square feet.
  - ◆ Vacuum the top again for a final 2 minutes per 10 square feet.
    - This is a total of 4 minutes for every 10 square feet of rug. Also vacuum the bare floor under the rug and the pad, if present.
8. **Clean wall-to-wall carpet.** For wall-to-wall carpeting that cannot be folded over, HEPA vacuum at a rate no faster than 2 minutes per 10 square feet in a side-to-side direction. Follow this by another pass at the same rate in a direction perpendicular to the direction of the first vacuuming, for a total of 4 minutes per 10 square feet. For wall-to-wall carpeting, it is not feasible to clean the floor underneath the carpeting. To attain an even higher level of cleanliness, steam clean the carpet using a regular commercial cleaning system after performing the HEPA vacuuming.
9. **Clean upholstered furnishings.** To clean other upholstered furnishings, vacuum each surface three to five times. Steam cleaning is generally not recommended because it may damage the fabric. However, newer steam cleaners have a water extraction feature to prevent water damage to fabric. Test a small section of the fabric for color fastness before cleaning the entire surface.
10. **Clean drop ceilings and ductwork when necessary.** Clean drop ceilings or the ductwork for forced air systems only when they are expected to be disturbed. Vacuum and wet clean air vents or registers. Replace air filters in the forced air systems at the time of cleaning.
11. **Conduct clearance dust wipe sampling on carpets, rugs or furnishings that were cleaned to determine if the cleaning was effective.** Have a certified lead-based paint inspector, risk assessor, or sampling technician conduct a clearance examination (see The Basic Steps Common to Most Jobs – How to Do It, item 10, on clearance, above, Chapter 15). Repeat cleaning, if necessary.
12. **Ongoing lead-safe maintenance.** Perform ongoing lead-safe maintenance in accordance with guidance in Chapter 6. If required by regulation or the property owner or manager’s preference, conduct reevaluations every two years in accordance with guidance in Section VII of Chapter 5.

### A. Introduction

Dust removal is a type of interim control that involves an initial treatment followed by clearance and re-cleaning as needed. This section provides information on when the removal of leaded dust alone is an appropriate interim control and how to accomplish it. Some dust removal will *always* be an element of interim control measures, either as a stand-alone treatment or as part of cleanup following other work.

### 1. Sources and Locations of Leaded Dust

Lead in settled house dust is the main source of lead exposure for young children. Leaded dust can come from deteriorating lead-based paint on interior and exterior surfaces, abrasion of lead-based paint on friction and impact surfaces, and the disturbance of lead-based paint during maintenance, renovation, or remodeling activities. Leaded dust can also originate from exterior soil or dust. Sources of lead-contaminated soil include weathering or scraping of exterior lead-based paint, past use of lead additives in gasoline, industrial point sources, and demolition and paint removal from buildings and steel structures. Lead-contaminated soil and exterior dust can be tracked inside by humans and pets or carried indoors by wind. Leaded dust can be produced by activities related to hobbies and can be carried home on the clothing of workers exposed to lead. Table 11.3 provides a summary of potential sources of lead in settled house dust.

**Table 11.3 Potential Sources of Lead Containing House Dust.**

Source	Process That Contributes to Lead in House Dust	Key Sites
Interior lead-based paint	Deteriorating paint. Friction/abrasion.	All surfaces. Windows, doors, stairs, floors, carpets, rugs, window coverings (drapes and curtains), mats, and upholstered furnishings.
	Impact.	Door systems, openings, baseboards, corner edges, chair rails, and stair risers.
	Water damage.	Walls, trim, windows, and ceilings
	Planned disturbances: (maintenance activities, repainting, remodeling, abatement).	All surfaces coated with lead-based paint.
Exterior lead-based paint	Tracking (by humans and pets) and blowing of leaded dust from weathered, chalked, or deteriorated exterior lead-based paint; also direct contact with such paint.	All exterior lead-based painted components, including porches and window sills.
	Demolition and other disturbances of lead-based paint on buildings and nearby steel structures.	Exposed soil, sandboxes, sidewalks, and window troughs.
Soil and exterior dust	Tracking (by humans and pets) and blowing of exterior soil/dirt contaminated with lead from deteriorating exterior lead-based paint; past deposition of lead in gasoline.	Exposed soil, sandboxes, sidewalks, streets, and window troughs.
Point sources	Releases from lead related industries (i.e., smelters, battery recycling, incinerators).	Location of point sources.
Hobby activities	Cutting, molding, and melting of lead for bullets, fishing sinkers, toys, and joining stained glass. Use of lead containing glazes and paints. Restoration of lead-based painted items.	Rooms in which hobbies are pursued.
Occupational sources	Transport of lead-contaminated dust from the job to home on clothing, tools, hair, and car or truck.	Vehicles, laundry rooms, changing areas, furniture, and entryway rugs.

Leaded dust can be found on surfaces and in crevices throughout a dwelling. Certain surfaces can act as major reservoirs of lead-contaminated dust, including window troughs, worn floors, carpets, and upholstered furnishings (see Table 11.4). Cleaning carpets, upholstered items, and worn floor surfaces can be difficult due to embedded dust and dirt. Furthermore, lead-contaminated dust can rapidly re-accumulate on household surfaces following dust removal if the conditions contributing to the contamination are not controlled (Tohn, 2002; Lanphear, 2000).

**Table 11.4 Major Dust Reservoirs and Potential Dust Traps.**

Interior		Exterior
Window sills	Upholstered furnishings	Porch systems
Floors/steps	Window coverings	Window troughs
Cracks and crevices	Radiators	Steps
Carpets and rugs	Grates and registers	Exposed soil
Mats	Heating, ventilation, air conditioning filters	Sandboxes

Lead-contaminated dust in carpets and rugs, window coverings (drapes and curtains), mats, and upholstered furnishings is a hazard whether those items are supplied by the owner of the dwelling or by residents. Owners of rental units are responsible for cleaning such items or removing and replacing them only if they belong to the owners. However, the owner should try to provide residents with educational material furnished by a government agency or a qualified lead poisoning prevention organization. Such material should include a warning that carpets and rugs, window coverings, mats, and upholstered furnishings may contain dangerous levels of leaded dust and that those items should be thoroughly cleaned or preferably removed and replaced if they are found to be contaminated.

**2. Removing Leaded Dust From a Dwelling**

Both large, visible dust particles, and small particles not visible to the naked eye, need to be removed (see Figure 11.13).

A combination of vacuuming and wet cleaning is recommended for leaded dust removal. Use of a HEPA vacuum is preferred. Wet cleaning is conducted with a solution of ordinary household detergent. Trisodium phosphate detergent is banned in many states because of potential environmental impacts, so it is not recommended. Even with special equipment

and procedures, leaded dust can be difficult to remove from dust traps, carpets, non-smooth surfaces, and surfaces abated by paint removal methods such as caustic chemicals (Ewers, 1994; Farfel and Chisolm, 1991; Farfel and Chisolm, 1987b).

Workers and residents removing leaded dust should not spread lead from one household surface to another (cross contamination). Avoiding cross contamination requires special knowledge, equipment, procedures, and precautions to protect residents, workers, and the environment. Enhanced routine cleaning procedures, and practices described in this chapter are recommended for use by property owners over ordinary cleaning practices and procedures. This is not to imply that routine housecleaning is totally ineffective. However, in certain cases, routine housecleaning may need to be augmented by the special procedures detailed in this chapter, since smooth surfaces are easier to clean (see Figure 11.20).



**FIGURE 11.20** Turning a Window Sill and Trough Into a Smooth and Cleanable Surface. Window pre-treatment (left) and post-treatment (right).

The cleaning protocol contained in this chapter is different from that used following lead hazard controls and other paint disturbing work, which is described in Chapter 14. The main difference is that only horizontal surfaces (and vertical surfaces undergoing paint stabilization, as explained in Section II of this chapter) are usually cleaned for dust removal. For cleanup following lead hazard control, and other paint disturbing work, walls and horizontal surfaces are cleaned following high dust jobs.

### 3. Creating Cleanable Surfaces and Determining Whether Dust Removal Alone Is Adequate

A risk assessment is recommended to determine whether the removal of leaded dust alone is an appropriate interim control, or whether other interim controls are needed in addition to dust removal. If no lead-based paint inspection or risk assessment has been performed, the property owner should presume that lead-based paint is present on all painted surfaces and that all horizontal surfaces have excessive dust lead levels.

The rest of this section will describe how risk assessors and owners should check floors and floor coverings to plan for dust removal activities.

- ◆ **Check condition of floors.** Smooth and intact floor surfaces, such as vinyl or linoleum sheet goods that still have a smooth finish and wooden floors that have a good finish of sealant (e.g., polyurethane or deck paint) can be effectively cleaned. If a floor surface is not smooth or intact, it will require the application of an appropriate sealer or covering and/or repair in order to make it smooth and cleanable. Examples of non-smooth floor surfaces include floor coverings with worn areas or tears; wood floors with gaps, cracks, splinters, and areas with no sealant coating; unsealed concrete floors; and replacement flooring with no finish treatment (e.g., plywood).
- ◆ **Check carpets, rugs, entryways, and mats.** If possible, small rugs and mats should be machine washed. Wall-to-wall carpets and large area rugs in fair to good condition can be cleaned, or removed and discarded, or replaced (see section on carpets/rugs below). Consider discarding rugs, carpets, and mats that are at the end of their useful lives, since cleaning may not be effective (see below for precautions on removal of carpets) (Ewers, 1994; CH2MHILL, 1991).
- ◆ **Check for other potential dust traps.** In addition to carpets, rugs, and mats, other potential dust traps include radiators, floor grates and registers, drapes, blinds, and upholstered furnishings. These items should be included in the plan for dust removal. In rental properties some of these items may not belong to the building owner. Owners are responsible for the items they own, while residents are responsible for their own property. However, it may be in everyone's best interest to include all of these items in the dust removal plan.

#### 4. Planning and Preparations

Once it has been determined that dust removal is an appropriate approach, the owner should determine if the dwelling unit will be occupied or vacant while the dust removal is occurring. Dust removal work may be performed by contractors, maintenance staff, or homeowners. Individuals performing the work should be properly equipped and trained in dust removal.

If dwelling units are occupied, the owner should coordinate with residents to ensure that the roles of all involved in the process are clear. The job should be organized so that dust removal work is performed in 1 day to minimize inconvenience to residents. Additional personnel and equipment may be required to perform simultaneous work in multiple rooms.

**Role of residents.** See Section I.D, above, regarding preventive measures that can be performed by residents.

Owners should provide residents with educational materials prepared by public agencies that indicate how residents can help in removing leaded dust. The materials should indicate that residents should perform the following tasks regarding property the residents own before the professional dust removal occurs:

- ◆ Wet wash all cleanable toys the residents own.
- ◆ Store all loose personal belongings that need not be professionally cleaned in boxes, closets, or drawers to provide easy access to floors and other surfaces during dust removal.
- ◆ Remove drapes and curtains the residents own and collect any washable area rugs the residents own for cleaning. Clean or arrange for cleaning of these items and store them in sealed plastic bags, or have the cleaners keep them until after the housing owner's lead dust cleaning work is completed.

- ◆ Wash blankets known to have been unprotected during renovation or remodeling activity that disturbed lead-based paint.
- ◆ Wash or dust un-upholstered furniture the residents own using disposable cloths and spray polish.
- ◆ Change filters in heating and air conditioning units, except where routinely performed by the property manager.

## 5. Responsibilities of Owners

Owners should perform the following tasks prior to dust removal:

- ◆ Attempt to schedule dust removal when the dwelling is vacant (such as during unit turnover).
- ◆ If the unit will be occupied, notify residents of the date dust removal will occur.
- ◆ Provide a written notice/flyer from the local health agency with information on resident responsibilities for preparation and cleaning.
- ◆ Provide for the safety of occupants.
- ◆ Arrange for dust removal of wood or metal components of windows, built in shelving, radiators, floors, porches, owner supplied carpets and rugs, window coverings, mats, upholstered furnishings, and other dust traps.
- ◆ Provide and install cleanable “walk-off” mats at interior entryways. This will help residents control exterior leaded dust that may be tracked into the home (Roberts, 1991).
- ◆ Ensure that dust removal contractors comply with contract specifications. Large multi-family contracts may require an onsite monitor.
- ◆ Obtain written authorization from residents for dust removal where legal authority does not exist for such activity.
- ◆ Arrange for clearance examination.

## 6. Responsibilities of Contractors

Contractors or maintenance staff should perform the following tasks prior to and during dust removal (City of Toronto, 1990):

- ◆ Coordinate with residents and owners or managers of property.
- ◆ Cooperate with the client’s independent, onsite inspector or risk assessor or other authorized project monitor who may be present on large, multi-family dust removal projects.
- ◆ Perform work according to contract/work specifications. In the case where the owner’s maintenance staff are performing the work, the owner is responsible for the following (otherwise the contractor is responsible).

- ◆ Ensuring that workers are properly trained and protected (see Chapter 9).
- ◆ Providing all safety and special cleaning equipment and supplies.
- ◆ Taking precautions to minimize damage to residents' belongings.
- ◆ Moving major furnishings within rooms to facilitate thorough cleaning.
- ◆ Responding to residents' questions, complaints, and concerns.

## **B. Methods of Dust Removal**

The objective of any dust removal strategy is to provide a dwelling unit or common area in which the dust lead levels on all horizontal surfaces are less than the clearance levels. Any cleaning method carried out by a property owner is satisfactory if it meets this performance standard and if workers and occupants are fully protected. The procedures in the following pages describe how best to meet that performance standard.

The dust removal strategy presented in this section focuses on horizontal surfaces and dust traps that have accumulations of surface dust and embedded dust. Contractors and owners must use judgment in determining whether walls should be washed. Embedded dust is dust that is trapped within a fiber matrix (such as carpeting), in cracks and crevices (of wooden floors), under carpets, on greasy surfaces, or ground into surfaces. A combination of vacuuming – a HEPA vacuum is required – and wet cleaning is recommended to remove both surface and embedded leaded dust from household surfaces. For upholstered furnishings vacuuming alone is generally recommended.

### **1. Cleaning Hard Surfaces**

The standard dust removal procedure for hard surfaces and components (e.g., hardwood floors and window components) is HEPA vacuuming followed by wet cleaning. One study found that vacuuming hard surfaces at a rate slower than 1 minute per square meter (approximately 10 square feet) did not remove substantially more leaded dust from hard surfaces than faster methods (Ewers, 1994). Therefore, no speed or time restrictions are necessary for hard surfaces (although such restrictions are appropriate for carpeted surfaces, as detailed below). On hard surfaces vacuums should be passed over the entire surface with overlapping strokes using normal speed.

General all-purpose household cleaners have been found to be effective for wet cleaning. Although lead specific cleaners may also be effective, one study found them to be no more effective than all purpose cleaners (Lewis et al. 2006). Trisodium phosphate is not recommended. Not only has it been banned in some areas because of negative effects on the ecology of aquatic systems but research indicates that phosphate content is not associated with effectiveness in removing lead-contaminated dust from residential surfaces (EPA, 1997a; EPA, 1998; Lewis et al 2006). Research also indicates that the effort put into the cleaning, i.e., the amount of pressure applied to the surface and the thoroughness of the cleaning, may be more important than the choice of cleaning agent (EPA, 1997a). Whenever a wet cleaner is used, a small area of the surface should be tested to make sure that it does not damage the surface or its coloring. If so, another wet cleaner should be used.

**General work practices**

- ◆ Clean from top to bottom. HEPA vacuum before wet cleaning. On multistory dwellings, start at the top level in the rear room and work in one direction toward the front. Then repeat the process on the remaining floors in sequence. Within a room, start with the highest horizontal surfaces and work down. This will typically result in the following cleaning sequence: tops of window heads, tops of sashes, mullions, and interior and exterior window sills and troughs. Clean dust traps such as radiators, followed by baseboards, and finally floors, vents/registers, and horizontal components of the ventilation ducts that can be easily reached. When practical, work from clean areas to dirty areas to minimize the spread of leaded dust to clean areas. It is usually not necessary to clean walls and ceilings for dust removal unless those surfaces have undergone paint removal or paint stabilization, or substantial leaded dust has been created in the course of other work.
- ◆ When vacuuming, use crevice and brush tools where appropriate.
- ◆ If possible, place the HEPA vacuum unit on a smooth, hard surface that has been cleaned, or on clean, durable, polyethylene sheeting rather than on a carpet. Vacuum exhaust, even on HEPA vacuums, can disperse dust when the exhaust airstream disturbs settled dust on a surface. A HEPA vacuum that exhausts air from the top or side, rather than the bottom, helps to minimize dust dispersal. (see Figure 11.21).
- ◆ Use disposable cleaning cloths or sponges. Be prepared to dispose of them during the cleaning process and replace them with new ones.
- ◆ When cleaning household surfaces other than floors, the cleaning solution may be mixed in a plastic jug and poured directly onto sponges or cloths (EPA, 1992a). This procedure is designed to minimize the contamination of the cleaning solution with leaded dust. Frequently rinse the sponge/cloth in a bucket of clean water.
- ◆ For floors, a three bucket system is recommended to minimize the potential for spreading leaded dust from one location to another. The cleaning solution should be mixed in one bucket. Dirty water is squeezed into a second bucket. A third bucket should contain rinse water for the mop head. Frequently, at least once per room, change the rinse water in the bucket. Use a string mop

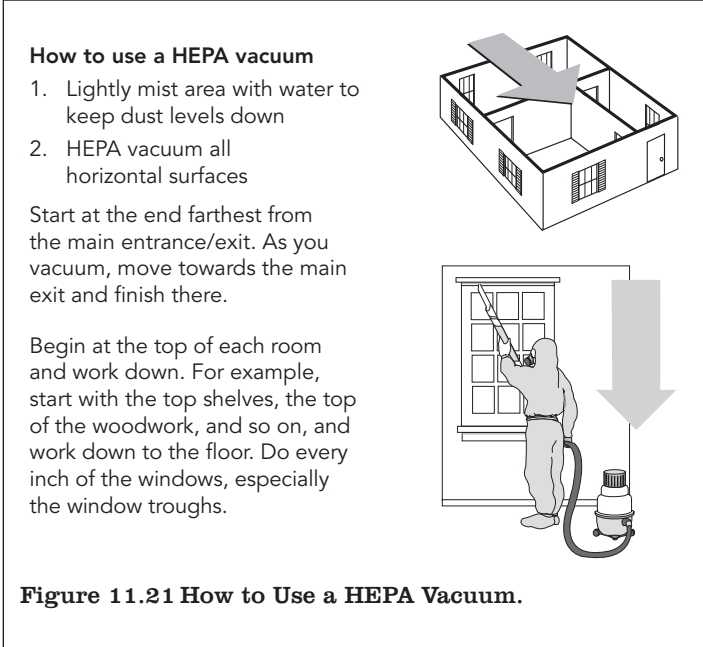

if possible. A sponge mop is likely to just push the dirt in front of it. A final cosmetic rinse is recommended using clean water.

- ◆ Clean until surface dust is no longer visible. After cleaning a window sill or a floor, rinse with clean water using a new sponge or cloth.
- ◆ To make a cleaning solution, mix with water according to the manufacturer's instructions for recommended concentrations. When using the cleaner, wear gloves and eye protection gear. Follow all manufacturer's instructions and precautions.
- ◆ Whenever possible, clean floors and pads underneath rugs and carpets.
- ◆ For dust removal projects in multi-family housing, a truck-mounted vacuum unit with a HEPA filter exhaust is preferable. Since the exhaust stream is located outside the dwelling it is not likely to disturb dust inside the dwelling.
- ◆ In a controlled environment capable of capturing any dust released by the procedure, remove and dispose of vacuum cleaner bags and filters offsite, according to the manufacturer's instructions. If the filters and/or bags need to be changed onsite in the middle of the job, take the vacuum unit outside the house if practicable. (see Figure 11.22).
  - If filters and/or bags must be replaced outside the building, but still on the property:
    - ◆ place the vacuum on a sheet of plastic,
    - ◆ replace the filters and/or bags,
    - ◆ wet clean the outside of the vacuum,
    - ◆ vacuum the plastic,
    - ◆ pull up the plastic,
    - ◆ vacuum the immediate area, and
    - ◆ dispose of the plastic.
  - If filters and/or bags must be replaced inside the building:
    - ◆ place the vacuum on a sheet of plastic,
    - ◆ replace the filters and/or bags,
    - ◆ wet clean the outside of the vacuum,
    - ◆ vacuum the plastic,
    - ◆ pull up the plastic,
    - ◆ vacuum and wet clean the immediate floor area, and
    - ◆ dispose of the plastic.



a) Remove the HEPA Vacuum Filters and Disassemble the Vacuum



b) Disconnect Vacuum Bag From Hose Inlet



c) Remove Bag with a Plastic Sheet Underneath



d) Tape Vacuum Bag Closed and Put Inside Plastic Trash Bag



e) Wash/Replace Coarse Prefilters if Necessary



f) Remove & Replace HEPA Filter Assembly.

**Figure 11.22** Changing HEPA vacuum filter.

## 2. Removal or Cleaning of Carpets

Carpeting and area rugs (all referred to here as carpets) can be major traps and reservoirs of leaded dust. Dust embedded in the fibers of carpets and rugs is not easily removed by cleaning.

The two methods of cleaning carpets that are generally available for residential settings are dry vacuuming and hot water extraction vacuuming (which can deliver detergents as well as heated water). Based on limited research, it appears that dry vacuuming has greater efficiency in removing embedded dust particles from carpets than hot water extraction with detergents (Lewis, 2002; Brown, 1982; CH2MHILL, 1991). Wet methods may be a useful supplement to dry vacuuming, especially if the dust is oily, as perhaps from kitchen aerosols.

The fundamental difficulty in cleaning carpets with deeply embedded dust lead is that (1) it is often difficult to remove a high percentage of the deep dust, yet; (2) unless most of the deep dust is removed, periodic vacuuming is likely to draw contaminated dust to the surface, where it is available for exposure to young children. Research indicates that dust lead hazards can be removed from most carpets by sustained vacuuming. The cost of removal from some carpets may exceed the cost of replacement (Ewers, 1994; Roberts, 2004; Roberts, 1999).

**Deciding whether to clean or dispose of carpets.** The first step in carpet dust removal is to decide if the carpet is going to be cleaned onsite, removed for disposal, or removed for

professional offsite cleaning. It may be preferable to dispose of carpets that are in poor condition or those known to be highly contaminated with lead. In fact it may be more costly to clean a lead-contaminated carpet or rug than to replace it.

Research has found that the following factors are associated with difficulty of dust removal from carpets and rugs:

- ◆ **The height and density of the pile.** Shag rugs are most difficult because the longer fibers retain dust particles (Wang, 1995; EPA, 1997c). High density, plush carpets are more difficult than low density, low pile carpets (Lewis, 2002).
- ◆ **Wear.** Worn carpeting may have more tangled fibers that make it difficult for dislodged dust particles to travel to the vacuum nozzle (Lewis, 2002). New rugs that have been recently soiled are easier to clean.
- ◆ **High dust lead loading.** Very high dust lead loadings are associated with lower collection efficiency (Wang, 1995; EPA, 1997c).
- ◆ **Duration of contamination.** The longer the duration of contamination, the more likely the dust particles are deeply embedded.
- ◆ **Low relative humidity.** Low humidity may intensify the electrostatic field between the dust particle and the fiber, making it more difficult to dislodge the particle (EPA, 1997c; Wang, 1995).

**Removal of carpets.** When a carpet or rug is going to be removed from a dwelling for either disposal, or offsite cleaning, the following procedure is recommended to minimize the exposure of workers and residents to leaded dust:

Mist the entire surface of the carpet to keep dust from spreading. Carefully roll up the carpet along with any padding. Wrap the carpet in a sheet of plastic, seal it with tape, and remove it from the dwelling.

If the padding is not going to be removed, clean it using the lead hazard control procedures for cleaning an area rug (see below). Note that the cost of replacing padding is often less than the cost of cleaning it.

Removal of a wall-to-wall carpet may generate significant amounts of airborne lead-contaminated dust, even more than removal of a area rug. Worksite preparation should be similar to a high dust job (see Chapter 8), although, of course, protective sheeting should not be placed on the carpet that is being removed. Furniture that cannot be moved from the room should be covered with impermeable protective sheeting. Removal of an area rug generates less dust if done according to the guidance in the previous paragraph, so it can be handled as a low dust job. Always vacuum the floor after removing the carpet so leaded dust is not tracked to other parts of the dwelling. (The floors may be wet washed after vacuuming if they are made of a material that will not be damaged by large amounts of water on them; they should be vacuumed again after they are dry.)

**Selecting a vacuum.** Vacuum cleaners used for cleaning up dust as a lead hazard control measure must be high efficiency particulate air (HEPA) vacuums if the work is covered by OSHA's Lead in Construction rule, EPA's RRP Rule, or HUD's LSHR. (See Appendix 6, and, in particular, 29 CFR 1926.62(h)(4), 40 CFR 745.85(b)(2)(A) and (B), and 24 CFR 35.145 and 150(b), respectively.)

HEPA vacuums differ from conventional vacuums in that they contain high-efficiency filters that are capable of trapping extremely small, micron-sized particles. These filters can remove particles of 0.3 microns or greater from air at 99.97 percent efficiency or greater. (A micron is 1 millionth of a meter, or about 0.00004 of an inch.)

(Some vacuums are equipped with an ultra-low penetration air (ULPA) filter that is capable of filtering out particles of 0.13 microns or greater at 99.9995 percent efficiency. However, these ULPA filters are slightly more expensive, and may be less available than HEPA filters.)

The characteristics of a vacuum that are associated with effectiveness of cleaning carpets are:

- ◆ **Particle lifting velocity.** This appears to be a function of the design of the nozzle as well as the suction (static pressure in the nozzle). High suction alone does not predict efficient dust lead recovery. Vacuum velocity may be more important with shag carpets than with other types of pile. (Wang, 1995; Lewis, 2002; EPA, 1997c).
- ◆ **An effective agitator bar, or beater bar.** A power driven agitator helps dislodge dust particles and can significantly increase dust collection efficiency (Roberts, 1991; CMHC, 1992; Ewers, 1994; Lewis, 2002; EPA, 1997c; CH2MHILL, 1991).
- ◆ **Filters and/or bags that capture the dust particles.** HEPA filters are preferred from a technical perspective, in addition to being required by regulations in most cases (see above), because they are likely to catch very small particles that may include allergens as well as lead. However, recent research indicates that very little dust escapes through the exhaust of good-quality non-HEPA vacuums (EPA, 1995c; Rich, 2002; Yiin, 2002; California Department of Health Services, 2004). Also, some manufacturers of conventional vacuums offer filtration systems that capture smaller particles than do traditional systems. Therefore, if a HEPA vacuum is not required by regulation and is not available, a good-quality non-HEPA vacuum can be used effectively, especially if it is fitted with a "HEPA-type" or "Allergy" filter bag (EPA, 2000a).
- ◆ **Durability.** Removal of deep dust by vacuuming may take hours, depending on the size of the carpet and its condition. Continual, weekly vacuuming is advised to maintain a nonhazardous surface. Therefore, it is important to have a vacuum that will withstand frequent use and continue to be effective in dust collection.

One study concluded that a vacuum to be used for deep dust removal "should be a high quality, durable, traditional upright (with beater bar), two motor upright (with beater bar), or two motor canister (with powered head)" and that a HEPA filter is advisable (Lewis, 2002). Another researcher has found that a vacuum fitted with a dirt sensor is very useful. The sensor measures the amount of dust being picked up and shows when no more dust or dirt is being collected (Roberts, 1999; Roberts, 2004).

**Duration of vacuuming.** The vacuuming time required to remove enough deep dust from old carpets to assure that the surface lead loading will be reduced varies with the factors described above under "Deciding whether to clean or dispose of carpets." Reported times have varied from 2 to 85 minutes per square meter (10 sq. ft.) (Roberts, 2002). Intensive vacuuming is necessary to remove embedded dust from old carpets (see Table 11.5).

**Table 11.5 Rug Cleaning Steps and Approximate Time Per 10 Square Feet.**

Step	Description	Time/10 ft <sup>2</sup>
1	HEPA vacuum pile side of rug with beater bar at a rate no faster than 1 minute for every 10 square feet.	60 seconds
2	Fold rug in half and HEPA vacuum bottom of rug without beater bar at a rate no faster than 1 minute per 10 square feet for traditional rugs, or normal speed for manufactured carpeting with plastic backing.	60 seconds for traditional rugs, or Approximately 10-30 seconds for manufactured carpeting with plastic backing.
3	HEPA vacuum bare floor and any padding (no rate restriction or beater bar).	Approximately 10–60 seconds
4	Fold other half of rug over and repeat steps 2 and 3 (no rate restriction and no beater bar).	Approximately 10–140 seconds
5	Fold rug back over so it is in its original position.	Approximately 10–30 seconds
6	HEPA vacuum top side of rug a final time with the beater bar. The rate is no faster than 2 minutes per 10 square feet.	120 seconds
	<b>Total Approximate Time</b>	<b>4.0–8.0 minutes</b>

**Cleaning area rugs.** If cleaning of area rugs is done onsite, the following steps are recommended:

- ◆ First, vacuum the pile side (the top side) with a vacuum equipped with a beater bar, or agitator attachment, on the vacuum head at a rate *no faster than* 1 minute for every 10 square feet.
- ◆ Fold the rug in half, exposing the backing of half of the rug. The backing of the rug should be vacuumed without using the beater bar attachment (City of Toronto, 1990) at a rate of 1 minute per 10 square feet.
- ◆ Vacuum the exposed pad under the rug, if present, at normal speed and fold back over the rug.
- ◆ Vacuum the exposed floor beneath the rug at normal speed, and unfold the pad and rug.
- ◆ Fold the rug in half again, exposing the backing of the other half of the carpet, and repeat the vacuuming of the bottom of the rug, the pad, and the floor underneath.
- ◆ Unfold the pad and rug.
- ◆ Vacuum the pile side of the rug again using the beater bar attachment. Vacuum at a rate no faster than 2 minutes per 10 square feet.

Consideration should be given to a final cleaning step consisting of a steam cleaning of the pile side of the rug. Steam cleaning can remove additional, but limited, amounts of lead from

rugs (CH2MHILL, 1991). This cleaning can be done by the contractor or owner using commercially available equipment. For multi-family buildings consideration should be given to the use of truck-mounted cleaning equipment since it may be significantly more powerful than typical rental equipment for residential use.

#### **Cleaning wall-to-wall carpeting.**

For cleaning wall-to-wall carpeting (see Figure 11.23), the following procedure is recommended:

Vacuum carpeting with a vacuum equipped with a beater bar or agitator attachment on the vacuum head. The beater bar helps to dislodge embedded dust. The total vacuuming time recommended is at least 4 minutes per 10 square feet of carpeting (Ewers et al., 1994), divided into two segments of at least 2 minutes for each 10 square feet. The two vacuuming segments are performed in perpendicular directions. For example, the first segment may be done in an east-west direction, while the second is done in a north-south direction.

The provisions regarding steam cleaning and suitability of general all-purpose household cleaners discussed in Section V.B.1, above, apply to wall-to-wall carpeting.

### **3. Cleaning Upholstered Furniture**

The first step in dealing with upholstered furnishings is to determine if the item is going to be discarded or cleaned. It may be preferable to dispose of items that are in poor condition or known to be highly contaminated with lead.

The recommended dust removal procedure for upholstered furniture is vacuuming. Upholstery surfaces should be vacuumed with three to five passes over each surface at a total rate of 2 minutes per 10 square feet. Steam cleaning, and other wet cleaning procedures are generally not recommended because they may damage fabrics. However, newer steam cleaners have a water extraction feature to prevent water damage to fabric. If wet cleaning is desired, test a small section of the fabric for color fastness before cleaning the entire surface.

Cloth throw covers, slipcovers, or fitted vinyl covers should be provided for all cleaned, upholstered items. This is particularly important for items at the end of their useful lives that would not hold up well under an aggressive vacuuming. A cloth cover material that can be easily removed and washed should be selected.

### **4. Forced Air Systems and Drop Ceilings**

If the ceilings or forced air systems contain leaded dust, they may present a hazard to maintenance or renovation workers who access them (City of Toronto, 1990).



**Figure 11.23 Carpet with debris and after cleaning.**

Where possible, return and supply air vent registers that can be easily removed should be taken out, vacuumed, and wet cleaned (see Figure 11.24 and 11.25). If the vent registers are sealed to the wall or floor with paint, the edges should be misted and scored to help free the vent register with a minimum of leaded dust generation.

Air vent registers that cannot be easily removed should be vacuumed and wet cleaned in place. The horizontal surfaces in the ductwork that can be easily reached with the vacuum attachment should be cleaned. Water should not be poured down the air duct to clean the vent register; wiping with a damp sponge or mop is adequate. Take care not to cut hands on sharp metal in the vent.

Clean or replace the air filters on heating units and air conditioners with new filters at the time of dust removal. Used filters should be placed in plastic bags and sealed prior to disposal to minimize the potential spread of leaded dust.



Figure 11.24 Air vent before and after cleaning.



a. Vacuum and remove register covers;

b. Vacuum Accessible Parts of Duct Opening

c. Wet wash register covers and replace

Figure 11.25 Clean Air Vent Registers

Leaded dust in non-forced air systems and drop ceilings is not considered a hazard to residents unless major disturbances of the ducts or ceilings are planned, such as repairs or relocations of ducts. When major disturbances of any type of duct or ceiling work are anticipated, cleaning will probably be warranted. This includes instances when forced air systems have the direction of airflow reversed during maintenance.

### 5. Resident Protection

To facilitate dust removal work and provide protection for occupants, only workers and their supervisors should be in the work area during the dust removal process. This will also help ensure that work can be completed in 1 day. Worksite preparation for low dust jobs is usually adequate for dust removal unless lead-contaminated wall-to-wall carpets are being removed.

In addition, disposable or easily cleaned walk-off mats (door mats) should be placed at entryways to control the tracking of leaded dust into the dwelling (see Figure 11.26).



**FIGURE 11.26** Walk-Off Mats

### C. Follow-up to Dust Removal

If the clearance area may have had high lead levels before the work and/or has rough horizontal surfaces that may make clearance difficult, the owner or contractor may consider using a pre-clearance screen before calling the clearance examiner. See Section II.J, above, for additional information.

Lead-based paint inspectors, risk assessors, or sampling technicians performing clearance examinations should check to see that all visible dust, debris and residue have been removed from the dwelling before collecting dust samples. (See Chapter 15 for information on clearance.) The clearance dust sampling results will provide a means of checking that lead levels have been reduced by the dust removal work, and will serve as a baseline for comparison to future test results.

In addition to the standard EPA and HUD requirement to perform clearance on carpeted as well as uncarpeted floors, if area rugs have been cleaned as a lead hazard control measure, they, too, should be cleared in order to demonstrate the effectiveness of the cleaning.

Since it has been shown that lead-contaminated dust can re-accumulate on household surfaces following lead-based paint abatement and dust removal alone (Lanphear, 2000; Farfel and Chisolm, 1987b; Jacobs, 1992; Clark, 1993), ongoing lead-safe maintenance and professional reevaluation of the dwelling, resident education, and continued cleaning are important elements of a dust removal plan.

Educational materials prepared by State or local government agencies, or lead poisoning prevention organizations should explain the need for periodic wet cleaning of household surfaces, with particular attention to dust traps and reservoirs, and the importance of the disposal of air conditioning and heating unit filters that are routinely cleaned or replaced by the residents. Some owners and municipalities provide cleaning kits to residents to encourage and support their ongoing dust removal efforts. (See Chapter 2 and Section I of this chapter for information on resident education.)

## VI. Soil Interim Controls

### How To Do It

1. **Plan Soil Interim Controls.**
  - ◆ Select appropriate soil interim controls, which may include soil alterations, soil surface coverings, land use controls, reduction of soil tracking, or drainage and dust controls.
  - ◆ Prepare a site plan of the yard, showing the soil lead hazard controls. Retain plans for use in ongoing monitoring.
2. **Contain and dampen dust.** Prepare worksite in accordance with guidance in Chapter 8. Use water to contain dust during the work, and clean play equipment.
3. **Establish soil alteration.** Impermanent surface coverings include grass (as seed or sod), other ground covers (e.g., ivy), artificial turf, bark, mulch, and gravel. If the area to be controlled is heavily traveled, impermanent surface coverings, such as grass, are not appropriate.
4. **Put soil surface coverings in place.**
  - ◆ If grass is selected, consult with the local agriculture extension service, or a reputable local nursery, to determine what grasses are appropriate for the locale, soil type, and sun/shade characteristics. Properly prepare the soil prior to seeding or sodding.
  - ◆ If mulch or bark is selected, apply the covering 4-6 inches deep (3 inches is more appropriate for gravel). New bark, gravel, or other materials should not contain more than 200 µg/g of lead, if possible, and never more than 400 µg/g.
  - ◆ If live ground covers (including grass) are selected, it is imperative that they are properly watered during the first 3 months and adequately maintained thereafter. Automatic sprinkler systems are appropriate for large properties.
  - ◆ If the soil is in a public recreation area, comply with Consumer Product Safety Commission standards on acceptable surface coverings in play areas.
5. **Install land use controls.** Land use controls include fencing, warning signs, changes in administrative practices, creation of alternative play areas (such as decking), and thorny bushes.
6. **Drainage and dust controls.** Control water erosion by proper grading to pitch the slope away from the building and installing drainage channels (drainage channels may need to be fenced or covered if they are accessible). Control wind erosion by periodic watering, windbreaks, or foot traffic controls.
7. **Reduce dust tracking.** Provide walk-off doormats at all entryways to reduce the tracking of contaminated dust and soil into the dwelling.
8. **Perform ongoing monitoring and maintenance.** Perform ongoing monitoring and maintenance of soil coverings and land use controls. If ongoing monitoring shows that bare soil remains, or reappears within 12 months of an interim soil control, the interim controls are not effective. Soil abatement should be conducted (see Chapter 12), unless other interim controls can be shown to be effective for the specific site.
9. **Reevaluation.** If required by regulation or the property owner or manager's preference, conduct reevaluations every two years in accordance with guidance in Section VII of Chapter 5.

### A. Definition of Soil Lead Hazards

A soil lead hazard in residential property is bare soil that contains total lead equal to or exceeding:

- ◆ 400 parts per million (or  $\mu\text{g/g}$ ) for play areas frequented by children under 6 years of age, or
- ◆ 1,200 parts per million (or  $\mu\text{g/g}$ ) for other parts of the yard including the dripline/foundation area in non-play areas.

These values are from the federal lead hazard standards rule (at 40 CFR 745.65(c)). State and local standards may vary; if lower, they apply to the housing.

EPA does not provide for a *de minimis* area of bare soil outside the play area that can exceed the 1,200  $\mu\text{g/g}$  standard, such as the 9 square feet per property that HUD had incorporated into its Lead Safe Housing Rule (24 CFR 35.1320(b)(2)(ii)(B)) issued 1½ years before the EPA issued the lead hazard standards rule. EPA noted that it had no analysis or data that relate the amount of bare soil to risk, and the incremental cost of including soil testing in a risk assessment is small. As noted in Chapter 5 of these *Guidelines*,

“However, EPA highly recommends using the HUD Guidelines for risk assessment.... This would avoid declaring very small amounts of soil to be a hazard in the non-play areas of the yard. This would also help target resources by eliminating the need to evaluate soil or respond to contamination or hazards for properties where there is only a small amount of bare soil.”

Once soil sampling establishes that a yard has soil lead hazards, it can be useful to create a map of soil lead concentrations in the yard, such as by using an XRF analyzer that is capable of direct measurement of soil lead concentrations (EPA, 2001a), or by soil sampling and analysis (see Chapter 5, Sections II.C and IV, respectively). This information can be useful for developing a customized interim control plan for the particular yard.

### B. Temporary and Permanent Soil Treatments

Interim measures for controlling soil lead hazards include surface coverings with grass, gravel, mulch, wood chips, or similar materials, or land use controls, such as fences, thorny bushes, or decks, for preventing contact with the contaminated soil. These interim controls are designed to temporarily reduce exposure. How long they remain effective depends on many factors, including the durability and maintenance of the cover, amount or degree of foot traffic, and climate.

Soil abatement measures are described in Chapter 12, Section V. If the control measure consists of replacing soil that is a soil-lead hazard (see Section A, above) with soil of acceptable lead levels, or includes installing a permanent cover, such as asphalt or concrete, the method is classified as abatement.

### C. Types of Interim Control Measures for Soil

Five types of measures may be used as part of an interim control plan for soil. They are:

- ◆ Measures that alter the contaminated soil.
- ◆ Measures that alter the surface cover.
- ◆ Land use controls.

- ◆ Measures that reduce soil tracking
- ◆ Measures to reduce offsite drainage or dispersal of the contaminated soil.

Each of these activities should be carried out in a manner that prevents further dispersal of the contamination and prevents the area undergoing the interim control treatment from being contaminated in the process. Work practices for soil interim controls are similar to those for soil abatement and are described more fully in Chapter 12, Section V.

## 1. Soil Alteration

Interim controls usually involve some alteration of the soil. Examples include surface cultivation, additives, or rototilling clean soil into existing soil to assist in establishing ground cover (e.g. grass, ivy). Grading of the soil is sometimes needed to assure proper drainage. Typically surface alteration is not effective enough to be used as the sole interim control measure. Tilling and mixing the soil to a depth of at least 8 inches may be effective. The addition of clean soils and compost can be used to reduce the lead concentration of vegetable garden soils that are only slightly above the recommended maximum 400 ppm lead concentration, however, for highly contaminated garden soils the contaminated soil should be removed and replaced with clean soil or the garden should be relocated.

## 2. Soil Surface Cover

The most common form of soil interim control is surface covering that creates a barrier between leaded soil and children. Typical materials include bark mulch, pea gravel, crushed stone, grass seeding, sod, other live ground covers (e.g., juniper, shrubs, ivies), and paving stones. Except with installations of grass seed or sod, a water permeable landscape fabric should always be used to create a barrier between the soil and the installed material. Landscape fabric controls for weeds, creates a clear barrier to leaded soil, and visually signals when the installed material needs to be replenished.

The choice of a covering for a particular area depends on the climate, expected use, planned maintenance, and aesthetic preferences. For aesthetic as well as practical reasons, a property owner may choose to improve the surface cover over an entire soil area even though only a portion is bare.

The success of grass and other live ground covers is dependent on proper planting, adequate water and sunlight, regular maintenance, and most importantly, the ability to control the use of the area. In high traffic areas use of grass as an interim control is unlikely to succeed. Where access to an area can be controlled, or where use is expected to be limited, grass and other live ground covers can be successful interim controls. Some ground covers, such as juniper bushes, can also effectively limit traffic through an area. Shade tolerant ground covers such as ivies are better suited than grass for areas that receive little sunlight.

Before using grass or live ground covers as an interim control measure, a property owner should consult with a lawn care professional about soil preparation, appropriate grasses and plants to use, and future maintenance requirements. The county cooperative extension service or a reputable local nursery may be contacted for advice on types of grass or other ground cover to be used in specific geographic areas and for specific soil types, slope, and sunlight conditions. Table 11.6 offers a brief summary of grass types and their suggested uses.

The local office of the U.S. Department of Agriculture's Natural Resources Conservation Service (<http://www.nrcs.usda.gov/wps/portal/nrcs/main/national/home>) may also be able to provide advice about soil conditions in a specific geographic area. An owner of a large property may consider installing a sprinkler system to improve the maintenance effort. In any event some type of hose and sprinkler system should be made available.

An owner should consider whether sod or seeding is more appropriate when planting grass. Both grass seed and sod require restrictions on foot traffic until root systems and stems become established. Newly laid sod requires at least 2 weeks, while grass seed requires 1 to 2 months (Lane Publishing, 1989; Maryland Cooperative Extension, 1994). Sod can be laid during most of the year (as long as the ground is not frozen) and requires less initial care. However, sod is more expensive than seeding and is less likely to develop the deep root systems that will allow the grass to withstand regular wear and tear. It is best to lay sod during the growing season.

At least 3–4 inches of bark, mulch, wood chips or gravel are recommended to serve as a temporary ground covering (see Figure 11.18). If the covering is more than 3 inches thick, water will not reach plantings that may be in the area. Four inches is recommended for play areas. This level of material can be achieved by constructing a raised bed framed with 2" x 6" ACQ (alkaline copper quaternary) pressure-treated lumber. ACQ-treated lumber (or newer composite/non-wood materials) contains no EPA-listed hazardous compounds, whereas chemicals used in traditional pressure-treated lumber include compounds of, in addition to, copper, chromium and arsenic (commonly referred to as CCA-treated lumber), which may leach into the environment. Rock or other edging material may be used instead of lumber, depending on site specific conditions.

Do not use mulch made from recycled building components unless it has been tested and found to contain less than 400 µg/g of lead. EPA requires that replacement soil used in soil abatement contain less than 400 µg/g of lead. If possible, replacement bark, mulch, wood chips, and added soil should contain no more than 200 µg/g of lead, in order to provide a further safety factor.

Bark or other suitable soft material should be used as surface cover for contaminated soil near play equipment. This will offer a degree of protection from injuries that may result from falling. Consumer Product and Safety Commission regulations dealing with acceptable surface coverings in play areas may apply to public areas (CPSC, 1991). Artificial turf can also be used, but may cause drainage problems if it is not permeable.

Rubber cushioning specifically designed for playgrounds can also be used to cover contaminated, bare soil in play areas.

### 3. Raised Beds and Other Landscaping Options

The installation of raised beds can be an effective control measure in areas with high soil lead levels where grass would not be expected to grow well. They are often well suited for use in the drip zones of homes (i.e., the area extending approximately 3 ft. from the foundation). The beds can be created using 2" x 6" ACQ pressure-treated lumber, using landscape fabric to cover the ground followed by the application of top soil and mulch if the beds will be planted. If the beds are not planted, mulch, woodchips, or gravel can be placed directly over the landscape fabric.

A cost-effective approach to treat bare foot paths is to place stone or concrete stepping stones along the pathway and cover surrounding bare soils with a layer of gravel or mulch.

An option for play areas and picnic areas with contaminated bare soils is to create raised wooden platforms using ACQ pressure-treated lumber. This may be especially appropriate for small yards where relocation of such activities within the yard area is not possible.

#### 4. Land Use Controls

Altering the use pattern of the yard is another common way to control human exposure to bare, contaminated soil. Measures include: fencing, to create a barrier to contaminated soil; planting thorny or dense bushes (see Figure 11.27) to discourage access; decks with lattice added below to restrict access to soil under the deck; relocating play areas to move a play area away from old painted structures, such as a fence or shed, and away from areas with high soil lead levels; warning signs; and educational efforts.

Preventing access to the bare, contaminated soil by fencing is most effective if other entrances and exits to the housing units can be maintained for use by residents, guests, commercial vehicles, and emergency vehicles (see Figure 11.28). Fencing may also be used to reduce exposure during a delay in the implementation of other interim control measures or soil abatement.

Educational efforts directed towards decreasing use of bare, lead-contaminated areas; avoiding eating or drinking in these areas; and frequent washing of hands may serve to reduce ingestion of the contaminated soil. The decision on whether to plant grass or erect barriers should be site-specific. Consideration should be given to the availability of alternative play areas, the location of contaminated soil with respect to entrances or exits, the likelihood that leaded dust may be tracked onto sidewalks or directly into the housing unit, the degree of supervision available, and local preferences.



**FIGURE 11.27** Thorny Bushes as a Land Use Control



**FIGURE 11.28** Using Fencing as an Interim Control. a) For Bare Soil. b) For other soil.

**Table 11.6 Grasses and Their Appropriate Applications.**

<b>Grasses That Grow From Seeds</b>	<b>Texture</b>	<b>Climate</b>	<b>Durability</b>
Bahia grass	Coarse	Warm	Excellent
Colonial Bent grass	Fine	Cool	—
Creeping Bent grass	Fine	Cool	—
Common Bermuda grass	Medium to Fine	Warm	Excellent
Kentucky Bluegrass	Fine	Cool	—
Rough Stalk Bluegrass	Fine	Cool	—
Centipede grass	Medium to Fine	Warm	—
Dichondra	Coarse	Warm	—
Chewings Fescue	Fine	Cool	Poor
Creeping Red Fescue	Fine	Cool	Poor
Hard Fescue	Fine	Cool	—
Tall Fescue	Coarse	Cool	Moderate to Excellent
Annual Ryegrass	Coarse	Cool	—
Perennial Ryegrass	Fine	Cool	Excellent
<b>Grasses That Grow From Sod</b>	<b>Texture</b>	<b>Climate</b>	<b>Durability</b>
Bahia grass	Coarse	Warm	Excellent
Hybrid Bermuda grass	Fine	Warm	Excellent
Kentucky Bluegrass	Fine	Cool	—
Centipede grass	Medium to Fine	Warm	Poor
Dichondra	Coarse	Warm	—
Tall Fescue	Coarse	Cool	—
Seashore Paspalum	Medium	Warm	—
Perennial Ryegrass	Fine	Cool	Excellent
St. Augustine grass	Coarse	Warm	—
Zoysia grass	Fine	Warm	Excellent

## 5. Reduction of Soil Tracking into Dwellings

Doormats can be used to minimize the entry of soil lead into the house. Doormats should be placed on the exterior and immediate interior of the entry doors. Mats should be cleaned by machine washing, or other wet methods, not by beating or sweeping. (See Section V of this chapter for further information.)

Removing shoes at the doorway also greatly minimizes the amount of leaded soil and dust tracked into the house.

## 6. Drainage and Dust Controls

Drainage controls may involve directing water flow away from the contaminated areas by alterations in adjacent grades and/or installation of drainage channels. Drainage channels that receive runoff from bare, contaminated soil areas may need to be fenced to reduce access. Dust generation can be reduced by periodic watering, the creation of windbreaks, or foot-traffic controls.

### D. Making a Plan

It is recommended that a site plan of the yard be drawn to aid in planning soil lead hazard controls, and to serve as a documentation of the type and location of controls for future reference. The hazard control plan should be based on the nature and extent of hazards, yard use, topography, cost, future maintenance considerations, and property owner preference. In most situations, there is a range of acceptable treatments. Decisions are usually site specific. Working with a qualified landscaping professional to develop standards, details, and bid documents is recommended.

Often owners will be partial to certain types of soil lead hazard treatments (e.g. grass, gravel, mulch, fencing). Owners' preferences need to be balanced with lead levels, yard uses, and budget when selecting treatment methods. For example, an owner may want a lawn but grass treatments can be difficult to sustain in an urban yard due to excessive shade, compacted soil, or lack of watering by an owner. Property owner involvement in decision making will help motivate owners to maintain lead hazard control measures over time. Some important questions to ask during planning are:

- ◆ How highly contaminated is the soil?
- ◆ How is the yard used? Play, gardening, pets, picnicking, parking?
- ◆ Does the yard have primarily sunny or shady conditions?
- ◆ Are the plants selected appropriate to the yard conditions and region of the country?
- ◆ What is the budget for the project?
- ◆ Who will maintain the yard improvements after the work is completed?

**E. Guidance on Specifications for Interim Controls of Soil Lead Hazards**

Appendix 7.4 includes suggested language that may be helpful in drafting specifications for methods and products used in interim controls of soil lead hazards is provided below, and notes to specification developers.

Specification developers may adapt the specification language as needed to fit each particular site and each plan or design. Landscape contractors may be unfamiliar with the issue of lead in soil. Their standard practices may not be in line with lead-safe treatment methods. It is advisable to work closely with contractors on their first few lead-safe jobs to ensure that they are clear on how to properly implement interim controls. If abatement of soil lead hazards is planned, specifications should be written by a person certified in accordance with regulations of EPA or an EPA-authorized state, tribe or territory.

**F. Monitoring and Maintaining Soil Interim Controls**

If grass or sod is planted, or if bark, gravel, or other similar covering is used, it should be monitored visually. The monitoring should occur frequently immediately after installation and can be reduced thereafter. If ongoing monitoring shows that bare soil remains or reappears within 12 months of an interim soil control, the selected interim control is not effective. Soil abatement should be conducted (see Chapter 12), unless other interim controls can be shown to be effective for the specific site.

# References

Banov, 1978. Banov, A., *Paints and Coatings Handbook*, Structures Publishing Company, Farmington, Michigan.

Brown, 1982. Brown, E, *Fundamentals of Carpet Maintenance: An Introduction Carpet Cleaning Technology*, Leeds, W. Yorkshire: P.A. Brown & Assoc.

California Department of Health Services, 2004. Public Health Institute for California Department of Health Services, Childhood Lead Poisoning Prevention Branch and Environmental Health Laboratory Branch, "Evaluation of Household Vacuum Cleaners in the Removal of Settled Lead Dust from Hard Surface Floors," Final Report to U.S. Department of Housing and Urban Development, 2004.

Cassens and Feist, 1991. Cassens, D.L., and W.C. Feist, *Exterior Wood in the South [also Northeast, Northwest, etc.], Selection, Applications and Finishes*, Technical Report FPL-GTR-69, U.S. Department of Agriculture, Forest Products Laboratory, Madison, Wisconsin, May 1991.

CH2MHILL, 1991. CH2MHILL, *Final House Dust Remediation Report for the Bunker Hill CERCLA Site Population Area RI/FS*, Boise, ID, Idaho Department of Health and Welfare, editor and sponsor. BHPA-HDR-F-RO-052091. See Summary And Assessment Of Published Information On Determining Lead Exposures And Mitigating Lead Hazards Associated With Dust And Soil In Residential Carpets, Furniture, And Forced Air Ducts, EPA 747-S-97-001 available at [www.epa.gov/lead/pubs/ls\\_final.pdf](http://www.epa.gov/lead/pubs/ls_final.pdf).

City of Toronto, 1990. City of Toronto Department of Public Health in conjunction with Ontario Ministry of the Environment, *Lead Reduction Program House Dust Cleaning: Final Report*, Concord Scientific Corporation and Gore & Storrie Limited in association with South Riverdale Community Health Centre, Toronto, Montreal, Canada.

Clark, 1993. Clark, C.S., R.L. Bornschein, J. Grote, W. Menrath, W. Pan, S. Roda, and P. Succop. *Cincinnati Soil Lead Abatement Demonstration Project Final Report*, August 1993.

Clark, 2002. Clark, C.S., "Development of a Rapid On-Site Method for the Analysis of Dust Wipes Using Field Portable X-Ray Fluorescence," prepared for the U.S. Department of Housing and Urban Development, January 2002.

CMHC, 1992. Canada Mortgage and Housing Corporation, Saskatchewan Research Council Report, *Effectiveness of Cleanup Techniques for Leaded Paint Dust*, Saskatoon, Saskatchewan, Canada (also see Figley, 1994).

CPSC, 1991. Consumer Product Safety Commission, *Handbook for Public Playground Safety, Recommendations for Surfacing Materials*, Washington, DC, 1991. Updated 2008. [www.cpsc.gov/cpscpub/pubs/325.pdf](http://www.cpsc.gov/cpscpub/pubs/325.pdf)

EPA, 1992a. U.S. Environmental Protection Agency, *Training Course for Lead-Based Paint Abatement Project Supervisors*, Washington, DC.

EPA, 1995c. U.S. Environmental Protection Agency, *Lead-Based Paint Abatement and Repair and Maintenance Study in Baltimore: Pre-Intervention Findings*, EPA 747-R-95-012. [www.epa.gov/lead/pubs/r95-012.pdf](http://www.epa.gov/lead/pubs/r95-012.pdf)

EPA, 1997a. U.S. Environmental Protection Agency, *Laboratory Study of Lead-Cleaning Efficacy*, March 1997 (EPA 747-R-97-002). Accessed from [nepis.epa.gov](http://nepis.epa.gov) by searching for 747R97002.

EPA, 1997c. U.S. Environmental Protection Agency, *Summary and Assessment of Published Information on Determining Lead Exposures and Mitigating Lead Hazards Associated With Dust and Soil in Residential Carpets, Furniture and Forced Air Ducts*, December 1997 (EPA 747-S-97-001). Accessed from [nepis.epa.gov](http://nepis.epa.gov) by searching for 747S97001.

EPA, 1998. U.S. Environmental Protection Agency, *Lead-Cleaning Efficacy Follow-Up Study*, October 1998 (EPA 747-R-98-008).

EPA, 2000a. U.S. Environmental Protection Agency, *Basis for Educational Recommendations on Reducing Childhood Lead Exposure*, June 2000 (EPA 747-R-00-001). [www.epa.gov/lead/pubs/reduc\\_pb.pdf](http://www.epa.gov/lead/pubs/reduc_pb.pdf)

EPA, 2000x. U.S. Environmental Protection Agency, "Regulatory Status of Waste Generated by Contractors and Residents from Lead-Based Paint Activities Conducted in Households," Memorandum signed July 31, 2000. See [www.epa.gov/lead/pubs/fslbp.htm](http://www.epa.gov/lead/pubs/fslbp.htm). Accessed 5/3/2006; this site may be moved or deleted later.

EPA, 2001a. U.S. Environmental Protection Agency, *Lead safe Yards: Developing and Implementing a Monitoring, Assessment, and Outreach Program for Your Community*, EPA. National Risk Management Laboratory, Office of Research and Development, Cincinnati, Ohio, January 2001 (EPA/625/R-00/012). <http://www.epa.gov/region1/leadsafe/tool2.html>

EPA, 2001y. "Mold Remediation in Schools and Commercial Buildings", EPA 402-K-01-001, March 2001. Available in pdf at [www.epa.gov/mold/moldresources.html](http://www.epa.gov/mold/moldresources.html), and may be ordered from:

- ◆ EPA National Service Center for Environmental Publications (NSCEP) ([www.epa.gov/ncepihom/](http://www.epa.gov/ncepihom/)). Publication requests can also be mailed, called or faxed directly to: EPA National Center for Environmental Publications (NSCEP), P.O. Box 42419, Cincinnati, OH 42419, (800) 490-9198, (513) 489-8695 (fax); or
- ◆ IAQ INFO, P.O. Box 37133, Washington, DC 20013-7133, (800) 438-4318, (703) 356-4020, (fax) (703) 356-5386, [iaqinfo@aol.com](mailto:iaqinfo@aol.com).

EPA, 2002a. U.S. Environmental Protection Agency, "Questions & Answers About ETV Reports on Portable Technologies for Measuring Lead in Dust," December 2002.

EPA, 2002b. U.S. Environmental Protection Agency, The Environmental Technology Verification Program (ETV), Verification Statements EPA-VS-SCM-50, 51, 52, 53 and 54. Prepared by Oak Ridge National Laboratory, Oak Ridge, Tennessee, August 2002.

EPA, 2002c. U.S. Environmental Protection Agency, "A Brief Guide to Mold, Moisture, and Your Home," (EPA 402-K-02-003). Available at [www.epa.gov/mold/moldresources.html](http://www.epa.gov/mold/moldresources.html).

EPA, 2003w. U.S. Environmental Protection Agency, Criteria for Classification of Solid Waste Disposal Facilities and Practices and Criteria for Municipal Solid Waste Landfills: Disposal of Residential Lead-Based Paint Waste, Final Rule, Federal Register 68(117) 36487-36495: June 18, 2003. Accessed 10/10/2010 through <http://origin.www.gpoaccess.gov/fr>.

EPA, 2003x. "A Brief Guide to Mold, Moisture, and Your Home," EPA 402-K-02-003, 2003. Available in pdf format at [www.epa.gov/mold/moldresources.html](http://www.epa.gov/mold/moldresources.html), also see EPA 2001y.

Ewers, 1994. Ewers, L., S. Clark, W. Menrath, P. Succop, and R. Bornschein, "Cleanup of Lead in Household Carpet and Floor Dust," *Journal of the American Industrial Hygiene Association*, 55(7): 650-7.

Farfel and Chisolm, 1987a. Farfel, M., and J.J. Chisolm, Jr., "Comparison of Traditional and Alternative Residential Lead Paint Removal Methods," in *Proceedings of the 6th International Conference on Heavy Metals in the Environment (Volume II)*, eds. S.E. Lindberg and T.C. Hutchinson, New Orleans, Louisiana, September 1987, pp. 212–214.

Farfel and Chisolm, 1987b. Farfel, M., and J.J. Chisolm, Jr., *Reducing Hazards From the Abatement of Lead Paint: Part 1—Pilot Demonstration and Evaluation of Alternative Abatement Practices*, Baltimore Integrated Environmental Management Project Phase II Report, Regulatory Integration Division, Office of Policy Analysis, Office of Policy, Planning, and Evaluation, U.S. Environmental Protection Agency.

Figley, 1994. Figley, D., and Makohon, J., "Effectiveness of Clean-Up Techniques for Leaded Paint Dust," Saskatoon, Saskatchewan: Saskatchewan Research Council, revised report SRC I-4800-38-C-92 to Canada Mortgage and Housing Corporation (originally published in 1992).

Jacobs, 1992. Testimony of D.E. Jacobs at the Hearings Before the Subcommittee on Housing and Community Development of the Committee on Banking, Part 2, S/N 102–108, U.S. House of Representatives, April 2, 7, and 29, 1992, pp. E832–842.

Lane Publishing, 1989. *Sunset Lawns and Ground Covers*, Menlo Park, California.

Lanphear, 2000. Lanphear, B.P., Eberly, S., Howard, C.S., "Long-Term Effect of Dust Control on Blood Lead Concentrations. *Pediatrics*, 106: 48e-48. <http://pediatrics.aappublications.org/content/106/4/e48.full>

Lewis, 2002. Lewis, R.D., "The Removal of Lead-Contaminated House Dust from Carpets and Upholstery, Final Report," prepared for U.S. Department of Housing and Urban Development, Office of Healthy Homes and Lead Hazard Control, January 2002.

Lewis, 2006. Roger D. Lewis, Sridhar Condoor, Joe Batek, Kee Hean Ong, Denis Backer, David Sterling, Jeff Siria, John J. Chen, and Peter Ashley, "Removal of Lead Contaminated Dusts from Hard Surfaces," *Environ. Sci. Technol.*, 40, 590 -594, 2006. <http://pubs.acs.org/doi/abs/10.1021/es050803s>.

Maryland Cooperative Extension, 1994. Lawn Care Ruler, FS-637R.

Milar, 1982. Milar, C.R. and P. Mushak, "Contaminated House Dust: Hazard, Measurement and Decontamination," in *Lead Absorption in Children: Management, Clinical, and Environmental Aspects*, eds., J.J. Chisolm and D.M. O'Hara, Urban & Schwarzenberg, Baltimore/Munich, pp. 143–152.

NCHH, 2004. National Center for Healthy Housing, and University of Cincinnati Department of Environmental Health, *Evaluation of the HUD Lead-Based Paint Hazard Control Grant Program: Final Report*, prepared for the U.S. Department of Housing and Urban Development, Washington, DC, May 1, 2004.

Rich, 2002. Rich, David Q., G.G. Rhoads, L. Yiin, J. Zhang, Z. Bai, J.L. Adgate, P.J. Ashley and P.L. Liyo, "Comparison of Home Lead Dust Reduction Techniques on Hard Surfaces: The New Jersey Assessment of Cleaning Techniques Trial," *Environmental Health Perspectives*, 110(9): 889-893, September 2002. <http://www.ncbi.nlm.nih.gov/pmc/articles/PMC1240988/>; doi:10.1289/ehp.02110889

Roberts, 1991. Roberts, J.W., D.E. Camann, and T.M. Spittler, "Reducing Lead Exposure From Remodeling and Soil Track-In in Older Homes," in *Proceedings of the Annual Meeting of Air and Waste Management Association*, Paper No. 91–134.2, Vancouver, British Columbia, Canada.

- Roberts, 1999. Roberts, J.W., W.S. Clifford, G. Glass, and P.G. Hummer, "Reducing Dust, Lead and Dust Mites, Bacteria and Fungi in Carpets by Vacuuming," *Archives of Environmental Contamination and Toxicology*, 36: 477-484.
- Roberts, 2002. Roberts, J.W., Letter from John W. Roberts to Jackson L. Anderson, National Center for Healthy Housing, September 27, 2002.
- Roberts, 2004. Roberts, J.W., Glass, G, and Mickelson, L., "A Pilot Study of the Measurement and Control of Deep Dust, Surface Dust, and lead in 10 Old Carpets using the 3-Spot Test While Vacuuming," *Archives of Environmental Contamination and Toxicology*, 48: 16-23.
- Tohn, 2000. Tohn, E.R., S.L. Dixon, D. Rupp and C.S. Clark, "A Pilot Study Examining Changes in Dust Lead Loadings on Walls and Ceilings After Lead Hazard Control Interventions," *Environmental Health Perspectives*, 105(5): 453-456. <http://ehp03.niehs.nih.gov/article/info%3Adoi%2F10.1289%2Fehp.00108453>; doi:10.1289/ehp.00108453
- Tohn, 2003. Tohn, E.R., S.L. Dixon, W.A. Galke and C.S. Clark, "An Evaluation of One-Time Professional Cleaning in Homes With Lead-Based Paint Hazards," *Journal of Applied and Occupational Hygiene*, 18(2): 138-143.
- Wang, 1995. Wang, E., G.G. Rhoads, T. Wainman and P.J. Lioy, "Effects of Environmental and Carpet Variables on Vacuum Sampler Collection Efficiency," *Applied Occupational Environmental Hygiene*, 10(2): 111-119.
- Yiin, 2002. Yiin, Lih-Ming, F.F. Rhoads, D.Q. Rich, J. Zhang, Z. Bai, J.L. Adgate, P.J. Ashley and P.J. Lioy, "Comparison of Techniques to Reduce Residential Lead Dust on Carpet and Upholstery: The New Jersey Assessment of Cleaning Techniques Trial," *Environmental Health Perspectives*, 110(12): 1-5. <http://ehp03.niehs.nih.gov/article/ehp.action?articleURI=info%3Adoi%2F10.1289%2Fehp.021101233>



# CHAPTER 12: ABATEMENT

Step-by-Step Summary for Abatement .....	12-5
I. Principles of Lead-Based Paint Hazard Abatement .....	12-7
A. Longevity of Abatement .....	12-7
B. Prohibited Abatement Methods .....	12-9
C. Periodic Monitoring and Reevaluation .....	12-9
1. Recordkeeping .....	12-9
D. Types of Abatement .....	12-10
E. Encapsulation .....	12-10
F. Relationship to Renovation, Repainting, Remodeling, Rehabilitation, Weatherization, and Other Construction Work .....	12-10
Step-by-Step Summary for Building Component Replacement .....	12-13
II. Building Component Replacement .....	12-15
A. Worksite Preparation .....	12-15
1. Security .....	12-15
2. Waste Storage .....	12-15
B. General Procedures for Building Component Replacement .....	12-15
C. Removal and Replacement Procedures for Specific Components .....	12-17
1. Baseboards, Casings, and Other Trim .....	12-17
2. Windows .....	12-17
3. Interior and Exterior Doors .....	12-18
4. Kitchen and Bathroom Cabinets .....	12-19
5. Railings .....	12-19
6. Exterior Siding .....	12-19
7. Interior Walls .....	12-20
D. Transportation and Storage of Waste .....	12-20
Step-by-Step Summary for Enclosure Methods .....	12-21
III. Enclosure Methods .....	12-23
A. Definition .....	12-23
B. Longevity of Enclosures .....	12-23
1. Labeling of Enclosed Surfaces .....	12-23
2. Monitoring Enclosure Integrity .....	12-23
3. Unsound Substrates .....	12-24



C. Interior Surface Enclosure Materials .....	12-26
1. Wood Paneling .....	12-26
2. Laminated Products .....	12-26
3. Ridged Tile and Brick Veneers .....	12-26
4. Drywall and Fiberboard .....	12-26
D. Interior Building Components Suitable for Enclosures .....	12-27
1. Wood Trim and Drywall .....	12-27
2. Electrical Outlets and Vents .....	12-28
3. Ceilings .....	12-29
4. Floors .....	12-29
5. Stairs .....	12-30
6. Pipes .....	12-30
7. Door Frames .....	12-30
8. Plywood Enclosures .....	12-30
E. Exterior Enclosure Systems .....	12-30
1. Siding .....	12-30
2. Windows .....	12-31
3. Exterior Walls .....	12-32
F. Summary .....	12-32
Step-by-Step Summary for Paint Removal Methods .....	12-33
IV. Paint Removal Methods .....	12-35
A. Introduction .....	12-35
B. Prohibited Methods .....	12-35
1. Open Flame Burning or Torching .....	12-35
2. Machine Sanding or Grinding Without a HEPA Exhaust Tool .....	12-35
3. Uncontained Hydroblasting or High-Pressure Water Wash .....	12-36
4. Abrasive Blasting or Sandblasting .....	12-36
C. Methods Not Recommended .....	12-37
1. Dry Scraping .....	12-37
2. Chemical Paint Removers Containing Methylene Chloride .....	12-37
D. Recommended Methods of Paint Removal .....	12-37
1. Heat Guns .....	12-37
2. Mechanical Removal Methods .....	12-39
3. Chemical Removal Methods .....	12-41
E. Waste Disposal .....	12-45



Step-by-Step Summary for Soil and Exterior Dust Abatement ..... 12-47

V. Soil and Exterior Dust Abatement ..... 12-49

- A. Introduction ..... 12-49
- B. Soil Abatement Methods ..... 12-49
  - 1. Soil Removal and Replacement ..... 12-50
  - 2. Soil Cultivation ..... 12-53
  - 3. Soil Cleaning ..... 12-53
  - 4. Paving ..... 12-54
- C. Exterior Dust Control ..... 12-54
  - 1. Types of Equipment ..... 12-54
  - 2. Evaluation of Equipment ..... 12-55
  - 3. Removal of Heavy Accumulation ..... 12-56
  - 4. Vacuum Cleaning ..... 12-56





# Abatement: How To Do It

1. Have a risk assessment or paint inspection performed by a certified risk assessor or a certified inspector technician who is independent of the abatement contractor.
2. Develop a site-specific lead hazard control plan based on the hazards identified and financing available. Select the appropriate interior and/or exterior Worksite Preparation Level (from Chapter 8).
3. Have the contractor obtain any necessary building or waste permits; notify local authorities if the local jurisdiction requires it.
4. Together with the contractor (or designer or risk assessor), select specific building component replacement items, enclosure materials, paint removal equipment and/or chemicals, tools, and cleaning supplies. Consider waste management and historic preservation implications of the selected treatment.
5. Develop specifications (usually for large projects only).
6. Schedule other construction work so that leaded surfaces are not inadvertently disturbed and unprotected workers are not placed at risk. Include time for clearance examinations and laboratory dust sample analysis in the scheduling process (see Chapters 3 and 15).
7. Select a certified abatement contractor using the lowest *qualified* bidder.
8. Conduct a preconstruction conference to ensure the contractor fully understands the work involved (for large projects only).
9. Notify residents of the dwelling and adjacent dwellings of the work and the date when it will begin. Implement relocation (if appropriate).
10. Correct any existing conditions that could impede the abatement work (e.g., trash removal, structural deficiencies).
11. Post warning signs and restrict entry to authorized personnel. Implement the worksite preparation procedures.
12. For large projects only, consider conducting a pilot project to determine if the selected abatement method will actually work (pilot projects are sometimes completed before step 4).
13. Collect preabatement soil samples, which may not have to be analyzed until postabatement soil samples have been collected, analyzed, and compared to clearance standards. If postabatement soil levels are below applicable limits, the preabatement samples need not be analyzed (see Chapter 15).
14. Execute abatement work. See the other sections of this chapter for Step-by-Step Summaries for building component replacement, enclosure, paint removal, and soil abatement methods. Observe local or State regulations if applicable.
15. Store all waste in a secure area and make sure it is properly labeled with an accumulation start date (see Chapter 10).
16. Conduct daily and final cleanup (see Chapter 14). Execute waste disposal procedures.



## Step-by-Step Summary (continued)



17. Have an independent, certified inspector technician or risk assessor conduct a clearance examination after waiting at least 1 hour after cleanup has been completed to let dust settle (see Chapter 15).
18. If clearance is not achieved, repeat cleaning and/or complete abatement work. Repeat clearance examination and, if clearance is achieved, obtain any required formal release or certificate of completion required by the U.S. Department of Housing and Urban Development (HUD) or local authorities.
19. Pay contractor and clearance examiner.
20. Conduct periodic monitoring and reevaluation of enclosure systems (if applicable) or lead-based paint that was not abated as indicated in Chapter 6. Maintain records of all abatement, monitoring, reevaluation, and maintenance activities, and turn them over to any new owner upon sale of the property.



# Chapter 12: Abatement

## Section I

### I. Principles of Lead-Based Paint Hazard Abatement

#### A. Longevity of Abatement

Abatement is the removal of either the building component or the paint itself or the near-permanent enclosure of lead-based paint hazards. From a public health perspective, properly conducted abatement is the desired response to lead hazards. Abatement has two principal advantages: it provides a long-term solution, and little (if any) monitoring or reevaluation of the treated surface is necessary since failure is less likely to occur. Abatement treatments provide a higher margin of safety than interim controls since the effectiveness of the work is less dependent on resident action, maintenance of housing stock, the conscientiousness of property managers, and the attention of maintenance workers during repair.

As used in this chapter, abatement can mean either correction of lead-based paint hazards (as defined in Title X) or treatment of all lead-based paint (as currently practiced in the U.S. Department of Housing and Urban Development (HUD) public and Indian housing program, where all lead-based paint is abated during rehabilitation work or when a child with an elevated blood lead level is identified). The methods explained in this chapter apply to abatement of both lead-based paint hazards and lead-based paint.

Interim controls, abatement, or a combination of the two are acceptable methods of addressing lead-based paint hazards. In contrast to interim controls, lead-based paint abatement refers to a group of measures that can be expected to eliminate or reduce exposures to lead hazards for at least 20 years under normal conditions. Since 20 years is the expected lifespan of many commonly used building components,

abatement is the closest one can get to a “permanent” solution in housing. The abatement methods described in this chapter should be capable of lasting 20 years under typical conditions. Any methods developed in the future that also last 20 years will be acceptable as abatement methods. This orientation toward performance standards should provide owners and the abatement industry with opportunities for innovation and flexibility, ensuring that the abatement method selected is the one that is most cost-effective for a particular component.

The term “abatement” also includes a number of other activities that are not directly related to the work itself, but that must be included in the overall effort for the abatement to be successful. These activities include lead hazard evaluation, planning, cleaning, clearance, and waste disposal and are covered elsewhere in these *Guidelines*. The reader must study and understand the material in these other chapters prior to undertaking an abatement project. This chapter alone does not provide all the information necessary to complete a successful abatement job.

The definition of abatement (as used in this document) is different than the “traditional” abatement practices used in some local jurisdictions. Traditional abatement methods often involve dry scraping deteriorated paint, repainting, and dry sweeping without clearance. These methods are known to make leaded dust more accessible to young children and are therefore often counterproductive. Performed inadequately, or without sufficient protection, abatement is known to increase lead exposures to children (Amitai, 1987; Chisholm, 1985; Farfel, 1990; Rabinowitz, 1985a). When performed properly, abatement is known to be effective (Amitai, 1991; Staes, 1994; HUD, 1991; Jacobs, 1993a; Farfel, 1994; Staes and Rinehart, 1995).

Proper abatement refers to any measure designed to permanently eliminate lead-based paint hazards in accordance with standards

established by the U.S. Environmental Protection Agency (EPA) Administrator pursuant to Title IV of the Toxic Substances Control Act (TSCA). Abatement strategies include removal of lead-based paint; enclosure of lead-based paint; encapsulation of lead-based paint (according to the standards and procedures set forth in Chapter 13); replacement of building components coated by lead-based paint; removal of lead-contaminated dust; removal of lead-based paint from painted building components (as a last resort); removal or covering of lead-contaminated soil with a durable covering (not grass or sod, which are considered interim control measures); and preparation, cleanup, disposal, postabatement clearance testing, recordkeeping, and monitoring (if applicable).

More than any other abatement method, removal of lead-based paint involves the greatest degree of disturbance and dust generation. Therefore, onsite removal of lead-based paint from a substrate should be carried out only if abatement rather than interim control is required and no other abatement method is feasible. For example, removal of paint from metal doorframes may be the only feasible abatement option, especially if the frames cannot be removed or enclosed and the paint cannot be stabilized. Paint removal may increase the level of lead in household dust and make effective cleaning more difficult. Even if dust clearance standards are met, any increase in leaded dust levels over baseline levels means some increase in exposure. Furthermore, all removal methods leave behind some residues embedded in the substrate, which could continue to pose a hazard if the surface from which the paint is removed is later disturbed.

Therefore, paint removal is the most invasive of abatement methods and should be avoided if possible. Enclosure and building component replacement are the least invasive and most preferred of the abatement methods.

Abatement also offers the greatest challenge to planning, since it is often performed in the context of other building construction work, while interim controls are more likely to be performed alone or as part of other maintenance work.

In fact, many forms of abatement require special construction skills in addition to protective measures and dust control techniques. For example, one of the most common forms of lead-based paint abatement is window replacement. Abatement contractors need to possess adequate carpentry skills to install (for example) new windows, as well as the demolition, dust containment, and cleanup skills held by abatement contractors. While providing some guidance, this chapter is not intended to impart carpentry, painting, resurfacing, and other construction knowledge required for most types of abatement. Abatement contractors should either subcontract this type of construction work or acquire the necessary construction skills before the job begins. Of course, all construction work must be performed in accordance with local code requirements and all abatement work must be done by certified firms and individuals.

Many forms of abatement can be integrated into construction work, which provides an opportunity to install systems that will have long-term impact. For example, whenever building components, such as doors and windows, are replaced, the *Guidelines* recommend that they be replaced with products that are more energy-efficient. This will help reduce energy consumption and increase cost-efficiency.

EPA is establishing standard training curricula and regulations for the training and certification of all individuals engaged in lead-based paint risk assessment, inspection, and abatement, and minimum performance standards for the purpose of certifying those individuals who supervise lead abatement projects and conduct clearance examinations. EPA's regulations will generally be implemented through State programs. All abatement contractors and firms must be certified to perform this type of work, and all abatement workers must be trained and certified. Certification of abatement contractors and completion of clearance examinations by independent, certified risk assessors or inspector technicians ensures that abatement work is conducted properly and safely.

For exterior work, preabatement soil samples should be collected but not necessarily analyzed



until postabatement soil samples have been collected, analyzed, and compared to clearance standards. If postabatement soil levels are below applicable limits, the preabatement samples need not be analyzed (see Chapter 15).

### B. Prohibited Abatement Methods

Some techniques are prohibited because they are known to produce extremely high levels of lead exposure and result in dwellings that are difficult if not impossible to clean up.

The techniques shown in Table 12.1 are prohibited in the residential setting under HUD regulations (HUD, reserved) and several State regulations (Massachusetts, Maryland, Minnesota, and Rhode Island).

### C. Periodic Monitoring and Reevaluation

Compared to interim controls, one of the chief advantages of abatement is that owner monitoring and professional independent reevaluation are either unnecessary (in the case of complete lead-based paint removal) or required only infrequently (in the case of enclosure), since abatement measures are much less likely to fail (see Chapter 6). This minimizes the expense, cost, and time associated with reevaluation.

Abatements can be undertaken after inspections or risk assessments determine the presence of lead-based paint or other lead hazards (see

Chapters 3 and 5 for a description of the differences between risk assessments and inspections). If this initial identification phase is not completed before abatement, then all painted surfaces must be assumed to contain lead-based paint above the regulatory limit. This may be cost-effective if it is likely that all surfaces that might be treated contain lead-based paint or if the housing unit is to be rehabilitated and all surfaces and components either covered or replaced.

The cost of carefully conducted inspections or risk assessments, however, is usually recovered by a more focused abatement effort, especially when component replacement or enclosure is considered. The cost savings of a more targeted abatement effort based on complete testing are noteworthy in the case of abatement as opposed to interim controls, since the costs of abatement are initially much higher than interim controls.

#### 1. Recordkeeping

Recordkeeping is essential for all abatement methods, including removal. The location of enclosed or encapsulated lead-based paint should be made known to future residents, who may undertake remodeling or repair efforts that could reexpose the hazard. Depending on the jurisdiction, the location of enclosed or encapsulated lead-based paint may need to be filed with the appropriate municipal agency for future reference when issuing construction permits for renovation. The absence of lead-based

Table 12.1 Prohibited Lead-Based Paint Abatement Methods

<ol style="list-style-type: none"> <li>1. Open flame burning or torching (includes propane-fueled heat grids).</li> <li>2. Machine sanding or grinding without HEPA local vacuum exhaust tool.</li> <li>3. Uncontained hydroblasting or high-pressure wash.</li> <li>4. Abrasive blasting or sandblasting without HEPA local vacuum exhaust tool.</li> <li>5. Heat guns operating above 1,100 °F.</li> </ol> <p><b>Methods that may be prohibited in some jurisdictions and that are not recommended by HUD:</b></p> <ol style="list-style-type: none"> <li>1. Methylene chloride paint removal products.</li> <li>2. Dry scraping (except for limited surface areas).</li> </ol>
---

paint should also be made known to future occupants, in order to avoid unnecessary testing expenses.

#### D. Types of Abatement

This chapter covers four types of abatement:

- ◆ Building component replacement.
- ◆ Enclosure systems (this section does not include encapsulation, which is addressed in Chapter 13).
- ◆ Onsite and offsite paint removal.
- ◆ Soil removal or covering.

The available information on paint abatement methods is summarized in Table 12.2.

Experimental and innovative abatement techniques are currently being developed. The reader should not conclude that a particular method is not permitted simply because it is not discussed here. With the exception of the prohibited techniques listed above, new techniques should be developed, studied, and reported to HUD, the Centers for Disease Control and Prevention (CDC), EPA, and other Government agencies for distribution to the public.

#### E. Encapsulation

Encapsulants are coatings or rigid materials that rely on adhesion to a lead-based painted surface and are not mechanically fastened to the substrate. Because the performance standards mandated by Title X have not yet been developed, encapsulants are considered separately in Chapter 13. "Enclosures" (not to be confused with encapsulants) are defined as durable, rigid construction materials that are mechanically fastened to the substrate with screws, nails, or other mechanical fastening system that can be expected to last at least 20 years under normal conditions. These *Guidelines* do not consider encapsulation to be the same as enclosure. Depending on the particular circumstances and product, encapsulation can be either a form of paint stabilization (an interim control) or abatement (see Chapter 13).

#### F. Relationship to Renovation, Repainting, Remodeling, Rehabilitation, Weatherization, and Other Construction Work

Many forms of abatement involve the same physical work as other types of construction often performed in housing. In many cases, only the intent of the work differs. Lead-based paint abatement is intended to produce conditions that prevent lead poisoning. Other construction work is intended to, among other things, improve aesthetic living conditions, bring the dwelling up to code, preserve historical evidence, and promote energy efficiency. For example, window replacement could be considered to be a lead abatement method, renovation work, or weatherization work all at the same time.

While the intentions of each of these activities may differ, experience shows that many of them can be combined in order to yield savings. In the public housing program, for example, most of the abatement now underway occurs in the context of housing modernization or rehabilitation work. This approach has proven to be feasible and cost-effective.

Congress recognized the wisdom of combining lead abatement with rehabilitation work. In Section 1012 of Title X, any residential construction job receiving more than \$25,000 per dwelling unit in Federal funds is *required* to have lead-based paint hazards abated. If \$5,000 to \$25,000 per dwelling unit in Federal funding is received, either abatement or interim controls must be implemented.

Finally, lead abatement procedures cannot guarantee that children will not be exposed to lead in the future. Enclosure systems could fail, exposing the hazard again. Soil coverings could also fail, resulting in excessive exposures. Surfaces that were made cleanable may deteriorate or may not be kept clean, allowing leaded dust levels to reaccumulate to hazardous levels. Nevertheless, abatement constitutes the most extensive and protective intervention presently available. If practiced properly, abatement will greatly reduce the risk of lead poisoning.



Table 12.2 Comparison of Lead-Based Paint Abatement Methods

Attributes	Method										
	Removal							Enclosure			
	HEPA Needle Gun	Heat Gun	HEPA Vacuum Blast	HEPA Sand	Remove/Replace	Caustic Paste	Offsite Stripping	Plywood Paneling	Gypsum	Prefab Metal	Wood, Metal, Vinyl, Siding
<b>Skill Level</b>	High	Moderate	High	Moderate	High	Moderate	Moderate	Moderate	Moderate	High	Moderate
<b>Esthetics</b>	Erodes surface	Gouges	Erodes surfaces	Gouges/roughens	Good	Gouges	Good	Good	Good	Good	Good
<b>Applicability</b>	Very low, limited to metal and masonry	Wide, can damage some components	Very low, limited to metal and masonry	Low, limited by surface contour	Wide, dependent on skill level	Wide, can damage some components	Low, limited to components	Wide, walls	Wide, walls and ceilings	Varied, limited by components	Wide, walls
<b>Lead Presence</b>	Removed	Largely removed	Largely removed	Largely removed	Removed	Largely removed	Largely removed	Remains	Remains	Remains	Remains
<b>Hazardous Waste Generation</b>	Moderate	Moderate	Moderate	Moderate	Potentially high, pending TCLP test	High	High, but maintained offsite	Low	Low	Low	Low
<b>Weather Limitations</b>	Moderate	High	Moderate	Moderate	Minimal	High	None	Minimal	Minimal	Minimal	Minimal
<b>Applicable to Friction Surface</b>	Some	Yes	Some	Some	Yes	Yes	Yes	No	No	Yes	No
<b>Speed of Methodology</b>	Moderate	Slow	Slow	Slow	Moderate	Very slow	Can be slow, requires coordination	Moderate	Moderate	Moderate	Moderate
<b>Training Required</b>	High	Moderate	High	Moderate	High	Moderate	Moderate	High	High	High	High

This table is continued on next page.

Table 12.2 Comparison of Lead-Based Paint Abatement Methods (continued)

Attributes	Method												
	Removal						Enclosure						
	HEPA Needle Gun	Heat Gun	HEPA Vacuum Blast	HEPA Sand	Remove/ Replace	Caustic Paste	Offsite Stripping	Plywood Paneling	Gypsum	Prefab Metal	Wood, Metal, Vinyl, Siding		
Capital Required	High	Low	High	Moderate	Moderate	Low	Moderate	Low	Low	High	Moderate		
Worker Protection Required	High	High	High	High	Moderate	High	Moderate	Low	Moderate	Low	Low		
Finish Work Required	Tentatively high	Moderate	Tentatively high	Moderate	Low	Moderate	Moderate	Wide	Wide	Limited	Wide		
Product Availability	Limited	Moderate	Limited	Limited	Wide	Moderate	Limited, strip shops decreasing	Moderate	Moderate	Long	Long		
Durability	Long	Long	Long	Long	Long	Long	Long	Moderate	Moderate	Moderate	Moderate		
Labor Intensity	High	High	High	High	High	High	Moderate	High	High	High	High		
Overall Safety	Moderate	Moderate	Moderate	Moderate	Very high	Moderate	High-high	High	High	High	High		
Surface Preparation	None	None	None	None	None	Minimal—adjacent areas	Minimal—hardware removal	Minimal	Minimal	Minimal	Minimal		
Cost	High	High	High	High	High	High	High	Moderate	Moderate	High	Moderate		

Source: Adapted from Dewberry and Davis, HUD Lead-Based Paint Federal Housing Administration (FHA) Abatement Demonstration Project.



# Building Component Replacement: How To Do It

1. Prepare the work area by selecting a Worksite Preparation Level (see Chapter 8). Plan how the new component will be installed. Whenever possible use new energy-efficient window, door, and insulating systems.
2. Prepare the hazardous building component for removal. Turn off and disconnect any electrical circuits inside or near the building component to be removed.
3. Lightly mist the component to be removed (unless electrical circuits are nearby).
4. Score all painted seams with a sharp knife.
5. Remove any screws, nails, or fasteners.
6. Use a flat pry instrument (crowbar) and hammer to pry the component from the substrate.
7. Remove or bend back all nails.
8. Wrap and seal bulk components in plastic and take them to a covered truck or secured waste storage area along pathways covered with plastic. Shovel any debris. See Chapter 10 for proper disposal methods.
9. HEPA vacuum any dust or chips in the area where the component was located.
10. Replace component (optional).
11. Conduct cleaning (see Chapter 14).
12. Conduct clearance and reclean if necessary.





## Section II

### II. Building Component Replacement

Building component replacement is defined as the removal of doors, windows, trim, and other building items that contain lead-based paint hazards and their replacement with new lead-free components. Component replacement is the most desirable abatement method because it offers a permanent solution to the lead-based paint problem. If done properly, it also minimizes contamination of the property and exposure of the workers. In addition, building component replacement can be integrated into general building rehabilitation activities. Components, such as doors and windows, should be replaced with more energy-efficient models, which will help to reduce energy consumption and increase cost efficiency.

Component replacement may be more expensive, however, especially for historic preservation projects, since new building components that match the originals may have to be custom made. For some historic preservation projects, replacement may not be permitted (see Chapter 18).

The skills required to perform building component replacement properly are similar to those of the skilled carpenter. For example, it is important to know how the various building components were joined so that they can be taken apart with minimal contamination and damage to adjoining surfaces.

For certain types of components, the owner may choose to simply remove them without replacement. This is acceptable as long as applicable codes are observed.

#### A. Worksite Preparation

The appropriate worksite preparation level should be selected based on the size of the building component, its state of deterioration, and the ease of removal. The more deteriorated

the component and the larger the surface area to be disturbed, the higher the worksite preparation level should be. Certified risk assessors or certified abatement supervisors or trained planners and designers can determine the appropriate level for a project (see Chapter 8).

#### 1. Security

Security of the premises is an important issue. If windows and doors are removed but not replaced on the same day, it may be necessary to install temporary barriers over window and door openings to prevent vandalism and theft overnight. Therefore, every effort should be made to remove and replace doors and windows on the same day.

#### 2. Waste Storage

While architectural components may or may not be regulated as hazardous waste (see Chapter 10), they still must be properly managed. All building components coated with lead-based paint should be stored in a secure, locked area. They should not be sold or released to anyone who might reinstall them in another dwelling.

### B. General Procedures for Building Component Replacement

- ◆ Using a garden sprayer or atomizer, lightly mist the component to be removed with water to help keep the dust down during the removal process. Before applying the water, be sure there are no electrical circuits inside the component. (If electrical circuits are present inside the component, they must be turned off and disconnected before removal. No water mist should be applied even if electrical circuits are turned off or de-energized.)
- ◆ Using a utility knife or other sharp instrument, carefully score all affected painted seams. This will provide space for a pry instrument and will minimize paint chipping and dust generation during removal.



Figure 12.1 Use a Pry Point Pad To Minimize Damage to Adjoining Surfaces During Component Removal.

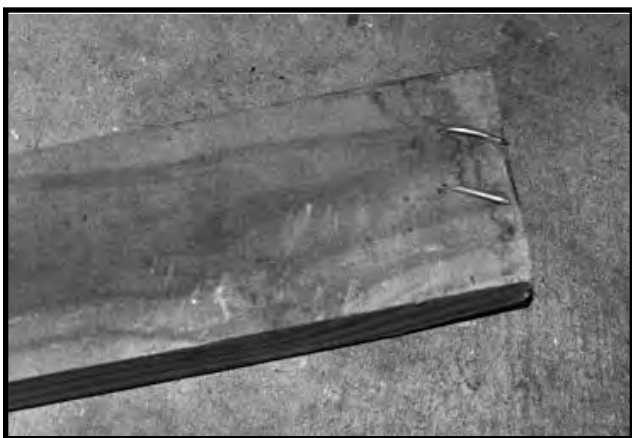

Figure 12.2 Bend Back All Nails on Removed Components.

- ◆ Remove any screws or other fasteners. Using a flat pry instrument and a hammer, carefully pry the affected building component away from the surface to which it is attached. The pry bar should be inserted into the seam at the nail (or other fastening device) at one end of the component and pressure applied. This process should be repeated at other fastening locations until the end of the component is reached. By prying in this manner, the component will be removed intact and chip and dust generation will be minimized. A pry point pad or softener may be required to minimize damage to adjoining substrates. Wider replacement trim can sometimes be used to cover adjacent area damage.
- ◆ Since there is often a considerable amount of leaded dust underneath or behind the component being removed, begin cleanup immediately after the individual component has been removed.
- ◆ Carefully remove or bend back all nails (or other fastening devices) and wrap the component in 6-mil plastic sheeting and seal with duct tape. Wrapping components in plastic may not be necessary if the dwelling is vacant and if the truck and the pathway to the truck are lined with plastic. Use a high-efficiency particulate air (HEPA) vacuum to remove any dust that may have accumulated behind the components as soon as they have been removed. Vacuuming may be performed by another person while the removal is underway. Preparing the area for the new component (e.g., squaring, reducing, or enlarging openings) may also release accumulated dust that should be removed. Dispose of wrapped components properly.
- ◆ Bring new lead-free components into the work area only after all dust-generating activity is complete and the dust cleaned up by at least one HEPA vacuuming.

## C. Removal and Replacement Procedures for Specific Components

### 1. Baseboards, Casings, and Other Trim

The term “other trim” applies to such components as window casings, interior sills (stools), aprons, door casings, baseboards (including caps and shoe moldings), chair rails, exterior fascia, soffits, shutters, and crown moldings. Components with lead-based paint should be removed as described in the previous section.

New lead-free components should be installed in a professional manner using standard carpentry practices. In situations where trim is being applied to lead-based painted walls, ceilings and floors that were enclosed, or casings for windows or doors where the jambs have been enclosed, the trim should be back-caulked before installation as an added precaution. “Back-caulking” refers to the application of caulk to the perimeter of the backside of rigid building materials to seal them before installation, preventing leaded dust from entering the living space through cracks and crevices. A high-quality caulk warranted for at least 20 years should be used.

### 2. Windows

The term “window” applies to the sash, the stop and parting beads, and the window jambs. Affected components should be removed as described in Section B. Window replacement can involve the removal of a wooden or metal unit and the installation of a wood, vinyl, or metal unit in its place. If the jamb is not removed, it can often be enclosed by the new window frame system, which should be caulked and fastened. The remaining exterior portion of the jamb, if any, can be wrapped with coil stock (aluminum or vinyl or equivalent) after back-caulking. In situations where window units must be replaced in kind (e.g., historic preservation), the jambs should be removed and replaced also to make sure that no friction surfaces coated with lead-based paint remain. Generally, friction surfaces should not be painted.



Figure 12.3a Remove and Replace Trim (interior).



Figure 12.3b Remove and Replace Trim (exterior).



Figure 12.4 Window Frame Enclosure System.



Figure 12.5 Window Replacement.

Depending on the building construction, it may be possible to remove the entire window system. The new lead-free components should be installed in a professional manner using standard carpentry practices.

### 3. Interior and Exterior Doors

Interior and exterior doors include the door-stops and doorjamb. Affected components should be removed as described above. Typical door replacement usually involves the removal of a wooden unit and the installation of a prehung wooden unit in its place. In this type of door replacement, the jamb is rarely removed, but is usually saved and enclosed with the new doorjamb after back-caulking. Wooden jamb extensions or coil stock, properly back-caulked, can be used to enclose any remaining portion of the jamb. In situations where prehung door units are not permissible (e.g., code requirements, historic preservation regulations), the original jamb should also be removed and replaced, if possible, to make sure that no friction surfaces coated with lead-based paint remain. If the jamb cannot be replaced, the stop should be removed and replaced with new material after carefully stripping the old jamb.

#### *Primers on Metal Doors*

An exception is provided for certain metal doors and frames. If it can be determined clearly that hazardous levels of lead on metal doors and frames reside only in the primers, and that the primers were factory-applied and are in sound condition, then the primers themselves need not be abated or removed. However, finish coats of paint that cumulatively contain lead of 1 milligram per square centimeter or greater will have to be treated as lead hazards. (The alternative standard of equal to or greater than 0.5 percent by weight may be used.) If laboratory analyses of samples of the field-applied finishes are negative, the metal doors and frames do not require abatement but should be monitored to ensure that the lead-bearing primer does not become defective. If the base metal is exposed while sampling the field-applied finish paint then the existence of a permanent bond

cannot be assumed and the entire sample should be analyzed for presence of lead. Any damage to the primer resulting from sample collection should be repaired immediately in a manner that restores the integrity of the primer coat.

For the metal doors and frames under this exception, primers should be intact and doors should be operating properly, free from impact or abrasion between moving parts that will damage any surfaces. If this exception for factory-applied primers is used, risk assessors should advise property owners or building managers of the importance of continued monitoring of the paint surfaces to ensure that subsequent surface deterioration or other factors do not result in exposing defective lead-based paint surfaces (the primers). Under this exception, property owners or building managers must commit to a plan for ongoing monitoring of the condition of the painted surfaces. The subsequent appearance of rust indicates a failure of the paint and primer, and the component must be abated.

Although unlikely, adhesion of the primer could be a problem. A simple “x” cut or cross-hatch test will show if this is a problem. If adhesion is poor, the paint will tend to flake away from a cut. An adhesion test should also give an indication of the number of coats, color of finish versus primer (which would be orange if it was pigmented with red lead or yellow if it was pigmented with lead chromate), and thickness of layers. Or course, other colors of lead-based paint may also be present. Any damage resulting from an adhesion test should be repaired immediately in a manner that restores the integrity of the primer and finish coats to prevent subsequent deterioration.

When it can be determined that lead-based paint is present in a field-applied coating over an intact factory-applied primer, and paint removal is the abatement method of choice, only the finish field-applied coatings need to be removed. An intact primer need not be removed.

#### 4. Kitchen and Bathroom Cabinets

Old lead-based painted kitchen and bathroom cabinets can be removed and replaced. Affected cabinets should be removed as described above. Lead-based paint on walls to which cabinets are attached should not be disturbed during cabinet removal. Applying masking tape around the cabinet perimeter and HEPA vacuuming immediately after removal will help to control leaded dust.

#### 5. Railings

Railings include the railing caps, banisters, posts and spindles (balusters), and newel posts can be removed and replaced. Railings may or may not be part of a stair system. Affected components should be removed as described in Section B. New lead-free components should be installed in a professional manner using standard carpentry practices.

Metal railings and other grillwork can be removed and taken offsite for contained abrasive blasting or other forms of paint removal, then reinstalled after repainting.

#### 6. Exterior Siding

Exterior siding includes any materials used on a dwelling's exterior walls. Siding of concern is generally painted wood or brick. Under most conditions, siding will have to be abated through enclosure. However, in restoration



Figure 12.6 Exterior Siding Removal and Replacement.



Figure 12.7a Line Walking Surfaces With Plastic.



Figure 12.7b Line Pathways With Plastic.

or historically significant projects, it may be replaced. In such situations, the affected siding should be removed as described above. Care must be taken to avoid contamination of soil, walkways, window air conditioners, and the building interior.

### 7. Interior Walls

If abatement is performed along with gut rehabilitation, old lead-based painted interior walls and ceilings may be removed and replaced. This activity, unlike those previously described, is more like demolition work. In addition to the layers of 6-mil plastic used to protect the floors from contamination, sheets of plywood should

be placed over the plastic to protect it from damage during aggressive demolition, and to make cleanup of debris easier. Prior to demolition, affected areas should be sprayed lightly with water. Workers should wear ribbed rubber boots when walking on slippery, wet plastic. If ladders must be used, the plastic should be punctured to provide secure anchoring of the footings to the surface underneath. Ladder footings should not be placed on top of the plastic, since this will create a slip hazard. Excessive water should not be applied, and the creation of puddles and streams that may flow through breaks or gaps in the containment should be prevented.

Plaster walls coated with old lead-based paint should generally not be removed, since a great deal of dust will be generated. Enclosure is usually a better option.

### D. Transportation and Storage of Waste

Building component replacement and demolition generate a considerable amount of waste material. Lead-contaminated building components and demolition debris should be handled carefully, even if they are not regulated as hazardous wastes (see Chapter 10). Bulk debris such as doors, windows, and trim should be wrapped in 6-mil plastic and sealed with tape. Smaller debris should be swept into 6-mil plastic bags after spraying.

All debris should be removed from the site as soon as possible. In larger jobs where a dumpster is being used, it may be possible to eliminate the wrapping and bagging of bulk debris as long as the dumpster has a lockable lid and is lined with plastic and secured with a fence and signs. Pathways to the dumpster should be lined with plastic so as not to contaminate the area.

Contaminated building components and demolition debris should be transported in covered vehicles to an appropriate disposal facility. Old building components coated with lead-based paint must not be recycled. See Chapter 10 for a full discussion of hazardous and nonhazardous waste disposal.



# Enclosure: How To Do It

1. Stamp, label, or stencil all lead-based painted surfaces that will be enclosed with a warning approximately every 2 feet both horizontally and vertically on all components. The warning should read: "Danger: Lead-Based Paint." Deteriorated paint should not be removed from the surface to be enclosed.
2. Select a Worksite Preparation Level (see Chapter 8).
3. Attach a durable drawing to the utility room or closet showing where lead-based paint has been enclosed in the dwelling.
4. Plan for annual monitoring of the enclosure by the owner. An independent inspector technician or risk assessor should evaluate the integrity of the enclosure according to the reevaluation schedule in Chapter 6 *and* after any significant damage due to plumbing or roof leaks, tornadoes, hurricanes, floods, earthquakes, etc.
5. Repair unsound substrates and structural members that will support the enclosure, if necessary.
6. Select appropriate enclosure material (drywall or fiberboard, wood paneling, laminated products, ridged tile and brick veneers, vinyl, aluminum, or plywood).
7. Install extension rings for all electrical switches and outlets that will penetrate the enclosure.
8. If enclosing floors, remove all dirt with a HEPA vacuum to avoid small lumps in the new flooring.
9. Seal and back-caulk all seams and joints. Back-caulk means applying caulk to the underside of the enclosure.
10. When installing enclosures directly to a painted surface, use adhesive and then anchor with mechanical fasteners (nails or screws).
11. Conduct cleanup.
12. Have a certified risk assessor or inspector technician conduct clearance testing and provide documentation and a Statement of Lead-Based Paint Compliance.



## Section III

### I. Enclosure Methods

#### A. Definition

“Enclosure” is the installation of a rigid, durable barrier that is mechanically attached to building components, with all edges and seams sealed with caulk or other sealant. Surfaces with lead-based paint are enclosed in order to prevent access and exposure and to provide a “dust-tight” system. Unlike encapsulation, the enclosure system is not dependent on the painted surface of the substrate for its durability. Enclosures should have a design life of at least 20 years. While adhesives are frequently used for initial mounting purposes and for assistance in covering the lead-based painted surface with the enclosure material, it is primarily mechanical fasteners that give enclosures their longevity.

Standard construction materials are employed to create a solid and relatively rigid end product (see Appendix 7.2 for a description of materials commonly employed for lead-based paint enclosure). The primary differences between enclosure for lead-based paint and ordinary construction includes careful sealing of all edges, joints, and seams to create a dust-tight (not necessarily airtight) enclosure; site containment; worker safety (particularly during any needed surface or substrate repairs); and special cleanup. There is generally little or no hazardous waste disposal and little degradation of the lead-based paint as part of the enclosure process, unless substrate repairs are necessary. The hazard and expense of removing deteriorated paint can be avoided when the enclosure material is mounted flush to a structurally sound lead-based painted substrate and all the seams are sealed. This method produces little leaded dust (HUD, 1991). These advantages hold down labor costs compared to paint removal and building component replacement, although cleanup and clearance are still required. A lower level of containment can often be used since less dust is generated.

For broad surfaces such as walls, ceilings, floors, and siding, enclosure is often considerably

cheaper and less hazardous than building component replacement and paint removal. However, enclosure does not remove lead from the property; instead, it makes the dwelling lead-safe.

#### B. Longevity of Enclosures

There is little doubt that hurricanes, earthquakes, tornadoes, and flooding can substantially compromise an enclosure's viability. Less dramatic but more common events can also increase the risk of lead exposure, such as damage to the enclosure by the occupant or water damage from a leaking roof, overflowing tubs, or broken pipes. Any type of enclosure is potentially vulnerable to water damage. Future occupants can also be threatened by remodeling endeavors that break through the enclosure.

##### 1. Labeling of Enclosed Surfaces

To prevent the breach of an enclosure, a few simple safety rules are relevant. The surface to be enclosed should be labeled (behind the enclosure), horizontally and vertically, approximately every 2 feet with a warning, “Danger: Lead-Based Paint.” The stamp lettering should be done in permanent ink.

A durable drawing of the property floor plan should be mounted on a sturdy metal or wood base and affixed with screws to a wall in the utility room next to the electrical panel or at any other closet location that can be easily seen by maintenance personnel. The drawing should be covered with plastic for protection. Enclosures should be highlighted on the diagram and identified as hazardous (see Figure 12.9 for an example of such a diagram).

##### 2. Monitoring Enclosure Integrity

A visual evaluation of the enclosed surfaces should be conducted by owners or their representative at least every year or whenever water or other damage is reported. Residents should also examine the enclosure periodically. Enclosure integrity should be evaluated professionally by a certified risk assessor according to the schedule in Chapter 6. A signed and dated report of the risk assessor's observations, which



Figure 12.8a Label Surfaces With a Stamp Before Enclosure.



Figure 12.8b Caulk the Seams of a Window Frame Enclosure System.

also indicates the enclosed surface locations, should be retained by the owner, with copies available to the residents.

It is a simple matter to repair an enclosure using conventional construction techniques. The repair history of the enclosure should be maintained in the owner's records.

Depending on the jurisdiction, the original lead-based paint risk assessment or inspection report, the clearance report, and a copy of the enclosure drawing may be retained by the municipality as part of its standard records for that property. The reports also may be subject to disclosure requirements during the sale of the dwelling. If a permit is obtained to do renovation work, if demolition of the dwelling is undertaken, or if the title and deed are transferred, the history of the lead-contaminated surfaces hidden behind enclosures will caution future workers and property buyers. Leases should also disclose the location of enclosed lead-contaminated surfaces.

### 3. Unsound Substrates

Any substrate material can be enclosed, including plaster, concrete block, brick, and concrete. All soft, moveable, or otherwise structurally unsound structural members should be repaired prior to enclosure if they are needed to support the enclosure. If repair is not feasible, then the defective area will need to be removed and enclosure will not be possible. Hazards associated with preparing the site for enclosure increase as more remedial work is needed. Structural repairs may require lead-based paint removal or component replacement, with all the accompanying safety protocols these practices entail. If the substrate is sound but the paint deteriorating, stabilization or removal of deteriorated paint before the enclosure is installed should *not* be done due to dust generation.

Figure 12.9 Example of a Diagram Showing the Location of Lead-Based Paint Enclosures.

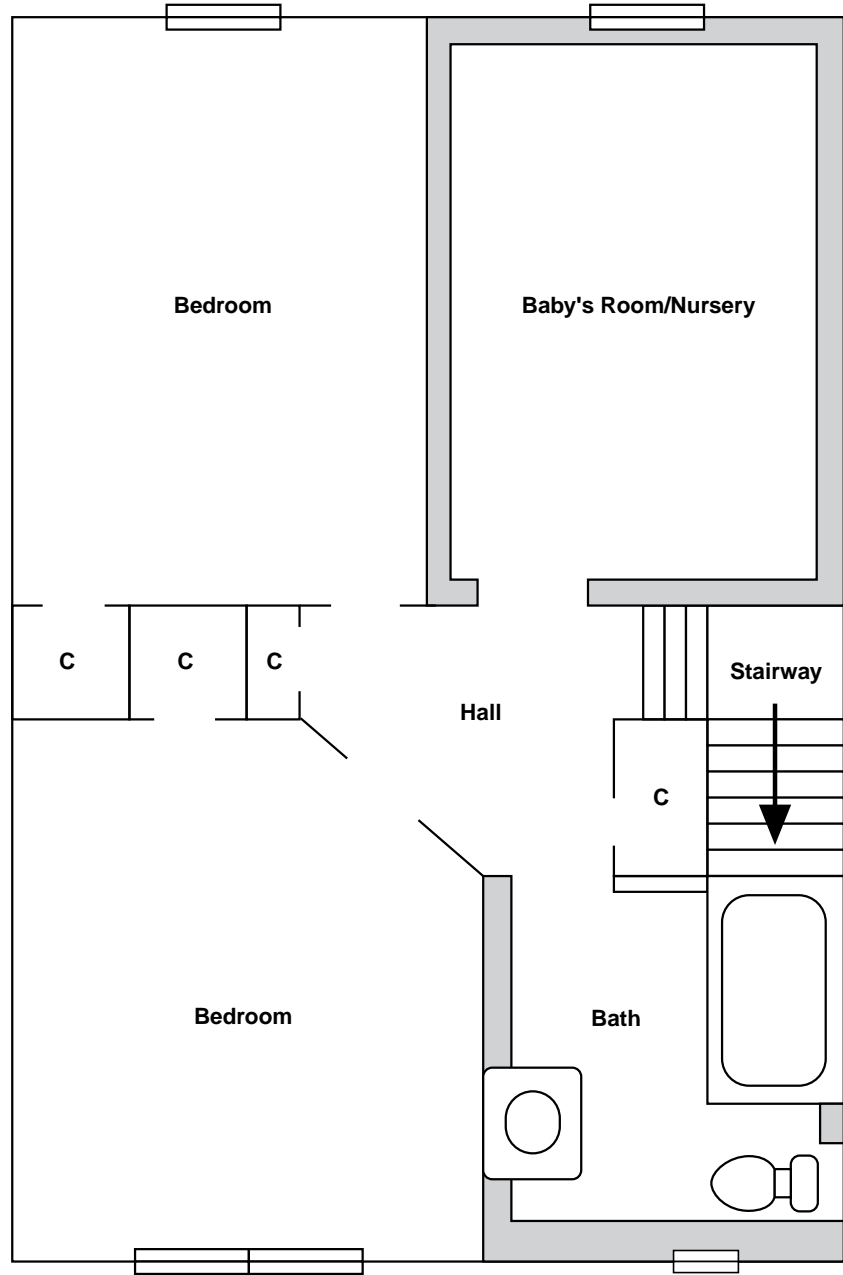

C = CLOSET

== = WINDOWS

Denotes Lead-Based Paint Enclosures In the Bathroom and Baby's Nursery

## C. Interior Surface Enclosure Materials

### 1. Wood Paneling

Wood paneling is an appropriate enclosure material, except for ceilings. It is of limited use, however, because it is difficult to seal seams around electrical outlets; switch boxes; and heating, ventilation, and air conditioning (HVAC) registers. There should be no gaps in the seams, outlets, boxes, and registers, which should all be screwed directly to the paneling and to any framing behind the panels. All seams should be caulked. Paneling made of composite board backing materials is vulnerable to dampness, particularly in below-grade situations such as basements. In some instances, the use of these materials may violate building and/or fire codes. On the other hand, plywood paneling may be stronger, more impact-resistant, and more water-resistant than other enclosure materials, such as drywall.

Paneling can be glued and mechanically fastened directly to the substrate, but the appearance is improved when the area to be covered is first furred or framed out and the paneling is anchored to these braces. The paneling should not extend past the depth of door or window frames or other trim pieces. Baseboards can be removed and the new cove base then glued directly to the paneling. Even heavy grades of paneling flex and vibrate when receiving mild impact. Over time this could compromise the seal of the seams that join the paneling with other building components. Joints and edges must be fully supported; furring strips should be installed at the appropriate distance from each other, usually 12 inches apart. All seams at these transition points should be caulked before panel trim and corner moldings are installed as finish pieces.

### 2. Laminated Products

Laminated wall sheeting products, such as Marlite™, are designed to withstand surface moisture and are commonly used in bathrooms and kitchens. Their surfaces have a high sheen and clean easily. However, they may become

defective when moisture gets behind the board's placement. This can occur from a leaking pipe or a seam opening in the bathtub/shower area. When a significant leak is detected, the enclosure must be reexamined.

### 3. Ridged Tile and Brick Veneers

Plastic and ceramic tile, synthetic brick and stone veneers, and other similar products are either glued or cemented directly to the painted surface. These products qualify as rigid encapsulants rather than enclosures, since they are not mechanically fastened to the substrate. Regardless of whether they are enclosures or encapsulants, they tend to be inappropriate for broad application, since the cost associated with labor and materials is often prohibitive for anything more than incidental use.

### 4. Drywall and Fiberboard

The steps to install drywall and fiberboard are shown in Table 12.3 and detailed specifications are provided by the Gypsum Association (202)289-5440 on the two topics listed below:

- ◆ Recommendations for covering existing walls and ceilings with gypsum board (GA-650-86).
- ◆ Using gypsum board for walls and ceilings (GA-201-90).

Gypsum drywall or fiberboard is a very common and cost-effective interior finish. It is not difficult to locate skilled workers to install this product. Training materials are available from trade groups (Gypsum Association, 1993a, 1993b). When applied directly to a surface, the drywall is generally glued in place with construction adhesives and then mechanically fastened to the studs or structure behind the plaster. The screws must be long enough to go through the drywall, the plaster, and the wire mesh or lath and extend an inch into the stud or structure. To avoid having dust escape from the screw hole as the drilled screw displaces plaster, a dab of shaving cream can be applied to the area to be drilled.



Moisture-resistant greenboard should be installed in damp areas. It is difficult to completely control the long-term damaging effects of a severe moisture problem without invasive waterproofing and/or water diversion from the exterior of the property. Any type of enclosure is potentially vulnerable to water damage.

Quarter-inch-thick drywall tends to conform to the contours and imperfections of the original substrate or wall, compromising the appearance of the finished product. To avoid this, use of 3/8-inch-thick (minimum) drywall is recommended. The enclosed wall may in fact look much improved over the original wall. If the original wall surface is highly irregular, it may be necessary to install furring strips 12 inches apart and use 1/2-inch-thick drywall to improve the appearance. If 1/4-inch-thick drywall is used, it must be applied in accordance with the manufacturer's specifications (Gypsum Association, 1993a and 1993b).

#### D. Interior Building Components Suitable for Enclosures

All joints between drywall pieces should be taped and spackled with joint compound.

Wherever the drywall meets wood framing or any other finish material (including electrical devices and HVAC registers), the seams should be sealed with a caulk or other sealant that has at least a 10-year warranty. Similarly, where sealed pipes penetrate an enclosure, the opening around the pipe must be sealed. Drywall is painted when installation is complete. Fastening schedules are available from industry trade groups (Gypsum Association, 1993a, 1993b).

#### 1. Wood Trim and Drywall

The profile of the wood trim on windows and doors must be evaluated before overlaying an adjacent wall with drywall; the wall finish should protrude past the depth of the moldings. In homes built before 1960, this problem is less frequent because the trim tended to be more ornate and generally of thicker wood. Regardless of age, the problem is more apt to occur in multifamily public housing and institutional settings where the construction is basic and trim is thin.

If the drywall overlay is too thick, it may be possible to remove the baseboard and run the drywall to the floor. The baseboard can then

Table 12.3 Steps To Install Drywall and Fiberboard on Interior Walls

<ul style="list-style-type: none"> <li>◆ Check to make sure the depth of the trim will accommodate the thickness of the drywall (minimum of 3/8 inch preferred). If it does not, this method may not be suitable.</li> <li>◆ Set up the plastic containment of the work area (see Chapter 8).</li> <li>◆ Remove any trim being disposed of, and install the drywall over any cavity left by the removed moldings, except large cavities over 16 inches in any direction. Repair any structural deficiencies.</li> <li>◆ Repair or remove any "soft" wall areas. Removal of painted plaster generates a great deal of leaded dust.</li> <li>◆ Use construction adhesive to glue the drywall directly to the surface being enclosed.</li> <li>◆ Screw the drywall to the studs behind the existing wall.             <ul style="list-style-type: none"> <li>a. Caulk all seams that meet molding.</li> </ul> </li> <li>◆ Use extension rings to bring out electrical devices flush with the new gypsum-based drywall and retrofit any HVAC registers.             <ul style="list-style-type: none"> <li>a. Caulk all seams.</li> </ul> </li> <li>◆ Tape and finish the drywall.</li> <li>◆ Prime and paint the finished area, as well as the unenclosed surfaces in the same room so that all walls match the new installation. (See specifications and recommendations from the Gypsum Association.)</li> </ul>
---



Figure 12.10a Use of Tyvek on Building Exteriors Prior to Enclosure.

be reinstalled over the new drywall (unless the baseboard itself presents a lead hazard, in which case it should be replaced). Obviously, care must be taken to avoid breaking the original baseboard during its removal. The seam at the bottom of the drywall should be sealed with caulk prior to the installation of the baseboard or cove base.

## 2. Electrical Outlets and Vents

All electrical devices, including switches and outlets, will need extension rings in order to bring those fixtures out flush with the new drywall overlay. A sealant or caulk should be used

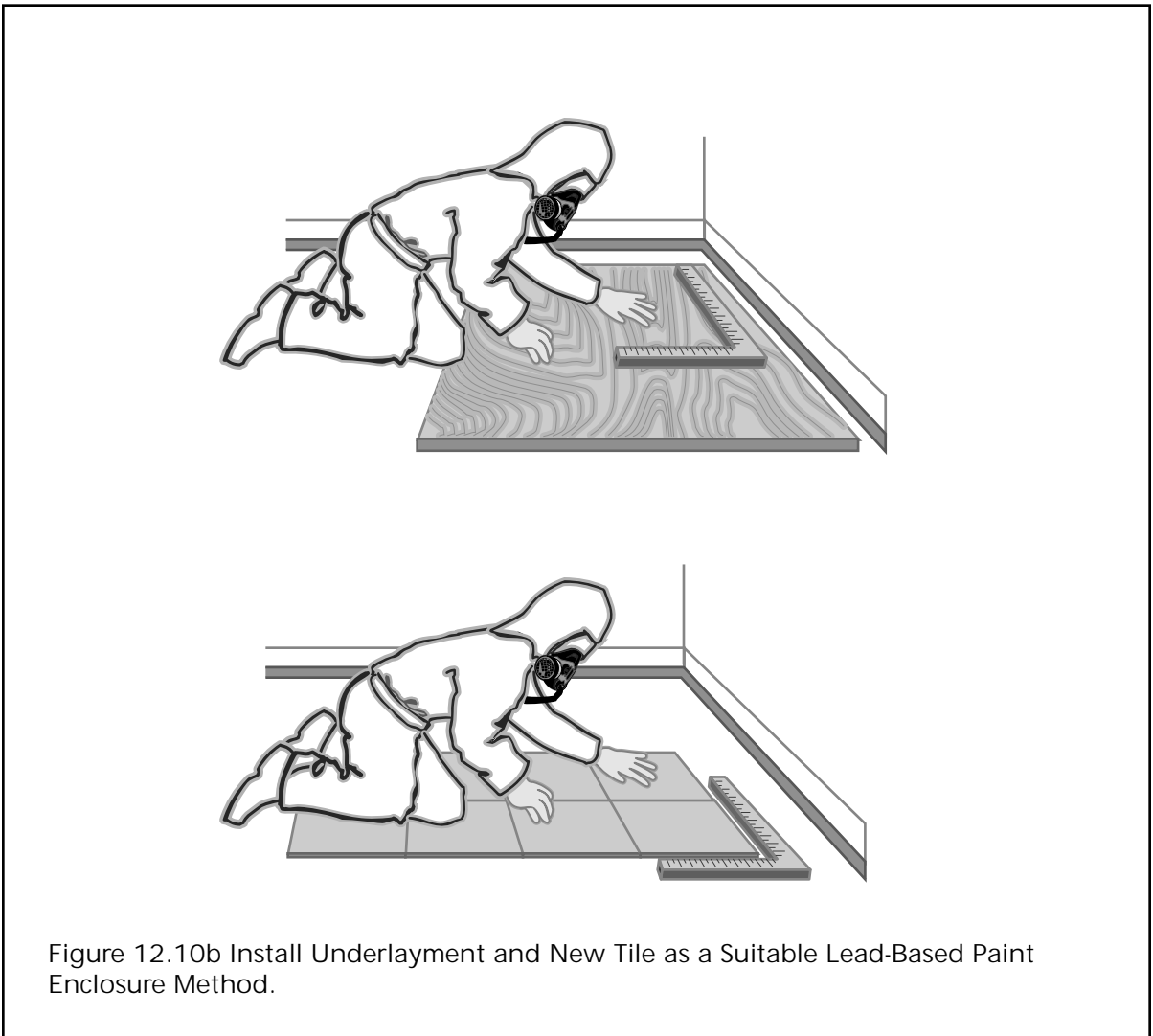

Figure 12.10b Install Underlayment and New Tile as a Suitable Lead-Based Paint Enclosure Method.



at cutouts for electrical boxes. Similarly, all grillwork at openings for heat vents and cold air returns should be retrofitted. These are minor but necessary operations in the drywall enclosure process.

### 3. Ceilings

Ceilings are more difficult to enclose than walls. Drywall applied directly to the ceiling will frequently result in an uneven appearance because there may not be a smooth transition from one board edge to the next. The solution is to draw a chalk line, usually every 16 inches on center, so that metal hat channels (or metal furring channels) or wood furring strips can be screwed into each ceiling joist. Three- to four-inch screws should be used to ensure that the screw penetrates the hat channel, plaster (or other substrate), and the wire mesh holding the plaster enough to bite firmly into the joist. The hat channel may be shimmed to get a perfectly level finished surface.

Next the drywall should be affixed to the hat channel for an excellent finished product. An extension ring will be needed for ceiling light fixtures. Prior to lowering the ceiling slightly, the contractor should be confident that there is no interference with the top of ornate, oversized window frames, pipes, vent covers, or crown moldings. The overall height of the lowered ceiling should conform with building code clearances.

All screws for furring channels or strips must penetrate into the ceiling joists prior to installation of the drywall. On occasion, some multi-family housing or commercial buildings converted to residential use may have cast-in-place, reinforced concrete ceilings. Anchoring supports for the new ceiling may not be practical in these instances. Though this construction is generally very strong, a structural engineer should be consulted about attaching a drywall system to the concrete. Onsite architectural or engineering advice is needed on a case-by-case basis to determine if this approach is appropriate.

Acoustical lay-in panels (drop-in ceilings) do not constitute lead-based paint enclosures, since

they will not adequately guard against the escape of leaded dust into the living space and cannot be sealed.

### 4. Floors

Lead-based painted floors should be enclosed with 1/2-inch or thicker plywood or other underlayment. The joints in underlayment should be flash patched. Shoe molding running along the baseboard should be removed before plywood installation and reinstalled when the finished floor is completely in place. If the shoe molding contains lead-based paint, new shoe molding should be installed, since new molding is inexpensive and more cost-effective than removing the paint from the old shoe molding. This will ensure that all floor covering runs tight to the baseboard and the joints at vertical surfaces are covered by the quarter-round molding. The plywood should be covered with vinyl tile or sheet goods to provide a cleanable surface. Covering the plywood with wall-to-wall carpeting is generally not recommended because the carpet does not provide a sealed top cover and is harder to clean. Vinyl floor coverings should be finished off with a metal threshold at all doorways or at any access to an uncovered open floor to protect the exposed edge.

When placing tile over old flooring, a row of nails (preferably screws) should be run a few inches apart in a straight line over each joist before putting down the plywood. Old floor nails often lose much of their grip, which results in squeaky floor boards. This movement can in turn cause the edges of floor tile to lift in spite of the plywood underlayment that was installed. It is most important to remember that all the plywood sheets must be installed flush with each other. Gaps must be filled with flash patching cement. Also, a bead of caulk should be run at the edge of every board before it is set in place. All nails must be hammered flush and all dirt HEPA vacuumed thoroughly; otherwise small lumps will eventually appear in the soft vinyl finish goods.

If the floor to be enclosed is poured slab or cast-in-place concrete, the surface will have to be predrilled to accept each screw that anchors the

plywood enclosure. A structural engineer should be consulted for situations other than slab on grade construction. Floor adhesive can offer an added measure of reinforcement and sealant. Each screwhead should be just below the level of the underlayment top surface and, along with the seams, should be covered with a smooth coat of flash patching cement to prevent dimples in the vinyl top cover.

## 5. Stairs

Dirt and loose paint should be removed prior to enclosure. Defective paint should be wet scraped and HEPA vacuumed, protective gear should be worn by the workers, and the work area should be contained with 6-mil plastic (or equivalent). In multifamily housing, common stairways must be accessible to residents and workers during the construction work to avoid a fire code violation.

Wooden steps with lead-based paint should be completely covered with vinyl or rubber treads and risers. These materials should have a minimum specification that would qualify for Federal Housing Administration (FHA) product approval or should be commercial grade. The vinyl should be stapled as well as glued with floor adhesive in order to avoid sagging. Long staples are preferred to reinforce the tread cover at this critical point and prevent the vinyl from being pulled up by the toe of a shoe. Metal bull nosing can also be used at this wear point.

In addition, long staples or metal bull nosing should be used at the end of the vinyl that butts up tight to the wood riser of the next step.

Plywood can be used to cover step risers and squared-off treads. Plywood is also useful as additional protection, supplementing the vinyl covers mentioned above. Precast concrete steps will have to be drilled, screwed, and glued to anchor the covers in place.

## 6. Pipes

Painted pipes can be enclosed with the same tape used to make plaster casts, which provides a hard-finished end product. Loose paint and dirt should be safely removed first. The wrapped

tape should overlap itself so that it is not dependent on adhering to the painted surface.

Pipes can also be enclosed with drywall. However, this type of enclosure will insulate and limit the ability of radiator pipes carrying steam or hot water to contribute to household heating.

## 7. Door Frames

Preformed metal door buck or frame covers come in standard sizes to accommodate most components, and as such they can be used to enclose both wood and metal door frames, either interior or exterior. All seams must be caulked. Primers on such bucks should be lead free.

## 8. Plywood Enclosures

Knee walls, painted structural supports, and trim such as baseboards, skirt boards, and stringers can be enclosed with plywood that is cut to fit tightly. These items should be sealed with adhesive and nailed. All joints should be caulked.

## E. Exterior Enclosure Systems

### 1. Siding

Vinyl or aluminum siding may be used to enclose painted exterior surfaces. In addition, porch columns (both square and round) and porch ceilings can be enclosed with these materials. Aluminum coil stock can be used on soffits, fascia, barge board, decorative crown moldings (though original detailing will be lost), door and window frames, parapets, and other moldings. All seams need to be caulked and back-caulked. Soffit coverings under roof areas often need to be vented to prevent dry rot. However, as old paint degrades behind this covering, a small amount may migrate through the vents. Breathable cloth materials such as Tyvek® or an equivalent are available in rolls for this purpose and can be installed prior to the aluminum covering (see Figure 12.10a). Tyvek® will help prevent leaded dust from escaping through gaps in the new siding, although it will be necessary to leave attic vents uncovered to

Figure 12.11 Seal All Seams for Enclosure.

**Create a dust-tight seal**

Paint deteriorates more quickly behind an enclosure. All edges of an enclosure—especially the bottom—must be sealed well.

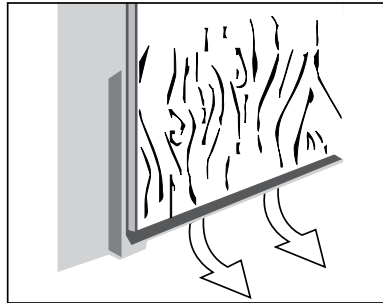
**Seal the bottom edge**

- ◆ Caulk the enclosure material at the bottom.
- ◆ Back-caulk and nail the baseboard in place.
- ◆ Back-caulk, bottom-caulk, and nail the shoe molding in place.

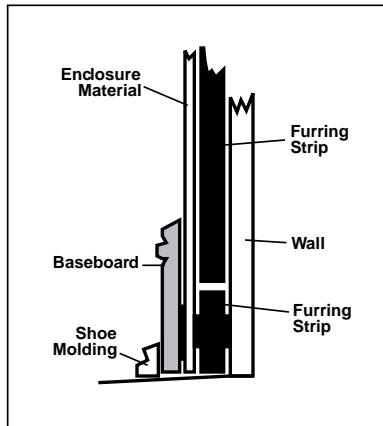
**Seal the seams and other edges**

- ◆ Back-caulk all the seams that aren't taped and spackled. Use a high quality adhesive caulk.
- ◆ Use a "J-channel" where drywall meets a finished surface. A J-channel is a final strip attached to the rough edge of drywall to make a finished edge. It's called a "J-channel" because of its shape. Caulk the outside edge so it seals with the finished surface. Screw the drywall in place.

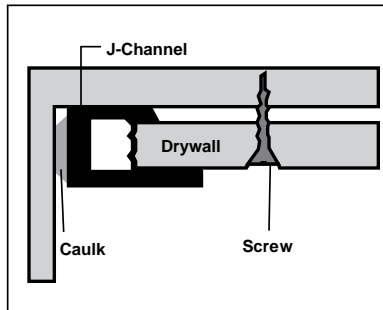

permit adequate ventilation. Vent openings should not be covered with Tyvek® or other similar covering.

Since siding may not provide an airtight enclosure, rigid or flexible dust barriers like Tyvek® should be installed before broad surface enclosure. Perforated metal stock should not be used to enclose soffits, fascia, or eaves, since the enclosure is not dust tight.

Rotten or loose wood and any other defective substrate must be repaired or replaced

to provide a sturdy foundation for the siding installation and edges.

**2. Windows**

For standard-sized windows, snap-in replaceable aluminum and vinyl tracks are available. These devices help eliminate the painted friction point (and thus the generation of leaded dust) where the moving sash abrades the painted surface. The track covers should be pressed into a bead of caulk at each joint. Painted sashes should be planed to remove lead-based paint

and then reinstalled (see Chapter 11, Section III). Friction surfaces on windows should not be painted.

Window troughs should be covered with fitted metal and screwed into place. Again, the metal should be pressed into a bead of caulk at the joints and edges.

### 3. Exterior Walls

Board products made of various materials (e.g., synthetic fiberboard, wood byproduct composites, and cementitious materials) are commonly used in the construction industry for exterior purposes. These heavy, sometimes brittle coverings often have resins, fiberglass, or other durable ingredients that make them resistant to weathering and may require little maintenance, including painting. An added benefit of using these products is that they may have thermal insulation value. The products are best installed over flat surfaces that are not soft, crumbling, unstable, or otherwise defective. A defective substrate must be repaired prior to enclosure. All joints need to be sealed after installation.

Properly installed, natural or synthetic brick and stone veneers can be used to enclose exterior walls. In addition, stucco can be used as a covering material using wire mesh to physically anchor the cement to solid building components. A defective, weak surface needs to be

stabilized before covering. Vinyl and aluminum siding are usually the least expensive options.

### F. Summary

Enclosures are solid materials that are physically anchored to building components and that cover lead-based paint. Enclosure usually involves common construction techniques and has a 20-year design life. The enclosure abatement option is an effective, stable remedy for minimizing the danger of lead-based paint exposure. Because any barrier can be breached, annual monitoring by the owner and reevaluation by a certified risk assessor or inspector technician, are necessary.

Enclosure may be less hazardous and cheaper than paint and building component removal. There is less dust generated and little hazardous waste disposal. Unlike encapsulation, the enclosure is not dependent on the adhesion of the underlying coats of paint on the substrate surface for its durability, nor does it require deteriorated paint removal or surface cleaning and deglossing before installation.

Drywall is often a cost-effective interior finish, and aluminum or vinyl siding provides an acceptable exterior barrier. Aluminum coil stock is effective for enclosing outside trim. Floors require underlayment and vinyl or other sheet finish goods. Vinyl or rubber tread and riser coverings are recommended for steps.



# Paint Removal: How To Do It

1. Do not use prohibited paint removal methods:
  - ◆ Open flame burning or torching.
  - ◆ Heat guns operating above 1,100 °F.
  - ◆ Machine sanding or grinding without a HEPA vacuum exhaust tool.
  - ◆ Uncontained hydroblasting or high-pressure wash.
  - ◆ Abrasive blasting or sandblasting without a HEPA vacuum exhaust tool.
2. Avoid using the following methods:
  - ◆ Methylene chloride chemical paint removers.
  - ◆ Dry scraping (except for limited areas).
3. Select the appropriate Worksite Preparation Level (see Chapter 8).
4. For heat gun work, provide fire extinguishers in the work area and ensure that adequate electrical power is available. Use for limited areas only. Train workers to avoid gouging or abrading the substrate.
5. For mechanical removal methods, use tools equipped with HEPA exhaust capability. Be sure workers keep the shroud against the surface being treated. Vacuum blasting and needle guns should not be used on wood, plaster, drywall, or other soft substrates. Observe the manufacturer's directions for the amount of vacuum airflow required.
6. For wet scraping, use a spray bottle or wet sponge attached to the scraper to keep the surface wet while scraping. Apply enough water to moisten the surface completely, but not so much that large amounts run onto the floor or ground. Do not moisten areas near electrical circuits.
7. For chemical paint removers, determine if the building component can be removed and stripped offsite. Offsite stripping is generally preferred to onsite paint removal. Observe all manufacturer's directions for use of paint removers.
8. For offsite stripping, determine how to remove the component. Score the edges with a knife or razor blade to minimize damage to adjacent surfaces. Punch or tag the building component if similar building components are also being stripped offsite (e.g., doors). This will ensure that the individual component is reinstalled in the same location. Inform the offsite paint remover that lead-based paint is present before shipping. Wrap the component in plastic and send to the offsite stripping location. Clean all surfaces before reinstallation to remove any lead residues by HEPA vacuuming all surfaces, cleaning with other lead-specific cleaners, or phosphate detergents, and HEPA vacuuming again. Conduct cleanup and clearance.



9. For onsite paint removal, first test the product on a small area to determine its effectiveness. Chemical paint removers may not be effective or desirable on exterior, deteriorated wood surfaces, aluminum, and glass. Provide neoprene, nitrile, rubber, or polyvinyl chloride (PVC) gloves (or other type of glove recommended by the manufacturer); face shields; respirators with combination filter cartridges for leaded dust and organic vapors (if appropriate); and chemically resistant clothing. Be sure to select the right type of organic vapor filter cartridge, gloves, and clothing for the specific chemical being used. Portable eyewash stations capable of providing a 15-minute flow must be onsite. Apply the chemical and wait the required period of time. Maintain security overnight to prevent passersby from coming into contact with the chemical. For caustic chemical paint removers, neutralize the surface before repainting using glacial acetic acid (not vinegar). Repaint and conduct cleanup and clearance.
10. Dispose of waste properly; most wastes from paint removal projects, such as paint chips and paint remover sludges, will need to be managed as hazardous waste.
11. Conduct cleanup.
12. Have a certified risk assessor or inspector technician conduct a clearance examination and provide documentation and a Statement of Lead-Based Paint Compliance.



## Section IV

### I. Paint Removal Methods

#### A. Introduction

“Paint removal” means the separation of the paint from the substrate using heat guns, chemicals, or certain contained abrasive measures, either onsite or offsite. As an abatement technique, paint removal is usually reserved for limited areas and for those surfaces where historic preservation requirements may apply.

While paint removal can be performed safely and effectively, it also demands the highest level of control and worker protection for several reasons. Paint removal usually creates the greatest hazard for the worker, either from the hazards associated with the removal process (e.g., heat, chemicals, and sharp tools) or from the lead that becomes airborne or is left as a residue on the surface after removal. Extensive onsite paint removal should usually have an Interior Worksite Preparation Level 4 and an Exterior Worksite Preparation Level 3. Lower levels are possible if the size of the area to be treated is small (see Chapter 8). Because of the lead residues left behind by all paint removal methods, particularly on porous surfaces such as wood or masonry, more extensive cleaning is usually required to meet clearance criteria. Paint removal methods also generate a significant amount of hazardous waste and may be the most costly of all lead abatement methods (HUD, 1991).

In spite of these limitations, paint removal has the benefit of a low reevaluation failure rate. If some lead-based paint is left in the dwelling, its condition will need to be monitored by the owner and by a certified risk assessor based on the Reevaluation Schedule for the specific property (see Chapter 6).

#### B. Prohibited Methods

Certain methods of lead-based paint removal are absolutely prohibited, either because of unacceptably high worker exposures to lead

or release of lead into the environment through production of dust or fumes or both.

#### 1. Open Flame Burning or Torching

Burning, torching, fossil fuel-powered heat plates, welding, cutting torches, and heat guns operating at temperatures greater than 1,100 °F are prohibited as a means of paint removal because of the high temperatures generated in the process. So-called heat plates (those using propane to heat a grid, which in turn heats the paint) are also prohibited because of the high temperatures generated. At these temperatures, lead fumes may be produced.

Lead fumes are formed when lead is heated into a gas. The gas cools when it comes into contact with the cooler surrounding air and condenses into very small particles. These particles travel easily, are readily inhaled and absorbed into the body, and are difficult to clean up. Several researchers have found that worker exposures are extraordinarily high when doing this kind of work (NIOSH, 1992a; Jacobs, 1991b; Rekus, 1988). The fumes may also travel throughout the dwelling, contaminating all surfaces with which they come into contact. Other hazardous substances may be released from the paint film using heat.

Using cutting torches to remove fire escapes, railings, or other metal components coated with lead-based paint is also prohibited unless the paint is removed first. Similarly, welding of painted metal components (such as preprimed structural steel) is prohibited by Occupational Safety and Health Administration (OSHA) regulations (29 CFR 1926.354(d)).

#### 2. Machine Sanding or Grinding Without a HEPA Exhaust Tool

Machine sanding or grinding is prohibited (regardless of the grit used) because of the large volume of leaded dust generated. As a result of these methods, workers have been exposed to extremely high leaded dust levels, and blood lead levels in resident children have increased (Amitai, 1991; Farfel, 1990; Jacobs, 1991b). However, machine sanding with a HEPA



Figure 12.12a Open Flame Burning Is Prohibited.



Figure 12.12b Open-Faced Power Sanding or Grinding Is Prohibited.

exhaust tool is permitted and is discussed further below. Extensive dry hand sanding is not recommended, but wet sanding can be done if no electrical outlets are nearby. Limited dry sanding or scraping near electrical circuits is permitted.

### 3. Uncontained Hydroblasting or High-Pressure Water Wash

Uncontained hydroblasting and high-pressure water washing are prohibited. Because of the potential for widespread environmental contamination, such activities should be undertaken with full containment. All water should be captured, contained, and treated as potentially hazardous waste (contact the local water and sewage agency for guidance on local requirements). Since capturing and containing *all* water is not feasible, this method of paint removal is not permitted for lead-based paint abatement work in housing.

### 4. Abrasive Blasting or Sandblasting

Traditional abrasive blasting or sandblasting is prohibited in residential structures, regardless of whether the abrasive material is recycled or if the area is fully contained. These methods produce widespread dust contamination; full containment is nearly impossible to maintain and guarantee in a residential environment. Abrasive blasting should only be carried out using HEPA vacuum local exhaust equipment, which is discussed below.

If for some reason abrasive blasting must be done in a residential structure, the area must be sealed and placed under negative pressure with at least 10 air changes per hour. If the exterior must be blasted, the entire building must be covered with a tent and placed under negative pressure with at least 10 air changes per hour. In both cases, all exhaust air must be passed through a HEPA filter. Fresh air should be provided to the containment zone at a lower rate than the exhaust airflow to maintain the negative pressure zone.

## C. Methods Not Recommended

### 1. Dry Scraping

Dry scraping is not recommended because of the large volume of particulate matter that is generated (including high levels of leaded dust).

The two situations where dry scraping is appropriate include scraping surfaces near electrical outlets, which cannot be wet scraped because of the obvious electrocution hazard, and scraping when using a heat gun since this cannot be performed wet. For both of these cases, dry scraping is only appropriate for limited surface areas.

### 2. Chemical Paint Removers Containing Methylene Chloride

Chemical paint removers containing methylene chloride are not recommended, although they are still widely sold in paint stores. This also applies to methylene chloride paint removers that have waxes or other coatings to retard evaporation. Some local regulations may prohibit the use of methylene chloride. Since methylene chloride evaporates readily and is colorless and odorless at the permissible exposure limit, workers may be unaware of their exposure. Methylene chloride can cause liver and kidney damage and carbon monoxide poisoning (as a metabolite) and is suspected to cause cancer (ACGIH, 1992; IARC, 1990). Air-purifying respirators with organic vapor cartridges *do not provide adequate protection* against methylene chloride. In those projects where methylene chloride must be used, air-supplied respirators (or self-contained breathing apparatuses) are required under OSHA regulations (29 CFR 1910.134).

## D. Recommended Methods

### 1. Heat Guns

Since open flame burning is prohibited, heat removal methods are limited to electric-powered flameless heat guns.

Before beginning work, fuses and an adequate electrical supply should be verified. Larger fuses should not be installed because of the possibility



Figure 12.13 Traditional Abrasive Blasting Is Prohibited (note the visible dust surrounding the worker).



Figure 12.14 Do Not Wet Painted Surfaces Near Electrical Circuits.



Figure 12.15 Heat Guns Operating Below 1,100 °F Are Useful for Limited Areas.

of creating a fire hazard. A portable electric generator may be needed, especially if several heat guns will be required. Care should be exercised around wallpaper, insulation, and other flammable materials. An accessible garden hose with a pressure-release spray nozzle, a crowbar to remove smoldering wood, and a long-handled sledgehammer to open up walls exposed to smoldering insulation should be readily available. Under OSHA regulations (29 CFR 1926.150), a fully charged ABC-type 20-pound (minimum) fire extinguisher must be available within 100 feet of the work area. Work should be conducted only in well-ventilated spaces, since other hazardous materials may be released when heating old painted surfaces (NIOSH, 1990).

While there is little danger of producing dangerous levels of lead fumes at temperatures below 1,100 °F, significant airborne particulate lead is generated by the accompanying scraping of the paint. Also, significant amounts of potentially harmful organic vapors can be released from the action of the heat upon the paint, even at temperatures below 1,100 °F. For this reason, air-purifying respirators should be outfitted with both a HEPA-filtered cartridge and an organic vapor cartridge. Organic vapor cartridges may not be available for some powered air-purifying respirators.

Depending on the size of the area and the substrate, paint removal by heat gun can be a slow, labor-intensive process and may result in a high final clearance failure rate if used extensively and without proper cleanup. Removing paint completely, particularly from crevices, requires attention to detail. Significant leaded residue may remain on surfaces unless cleanup is thorough. Heat guns do not appear to be particularly effective on metal or masonry substrates, which are too porous to be scraped effectively; the heat may cause small particles to fly up and hit the worker, causing burns or eye damage. Although heat guns work well on wood, they will usually damage drywall and plaster.

Workers may tend to place the nozzle of the heat gun too close to the surface, burning out the heating elements prematurely. One way to prevent this is to attach a small metal wire cage or extension tube to the end of the heat gun to prevent it from being placed too close. For most heat guns, the optimal distance from the surface is 3 to 6 inches. The heat gun is recommended only for limited surface areas in well-ventilated spaces. Other problems with heat guns include additional fire hazards from dry rot, insulation, and dust, especially in window troughs, roof areas, and hollow porch columns. Scraping often leaves the substrate very rough and may singe adjacent wallpaper. Telephone wires mounted on baseboards can melt, and heat can crack glass with a cold exterior or dry glazing.

To use heat guns properly, allow the heat stream leaving the gun to merely soften the paint. Do

not allow the paint film to scorch or smoke. At the very first sign of paint softening, blistering, or bubbling, discontinue the use of heat and immediately scrape the loose paint off the surface.

## 2. Mechanical Removal Methods

### *HEPA Sanding*

HEPA sanders are valuable for surface preparation prior to repainting. Since chemical stripping sometimes raises the grain of the wood and some removal methods are not effective at removing all visible traces of paint, some sanding prior to repainting may be needed. Sanding can cause generation of significant levels of airborne and settled lead dust; therefore, HEPA-assisted sanders are recommended whenever sanding must be done. HEPA sanders do not work well on detailed moldings.

HEPA sanding uses traditional electric sanders, such as disc sanders or orbital or vibrating sanders, equipped with specially designed shrouds or containment systems that are placed under a partial vacuum (also known as local exhaust ventilation). All exhaust air is passed through a HEPA filter (often using an ordinary HEPA vacuum) to reduce the amount of airborne particulate lead. The HEPA vacuum must be correctly sized to provide adequate airflow to permit the system to operate properly. If hoses are longer than normal, a larger HEPA vacuum may be needed to handle the increased pressure drop.

There are two main types of HEPA sanders. The first uses a flexible shroud to surround the sanding head, with the HEPA vacuum hose attached to the shroud. The shroud must be in constant contact with the surface to be effective. If the shroud extends beyond the surface being sanded, large amounts of particulate lead will be released into the air. In addition, this configuration makes it impossible to sand to the edge of protruding surfaces, such as baseboards or window and door casings.

The second type of HEPA sander pierces the sandpaper with holes through which the vacuum draws the dust. This allows the

Figure 12.16 HEPA Vacuum Power Tools.

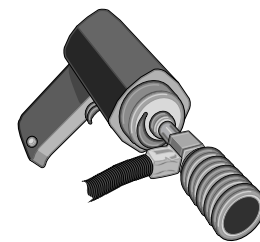
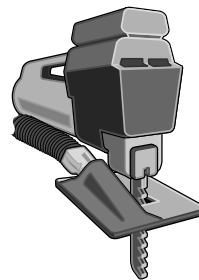
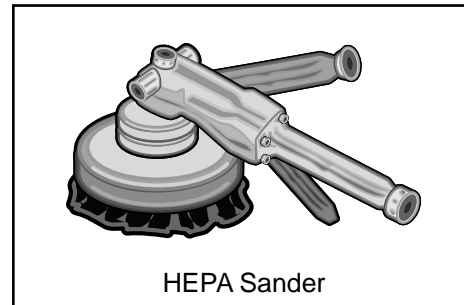

instrument to be used to the edge of protruding surfaces. However, care must be exercised to keep the sandpaper flat on the surface. Neither one of these methods is completely effective; respirators are always recommended. Worker fatigue can also prevent the worker from holding the tool flush with the surface, making it necessary to provide frequent breaks or rotate workers.

### *Wet Scraping*

Wet scraping is feasible on most surfaces and results in lower lead exposures than dry scraping. Since surfaces near electrical outlets should never be moistened (due to the electrocution hazard), these areas should be dry scraped.

Wet scraping can be performed by using a spray bottle or sponge attached to a paint scraper. Wet scraping is often used to remove loose and

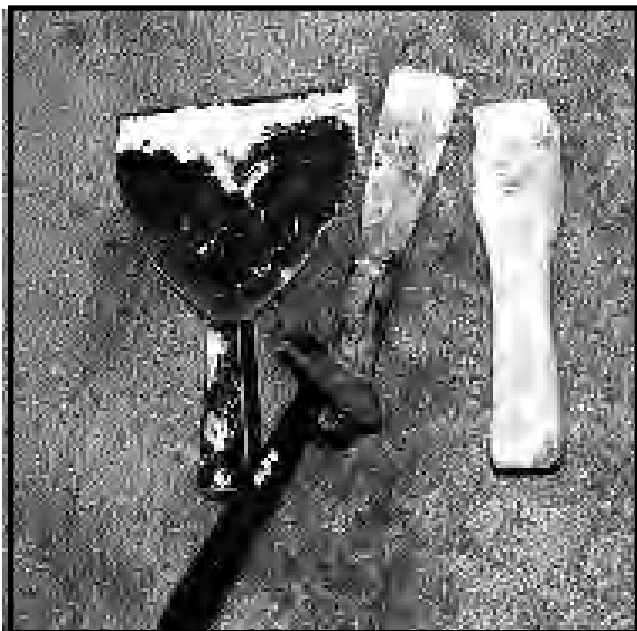

Figure 12.17 Scraping Tools.



Figure 12.18 Vacuum Blasting.

flaking paint prior to paint film stabilization or encapsulation. If wet scraping is employed as an abatement technique, a more durable covering than new paint is needed.

Working a few square feet at a time, the surface should be lightly misted with water from a garden sprayer or plant mister. Using a paint scraper, loose material should be scraped from the surface and deposited on the containment plastic. Damp paint chips should be cleaned up as soon as possible so that they are not tracked throughout the work area or crushed beneath the feet of workers.

Scraper blades should be kept sharp to minimize abrasion and gouging. Additional scraper blades should be on hand and should be selected for the type of surface being scraped. To obtain a smooth finish, it may be necessary to follow wet scraping with wet sanding. A variety of scraping tools are available from hardware and paint supply stores.

#### *HEPA Vacuum Blasting*

HEPA vacuum blasting is simply abrasive blasting with a shroud under a vacuum that is attached to the blast head. All exhaust air is passed through a HEPA filter, using a properly sized HEPA vacuum system. Vacuum blasting is appropriate for metal, brick, concrete, and other masonry surfaces. To date, attempts to use the process on wood, plaster, and other soft materials have not been successful, as they usually cause severe substrate damage.

Various blasting media can be used (e.g., aluminum oxide, metal shot, walnut shells) depending on the type of substrate. Blast heads, usually a brush-type arrangement, come in various sizes and shapes. The blast head must remain in continuous contact with the surface to avoid dispersal of both the blast medium and particulate lead. The equipment can be outfitted with a device that separates the blast media from the paint, effectively recycling the blast material, and dramatically reducing the volume of waste.

This is particularly important, since the blast material will probably be treated as hazardous waste.

Use of the equipment for long periods of time can result in worker fatigue, particularly if working with the arms above the head. Since fatigue can cause a worker to momentarily lose contact with the surface, resulting in the release of leaded dust, the goal is to minimize the degree to which workers must reach above their shoulders. Scaffolding and platforms should be constructed to minimize such stress and frequent work breaks should be taken. Vacuum blasting is not typically used in interior residential work.

### HEPA Vacuum Needle Gun

The HEPA vacuum needle gun is similar to vacuum blasting in concept but avoids the use of a blast medium. In the vacuum needle gun, metal needles rapidly pound against the painted surface, dislodging the paint. The HEPA vacuum, which is connected to the gun head, draws paint chips and dust into the vacuum, minimizing the dispersion of the particulate.

The needle gun is appropriate for metal surfaces but may cause significant damage to masonry. Problems of worker fatigue are similar to those encountered in vacuum blasting. Losing shroud contact with the surface can cause the deposition of significant amounts of chips onto the containment surface. Chips should be cleaned up as soon as possible following the work to avoid tracking.

One way of maintaining the seal with the surface is to select the proper shroud for the shape of the surface treated. At least one manufacturer (Penntek) has developed different shrouds for corners, edges, and flat surfaces. Needle guns are not effective in capturing large paint chips, so use of plastic sheeting underneath is required.

### 3. Chemical Removal Methods

Chemical removal may result in less leaded dust generation than other removal methods. It is often used in situations where historic preservation requirements apply. However, it may leave leaded residues on porous surfaces, which may pose a hazard to resident children in the future.

One study has demonstrated that windows treated with chemical paint removers had high leaded dust levels a few months after treatment, even though cleanup and clearance had been conducted properly (Farfel, 1992).

Other drawbacks to chemical removal include high cost and potential harm to workers from splashes and chemical burns if proper gloves, face shields, and clothing are not provided. Proper ventilation is necessary when using chemical paint removal. Plastic may not be effective in protecting floors and may have to be augmented by paper or cardboard. Chemical residues can be tracked into other areas on workers' shoes if proper decontamination is not conducted. Adjacent surfaces, especially plaster, can also be damaged. High humidity may retard the chemical remover's effectiveness. If protective clothing is penetrated and becomes matted against the skin, it must be removed *immediately*. A full shower is strongly



Figure 12.19a. Needle Gun With HEPA Exhaust Ventilation (without shroud).



Figure 12.19b. Needle Gun With HEPA Exhaust Ventilation (with shroud).



Figure 12.20 Proper Protective Gear, Including Gloves, Faceshield, Goggles, and Eyewash is Required When Working With Chemical Paint Removers.



Figure 12.21 Use Punches To Identify the Location of Components Before Sending Them Offsite for Paint Removal.

recommended; the skin must be washed and thoroughly rinsed.

Chemical paint removal can be broken into two broad categories: offsite paint removal and onsite paint removal.

### Offsite Paint Removal

Offsite paint removal is preferred, since most of the contamination and residues are generated away from the dwelling. The general approach is as follows.

Building components to be stripped must first be removed from the building. Misting with water prior to removal will help minimize the amount of airborne lead. The painted seam between the component and the wall should first be cut with a utility razor knife to minimize damage to the adjacent plaster. If there is more than one similar component, they should be labeled using a punch system in an obscure location (e.g., the bottom or side of a door), then wrapped in plastic and sealed with tape to avoid the spread of contamination during transport. Tag systems are not recommended since they must be removed when the component is dipped. Markers should not be used since they will dissolve during stripping. The punch will identify exactly where the component came from, eliminating the need for changing doors or other retrofitting problems.

Potential damage to components during stripping includes damage to hardware (this should be removed before stripping), broken glass, loss of glue joints and fillers, damage to wood fibers (wood swelling), and raising of the wood grain. The component may even fall apart and have to be blocked and reglued. Old glazing compounds on windows may also be weakened. The stripping firm should be instructed to *thoroughly* wash and neutralize the components after stripping.

Before materials are returned from the paint stripper, they should be wrapped in 6-mil plastic and sealed with tape. This will minimize contamination of those handling the materials since leaded residue may remain on the surface. Materials should remain sealed in plastic until other onsite dust-generating activities are concluded and the dust cleaned up.

Before reinstallation, the treated components should be cleaned using the standard HEPA/wet wash/HEPA cycle to remove any residues left by the paint stripper. Components must be

completely dry before repainting. Always check the pH after cleaning and *before* repainting.

### Onsite Paint Removal

Many paint removers must be allowed to remain on the surface anywhere from 1 hour to a day or more to accomplish effective stripping. Most paint removers are efficient within a limited temperature range and may be completely ineffective in cold weather. The contractor must therefore be certain of weather conditions prior to outdoor application. Also, rain can cause environmental contamination from the lead and the chemical remover.

Paint removers are either caustic or noncaustic. The noncaustic chemical removers are generally safer to use than the caustic ones (assuming the former do not contain methylene chloride). Material Safety Data Sheets should always be consulted to determine potential chemical hazards.

When using chemical strippers, security is important, particularly with the caustics. Caustic paint removers can cause severe skin burn and eye damage to workers and children who may gain access to the work area. Pain receptors in the eyes are not as sensitive to caustic substances as they are to acids, so workers may suffer damage without immediately realizing it.

The use of chemically resistant clothing; long neoprene, nitrile, rubber, or PVC gloves; and face shields is mandatory under OSHA regulations. OSHA also requires a portable eyewash station whenever eye-irritating paint removers are used in housing.

An abundant source of running water in the abatement area for flushing chemicals from skin or eyes is required by OSHA regulations. The water should come from a nearby tap or portable eyewash stations. If contact with the eyes occurs, a full 15-minute rinse of the eyes is necessary onsite, *before the individual leaves to seek medical attention*, since permanent damage to the eyes occurs quickly. While 15 minutes may seem excessive, a quick rinse is ineffective, and permanent damage usually occurs on the way to seek medical attention.

Usually, noncaustic strippers are not as effective at removing multiple layers of paint in a single application, compared to the caustic products. When using noncaustic removers, small areas should be tested before full-scale treatment to determine their efficacy. For vertical surfaces, adhesion of the liquid or gel-type paint removers should also be tested to determine runoff potential (particularly a problem in warm weather). Most caustic paint removers work best on nonporous surfaces such as steel. They generally should not be used on aluminum or glass surfaces.

Paint removers that contain volatile substances should be used only in areas equipped with mechanical ventilation and only when workers are properly equipped with gloves, face shields, protective clothing, and respirators, as needed.



Figure 12.22 Eye Wash Stations Are Required When Caustic or Chemical Paint Removers Are Used.



Figure 12.23a Neutralize Surfaces When Using Caustic Paint Removers.



Figure 12.23b Neutralize Surfaces With a Glacial Acetic Acid Wash When Using Caustic Paint Removers.

The paint remover should be applied with a spatula, trowel, brush, or spray gun. Spray gun use should be minimized since worker exposures are greater. The time the remover must stay on the surface will depend upon the number of layers of paint, the type of paint, the temperature, and the humidity, and can range from a few hours to a day or more. The paint remover should not be allowed to dry out. Some manufacturers provide a polyethylene or paper blanket that is pressed into the surface to retard drying; others contain a film that is formed on the surface of the paint remover as it sits to prevent drying. Caution must be used when applying the paint remover overhead in order to avoid dripping onto workers below.

After the appropriate period of time, the softened paint should be removed using a scraper or putty knife and the material deposited in a watertight and corrosion-proof container (usually supplied by the manufacturer). The waste should be submitted for "Toxicity Characteristic Leaching Procedure" (TCLP) tests to determine if it qualifies as hazardous waste. Alternatively, the owner can assume that it is hazardous waste and manage it accordingly (see Chapter 10). Chemical stripper waste is almost always hazardous waste. The stripped surface must be thoroughly cleaned to remove lead and paint remover residues.

With wood surfaces, it is important to complete the entire neutralization and cleaning process without letting the surface dry. If the wood dries before cleanup is complete, the pores in the wood may close, locking potentially significant leaded residues inside. When repainting, some of the leaded residue may leach into the new paint.

Alkali neutralization and residue removal are accomplished as follows. Immediately after paint removal (while wood surfaces are still damp), the surface should be thoroughly scrubbed with a solution of glacial acetic acid. Use of vinegar to neutralize the alkali should be avoided since vinegar may be inadequate as a neutralizing agent and will also result in a significantly larger volume of liquid (and potentially hazardous) waste.

Glacial acetic acid is hazardous and can cause skin burns and eye damage. It should be used carefully and only with neoprene, nitrile, rubber, or PVC gloves; chemically resistant clothing; eye shields; a NIOSH-approved acid gas cartridge; and a HEPA filter on air-purifying respirators.

The damp, stripped surface should be thoroughly scrubbed with the acetic acid solution. The solution should be monitored with pH litmus paper and discarded if the pH exceeds 6. After use, the solution should be placed in corrosion-proof containers and treated as potentially hazardous waste. Sponges and other cleaning materials should not be reused but deposited

in double 4-mil or single 6-mil trash bags that are sealed, labeled, and put in a secure waste storage area.

Following neutralization, the damp surface should be thoroughly scrubbed with a high-phosphate detergent or other cleaner. Scrubbing should continue until no residues are visible. The cleaning solution should be changed when it becomes dirty. Following the detergent scrub, a clean water wash should be performed to remove residue. The pH of the water wash should be checked after use. If the pH exceeds 8, further neutralization of the surface with the acetic acid solution is necessary prior to repainting since an alkaline surface will cause the new paint to fail in a matter of days or weeks.

Surfaces should be completely dry before repainting. For wood surfaces, this may take several days to a week. If the moisture has raised the grain and sanding of wood surfaces is required before repainting, a HEPA sander should be used.

Since porous surfaces such as wood or masonry may still have slight alkali residues, some types of oil paints should not be used after caustic paint remover application. To do so may result in saponification (a “soap-making” reaction between the paint and the substrate, leading to rapid paint failure). Therefore, latex paints are probably most appropriate. Wood surfaces (especially exterior ones) can deteriorate after paint removers have been applied, making new paint difficult to apply. Also, the new paint may not last long on deteriorated substrates. Some old plasters with a high pH may require special primers, which are no longer manufactured. A special sealant may be needed on such surfaces. The specific paint remover manufacturer should be contacted for further guidance on appropriate paints to use.

High-pressure water removal of caustic paint removers should be avoided since control of solid and liquid contamination is difficult. Release of solids or liquids into the soil is likely to result in costly cleanup. Care must be used when applying caustic paint removers to friction surfaces, such as window jambs. Such surfaces are often weathered, making residue removal even more difficult. If these residues are embedded in a coat of new paint, the friction caused by opening and closing the windows can lead to the release of leaded dust.

### E. Waste Disposal

Wastes produced during paint removal are highly concentrated, but low in volume. The waste may be exempt from some hazardous waste regulations if less than 220 pounds is generated per month (see Chapter 10). Many local jurisdictions pick up small amounts of hazardous waste on certain days. If offsite paint removal is performed, the waste is the responsibility of the facility performing the removal.



Figure 12.24 Use Litmus Paper on a Bare Stripped Surface Before Repainting.





## Soil and Exterior Dust Abatement: How To Do It

1. Determine if a soil lead hazard exists. For a hazard to exist, a total of at least 9 square feet of soil in a single yard or area must be bare and soil concentrations must exceed either 2,000  $\mu\text{g/g}$  of lead for the yard or building perimeter or 400  $\mu\text{g/g}$  of lead for small, high-contact play areas (pending the development of an EPA soil standard). Bare soil above these levels should be treated by either interim controls or abatement. Soil abatement is most appropriate when levels of lead are extraordinarily high (greater than 5,000  $\mu\text{g/g}$ ) and when use patterns indicate contact frequency and exposure will be high.
2. Collect preabatement soil samples to determine baseline levels. These samples need not be analyzed if postabatement soil samples are below applicable clearance levels.
3. Determine the method of soil abatement (soil removal and replacement, soil cleaning, or paving). Soil cultivation (rototilling or turning over the soil) is not recommended.
4. If paving, use a high-quality concrete or asphalt. Observe normal precautions associated with traffic load weight and thermal expansion and contraction. Obtain any necessary permits. Keep soil cultivation to a minimum.
5. If removing and replacing soil:
  - a. Determine if waste soil will be placed in an onsite or offsite burial pit. Prepare vehicle operation and soil movement plan. Test new replacement soil (should not contain more than 200  $\mu\text{g/g}$  lead).
  - b. Contact the local United Utilities Protection Service (UUPS), Miss Dig, Miss Utility, or the American Public Works Association at (816) 472-6100, ext. 584, to determine location of underground utilities, including water, gas, electric, cable TV, and sewer, or contact each utility individually. Mark all locations to be avoided.
  - c. Remove fencing if necessary to allow equipment access and define site limits with temporary fencing, signs, or yellow caution tape.
  - d. Tie and protect existing trees, shrubs, and bushes.
  - e. Have enough tools to avoid handling clean soil with contaminated tools.
  - f. Remove soil.
  - g. Clean all walkways, driveways, and street areas near abatement area.
  - h. Replace soil at proper grade to allow drainage. Replacement soil should be at least 2 inches above existing grade to allow for settling.
  - i. Install new soil covering (grass or sod) and maintain it through the growing season.
  - j. Have enough workers and equipment available to complete the job in 1 day.



## Step-by-Step Summary (continued)



6. Determine if soil waste is hazardous and manage it accordingly (see Chapter 10).
7. Conduct final cleanup and clearance.
8. Provide walk-off doormats to residents and educate them on the benefits of removing shoes at the dwelling entryway.



## Section V

### I. Soil and Exterior Dust Abatement

#### A. Introduction

Lead-contaminated soil and exterior dust have been shown to cause elevations in blood lead levels of children in a number of studies (EPA, 1993c). Exposure to lead in soil and exterior dust can occur both outside during play and inside from soil and dust carried into houses on shoes, clothing, pets, or other means.

Soil can become contaminated over a period of years from the shedding of lead-based paint on nearby buildings, windblown leaded dust from adjacent areas, and fallout of leaded dust from the atmosphere (either from a local point source or from leaded gasoline emissions in the past). Uncontrolled paint removal from nearby houses or painted steel structures can also result in contaminated soil (controlling soil lead levels should be a consideration in every exterior lead-based paint abatement project).

Soil lead hazards are determined by measuring the concentration of lead in the soil, examining the location and use of the soil, and determining the degree to which the soil is "bare" (see Chapter 5). For a yard or area to require hazard control, a total of at least 9 square feet of bare soil must be present. Any size bare area in a play area containing more than 400  $\mu\text{g/g}$  of lead is a hazard. Appendix 13.3 contains details on a sampling method to measure lead in soil. When assessing the condition of the surface cover, it is important to determine why the soil is bare. Bare soil is common in the following areas and circumstances:

- ◆ Heavily used play areas.
- ◆ Pathways.
- ◆ Areas shaded by trees or buildings.
- ◆ Areas with damaged grass.
- ◆ Drought conditions.

Measuring the lead content of soil will aid in the selection of an appropriate abatement method that has a reasonable likelihood of being maintained. Soil *abatement* (as opposed to interim controls) is generally appropriate when lead is present in extraordinarily high concentrations (more than 5,000  $\mu\text{g/g}$ ), use patterns indicate exposures are likely, or interim controls are likely to be ineffective (e.g., planting grass in high-traffic areas). Soil interim controls were covered in Chapter 11, Section V. This section describes soil treatments that should be effective for at least 20 years.

Preabatement soil samples should be collected but not necessarily analyzed until postabatement soil samples have been collected, analyzed, and compared to clearance standards. If postabatement soil levels are below applicable limits, the preabatement samples need not be analyzed (see Chapter 15).

#### B. Soil Abatement Methods

Soil abatement methods include:

- ◆ Soil removal and replacement followed by offsite or onsite disposal.
- ◆ Soil cultivation (rototilling).
- ◆ Soil treatment and replacement.
- ◆ Paving with concrete or asphalt.

Soil removal is discussed in detail below; however, before choosing to remove contaminated soil, other treatment options should be considered. The advantages of using soil treatment methods (as opposed to soil removal) are threefold (Elias, 1988):

- ◆ The costs of hauling large quantities of contaminated soil are eliminated or greatly reduced.
- ◆ Disposal sites for soil are not needed except for a much smaller volume of wastes generated during the treatment process.
- ◆ The need for uncontaminated replacement soil is greatly reduced.

## 1. Soil Removal and Replacement

For most soil removal projects, removal of 6 inches of topsoil is adequate. The depth of soil lead contamination is usually restricted to the top of the soil, with contamination decreasing markedly below the top few inches. However, in urban areas it is not uncommon for the contamination to extend to up to 1 or 2 feet in depth. This may be because these areas were once the location of buildings contaminated with lead-based paint. Alternatively, past practices may have resulted in a gradual buildup of the elevation of the soil grade over time. In such circumstances, the removal of the top layer of soil may leave behind contaminated soil at lower depths. In mixed residential/industrial areas, or where industry once existed, the depth of the contamination may vary widely. The desired decision on the depth of removal should also consider the depth of soil disturbance during the course of usual activities, such as gardening. If the top layer of soil will not be penetrated, then it should not be necessary to remove lead-contaminated soil at deeper levels, since there will be no exposure.

In the EPA Urban Soil Lead Abatement Project (EPA, 1993c), the depth chosen for demonstration purposes was 6 inches. In residential areas in Canada, where secondary lead smelters are the primary source of contamination, soil also was removed to a depth of 6 inches (Stokes, 1988). Guidelines for soil removal developed by the Ontario Ministry of the Environment (1987) recommended removal of the top 12 inches. The 12-inch recommendation was based in part on earlier experiences where considerable recontamination was observed 7 to 8 years after soil was removed to a 6-inch depth (Stokes, 1987). However, the reason for the recontamination was thought to be due to contamination of the replacement soil by adjacent polluted soil that had not been removed (Jones, 1987), not by contaminated soil from deeper levels.

For practical purposes, properly conducted soil removal to a depth of 6 inches should suffice in urban residential areas that are restricted to grass, shrubs, or shallow gardens. However, the

depth of soil contamination should be assessed at each site, and the decision regarding depth should be made based on the results of the soil sampling and anticipated use of the land. For most residential areas, the depth of removal will not exceed 6 inches. Records of the soil sampling and abatement that occurs should be maintained with the permanent records of the property. These records will alert property owners who are planning excavations to depths below the abatement depth, such as for water or sewer line work, to use caution to avoid contaminating the surface soil with excavated soil. The owners should be advised to sample the soil below the abatement depth to determine the lead concentrations so that procedures can be implemented to segregate this deeper soil, if contaminated, and to use it as fill for the deeper areas of the excavation when the work is completed. The maximum allowable lead concentration in replacement soil shall not exceed 200 µg/g.

### *Types of Equipment*

Removal and replacement of soil in residential abatement situations may take place in both large and small sites. Some urban yards are very small, consisting of only a few square feet; others are larger, but are sometimes surrounded by buildings. Therefore, residential soil abatement will often require the use of extensive manual labor in addition to mechanical soil removal. When soil is removed by hand, it generally can be loaded into wheelbarrows and then offloaded to other vehicles to be transported to the disposal site. Rather than offload the wheelbarrows to dump trucks, it is usually more efficient to dump the soil directly into rolloff containers, which are then loaded onto trucks for transport to the disposal site.

### *Sod and Seeded Grass Maintenance*

All grass sod planted as part of the abatement operation should be maintained until the end of the growing season. This maintenance should include initial frequent watering to establish the rooting of the sod and germination of the grass seed, followed by watering on a regular basis to keep the grass in a healthy state. Under some



conditions, seeding the soil may be practical, but often it is not realistic to restrict use of the soil area for the length of time needed to establish newly seeded grass.

### *Utilities*

The owner or contractor should contact the local United Utilities Protection Service (UUPS), “Miss Dig,” or “Miss Utility” (coordinated information sources for all utilities) before beginning work to obtain exact locations of all underground utility lines. If a utilities information service does not exist in the community, the individual utilities should be contacted directly. The American Public Works Association (APWA)—(816) 472-6100, ext. 584—can also provide local phone numbers for utility line identification services (APWA, 1993).

Care should be taken to protect existing utilities during abatement to prevent any damage to existing underground and overhead utilities and to prevent any harm to human life and property. If a contractor is used, the owner should require the contractor to protect the existing utilities and to make good any damage to these utilities as quickly as possible.

### *Existing Fences*

Care should be taken while removing existing fencing for worksite access. Such fencing should be salvaged and reinstalled (if it does not contain lead-based paint) to the satisfaction of the owner. In some cases, fencing may have to be replaced.

### *Protection of Adjacent Areas*

When working adjacent to excluded areas, including sidewalks, fences, trees, and patios, the soil should be excavated at a 45° (1:1) slope away from the excluded areas so that contamination does not wash or roll into the excluded area.

### *Inclement Weather*

Removal and/or replacement operations should be suspended at any time when satisfactory control of the overall operation cannot be

maintained on account of rain, wind, or other unsatisfactory weather or ground conditions. Determination of such conditions should be made by the owner or project consultant. When such conditions exist, the work area should be cleaned up immediately and work suspended. High winds can disperse contaminated soil and dust to offsite areas and runoff from rain can carry contamination outside the abatement area.

### *Vehicle Operation*

Prior to hauling contaminated soil, a vehicle operation plan should be prepared for the equipment and hauling vehicle operators, which includes but is not limited to information on the cleaning of vehicles, securing of tarps and tailgates, ticketing of trucks, unloading of material, and handling of spilled soil.

All trucks, hauling vehicles, and containers loaded with contaminated soil should be inspected for loose material adhering to the outside of the body, chassis, or tires before departure from the worksite. Such material should be cleaned up before the vehicle leaves for the disposal site. If the truck tires made contact with the contaminated soil, they should be cleaned before the trucks leave the work area. The tires should be brushed off on a plastic sheet and the contaminated soil loaded onto the truck or returned to the lot being excavated.

Soil should be loaded directly into dump trucks or disposal containers from the worksite. If possible, there should be no “double handling” of contaminated material, such as shoveling the soil into a wheelbarrow, moving it to another location, dumping it, and shoveling it again into another container. This double handling not only wastes time but also increases the likelihood of spreading the contamination and tends to make site cleanup more difficult.

All soil removed from the worksite should be placed in dump trucks for transport to the disposal site. The trucks should have secure fitting tarps and sealed tailgates to reduce leakage as much as possible.

Loaded trucks or containers may be left onsite overnight provided they are secured to prevent access or leakage. It is not advisable to leave loaded trucks or containers onsite over the weekend. Any piece of equipment, whether a dump truck or excavation equipment, should be cleaned before it is removed from the site. Before decontamination, the equipment should be placed on 6-mil polyethylene plastic. Decontamination of equipment can be achieved by first scraping soil from all surfaces and then brushing to remove all visible soil, using water spray to prevent dispersion. The soil removed must be contained for appropriate disposal.

### *Final Grade*

The final grades of replaced soil should be 2 inches above existing grades to allow for settling and to ensure that all drainage is away from existing structures.

### *Existing Vegetation*

A number of precautions are needed to protect existing vegetation, such as bushes and trees. It is advisable to tie trees and shrubs to ensure stability.

Hand tools are needed to scrape soil from around roots without undermining or damaging them. Any large roots should be left undisturbed.

### *Tool Contamination*

To minimize the cross-contamination between excavation and replacement worksites, separate tools should be provided for the excavation and replacement operations. A less expensive alternative is to employ an acceptable method for decontamination of tools, workers' clothing, and footwear. The decontamination should include physically removing as much soil as possible and then washing and rinsing the contaminated items with water.

All workers should clean their boots thoroughly before leaving the work area. The soil removed from boots should be disposed of either in a truck used for hauling contaminated soil or left in the worksite.

### *Soil Replacement and Cleanup*

Prior to soil replacement, all walks, driveways, lanes, and streets adjacent to the excavation area should be cleaned of all contaminated soil. All loose soil should be scraped, washed, and swept from the above-mentioned surfaces. No clean soil should be placed down until all contamination has been removed from these areas.

At the completion of the workday, all loose contaminated soil within the limits of the work area should be collected. The collected soil should be transferred to a dump truck or other container for subsequent disposal.

All hard surfaces, such as sidewalks, paved driveways, and patios, should be cleaned at the completion of each workday. This daily cleanup should consist of scraping, washing, vacuuming, and wet sweeping all soil from the above-mentioned surfaces.

Cleanup procedures should begin early enough so that they can be completed before the end of the workday.

### *Prevention of Contamination From Underlying Soil*

Regardless of the depth of removal, the possibility of contamination of the replacement soil from the underlying unexcavated soil exists, particularly from future activities. One way to minimize this occurrence is by laying a water-permeable fabric (geotextile) or similar lining at the bottom of the excavated areas to provide a visual demarcation between replaced soil and original soil (Weitzman, 1993). This liner can serve as a warning for persons digging in the future to exercise caution so that contaminated soil beneath the liner does not become mixed with the replacement soil.

### *Contaminated Soil Load Manifest System*

In order to keep track of the contaminated soil being hauled away from the site, a load manifest system should be used to keep an exact record of the time and location of disposal. The manifest should consist of a two-part ticket, with one ticket given to the owner at the time of truck



departure and the other held by the hauler. The disposal site ticket should be presented to the site owner or inspector technician before the end of the workday on which the material was deposited in the dump site. The purpose of the manifest system is to ensure that the contaminated soil is not used as fill in other residential areas.

If the soil is considered to be hazardous waste, the EPA manifest system must be used before any transportation or disposal offsite occurs (see Chapter 10). Even if the soil is not hazardous waste, it should be manifested using an alternative system such as the one described above.

### *Prevention of Offsite Movement of Contaminated Soil*

Contaminated soil should be removed from the site as soon as possible to prevent wind and water erosion. To prevent offsite migration and to avoid the possibility of tampering by children, piles of contaminated soil should not be left onsite overnight. Wind erosion can occur on any site. Water erosion is more likely on hilly sites or during heavy precipitation. Exposed sites can be covered with plastic and secured in place to prevent offsite migration of contaminated soil. An alternative method is to wet down the site at the end of the workday to prevent wind erosion. Similar problems will be encountered when contaminated soil is stockpiled during the day prior to disposal at the end of the day. In this case, wind and water erosion should be controlled by using a combination of plastic sheeting and silt fencing.

### *Site Control*

The following precautions should be taken:

- ◆ To prevent the spread of contaminated soil, secure working limits should be defined for each area of excavation. Access to this area should be restricted to authorized personnel with entrances and exits controlled.
- ◆ The abatement work area should be enclosed with temporary fencing or adequate barricades to prevent unauthorized personnel or animals from entering the work area.
- ◆ Yellow caution tape should be installed across doors leading to abatement areas.
- ◆ Access routes to homes should be maintained at all times. Such routes should not require passing through the area of excavation.
- ◆ The removal of a partial grass cover in preparation for the laying of sod or grass seeding may *temporarily* increase the amount of bare contaminated soil. Onsite exposure could result from children playing on the exposed soil. Abatement workers can control this during the day by means of adequate site control. However, control is difficult, if not impossible, after the end of the workday. Lead hazard warning signs should be posted to warn residents.
- ◆ In order to minimize inconvenience to residents and neighbors and to minimize exposure, abatement of a particular site should be completed within 1 workday.

## 2. Soil Cultivation

Since soil lead concentration often decreases with increasing depth, soil mixing can be considered to be an abatement strategy. If the average lead concentration of the soil to be abated is below 1,500  $\mu\text{g/g}$ , thorough mixing is an adequate abatement method. Pilot testing may be necessary to determine the type of mixing process needed. Rototilling may not be effective.

## 3. Soil Cleaning

The following soil treatment methods are being investigated for possible use on residential sites:

- ◆ Magnetic separation.
- ◆ Froth flotation.
- ◆ Washing.

Magnetic separation and froth flotation are currently under development and are not addressed in these *Guidelines*. The method that has received the most attention thus far is soil washing. Soil washing is a waterborne process for mechanically scrubbing soils to remove lead

and other contaminants (EPA, 1990b). The soil is removed from the yard but usually washed onsite. The process removes contaminants in one of two ways: by dissolving or suspending them in the wash solution (which is later treated by conventional wastewater treatment) or by concentrating them into a smaller volume of soil through simple particle size separation techniques. Soils containing coarse sand and gravel are more responsive to cleaning techniques than soils containing a large amount of clay and silt. If the washing process involves the addition of surfactants or other chemicals to separate the lead-containing particles, care must be taken to ensure that amounts remaining in the remediated soil do not interfere with reuse of the soil at the site. Most soil washing in the United States has been done at Superfund sites. Soil washing has not yet been attempted at residential sites. EPA is currently investigating the applicability of soil washing to residential soil abatement.

#### 4. Paving

If contaminated soil is present in high-traffic areas, the soil can be covered by a high-quality concrete or asphalt. In this case, contaminated soil need not be removed before paving. Normal precautions associated with thermal expansion or contraction and traffic load should be considered. Hard surfaces are not appropriate in play areas where falls are possible from slides, jungle gyms, etc. The Consumer Product Safety Commission has developed recommendations for fall surfaces in public play areas (CPSC, 1991).

#### C. Exterior Dust Control

Lead in exterior dust can be a source of exposure to children because it can be tracked inside and carried on the skin, especially the hands (Bornschein, 1986). For example, in older urban areas in Cincinnati, exterior leaded dust concentrations are on average about four times higher than interior leaded dust concentrations, and exterior lead surface loadings are much higher than for interior dust (Clark, 1993).

Just as children can be directly exposed to leaded soil, they can also be exposed to exterior leaded dust. Exterior dust can also migrate by various means (children, adults, pets, or wind) to the interior of homes where there are many opportunities for exposure to children. Exterior leaded dust concentrations up to 50,000  $\mu\text{g/g}$  (equivalent to 5 percent lead in dust) have been measured in urban areas in the EPA Soil Lead Abatement Demonstration Project (EPA, 1993c).

If only an individual property is involved in the exterior dust control activity, the type of equipment that can be used will be limited by the size of the area involved and the person responsible for the area. Owners are not required to clean streets, for example. Because of the mobility of exterior dust, the length of time that the dust cleanup remains effective will be limited by the size of the abatement area and therefore may need to be repeated periodically.

Exterior dust control consists of two components:

- ◆ Controlling sources of lead-contaminated dust.
- ◆ Removing lead-contaminated dust from paved areas.

Without adequate control of the sources of lead in exterior dust, recontamination of the exterior areas will occur. Studies of a schoolyard area indicated that leaded dust concentrations equalled preabatement levels within 1 year in Winnipeg, Ontario (Stokes, 1988). Recontamination of some paved areas in Cincinnati occurred within a few days (Clark, 1991) indicating that repeated cleaning and control of the *sources* of the lead are necessary.

#### 1. Types of Equipment

Exterior dust cleanup consists of removing as much dust and dirt as possible from all paved surfaces on the property or properties involved. Lead-contaminated dust can be found on paved surfaces such as sidewalks, patios, driveways,

parking areas, etc. For multiple adjacent properties that are being abated, cleanup of streets, alleys, or other common areas should be considered, although this is normally a municipal responsibility. Brick-paved areas present the biggest challenge in removing exterior dust because they contain numerous cracks. For individual properties, hosing off walkways and play areas periodically may reduce exterior lead dust levels.

In order to meet this cleaning challenge, it is necessary to have available the most efficient hard-surface vacuum cleaning equipment. Many commercial contract cleaning firms located in urban areas have such equipment.

There are at least three different types of suitable paved-surface cleaning machines:

- ◆ Hand-pushed HEPA vacuum cleaners.
- ◆ Vacuum-assisted sweepers, which are similar to the traditional broom sweeper, with the added feature of a slight vacuum that assists in controlling dust and transporting material from the broom bristles to the hopper.
- ◆ Vacuum sweepers, which lift material from paved surfaces—some are equipped with curb brushes to assist in transporting the material from the edge of the cleaning area to the vacuum head and into the hopper.

EPA research has found that regenerative air machines, which depend on rapidly moving air to capture particles from the source of the pavement, frequently remove only a small fraction of the dust and thus may not be suitable for lead abatement work (Pitt, 1985).

## 2. Evaluation of Equipment

A number of pavement cleaning machines were tested as part of the Cincinnati Soil Lead Abatement Demonstration Project (Clark, 1993). The machines tested were the vacuum-assisted sweeper, the vacuum sweeper, and the regenerative air machine. Initial tests demonstrated that several machines operated



Figure 12.25 Paving Bare Soil May Be the Best Option for High-Traffic Areas.

above the 90-percent efficiency level. A machine performing at the 90-percent efficiency level will pick up 90-percent of the available dirt after two passes. Equipment tested involved both large machines suitable for streets and parking lots and some walk-behind, vacuum-assisted broom sweepers suitable for sidewalks and other smaller areas. Several larger machines performed at or above the 90-percent efficiency rate. Some of the smaller walk-behind sweepers did not perform at an acceptable level of efficiency.

Care must be taken when emptying the collected dust from the machines. The most appropriate method to minimize dust release is to dampen the contents of the hopper using an accessible hose. If water is to be used for dust control, it will be necessary to devise a means of containing excess water. This can be achieved by placing 6-mil polyethylene plastic on the ground where the equipment is being emptied and carefully collecting the water after the hopper has been emptied. It is also necessary to perform this operation in a secure area so that children are not exposed.



### 3. Removal of Heavy Accumulation

The first step in cleaning an area should be the removal of heavy accumulations of dust and debris. The heavily accumulated areas can be cleaned either by manually removing the material with scrapers, shovels, or brooms or by vacuuming the heavily accumulated areas if vacuuming proves to be adequate in removing the contamination. Just as in handling lead-contaminated soil, the heavy accumulations of exterior dust should be dampened.

### 4. Vacuum Cleaning

Small areas, such as sidewalks and patios that are inaccessible to larger cleaning machines, may be cleaned with an acceptable HEPA filter-equipped vacuum cleaner. Surfaces should be vacuumed continuously until no additional visible dust is being removed by further vacuuming.

# Chapter 14: Cleaning

HOW TO DO IT .....	14-3
I. Introduction.....	14-5
A. Performance Standard .....	14-5
B. Small Dust Particles .....	14-6
C. Difficulties in Cleaning.....	14-6
1. Worker Inexperience.....	14-6
2. High Dust-Producing Methods and/or Inadequate Containment.....	14-7
3. Rough Surfaces .....	14-7
4. Rushing to Meet Tight Deadlines.....	14-7
II. Coordination of Cleaning Activities.....	14-7
A. Checklist .....	14-7
B. Equipment Needed for Cleaning .....	14-8
C. Waste Handling and Disposal .....	14-8
III. Cleaning Methods.....	14-9
A. Vacuums: HEPA vs. non-HEPA .....	14-9
B. HEPA Vacuums .....	14-10
C. Emptying the Vacuum .....	14-11
D. Wet Cleaning .....	14-12
IV. Cleaning Procedures Before and During the Work.....	14-13
A. Cleaning Before Work Begins.....	14-14
B. Ongoing Cleaning During the Job .....	14-14
C. Daily Cleaning .....	14-14
1. Large Debris .....	14-15
2. Dust and Small Debris .....	14-15
3. Exterior Cleaning .....	14-15
4. Worker Protection Measures .....	14-16
5. Maintaining Containment.....	14-16
V. Final Cleaning Procedures.....	14-16
A. Decontamination of Workers, Supplies and Equipment.....	14-16
B. Cleaning and Removal of Protective Sheeting .....	14-17
C. Vacuuming and Wet Cleaning.....	14-17
D. Supervisor's Preliminary Visual Inspection.....	14-19
E. Surface Painting or Sealing of Non-Floor Surfaces.....	14-19
F. Sealing Floors .....	14-19
G. Final Wet Cleaning, EPA Cleaning Verification, and Possible Pre-Clearance Dust Testing.....	14-19
H. Clearance.....	14-21

I. Recleaning After Clearance Failure ..... 14-21

REFERENCES ..... 14-22

**FIGURES**

**Figure 14.1** There are many brands of HEPA vacuums on the market..... 14-8

**Figure 14.2** Vacuum with a HEPA filter and special attachments..... 14-10

**Figure 14.3** Sizes of HEPA vacuums and attachments. .... 14-11

**Figure 14.4** Three-bucket cleaning system..... 14-13

**Figure 14.5** HEPA vacuum and wet wash technology. .... 14-13

**Figure 14.6** Removing large debris. .... 14-15

**Figure 14.7** Exterior clean up. .... 14-16

**Figure 14.8** Vacuuming the floor containment. .... 14-17

**Figure 14.9** Inspecting for completeness of the work performed. .... 14-19

**Figure 14.10** The HEPA Vacuum-Wet Wash-HEPA Vacuum Cycle Helps,  
Meet Clearance Standards..... 14-20

**Figure 14.11** Wet Cycle Requires Washing All Surfaces with Suitable Detergents..... 14-20

**Figure 14.12** Use a Three-Bucket System and Then HEPA Vacuum,  
Again to Minimize Recontamination ..... 14-20

**Figure 14.13** HEPA vacuum all surfaces a final time..... 14-20

**TABLE**

**Table 14.1** Summary Guidance on Cleaning Methods by Dustiness of Work  
and Condition of the Surface. .... 14-18

# Chapter 14: Cleaning

## How to Do It

1. **Include cleaning in plans for the work.** Include written step-by-step procedures for precleaning, cleaning during the job, and daily and final cleanings in the project design or specifications, using information contained in this chapter. Assign responsibilities to specific workers for cleaning and for maintaining cleaning equipment. Have sufficient cleaning equipment and supplies *before* beginning work, including:
  - ◆ Detergent
  - ◆ Waterproof gloves
  - ◆ Disposable rags
  - ◆ Mops
  - ◆ Buckets
  - ◆ Vacuum (preferably HEPA-equipped) with attachments (crevice tools, beater bar for cleaning rugs, etc.)
  - ◆ Plastic bags for disposal of debris and heavy duty protective sheeting (of sufficient thickness to prevent puncture)
  - ◆ Debris containers (heavy duty plastic bags are adequate for most jobs)
  - ◆ Containers for dirty wash water
  - ◆ Shovels
  - ◆ Rakes
  - ◆ Water-misting sprayers
  - ◆ Heavy duty polyethylene sheeting (or equivalent) of sufficient thickness to prevent puncture (e.g., 6 mil).
2. **Restrict access to work area.** Do not allow residents to enter the work area until cleaning is completed and clearance is established.
3. **Clean before starting work.** If contamination is extensive, conduct precleaning of the dwelling unit and furnishings, if needed, before beginning paint-disturbing work. Move and/or cover all furniture and other objects.
4. **Conduct ongoing cleaning during the work.** Conduct ongoing, continual cleaning during high-dust jobs, including regular removal of large and small debris and dust. Decontamination of all tools, equipment, and worker protection gear is required before such items are removed from containment areas. Electrical equipment should be wiped and vacuumed, not wetted down, to minimize electrocution hazards.

5. **Clean at the end of each work day.** For high-dust jobs, schedule sufficient time (usually 30 minutes to one hour) for a complete daily cleaning, starting at the same time near the end of each work day after paint-disturbing activity has ceased.
6. **Wait one hour before final cleaning.** For final cleaning, wait at least 1 hour after active paint-disturbing activity and other dust-generating work has ceased to let dust particles settle.
7. **Clean and remove protective sheeting used for dust containment.**
8. **Use both vacuuming and wet cleaning.** Clean all surfaces, using the two basic cleaning methods, vacuuming and/or wet cleaning. Cleaning procedures may vary, depending on the amount of dust generated by the job and the smoothness of the surfaces to be cleaned. A three-phase, vacuum-wet cleaning-vacuum cycle is recommended for high-dust jobs with some rough or porous surfaces. For low-dust jobs with all smooth surfaces, wet cleaning may be adequate to pass clearance. Surfaces that are badly soiled often require extra manual effort, involving hand wiping until no more visible dirt comes up. Other cleaning methods are acceptable, as long as clearance criteria are met and workers are not overexposed.
9. **A HEPA vacuum is required if a vacuum is used.**
10. **Follow the cleaning sequence, "ceiling to floor and out the door."** For high-dust jobs, vacuum all surfaces in the room (ceilings, walls, trim, interior window sills, window troughs, hard surface floors, and other horizontal surfaces). Start with the ceiling and work down, moving toward the entry door ("ceiling to floor and out the door"). Completely clean each room before moving on. For low-dust jobs, it is not necessary to clean ceilings and walls, except that they should be cleaned if they were the surfaces on which the work was done. See Chapter 8 for a description of low-dust and high-dust jobs.
11. **Use a common detergent, not TSP (Trisodium Phosphate).** Use a standard household detergent, not a high-phosphate detergent, to dislodge any ground-in contamination. Use either the three-bucket system described in this chapter, or a use-once-and-toss system, as also described below. If buckets are used.
12. **Inspect visually.** After final cleaning, the supervisor should perform a visual inspection to ensure that all visible dust and debris has been removed. Reclean if necessary.
13. **Paint and/or seal, if necessary.** Paint or otherwise seal treated surfaces and interior floors, if necessary.
14. **Final wet cleaning.** After painting that has followed high-dust jobs, conduct a final wet cleaning of horizontal surfaces.
15. **Clearance.** Workers should stay out of cleaned rooms until after the clearance examination. Conduct a clearance examination (see Chapter 15). (Clearance, while recommended by HUD, is not required by regulations in certain circumstances, such as for *de minimis* projects under HUD's Lead Safe Housing Rule or under the EPA's Renovation, Repair, and Painting Rule., which requires cleaning verification for most projects; see Chapter 11.)
16. **Repeat cleaning and clearance (or cleaning verification), if necessary. Continue clearance testing (or cleaning verification) until the dwelling unit or work area passes.** If the unit fails, repeat cleaning of all of the surfaces that failed and all other surfaces represented by the surfaces that failed.
  - ◆ As an incentive to conduct ongoing cleaning and a thorough final cleaning, the cost of repeated cleaning after failing to pass clearance or cleaning verification should be borne by the contractor, not the owner, as a matter of the job specification.

## I. Introduction

This chapter describes cleaning procedures to be employed before, during and following lead-based paint abatement, interim controls and other renovation or maintenance work that may create lead-contaminated dust. Dust removal as an interim control measure is covered in Chapter 11.

All lead hazard control activities and many other paint-disturbing jobs can produce dangerous quantities of lead-contaminated dust. Unless this dust is properly removed, a dwelling unit may be more hazardous after the work is completed than it was originally. Whenever possible, ongoing and daily cleaning of settled dust during lead hazard control and renovation projects is recommended. Ongoing and daily cleaning are also necessary to minimize worker exposures by removing excess dust from the work area.

Cleaning is the process of removing visible dust and debris *and* dust particles too small to be seen by the naked eye. Removal of lead-based paint hazards in a dwelling unit will not make the unit safe unless excessive levels of leaded-dust are also removed. This is true regardless of whether the dust was present before the work or generated by the work itself. Improper cleaning can increase the cost of a project considerably because additional cleaning and clearance sampling will be necessary. However, cleaning and clearance can be achieved routinely if care and diligence are exercised.

The cleaning methods and procedures described in this chapter are for hard surfaces. Workers should not attempt to clean carpets or rugs following lead hazard control or other paint disturbing work unless they know that the carpets are new and therefore are not likely to contain lead-contaminated dust embedded in the fibers and backing, or unless the workers are prepared to spend hours vacuuming the carpeting over and over again until the deeply embedded dust is removed. Vacuuming an old carpet may bring some of the embedded dust to the surface of the carpet, increasing the dust-lead loading levels on the surface and thus increasing the likelihood that children will be exposed to lead in the dust and that the carpet will *not* pass clearance (Ewers, 1994). Therefore it is better to clean and carefully remove the protective sheeting that is over the carpet (as described later in this chapter), and then have clearance dust-wipe sampling performed on the carpet. If lead levels on the surface of the carpet are found to exceed the clearance standard (which is the same as the hazard standard in EPA regulations), it will be necessary to either thoroughly clean the carpet or dispose of it. See Section V.B.2 of Chapter 11 for guidance on dust removal from carpets.

### A. Performance Standard

The cleaning methods described in this chapter are designed to achieve clearance. (The clearance examination, which includes a visual assessment and dust sampling, is described in Chapter 15.) Although these cleaning methods are feasible and have been shown to be effective in meeting clearance standards, other methods may also be used if they are safe and effective. This performance-oriented approach should stimulate innovation, reduce cost, and ensure safe conditions for both residents and workers.

According to EPA (40 CFR 745.227(d)(8)(viii)) and the HUD regulations (24 CFR 35.1320(b)(2)(i)) that follow the EPA regulations, the permissible amount of lead in dust remaining on each of the following surfaces following lead hazard control work – the clearance standards – must be less than the following levels:

- ◆ 40  $\mu\text{g}/\text{ft}^2$  on floors (both hard-surfaced and carpeted),
- ◆ 250  $\mu\text{g}/\text{ft}^2$  on interior window sills (stools), and

- ◆ 400 µg/ft<sup>2</sup> on window troughs (the area where the sash sits when closed, plus the area of the exterior sill between the sash and the frame for the screen and/or storm window, if present).

These levels are based on wipe sampling. They apply to single-surface wipe samples and to composite wipe samples with only two subsamples. To evaluate the results of a composite sample with more than two subsamples, the standards listed above must be divided by one-half the number of subsamples. (Note that these *Guidelines* do not recommend the use of composite wipe sampling; see Chapter 15.)

If state, local or tribal standards are more stringent, they apply. Note that EPA and HUD require clearance of window troughs for abatement and for other lead hazard control work covered by HUD's Lead Safe Housing Rule above *de minimis* amounts. A clearance examination includes wipe sampling of window troughs as well as interior window sills and floors.

Clearance is not easily attained. Over 20 percent of the dwellings enrolled in the evaluation of the HUD Lead Hazard Control Grant Program failed to pass clearance on the first try, and the clearance levels applicable at the time of the study were at least twice as high as those listed above and thus less difficult to achieve (NCHH, 2004).

## **B. Small Dust Particles**

Dust particles that are invisible to the naked eye remain on surfaces after ordinary cleaning procedures. A visibly clean surface may contain unacceptably high levels of lead in dust particles and require special cleaning procedures.

## **C. Difficulties in Cleaning**

Although cleaning is an integral and essential component of any lead hazard control activity, it is also the part of the activity that when conducted improperly is most likely to cause clearance failure. Common causes for this failure include worker inexperience, high dust-producing methods, rough surfaces, and tight deadlines.

### **1. Worker Inexperience**

To understand the level of cleanliness required to meet the established clearance standards, workers often require a significant reorientation to cleaning. Many construction and maintenance workers are used to cleaning only dust that they can see, not the invisible dust particles that are also important to remove.

Any worker performing cleaning for either clearance or cleaning verification needs training and hands-on practice in the stringent levels of cleaning required to pass clearance or cleaning verification.

Many of the cleaning methods described in this chapter are not standard, traditional procedures for general home improvement contractors and maintenance crews. Therefore, owners and managers must ensure that contractors and crews follow the specialized cleaning procedures recommended herein or specially designed alternative procedures, even though some steps may appear to be redundant or unnecessary. These methods have been shown to be feasible and effective in many situations, and skipping steps in the cleaning procedures may increase the possibility of failing clearance and harming children.

## 2. High Dust-Producing Methods and/or Inadequate Containment

High dust-generating methods during the hazard control or renovation work, inadequate dust containment, and poor work practices can all make achievement of clearance particularly difficult. Dust generated by the work should be contained, to the extent possible, to the inside of work areas. Floors and any furnishings left in the work area should be carefully covered with impermeable protective sheeting. Inadequately constructed or maintained containment or poor work practices will result in additional cleaning efforts, due to dust that has blown out or been tracked out of the work area. Work practices necessary to prevent spreading of dust throughout a dwelling (e.g., by tracking dust out of work areas) are essential. See Chapter 8 for guidance on worksite preparation and other work practices.

## 3. Rough Surfaces

It is often difficult to dislodge dust in the crevices of rough, pitted or cracked surfaces, yet small amounts of dust in such locations can be picked up in clearance wipe samples and cause clearance failure. Making surfaces smooth and cleanable increases the likelihood of achieving clearance.

## 4. Rushing to Meet Tight Deadlines

Daily and final cleanings have sometimes been compromised due to project deadlines, since cleaning comes at the end of the job. Hurried efforts often result in clearance failure. Delayed and over-budget projects are often the result of repeated, unplanned recleanings that are necessitated by inadequate containment and careless work practices, including rushed clean-ups.

# II. Coordination of Cleaning Activities

## A. Checklist

The owner or contractor may use the following cleaning checklist before any lead hazard control or renovation activity.

- ◆ Is the critical importance of cleaning understood by the project supervisor / certified renovator / abatement supervisor, and all workers on the job?
- ◆ Have all workers been trained for hazard control work or lead-safe work practices?
- ◆ Have all workers carefully studied the step-by-step procedures for precleaning before the work begins (if needed), in-progress cleaning, and daily and final cleanings?
- ◆ Have the before-work, daily, and final cleanings been scheduled properly and coordinated with the other participants in the project?
- ◆ Have cleaning equipment, materials and supplies been obtained?
- ◆ Do the workers know how to operate and maintain special cleaning equipment, do they have directions for the proper use of all cleaning materials, and are they receiving adequate supervision of their cleaning activities?

- ◆ Are all workers properly protected during the cleaning processes (see Chapter 9)?
- ◆ Have provisions been made to properly handle and dispose of waste (see Chapter 10)?
- ◆ Have visual inspections and clearance testing (or cleaning verification) been arranged (see Chapter 15)?
- ◆ Are the clearance (or cleaning verification) criteria to be met fully understood?
- ◆ Have all appropriate surfaces been properly painted or otherwise sealed?

### B. Equipment Needed for Cleaning

The following equipment is needed to conduct cleaning: a high-efficiency particulate air (HEPA) filter vacuum cleaner, and attachments (crevice tools, beater bar or agitator head for cleaning carpets and rugs, etc.) (see Figure 14.1); detergent; water-proof gloves; rags, mops, and buckets; heavy-duty plastic bags (preferably 6-mil) for debris; waste water containers; shovels (and rakes, if needed) for debris removal; water-misting sprayers; and disposable, impermeable protective sheeting, such as polyethylene plastic sheeting of a thickness to prevent puncture (e.g., 6-mil).



**FIGURE 14.1** There are many brands of HEPA vacuums on the market.

### C. Waste Handling and Disposal

Generally, dirty water used in cleaning should be disposed of down a toilet. Do not pour dirty water onto the ground or down a storm sewer. Vacuum and/or wet clean protective sheeting. Vacuum contaminated disposable clothing. Wrap or bag (with heavy-duty plastic) disposable clothing and protective sheeting, architectural debris, paint strippings, paint chips and dust, vacuumed debris and vacuum filters, rags, and other material. Seal the packages with tape and store them temporarily in a secure location (such as a locked large metal bin for refuse, e.g., a Dumpster®). Dispose of the waste in an appropriate State-permitted solid waste facility, unless the waste is exempt from that requirement. See the next paragraph and Chapter 10 for further information on waste disposal.

EPA has stated that waste generated by lead-based paint activities in housing falls under the household waste exemption in the Resource Conservation and Recovery Act (RCRA) (EPA, 2000b). The household waste exemption applies to waste generated by contractors as well as to waste generated by residents, and it applies to all lead-based paint activities, including abatement, interim control, and renovation and remodeling of housing. Types of housing included in the household waste exemption are single-family homes, apartment buildings, public housing, and military barracks. HUD and EPA both recommend that the lead-safe practices described above and in Chapter 10 be followed to reduce the likelihood that household waste will contaminate the environment.

States and local governments may institute hazardous waste requirements applicable to lead activities in housing. Owners and contractors should determine what, if any, state or local regulations apply, and should comply with them.

### III. Cleaning Methods

Two basic cleaning methods have proven effective, especially when used concurrently: (1) vacuuming, using a high-quality vacuum cleaner equipped with a HEPA exhaust filter, and (2) wet cleaning with a household detergent and rinsing. Trisodium phosphate (TSP) is not recommended, as explained below in Section III.D. A proven cleaning procedure is a three-pass system, in which the surface is first vacuumed to remove as much dust and small debris as possible, then wet-cleaned to dislodge fine dust, and finally vacuumed again to remove any remaining particles. However, it may not be necessary to use all three steps on all surfaces. As explained in Section V below, research indicates that the way these methods should be used depends on whether the work was a high-dust or low-dust job and whether the surfaces being cleaned are smooth or rough (Dixon, 2004; California Dept. of Health Services, 2004).

#### A. Vacuums: HEPA vs. non-HEPA

If a vacuum cleaner is used during lead hazard control projects, renovation projects, or other work covered by OSHA regulations, the vacuums must be a HEPA vacuum. This section provides technical information on the various types of vacuum cleaners.

HEPA vacuums differ from conventional vacuums in that they contain high-efficiency filters that are capable of trapping extremely small, micron-sized particles. These filters can remove particles of 0.3 microns or greater from air at 99.97 percent efficiency or greater. (A micron is 1 millionth of a meter, or about 0.00004 inches.) Some vacuums are equipped with an ultra-low penetration air (ULPA) filter that is capable of filtering out particles of 0.13 microns or greater at 99.9995 percent efficiency. However, these ULPA filters are slightly more expensive, and may be less available than HEPA filters. (Note that, when HEPA vacuums are specified by regulations or specifications, ULPA filter vacuums may be used because of their greater dust collection efficiency.)

Experts have recommended using HEPA vacuums to cleanup leaded-dust because conventional vacuums, without the high efficiency filter, may send very fine lead-dust particles out the exhaust and back into the indoor environment. One study in 1992 supported this view (CMHC, 1992). More recent studies, however, have found that the difference in collection efficiency between HEPA and non-HEPA vacuums is not significant (California Department of Health Services, 2004; Rich, 2002; and Yiin, 2002).

There is more to a vacuum than the filter. Other important factors that determine the effectiveness of a vacuum are particle lifting velocity (which is a function of the motor, the design of the suction tool, and the extent to which the rest of the system does not release air before it is supposed to), quality of construction (which may determine the durability of the machine and whether there are air pressure leaks before the filtration), and whether the vacuum has special tools, such as a crevice tool (see Figure 14.1). These *Guidelines* recommend that a high-quality HEPA vacuum be used if possible; however, a high-quality household or commercial vacuum should be used if a HEPA vacuum is not available. The California study cited in the previous paragraph found that a HEPA vacuum was actually less effective in removing dust-lead from vinyl floors than non-HEPA vacuums, probably because the suction tool was not well designed for the job. Also, filters are available that, while not HEPA, are better than those that formerly were standard on household and commercial vacuums. One additional benefit of a HEPA filter is that it may catch other contaminants in the residential environment, such as allergens, in addition to very fine lead particles.

**B. HEPA Vacuums**

This section provides background information on HEPA vacuums.

**Operating Instructions**

There are numerous manufacturers of HEPA vacuums. Although all HEPA vacuums operate on the same general principle, they may vary considerably with respect to specific procedures, such as how to change the filters. To ensure the proper use of equipment, the manufacturer’s operating instructions should be carefully followed and if possible, training sessions arranged with the manufacturer’s representative.

Although HEPA vacuums have the same “suction” capacity as ordinary vacuums that are comparably sized, their filters are more efficient. Improper cleaning or changing of HEPA filters may reduce the vacuum’s suction capability.

**Special Attachments**

Because the HEPA vacuum will be used to vacuum surfaces other than floors, operators should buy attachments and appropriate tool kits for use on different surfaces (such as brushes of various sizes, crevice tools, angular tools, etc.), as is true with conventional vacuums (see Figure 14.2).

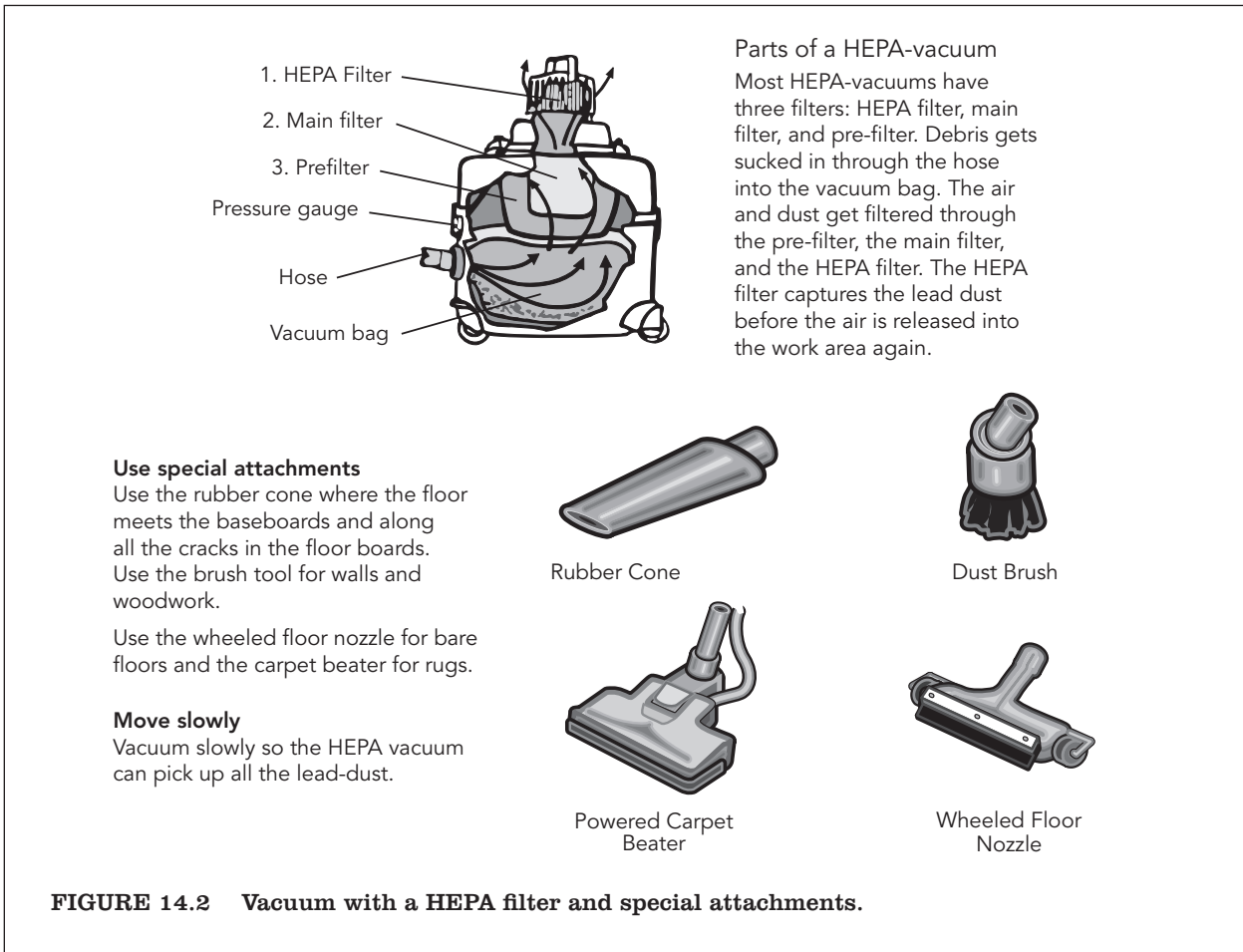

### Selecting Appropriate Size(s)

HEPA vacuums are available in numerous sizes, ranging from a small lunch bucket-sized unit, which may be carried like a backpack, up to truck-mounted systems. Two criteria for size selection are the size of the job and the type of electrical power available. Manufacturer recommendations should be followed (see Figure 14.3).

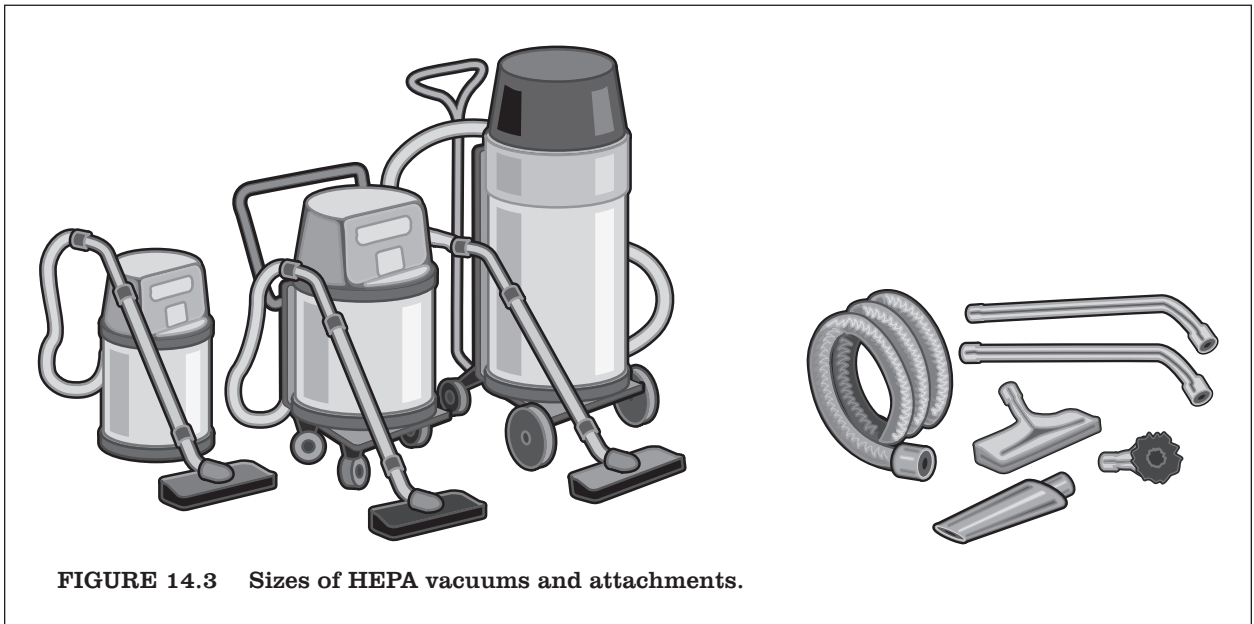

**FIGURE 14.3** Sizes of HEPA vacuums and attachments.

### Prefilters

HEPA filters are usually used in conjunction with a prefilter or series of prefilters that trap the bulk of the dust in the exhaust air stream, particularly the larger particles. The HEPA filter traps most of the remaining small particles that have passed through the prefilter(s). All filters must be maintained and replaced or cleaned as specified in the manufacturer's instructions. Failure to do so may cause a reduction in suction power (thus reducing the vacuum's efficiency and effectiveness). Failure to change prefilters may damage the vacuum motor and will also shorten the service life of the HEPA filter, which is far more expensive than the prefilters.

### Wet-Dry HEPA Vacuums

Wet-dry HEPA vacuums are equipped with a special shut-off float switch to protect the electrical motor and the HEPA filter from water contact. Some hazard control contractors have found these vacuums to be particularly effective in meeting clearance standards and in avoiding damage to vacuum equipment.

### C. Emptying the Vacuum

Used filters and vacuumed debris should be handled and disposed of in accordance with guidance provided in Chapter 10. Emptying should be done in the containment area or in a secure

and controlled space off-site (such as at the contractor's facility). The vacuum should be placed on a large sheet of plastic to contain dust and debris released during the opening, emptying and replacement steps. Vacuum users should use extreme caution when opening the vacuum for filter replacement or debris removal to avoid accidental release of accumulated dust into the environment. This may occur, for example, if the vacuum's seal has been broken and the vacuum's bag is disturbed. Operators should wear protective clothing and appropriate respiratory protection when performing this maintenance function

#### **D. Wet Cleaning**

It is recommended that a general all-purpose household cleaner be used for wet cleaning. Cleaners made specifically for lead may also be useful, although one study found that lead specific cleaners performed no better than all-purpose household cleaners, and that no published studies have shown lead-specific cleaners to be more effective than all-purpose cleaners (Lewis, 2006). Cleaning with water alone can also be effective, but detergents and lead-specific cleaners are recommended because they probably keep dust and soil in suspension better than plain water (EPA, 1997a; EPA, 1998). HUD does not recommend trisodium phosphate (TSP). Not only has TSP been banned in some areas because of negative effects on the ecology of aquatic systems, but research indicates that phosphate content is not associated with effectiveness in removing lead-contaminated dust from residential surfaces (EPA, 1997a; EPA, 1998, Lewis, 2006).

Research also indicates that the effort put into the cleaning, i.e., the amount of pressure applied to the surface and the thoroughness of the cleaning, may be more important than the choice of cleaning agent (EPA, 1997a). Note that whenever a wet cleaner is used, a small area of the surface should be tested to make sure that it does not damage the surface or its coloring. If so, another wet cleaner should be used.

Proper procedures for using detergents include the following steps:

##### **Manufacturer's Dilution Instructions**

Users of cleaning agents for leaded dust removal should follow manufacturer's instructions for the proper use of a product, especially the recommended dilution ratio.

##### **Appropriate Cleaning Equipment**

Because a detergent may be used to clean leaded dust from a variety of surfaces, several types of application equipment are needed, including cleaning solution spray bottles, wringer buckets, mops (including several clean mop heads), brushes, and rags. Follow manufacturer's instructions for the equipment used. Using the proper equipment on each surface is essential to the quality of the wet wash process.

##### **Wet Cleaning Procedures**

Some wallpaper surfaces may be damaged by wet washing with detergents. Test a small area first. If it appears that damage will occur, try another detergent, use plain water, or as a last resort clean by repeated vacuuming only.

Use of string mops is recommended for floors. Sponge mops may only push the lead around on the floor, not pick it up. A three-bucket system is recommended with mops (see Figure 14.4). The first bucket contains the cleaning solution, the second includes a mop squeezer, and the third



**FIGURE 14.4** Three-bucket cleaning system.

contains rinse water. Use a clean mop head for rinsing. Three-bucket system is also discussed below under Section V.E, Final Cleaning.

Some experienced contractors have used, instead of the three-bucket mopping system, a “wet, wipe and toss” procedure. This method requires a large quantity of clean rags, which are put into a bucket of detergent and water solution to wet them. The worker pulls a rag from the bucket, wrings it out over the bucket, *wipes* clean an area of about 16 sq. ft., *tosses* the used rag away, pulls another rag, and so on. If the detergent requires rinsing, repeat with clean water. For sills, troughs, counters, shelves, walls and tight floor spaces like behind toilets, the wet wipe and toss method is the best alternative to the mop. Some contractors prefer the method even for large floor areas. A major advantage is that it avoids the potential problem of recontaminating the area by cleaning with dirty water. This method may also use less water than a mop, which can be an advantage for some household areas. The rags are commercially available, disposable cloth scraps or paper products. Cloth rags usually are not cleaned and reused because of the risk of contaminating other laundry (White, 2003). Alternatively, some people use wet-dry HEPA vacuums (see Figure 14.5).

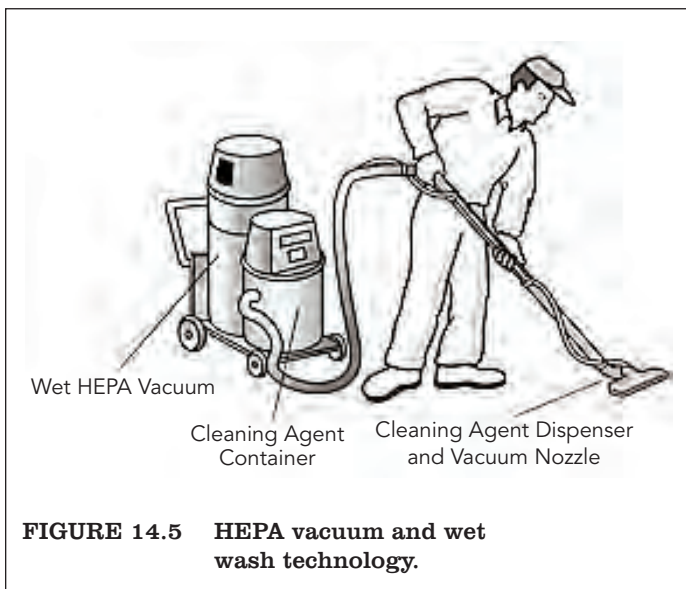

**FIGURE 14.5** HEPA vacuum and wet wash technology.

#### **Changing the Cleaning Mixture**

Many manufacturers of cleaners will indicate the surface area that their cleaning mixture will cover. To avoid recontaminating an area by cleaning it with dirty water, users should follow manufacturer-specified surface area limits. (Note that this issue is largely avoided if the “wet, wipe and toss” method is used, because each rag is used only once.) However, regard-

less of manufacturers’ recommendations, the cleaning mixture should be changed after its use for each room. As a rule of thumb, 5 gallons should be used to clean no more than 1000 square feet. Dirty cleaning mixture should be handled and disposed of in accordance with guidance provided in Chapter 10. Wash water should never be poured onto the ground. It is sometimes filtered, and usually poured down a toilet.

### **IV. Cleaning Procedures Before and During the Work**

The special cleaning procedures to be followed *before and during* a hazard control or renovation project are discussed in chronological order below. Skipping steps in the process may result in failure to meet clearance standards.

### **A. Cleaning Before Work Begins**

Precleaning (i.e., cleaning conducted before lead hazard control or other paint-disturbing work is begun) is necessary only in dwelling units or common areas that are heavily contaminated with lead in dust and paint chips. Precleaning involves the removal of debris and paint chips, followed by vacuuming (see Figure 14.4). These steps may be followed by removal of occupant personal possessions, furniture, or carpeting, depending on the worksite preparation being used (see Chapter 8). If the furniture will not be cleaned, it should be removed from the area and/or covered with protective sheeting prior to beginning the precleaning procedure. Carpeting (including rugs) should always be misted before removal to control the generation of hazardous dust.

It is usually the resident's responsibility to remove most of his or her personal possessions. However, if necessary, owners or project management should be prepared, with necessary boxes, packing materials, and staff, to complete this activity before lead hazard control work begins. As a last resort, the contractor or the maintenance staff may pack any remaining belongings and carefully seal and move the boxes from the work area.

Once the residents' possessions that can be removed from the work area have been removed, the contractor shall ensure that the residents leave the work area and do not return until after clearance (or cleaning verification) has been passed.

Clearance should be conducted after final cleaning but *before* resident's items are moved back in. (See Chapter 15.) Following cleaning and clearance, the contractor should return all resident-owned items to their appropriate places. Leaving these tasks to the contractor or the management may be expensive and inefficient, since the contractor will need to be insured against the possibility that the occupant's belongings may be damaged.

### **B. Ongoing Cleaning During the Job**

On all jobs, it is good practice to regularly clean the work area and the travel pathways used by workers, by removing debris and vacuuming dust during the work shift, in order to keep the areas free of excessive accumulations of dust and/or debris.

For high-dust jobs, when a large amount of paint chips or dust is being generated, continual debris removal and vacuuming of dust during the work day may be necessary to minimize worker exposure and tracking of dust and paint chips from one area to another. Extra attention should be paid to ongoing cleaning so that daily clean-up goes quickly.

Research conducted shortly before the publication of this edition of these *Guidelines* on whether if differences exist between two new and two older methods for removal of lead-contaminated dust from three wood surfaces of varying roughness or texture found that the reduction in lead dust achieved by vacuuming and wet wiping, the traditional method, was somewhat greater and more consistent than the electrostatic dry cloth and wet Swiffer-brand mop, a newer method. (Lewis, 2012) As noted in that paper, the wipe product industry continues to develop products; future cloths may have higher dust reduction efficiencies.

### **C. Daily Cleaning**

Cleaning activity should be scheduled at the end of each work day when all active work has ceased, whether or not this is a regulatory requirement for the particular job. Sufficient time should be allowed for a thorough and complete cleaning, usually about 30 minutes to an hour, less if cleaning has been done throughout the work shift. (If work is being done in multiple shifts, it is recommended

that there be a cleanup at the end of each shift.) Daily cleaning helps achieve clearance dust-lead levels by minimizing problems that may otherwise occur during final cleaning, and it limits worker exposures. Daily cleaning can be skipped within vacant buildings. Daily cleaning is essential when occupants will return in the evening to occupy spaces outside the containment area. Under no circumstances should dust or debris from the project, or protective sheeting be left outside overnight, even if the dwelling is vacant. (Storing bagged dust and debris from the project, and protective sheeting in secure containers outside is permissible.) Daily cleaning should consist of:

- ◆ Wrapping or bagging dust and debris from the project, and storing it in a secure area
- ◆ Vacuuming protective sheeting on floors and furnishings
- ◆ Vacuuming other horizontal surfaces
- ◆ Vacuuming and wet cleaning floors of hallways and rooms used as pathways by workers to travel outside the work area, if such spaces are accessible to residents during non-work hours
- ◆ Cleanup of exterior debris and paint chips, and removal of exterior protective sheeting
- ◆ Patching and repairing protective sheeting
- ◆ Putting any protective sheeting that is removed in a secure place

### 1. Large Debris

Large demolition-type debris (e.g., doors, windows, trim) should be wrapped in heavy duty (6-mil plastic or similar sheeting that will resist puncture), sealed with tape, and moved to a secure area on the property designated for waste storage. All sharp corners, edges, and nails should be hammered down to prevent injury and minimize the tearing of plastic. It is not necessary to wrap each individual piece of debris in plastic if the entire load can be wrapped. A secure area either outside or inside the property should be designated as a temporary waste-storage area. Covered, secured, and labeled dumpsters placed on or near the property may be used. (See Chapter 10.)

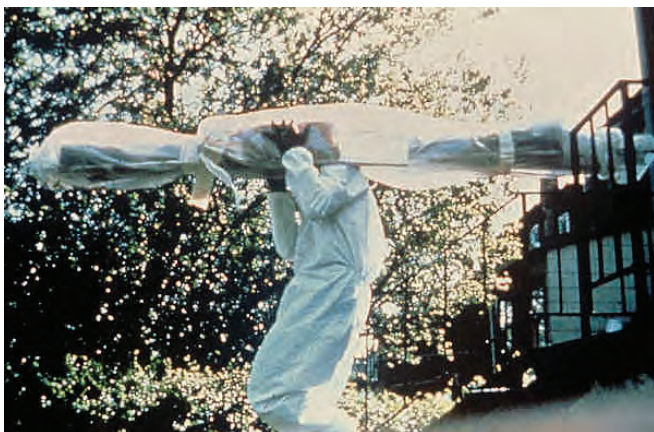

**FIGURE 14.6** Removing large debris.

### 2. Dust and Small Debris

Dust and small debris should be vacuumed and wet wiped or mopped, or, alternatively, after being misted with water, it should be swept up, collected, and disposed of properly. The swept debris should be placed in heavy duty (double 4-mil or single 6-mil polyethylene plastic bags or equivalent), properly sealed, and moved to the designated trash storage area. Trash bags should not be overloaded, as overloaded bags may rupture or puncture during handling and transport.

### 3. Exterior Cleaning

Exterior and interior areas potentially affected by exterior lead hazard control or other paint-disturbing work should

be protected with a containment system (see Chapter 8). Because weather can adversely affect the efficacy of exterior containment, the protective sheeting on the ground should be removed at the end of each work day. On a daily basis, as well as during final cleaning, the immediate exterior area should be examined visually to ensure that no debris has escaped containment. Any such debris should be raked or vacuumed and placed in single 6-mil or double 4-mil plastic bags, which should then be sealed and stored along with other contaminated debris (see Figure 14.7). Vacuuming is appropriate for hard exterior surfaces, but not for soil.

#### 4. Worker Protection Measures

Worker protection measures are discussed in Chapter 9. Studies indicate that during daily cleaning activities, especially while sweeping, lead hazard control workers may be exposed to high levels of airborne dust. When appropriate, workers should wear protective clothing and equipment respiratory protection.

#### 5. Maintaining Containment

The integrity of the protective sheeting used in a lead hazard control project should be maintained. During their daily cleaning activities, workers should monitor the sheeting and immediately repair any holes or rips with durable sheeting (e.g., 6-mil polyethylene) and duct tape.



**FIGURE 14.7** Exterior clean up.

## V. Final Cleaning Procedures

Before treated surfaces can be painted or sealed, final cleaning should be completed. Because airborne dust requires time to settle, the final cleaning process should start no sooner than 1 hour after active lead hazard control or other paint-disturbing work has ceased in the room.

### A. Decontamination of Workers, Supplies and Equipment

Decontamination is necessary to ensure that worker's families, other workers, and subsequent properties do not become contaminated. Specific procedures for proper decontamination of equipment, tools and materials prior to their removal from containment areas should be implemented, as described below and in Chapter 9.

Work clothing, work shoes, and tools should not be placed in a worker's automobile unless they have been laundered, cleaned, or placed in sealed bags. All vacuums and tools that were used should be wiped using rags wetted with detergent solution. In addition, workers should dispose of the rags.

Consumable/disposable supplies, such as mop heads and rags, should be replaced after each dwelling is completed. Using a contaminated mop head can be a major impediment to achieving clearance. Soiled items should be handled and disposed of in accordance with guidance provided in Chapter 10.



**FIGURE 14.8** Vacuuming the floor containment.

Durable equipment, such as power and hand tools, generators, and vehicles, should be cleaned prior to their removal from the site. The cleaning should consist of a thorough vacuuming followed by wet wiping.

### **B. Cleaning and Removal of Protective Sheeting**

Protective sheeting should be cleaned before being removed. This minimizes the generation of airborne dust and/or spillage of dust and debris while the sheeting is being folded up and bagged. Remove large debris as described above in Section IV.C.1. Clean dust and small debris by vacuuming and wet wiping or mopping (see Figure 14.8). Remove upper-level sheeting, such as that on cabinets and counters, first, after it has been cleaned. When removing sheeting, it should be carefully rolled or folded up so that the more-contaminated side is inward. Next, remove sheeting from the floor. All protective sheeting should be folded carefully from the corners/ends to the middle to trap any remaining dust.

Protective sheeting used to isolate work areas from other spaces should remain in place until after the cleaning and removal of other sheeting. These should then be vacuumed, wet-wiped, and removed last.

Removed sheeting should be placed into double 4-mil or single 6-mil plastic bags, or plastic bags with equivalent (or better) performance characteristics, which are sealed and removed from the premises. As with daily cleanings, this removal process usually requires workers to use protective clothing and respiratory protection, especially for high-dust jobs.

### **C. Vacuuming and Wet Cleaning**

After the protective sheeting has been removed, the entire area should be cleaned, using the combination of vacuuming and wet cleaning recommended below. The area to be cleaned is the area that will be subject to the clearance examination, including all rooms, hallways, stairways, elevators, etc. used by workers as passageways to and from the work area, plus areas used to store tools and bagged or packaged debris from the work. (See Section IV.A of Chapter 15 regarding the determination of the clearance area.) Porches, sidewalks, driveways, and other hard exterior surfaces should be vacuumed if exterior hazard control or other paint-disturbing work was conducted, or if debris was stored or dropped on such surfaces.

Interior cleaning for high-dust jobs should begin on the ceilings and end on the floors (following the catch phrase “ceiling to floor and out the door”) For low-dust jobs, it is not necessary to clean ceilings and walls unless paint-disturbing work has been conducted on those surfaces. (See Chapter 8 for a description of low-dust and high-dust jobs.) Cleaning should be sequenced to avoid passing through rooms already cleaned, with the dwellings’ entryway cleaned last.

Surfaces frequently cleaned include ceilings, walls, floors, window panes and mullions, interior window sills, window troughs, exterior window sills, doors, heating, ventilation, and air conditioning (HVAC) equipment (heating diffusers, radiators, pipes, vents), fixtures of any kind (light, bathroom, kitchen), built-in cabinets, and appliances.

Surfaces such as porous concrete, old uncoated, worn and porous hardwood floors, and areas such as corners of rooms and window troughs pose especially difficult cleaning challenges. Porous concrete and corners of rooms normally require additional vacuuming to achieve an acceptable level of cleanliness.

After a high-dust job, the recommended first cleaning step is vacuuming to pick up large amounts of dust and small debris. All surfaces should be vacuumed: ceilings, walls, windows, doors, shelves, floors, etc. Research indicates that walls and ceilings retain leaded-dust after lead hazard control projects (Dixon, 2004). Vacuuming is especially important if some of the surfaces are rough. The second step is a wet cleaning, using the wipe or mopping method, as described above in Section III.D. Wet cleaning is probably the most effective method of picking up small particles of lead-dust (California Dept. of Health Services, 2004). (Be sure to vacuum and wet-wipe window troughs, because they are tested for dust-lead by the clearance examiner.) Vacuuming and wet-cleaning once should be sufficient if the surfaces are smooth, but it is recommended that rough surfaces be vacuumed a second time, after the wet-cleaned surface has dried, to increase the likelihood of achieving clearance. As an alternative to the second vacuum pass, some contractors have found that better clearance results on rough surfaces are achieved by thoroughly wiping by hand the wet-cleaned surface until it is dry, using disposable towels (Rupp, 2003). The amount of wiping needed to clean a surface may depend on how soiled it is, as well as its smoothness or roughness.

After low-dust jobs, the first pass with the vacuum is usually not necessary, especially if the surface is smooth. It is often effective to begin with a wet cleaning. But if there is a substantial amount of dust or small debris on the surfaces to be cleaned, begin with the vacuum and then go to the wet cleaning. This will make the wet cleaning more efficient. Vacuuming following the wet cleaning is recommended for rough surfaces but may not be necessary for smooth surfaces. It is generally not necessary to clean ceilings and walls after low-dust jobs, unless paint disturbing work has been conducted on those surfaces. Remember to clean the window troughs. These recommendations are summarized in Table 14.1.

**Table 14.1 Summary Guidance on Cleaning Methods by Dustiness of Work and Condition of the Surface.**

Conditions	Cleaning Procedure	Surfaces
High-dust job, with some rough surfaces	Vacuum, wet clean, vacuum (after surface is dry)	All surfaces, including ceilings, walls, and window troughs.
High-dust job, with all smooth surfaces	Vacuum, wet clean	
Low-dust job, with some rough surfaces	Vacuum (optional, depends on amount of dust), wet clean, vacuum (after surface is dry)	All surfaces except ceilings and walls, unless those surfaces have been treated.
Low-dust job, with all smooth surfaces	Vacuum (optional, depends on amount of dust), wet clean	



**FIGURE 14.9** Inspecting for completeness of the work performed.

#### **D. Supervisor's Preliminary Visual Inspection**

After the cleaning is completed, the supervisor should visually evaluate the entire area subject to clearance (including work areas, worker passageways and storage areas) to ensure that all work has been completed and all visible dust and debris has been removed (see Figure 14.9). The supervisor's preliminary inspection does not replace the independent visual assessment and dust testing conducted by the clearance examiner. If the clearance examiner's visual assessment results are unsatisfactory, dust testing is postponed until identified surfaces are re-cleaned and/or retreated. This process makes it cost effective to have the supervisor perform a preliminary visual inspection.

#### **E Surface Painting or Sealing of Non-Floor Surfaces**

The next step of preparing for clearance (or cleaning verification) is painting or otherwise sealing all treated surfaces except floors. Surfaces, including walls, ceilings, and woodwork, should be coated with an appropriate primer and repainted. Surfaces enclosed with vinyl, aluminum coil stock, and other materials traditionally not painted are exempt from the painting provision.

Painters should use the following lead-safe work practices:

- ◆ Using "drop cloths," which should be disposable, impermeable sheeting – not cloth,
- ◆ Cleaning their work tools before bringing them into the clearance area, and
- ◆ Ensuring no dust is tracked in from outside the clearance area.

#### **F. Sealing Floors**

The next step before clearance is to seal all hard-surface floors that do not already have an intact, nonporous coating. Sealed surfaces are easier for residents to clean and maintain over time than those that are not sealed. Wooden floors should be sealed with clear polyurethane or painted with deck enamel or durable paint. Vinyl tile, linoleum, and other similar floors should be sealed with an appropriate floor wax (or equivalent product). Concrete floors should be sealed with a concrete sealer or other type of concrete deck enamel. However, if these floors are already covered by an effective coat of sealant, it may be possible to skip this step.

As an alternative to sealing, floors may be covered with new vinyl tile, sheet vinyl, linoleum flooring, or the equivalent to create a more permanent cleanable surface. New surfaces should be cleaned with a cleaning solution that is appropriate for that type of surface.

Workers applying floor sealants or coverings should take care to wipe clean tools brought into the work area and to avoid tracking in dust from outside the clearance area.

#### **G. Final Wet Cleaning, EPA Cleaning Verification, and Possible Pre-Clearance Dust Testing**

Even if painters and floor covering workers use lead-safe work practices, lead-contaminated dust may still migrate into previously cleaned areas. Therefore, it is recommended that the final step before the clearance examination is to wet clean all horizontal surfaces one more time (see Figures 14.10 through 14.13).

**HEPA vacuum all surfaces**

Start at the end farthest from the main entrance/exit. As you vacuum, move towards the main exit and finish there.



Begin at the top of each room and work down. For example, start with the top shelves, the top of the wood work, and so on, and work down to the floor. Do every inch of the window, especially the window trough.



Courtesy: Alice Hamilton Occupational Health Center

**FIGURE 14.10** The HEPA Vacuum-Wet Wash-HEPA Vacuum Cycle Helps Meet Clearance Standards.

Wash all surfaces in the work area with suitable detergents, including areas that had been covered with plastic. Some wallpaper should only be HEPA vacuumed, since it may be damaged by the detergent.



Wet Mop Floor



Don't Dry Sweep

**FIGURE 14.11** Wet Cycle Requires Washing All Surfaces with Suitable Detergents.

**Use the 3-Bucket System**

**To wash:** Use string mops and mop buckets with wringers. (Some experts say NEVER use a sponge mop on the floor. Sponge mops may only push the lead around on the floor, not remove it.)

Dip the string mophead in the detergent wash in bucket #1. Mop the floor.



Squeeze out the mophead in empty bucket #2. Return to bucket #1 for more detergent solutions and continue mopping. Repeat.



Use the third bucket for rinsing the floor.

**FIGURE 14.12** Use a Three-Bucket System and Then HEPA Vacuum Again to Minimize Recontamination.



**HEPA vacuum all surfaces a final time**

HEPA vacuum all surfaces in the work area, including areas that had been covered with plastic.

Starting at the far end, work towards the decontamination area. Begin with ceilings or the top of the walls and work down, cleaning the floors last. Do every inch of the windows, especially the troughs. Use the corner tool to clean where the floor meets the baseboard and all the cracks in the floor boards. Use the brush tool for the walls. Move slowly and carefully to get all the dust.

**FIGURE 14.13** HEPA vacuum all surfaces a final time.

Under EPA's Renovation, Repair and Painting rule, after the renovation has been completed, the firm must clean the work area until no dust, debris or residue remains (see Appendix 6). The post-renovation cleaning verification requirements must be performed by a certified renovator. If the certified renovator directs the other workers to perform the work practices, the certified renovator must be at the work site during cleaning of the work site. For more information on EPA's RRP rule and the cleaning it requires, see [www.epa.gov/lead/pubs/renovation.htm](http://www.epa.gov/lead/pubs/renovation.htm).

At this point in the process, supervisors of work for which achievement of clearance is known to be difficult may wish to consider preliminary dust testing before requesting the clearance examination. Factors that tend to be associated with clearance failure are (1) high levels of lead in dust and paint before the work began, (2) hard floor and window surfaces that are not smooth and cleanable, and (3) high-dust work in rooms from which furniture has not been removed (NCHH, 2004).

Methods exist for reliably screening wipe samples on-site instead of in a fixed laboratory. These include portable X-ray fluorescence (XRF) analysis and anodic stripping voltammetry (ASV) (Ashley 2001; EPA, 2002b; Clark, 2002) or potentiometric stripping analysis (PSA). These methods may provide testing results much more quickly than fixed laboratory analysis, because transportation of samples is not necessary and handling time is reduced. Note that analysis of samples taken from target housing of pre-1978 child-occupied facilities must be conducted by a laboratory, whether fixed-site or mobile, recognized by the Environmental Protection Agency (EPA) under its National Lead Laboratory Accreditation Program (NLLAP) (<http://www.epa.gov/lead/pubs/nllap.htm>).

Any person who is trained and otherwise qualified to operate the XRF instrument or use the ASV method may use these methods to conduct *preliminary* dust testing to determine whether the clearance area is clean and ready for the clearance examination. A person conducting a preliminary screen does not have to be a technician working for an NLLAP-recognized laboratory; the sample may be collected by the contractor or the owner, and given to the laboratory for analysis. Owners and contractors may wish to use such screening tests to minimize the likelihood of clearance failure. Federal and State regulations on the use of devices with radioactive elements (i.e., some XRF analyzers) must be observed (see Chapter 7, section VII.A).

## H. Clearance

The clearance examination should take place more than 1 hour after the final cleaning. This ensures that any airborne lead particles stirred up by the cleaning have settled. Clearance is usually performed after the sealant is applied to the floor. See Chapter 15 for information on clearance examination procedures. For cleaning verification, a waiting period is not required for the initial wipe, nor after the first failed wipe, but a 1-hour waiting period is required after the second failed wipe before the work area is released from the project.

## I. Recleaning After Clearance Failure

If the area fails the clearance examiner's visual assessment or clearance dust sampling tests, all surfaces represented by the failing clearance dust wipe samples must be recleaned. Failure is an indication that the cleaning has not been successful. If the surfaces are smooth, a wet wash should be used. If the surfaces are rough, a vacuum, wet-cleaning, vacuum cycle is recommended. If the failing surfaces include carpeting, the decision must be made whether to try to clean the carpet or to dispose of it. See Section V.B.2 of Chapter 11 for guidance. Care should be exercised during the recleaning of "failed" surfaces or components to avoid recontaminating "cleared" surfaces or components.

## References

Ashley, 2001. Ashley, K., Wise, T.J., Mercado, W., Parry D.B., Ultrasonic extraction and field-portable anodic stripping voltammetric measurement of lead in dust wipe sample. *Journal of Hazardous Materials*, 83: 41-50, 2001.

California Department of Health Services, 2004. Public Health Institute for California Department of Health Services, Childhood Lead Poisoning Prevention Branch and Environmental Health Laboratory Branch, "Evaluation of Household Vacuum Cleaners in the Removal of Settled Lead Dust from Hard Surface Floors," Final Report to U.S. Department of Housing and Urban Development, 2004.

CMHC, 1992. Canada Mortgage and Housing Corporation, Saskatchewan Research Council Report, *Effectiveness of Cleanup Techniques for Leaded Paint Dust*, Saskatoon, Saskatchewan, Canada (also see Figley, 1994). (<http://www.cmhc-schl.gc.ca/publications/en/rh-pr/tech/92-203.pdf>)

Clark, 2002. Clark, C.S., "Development of a Rapid On-Site Method for the Analysis of Dust Wipes Using Field Portable X-Ray Fluorescence," prepared for the U.S. Department of Housing and Urban Development, January, 2002.

Dixon, 2004. Sherry Dixon, Jonathan Wilson, Paul Succop, Mei Chen, Warren Galke, William Menrath, and C. Clark, "Residential Dust Lead Loading Immediately After Intervention in the HUD Lead Hazard Control Grant Program," *Journal of Occupational and Environmental Hygiene*, 1: 716 – 724.

EPA, 1997a. U.S. Environmental Protection Agency, *Laboratory Study of Lead-Cleaning Efficacy*, March 1997 (EPA 747-R-97-002).

EPA, 1998. U.S. Environmental Protection Agency, *Lead-Cleaning Efficacy Follow-Up Study*, October 1998 (EPA 747-R-98-008).

EPA, 2002b. U.S. Environmental Protection Agency, The Environmental Technology Verification Program (ETV), Verification Statements EPA-VS-SCM-50, 51, 52, 53 and 54. Prepared by Oak Ridge National Laboratory, Oak Ridge, Tennessee, August, 2002.

Ewers, 1994. Ewers, L., S. Clark, W. Menrath, P. Succop, and R. Bornschein, "Clean-Up of Lead in Household Carpet and Floor Dust," *Journal of the American Industrial Hygiene Association*, 55(7):650-7, July, 1994.

Lewis, 2006. Roger D. Lewis, Sridhar Condoor, Joe Batek, Kee Hean Ong, Denis Backer, David Sterling, Jeff Siria, John J. Chen, and Peter Ashley, "Removal of Lead Contaminated Dusts from Hard Surfaces," *Environ. Sci. Technol.*, 40, 590 -594, 2006. <http://pubs.acs.org/doi/abs/10.1021/es050803s>.

Lewis, 2012. Lewis R.D., Ong, K.H., Emo, B, Kennedy, J., Brown, C.A., Condoor, S. and Thummalakunta, L. Do New Wipe Materials Outperform Traditional Lead Dust Cleaning Methods? *Journal of Occupational and Environmental Hygiene*, 9:8 524-533, August 2012. <http://www.tandfonline.com/doi/abs/10.1080/15459624.2012.695975>

NCHH, 2004. National Center for Healthy Housing, and University of Cincinnati Department of Environmental Health, *Evaluation of the HUD Lead-Based Paint Hazard Control Grant Program: Final Report*, prepared for the U.S. Department of Housing and Urban Development, Washington, DC, May 1, 2004.

Rich, 2002. Rich, David Q., G.G. Rhoads, L. Yiin, J. Zhang, Z. Bai, J.L. Adgate, P.J. Ashley and P.L. Liroy, "Comparison of Home Lead Dust Reduction Techniques on Hard Surfaces: The New Jersey Assessment of Cleaning Techniques Trial," *Environmental Health Perspectives*, 110(9): 889-893, September, 2002.

Rupp, 2003. Rupp, R. and R. Zatzke, "Comments on Proposed Revisions to Chapter 14 of the HUD *Guidelines*, Unpublished memorandum, May 8, 2003.

White, 2003. White, K. and G. Dewalt, Unpublished comments on proposed revisions to Chapter 14 of the HUD *Guidelines*, May 2003.

Yiin, 2002. Yiin, Lih-Ming, F.F. Rhoads, D.Q. Rich, J. Zhang, Z. Bai, J.L. Adgate, P.J. Ashley and P.J. Liroy, "Comparison of Techniques to Reduce Residential Lead Dust on Carpet and Upholstery: The New Jersey Assessment of Cleaning Techniques Trial," *Environmental Health Perspectives*, 110(12): 1-5, December, 2002.

# **SECTION 8**

## **Sample Hazard Communication Plan**

**29 CFR 1910.1200 - Hazard Communication Standard**

**OSHA 3111 - Hazard Communication Guidelines for  
Compliance**

# WRITTEN HAZARD COMMUNICATION PROGRAM

## General Information

In order to comply with the Occupational Safety and Health Regulations, 29 CFR 1910.1200 Hazard Communication Standard, the following written Hazard Communication Program has been established for:

\_\_\_\_\_ *Name of Company* \_\_\_\_\_

All division and sections of the company are included with this program. The written program will be available in the \_\_\_\_\_ *Location* \_\_\_\_\_ for review by any interested employee.

\_\_\_\_\_ *Name of Company* \_\_\_\_\_ will meet the requirements of this rule as follows:

### 1. Hazard Communication

\_\_\_\_\_ *Name of Company* \_\_\_\_\_ will rely on the Chemical Manufacturer's Material Safety Data Sheet (MSDS) for the hazard determination.

(Note: Companies which manufacture hazardous chemicals or materials must develop a MSDS and must modify the above statement)

### 2. Container Labeling

The following labeling systems will be used at \_\_\_\_\_ *Name of Company* \_\_\_\_\_

- Chemical Manufacturer's Labeling System
- HMIS (if used)
- Any other type of system used such as color coding, etc.

The \_\_\_\_\_ *person/position* \_\_\_\_\_ will verify that all containers received for use will:

- Be clearly labeled as to the contents
- Note the appropriate hazard warning
- List the Name and Address of the manufacturer

It is the policy of this company that no container will be released for use until the above data is verified.

The supervisor \_\_\_\_\_ *Name* \_\_\_\_\_ in each section will ensure that all secondary containers are labeled with either an extra copy of the original manufacturer's label or with the generic labels which have a block for identity and blocks for the hazard warning. In addition, the area supervisor will ensure that all hazardous chemicals in their area remain properly labeled. For help with labeling, please see our safety and health officer

\_\_\_\_\_ *Name* \_\_\_\_\_

### 3. Material Safety Data Sheets (MSDS)

Copies of MSDSs for all hazardous chemicals to which employees of this company may be exposed will be kept in \_\_\_\_\_ *Location* \_\_\_\_\_

MSDSs will be available to all employees in their work area for review during each work shift. If MSDSs are not available or new chemicals in use do not have MSDSs, please contact \_\_\_\_\_ *person/position* \_\_\_\_\_ immediately.

\_\_\_\_\_ *Person/Position* \_\_\_\_\_ is responsible for ensuring that all MSDSs have been received and are current. If a MSDS is not received with the first shipment of a hazardous chemical, the following methods will be used to obtain a MSDS:

- A letter requesting a MSDS will be sent to the manufacturer or distributor of the hazardous chemical. (A copy of the letter will be kept on file)
- A phone call will be made to the manufacturer or distributor requesting a MSDS. (A log of all phone calls requesting MSDS will be kept.)

### 4. Employee Training and Information

\_\_\_\_\_ *Person/Position* \_\_\_\_\_ is responsible for employee training.

Prior to starting work each new employee (or transferring employee) of:

\_\_\_\_\_ *Name of Company* \_\_\_\_\_

will attend a health and safety orientation and will receive information and training on the following:

- An overview of the requirements contained in the Hazard Communication Rules
- Chemical present in their workplace operations
- Location and availability of our written hazard program
- Physical and health effects of the hazardous chemicals
- Methods and observation techniques used to determine the presence or release of hazardous chemicals in the work area
- How to lessen or prevent exposure to these hazardous chemicals through usage of control/work practices and personal protective equipment
- Steps the company has taken to lessen or prevent exposure to these chemicals
- Safety emergency procedures to follow if they are exposed to these chemicals
- How to read labels and review MSDSs to obtain appropriate hazard information

After attending the training class, each employee will sign a form to verify that they attended the training, received our written materials, and understand this company's policies on Hazard Communication. (Optional Item)

Prior to a new hazardous chemical being introduced into any section of this company, each employee of the section will be given information as outlined above.

Person/Position is responsible for ensuring that MSDSs on the new chemical(s) are available.

### 5. List of Hazardous Chemicals

The following is a list of all known Hazardous Chemicals used by employees of Name of Company. Further information on each noted chemical can be obtained by reviewing Material Safety Data Sheets located in Location

Hazardous Chemicals	Work Process/Location

(Note: the Hazard Communication rules only require a list of all hazardous chemicals: however, it is felt that identifying the location and possibly the process will aid the employer in carrying out the full program)

### 6. Hazardous Non-Routine Tasks

Periodically, employees are required to perform hazardous non-routine tasks. Prior to starting work on such projects, each affected employee will be given information by his section supervisor about hazardous chemicals to which they may be exposed during such activity.

This information will include:

- Specific chemical hazards
- Protective/safety measures the employee can take
- Measures the company has taken to lessen the hazards including ventilation, respirators, presence of another employee and emergency procedures

Examples of non-routine tasks performed by employees of this company:

Task Hazardous	Chemical

### 7. Chemicals in Unlabeled Pipes

Work activities are often performed by employees in areas where chemicals are transferred through unlabeled pipes. Prior to starting work in these areas, the employee shall contact Person/Position for information regarding:

- The chemical in the pipes
- Potential Hazards
- Safety precautions which should be taken

### 8. Informing Contractors

It is the responsibility of Person/Position/Department/etc. to provide contractors (with employees) the following information:

- Hazardous chemicals to which they may be exposed while on the job site including availability of material safety data sheets
- Precautions the employees may take to lessen the possibility of exposure by usage of appropriate protective measures
- An explanation of the labeling system

- **Part Number:** 1910
  - **Part Number Title:** Occupational Safety and Health Standards
  - **Subpart:** 1910 Subpart Z
  - **Subpart Title:** Toxic and Hazardous Substances
  - **Standard Number:** 1910.1200
  - **Title:** Hazard Communication.
  - **Appendix:** A; B; C; D; E; F
  - **GPO Source:** e-CFR
- 

**Note:** The following text for 1910.1200 has been updated to align with the UN Globally Harmonized System of Classification and Labelling of Chemicals (GHS), Revision 3, issued in the Federal Register, March 26, 2012. This rule became effective May 25, 2012.

Also, the Hazard Communication page, on OSHA.gov, includes downloadable versions of the revised 1910.1200 Final Rule and appendices, updated to align with the GHS; a comparison of the Hazard Communication Standard, issued in 1994 (HazCom 1994), with the revised Hazard Communication Final Rule issued in 2012 (HazCom 2012); frequently asked questions on the revisions; and new guidance materials on the revisions. The page also contains the full regulatory text and appendices of HazCom 1994.

1910.1200(a)

*Purpose.*

1910.1200(a)(1)

The purpose of this section is to ensure that the hazards of all chemicals produced or imported are classified, and that information concerning the classified hazards is transmitted to employers and employees. The requirements of this section are intended to be consistent with the provisions of the United Nations Globally Harmonized System of Classification and Labelling of Chemicals (GHS), Revision 3. The transmittal of information is to be accomplished by means of comprehensive hazard communication programs, which are to include container labeling and other forms of warning, safety data sheets and employee training.

1910.1200(a)(2)

This occupational safety and health standard is intended to address comprehensively the issue of classifying the potential hazards of chemicals, and communicating information concerning hazards and appropriate protective measures to employees, and to preempt any legislative or regulatory enactments of a state, or political subdivision of a state, pertaining to this subject. Classifying the potential hazards of chemicals and communicating information concerning hazards and appropriate protective measures to employees, may include, for example, but is not limited to, provisions for: developing and maintaining a written hazard communication program for the workplace, including lists of hazardous chemicals present; labeling of containers of chemicals in the workplace, as well as of containers of chemicals being shipped to other workplaces; preparation and distribution of safety

data sheets to employees and downstream employers; and development and implementation of employee training programs regarding hazards of chemicals and protective measures. Under section 18 of the Act, no state or political subdivision of a state may adopt or enforce any requirement relating to the issue addressed by this Federal standard, except pursuant to a Federally-approved state plan.

1910.1200(b)

*Scope and application.*

1910.1200(b)(1)

This section requires chemical manufacturers or importers to classify the hazards of chemicals which they produce or import, and all employers to provide information to their employees about the hazardous chemicals to which they are exposed, by means of a hazard communication program, labels and other forms of warning, safety data sheets, and information and training. In addition, this section requires distributors to transmit the required information to employers. (Employers who do not produce or import chemicals need only focus on those parts of this rule that deal with establishing a workplace program and communicating information to their workers.)

1910.1200(b)(2)

This section applies to any chemical which is known to be present in the workplace in such a manner that employees may be exposed under normal conditions of use or in a foreseeable emergency.

1910.1200(b)(3)

This section applies to laboratories only as follows:

1910.1200(b)(3)(i)

Employers shall ensure that labels on incoming containers of hazardous chemicals are not removed or defaced;

1910.1200(b)(3)(ii)

Employers shall maintain any safety data sheets that are received with incoming shipments of hazardous chemicals, and ensure that they are readily accessible during each workshift to laboratory employees when they are in their work areas;

1910.1200(b)(3)(iii)

Employers shall ensure that laboratory employees are provided information and training in accordance with paragraph (h) of this section, except for the location and availability of the written hazard communication program under paragraph (h)(2)(iii) of this section; and,

1910.1200(b)(3)(iv)

Laboratory employers that ship hazardous chemicals are considered to be either a chemical manufacturer or a distributor under this rule, and thus must ensure that any containers of hazardous chemicals leaving the laboratory are labeled in accordance with paragraph (f) of this section, and that a safety data sheet is provided to distributors and other employers in accordance with paragraphs (g)(6) and (g)(7) of this section.

1910.1200(b)(4)

In work operations where employees only handle chemicals in sealed containers which are not opened under normal conditions of use (such as are found in marine cargo handling, warehousing, or retail sales), this section applies to these operations only as follows:

1910.1200(b)(4)(i)

Employers shall ensure that labels on incoming containers of hazardous chemicals are not removed or defaced;

1910.1200(b)(4)(ii)

Employers shall maintain copies of any safety data sheets that are received with incoming shipments of the sealed containers of hazardous chemicals, shall obtain a safety data sheet as soon

as possible for sealed containers of hazardous chemicals received without a safety data sheet if an employee requests the safety data sheet, and shall ensure that the safety data sheets are readily accessible during each work shift to employees when they are in their work area(s); and,  
1910.1200(b)(4)(iii)

Employers shall ensure that employees are provided with information and training in accordance with paragraph (h) of this section (except for the location and availability of the written hazard communication program under paragraph (h)(2)(iii) of this section), to the extent necessary to protect them in the event of a spill or leak of a hazardous chemical from a sealed container.  
1910.1200(b)(5)

This section does not require labeling of the following chemicals:

1910.1200(b)(5)(i)

Any pesticide as such term is defined in the Federal Insecticide, Fungicide, and Rodenticide Act (7 U.S.C. 136 *et seq.*), when subject to the labeling requirements of that Act and labeling regulations issued under that Act by the Environmental Protection Agency;

1910.1200(b)(5)(ii)

Any chemical substance or mixture as such terms are defined in the Toxic Substances Control Act (15 U.S.C. 2601 *et seq.*), when subject to the labeling requirements of that Act and labeling regulations issued under that Act by the Environmental Protection Agency;

1910.1200(b)(5)(iii)

Any food, food additive, color additive, drug, cosmetic, or medical or veterinary device or product, including materials intended for use as ingredients in such products (*e.g.* flavors and fragrances), as such terms are defined in the Federal Food, Drug, and Cosmetic Act (21 U.S.C. 301 *et seq.*) or the Virus-Serum-Toxin Act of 1913 (21 U.S.C. 151 *et seq.*), and regulations issued under those Acts, when they are subject to the labeling requirements under those Acts by either the Food and Drug Administration or the Department of Agriculture;

1910.1200(b)(5)(iv)

Any distilled spirits (beverage alcohols), wine, or malt beverage intended for nonindustrial use, as such terms are defined in the Federal Alcohol Administration Act (27 U.S.C. 201 *et seq.*) and regulations issued under that Act, when subject to the labeling requirements of that Act and labeling regulations issued under that Act by the Bureau of Alcohol, Tobacco, Firearms and Explosives;

1910.1200(b)(5)(v)

Any consumer product or hazardous substance as those terms are defined in the Consumer Product Safety Act (15 U.S.C. 2051 *et seq.*) and Federal Hazardous Substances Act (15 U.S.C. 1261 *et seq.*) respectively, when subject to a consumer product safety standard or labeling requirement of those Acts, or regulations issued under those Acts by the Consumer Product Safety Commission; and,

1910.1200(b)(5)(vi)

Agricultural or vegetable seed treated with pesticides and labeled in accordance with the Federal Seed Act (7 U.S.C. 1551 *et seq.*) and the labeling regulations issued under that Act by the Department of Agriculture.

1910.1200(b)(6)

This section does not apply to:

1910.1200(b)(6)(i)

Any hazardous waste as such term is defined by the Solid Waste Disposal Act, as amended by the Resource Conservation and Recovery Act of 1976, as amended (42 U.S.C. 6901 *et seq.*), when subject to regulations issued under that Act by the Environmental Protection Agency;

1910.1200(b)(6)(ii)

Any hazardous substance as such term is defined by the Comprehensive Environmental Response, Compensation and Liability Act (CERCLA) (42 U.S.C. 9601 *et seq.*) when the hazardous substance is the focus of remedial or removal action being conducted under CERCLA in accordance with Environmental Protection Agency regulations.

1910.1200(b)(6)(iii)

Tobacco or tobacco products;

1910.1200(b)(6)(iv)

Wood or wood products, including lumber which will not be processed, where the chemical manufacturer or importer can establish that the only hazard they pose to employees is the potential for flammability or combustibility (wood or wood products which have been treated with a hazardous chemical covered by this standard, and wood which may be subsequently sawed or cut, generating dust, are not exempted);

1910.1200(b)(6)(v)

Articles (as that term is defined in paragraph (c) of this section);

1910.1200(b)(6)(vi)

Food or alcoholic beverages which are sold, used, or prepared in a retail establishment (such as a grocery store, restaurant, or drinking place), and foods intended for personal consumption by employees while in the workplace;

1910.1200(b)(6)(vii)

Any drug, as that term is defined in the Federal Food, Drug, and Cosmetic Act (21 U.S.C. 301 *et seq.*), when it is in solid, final form for direct administration to the patient (*e.g.*, tablets or pills); drugs which are packaged by the chemical manufacturer for sale to consumers in a retail establishment (*e.g.*, over-the-counter drugs); and drugs intended for personal consumption by employees while in the workplace (*e.g.*, first aid supplies);

1910.1200(b)(6)(viii)

Cosmetics which are packaged for sale to consumers in a retail establishment, and cosmetics intended for personal consumption by employees while in the workplace;

1910.1200(b)(6)(ix)

Any consumer product or hazardous substance, as those terms are defined in the Consumer Product Safety Act (15 U.S.C. 2051 *et seq.*) and Federal Hazardous Substances Act (15 U.S.C. 1261 *et seq.*) respectively, where the employer can show that it is used in the workplace for the purpose intended by the chemical manufacturer or importer of the product, and the use results in a duration and frequency of exposure which is not greater than the range of exposures that could reasonably be experienced by consumers when used for the purpose intended;

1910.1200(b)(6)(x)

Nuisance particulates where the chemical manufacturer or importer can establish that they do not pose any physical or health hazard covered under this section;

1910.1200(b)(6)(xi)

Ionizing and nonionizing radiation; and,

1910.1200(b)(6)(xii)

Biological hazards.

1910.1200(c)

*Definitions.* *Article* means a manufactured item other than a fluid or particle: (i) which is formed to a specific shape or design during manufacture; (ii) which has end use function(s) dependent in whole or in part upon its shape or design during end use; and (iii) which under normal conditions of use does not release more than very small quantities, *e.g.*, minute or trace amounts of a hazardous chemical (as determined under paragraph (d) of this section), and does not pose a physical hazard

or health risk to employees.

*Assistant Secretary* means the Assistant Secretary of Labor for Occupational Safety and Health, U.S. Department of Labor, or designee.

*Chemical* means any substance, or mixture of substances.

*Chemical manufacturer* means an employer with a workplace where chemical(s) are produced for use or distribution.

*Chemical name* means the scientific designation of a chemical in accordance with the nomenclature system developed by the International Union of Pure and Applied Chemistry (IUPAC) or the Chemical Abstracts Service (CAS) rules of nomenclature, or a name that will clearly identify the chemical for the purpose of conducting a hazard classification.

*Classification* means to identify the relevant data regarding the hazards of a chemical; review those data to ascertain the hazards associated with the chemical; and decide whether the chemical will be classified as hazardous according to the definition of hazardous chemical in this section. In addition, classification for health and physical hazards includes the determination of the degree of hazard, where appropriate, by comparing the data with the criteria for health and physical hazards.

*Commercial account* means an arrangement whereby a retail distributor sells hazardous chemicals to an employer, generally in large quantities over time and/or at costs that are below the regular retail price.

*Common name* means any designation or identification such as code name, code number, trade name, brand name or generic name used to identify a chemical other than by its chemical name.

*Container* means any bag, barrel, bottle, box, can, cylinder, drum, reaction vessel, storage tank, or the like that contains a hazardous chemical. For purposes of this section, pipes or piping systems, and engines, fuel tanks, or other operating systems in a vehicle, are not considered to be containers.

*Designated representative* means any individual or organization to whom an employee gives written authorization to exercise such employee's rights under this section. A recognized or certified collective bargaining agent shall be treated automatically as a designated representative without regard to written employee authorization.

*Director* means the Director, National Institute for Occupational Safety and Health, U.S. Department of Health and Human Services, or designee.

*Distributor* means a business, other than a chemical manufacturer or importer, which supplies hazardous chemicals to other distributors or to employers.

*Employee* means a worker who may be exposed to hazardous chemicals under normal operating conditions or in foreseeable emergencies. Workers such as office workers or bank tellers who encounter hazardous chemicals only in non-routine, isolated instances are not covered.

*Employer* means a person engaged in a business where chemicals are either used, distributed, or are produced for use or distribution, including a contractor or subcontractor.

*Exposure or exposed* means that an employee is subjected in the course of employment to a chemical that is a physical or health hazard, and includes potential ( e.g. accidental or possible) exposure. "Subjected" in terms of health hazards includes any route of entry ( e.g. inhalation, ingestion, skin contact or absorption.)

*Foreseeable emergency* means any potential occurrence such as, but not limited to, equipment failure, rupture of containers, or failure of control equipment which could result in an uncontrolled release of a hazardous chemical into the workplace.

*Hazard category* means the division of criteria within each hazard class, e.g., oral acute toxicity and flammable liquids include four hazard categories. These categories compare hazard severity within a hazard class and should not be taken as a comparison of hazard categories more generally.

*Hazard class* means the nature of the physical or health hazards, e.g., flammable solid, carcinogen, oral acute toxicity.

*Hazard not otherwise classified (HNOC)* means an adverse physical or health effect identified through evaluation of scientific evidence during the classification process that does not meet the specified criteria for the physical and health hazard classes addressed in this section. This does not extend coverage to adverse physical and health effects for which there is a hazard class addressed in this section, but the effect either falls below the cut-off value/concentration limit of the hazard class or is under a GHS hazard category that has not been adopted by OSHA (e.g., acute toxicity Category 5).

*Hazard statement* means a statement assigned to a hazard class and category that describes the nature of the hazard(s) of a chemical, including, where appropriate, the degree of hazard.

*Hazardous chemical* means any chemical which is classified as a physical hazard or a health hazard, a simple asphyxiant, combustible dust, pyrophoric gas, or hazard not otherwise classified.

*Health hazard* means a chemical which is classified as posing one of the following hazardous effects: acute toxicity (any route of exposure); skin corrosion or irritation; serious eye damage or eye irritation; respiratory or skin sensitization; germ cell mutagenicity; carcinogenicity; reproductive toxicity; specific target organ toxicity (single or repeated exposure); or aspiration hazard. The criteria for determining whether a chemical is classified as a health hazard are detailed in Appendix A to 1910.1200Health Hazard Criteria.

*Immediate use* means that the hazardous chemical will be under the control of and used only by the person who transfers it from a labeled container and only within the work shift in which it is transferred.

*Importer* means the first business with employees within the Customs Territory of the United States which receives hazardous chemicals produced in other countries for the purpose of supplying them to distributors or employers within the United States.

*Label* means an appropriate group of written, printed or graphic information elements concerning a hazardous chemical that is affixed to, printed on, or attached to the immediate container of a hazardous chemical, or to the outside packaging.

*Label elements* means the specified pictogram, hazard statement, signal word and precautionary statement for each hazard class and category.

*Mixture* means a combination or a solution composed of two or more substances in which they do not react.

*Physical hazard* means a chemical that is classified as posing one of the following hazardous effects: explosive; flammable (gases, aerosols, liquids, or solids); oxidizer (liquid, solid or gas); self-reactive; pyrophoric (liquid or solid); self-heating; organic peroxide; corrosive to metal; gas under pressure; or in contact with water emits flammable gas. See Appendix B to 1910.1200 Physical Hazard Criteria.

*Pictogram* means a composition that may include a symbol plus other graphic elements, such as a border, background pattern, or color, that is intended to convey specific information about the hazards of a chemical. Eight pictograms are designated under this standard for application to a hazard category.

*Precautionary statement* means a phrase that describes recommended measures that should be taken to minimize or prevent adverse effects resulting from exposure to a hazardous chemical, or improper storage or handling.

*Produce* means to manufacture, process, formulate, blend, extract, generate, emit, or repackage.

*Product identifier* means the name or number used for a hazardous chemical on a label or in the SDS. It provides a unique means by which the user can identify the chemical. The product identifier used shall permit cross-references to be made among the list of hazardous chemicals required in the written hazard communication program, the label and the SDS.

*Pyrophoric gas* means a chemical in a gaseous state that will ignite spontaneously in air at a temperature of 130 degrees F (54.4 degrees C) or below.

*Responsible party* means someone who can provide additional information on the hazardous chemical and appropriate emergency procedures, if necessary.

*Safety data sheet (SDS)* means written or printed material concerning a hazardous chemical that is prepared in accordance with paragraph (g) of this section.

*Signal word* means a word used to indicate the relative level of severity of hazard and alert the reader to a potential hazard on the label. The signal words used in this section are "danger" and "warning." "Danger" is used for the more severe hazards, while "warning" is used for the less severe.

*Simple asphyxiant* means a substance or mixture that displaces oxygen in the ambient atmosphere, and can thus cause oxygen deprivation in those who are exposed, leading to unconsciousness and death.

*Specific chemical identity* means the chemical name, Chemical Abstracts Service (CAS) Registry Number, or any other information that reveals the precise chemical designation of the substance.

*Substance* means chemical elements and their compounds in the natural state or obtained by any production process, including any additive necessary to preserve the stability of the product and any impurities deriving from the process used, but excluding any solvent which may be separated without affecting the stability of the substance or changing its composition.

*Trade secret* means any confidential formula, pattern, process, device, information or compilation of information that is used in an employer's business, and that gives the employer an opportunity to obtain an advantage over competitors who do not know or use it. Appendix E to 1910.1200 Definition of Trade Secret, sets out the criteria to be used in evaluating trade secrets.

*Use* means to package, handle, react, emit, extract, generate as a byproduct, or transfer.

*Work area* means a room or defined space in a workplace where hazardous chemicals are produced or used, and where employees are present.

*Workplace* means an establishment, job site, or project, at one geographical location containing one or more work areas.

1910.1200(d)

*Hazard classification.*

1910.1200(d)(1)

Chemical manufacturers and importers shall evaluate chemicals produced in their workplaces or imported by them to classify the chemicals in accordance with this section. For each chemical, the chemical manufacturer or importer shall determine the hazard classes, and, where appropriate, the category of each class that apply to the chemical being classified. Employers are not required to classify chemicals unless they choose not to rely on the classification performed by the chemical manufacturer or importer for the chemical to satisfy this requirement.

1910.1200(d)(2)

Chemical manufacturers, importers or employers classifying chemicals shall identify and consider the full range of available scientific literature and other evidence concerning the potential hazards. There is no requirement to test the chemical to determine how to classify its hazards. Appendix A to § 1910.1200 shall be consulted for classification of health hazards, and Appendix B to § 1910.1200 shall be consulted for the classification of physical hazards.

1910.1200(d)(3)

*Mixtures.*

1910.1200(d)(3)(i)

Chemical manufacturers, importers, or employers evaluating chemicals shall follow the procedures described in Appendices A and B to Sec. 1910.1200 to classify the hazards of the chemicals, including determinations regarding when mixtures of the classified chemicals are covered by this section.

1910.1200(d)(3)(ii)

When classifying mixtures they produce or import, chemical manufacturers and importers of mixtures may rely on the information provided on the current safety data sheets of the individual ingredients, except where the chemical manufacturer or importer knows, or in the

exercise of reasonable diligence should know, that the safety data sheet misstates or omits information required by this section.

1910.1200(e)

*Written hazard communication program.*

1910.1200(e)(1)

Employers shall develop, implement, and maintain at each workplace, a written hazard communication program which at least describes how the criteria specified in paragraphs (f), (g), and (h) of this section for labels and other forms of warning, safety data sheets, and employee information and training will be met, and which also includes the following:

1910.1200(e)(1)(i)

A list of the hazardous chemicals known to be present using a product identifier that is referenced on the appropriate safety data sheet (the list may be compiled for the workplace as a whole or for individual work areas); and,

1910.1200(e)(1)(ii)

The methods the employer will use to inform employees of the hazards of non-routine tasks (for example, the cleaning of reactor vessels), and the hazards associated with chemicals contained in unlabeled pipes in their work areas.

1910.1200(e)(2)

*Multi-employer workplaces.* Employers who produce, use, or store hazardous chemicals at a workplace in such a way that the employees of other employer(s) may be exposed (for example, employees of a construction contractor working on-site) shall additionally ensure that the hazard communication programs developed and implemented under this paragraph (e) include the following:

1910.1200(e)(2)(i)

The methods the employer will use to provide the other employer(s) on-site access to safety data sheets for each hazardous chemical the other employer(s)' employees may be exposed to while working;

1910.1200(e)(2)(ii)

The methods the employer will use to inform the other employer(s) of any precautionary measures that need to be taken to protect employees during the workplace's normal operating conditions and in foreseeable emergencies; and,

1910.1200(e)(2)(iii)

The methods the employer will use to inform the other employer(s) of the labeling system used in the workplace.

1910.1200(e)(3)

The employer may rely on an existing hazard communication program to comply with these requirements, provided that it meets the criteria established in this paragraph (e).

1910.1200(e)(4)

The employer shall make the written hazard communication program available, upon request, to employees, their designated representatives, the Assistant Secretary and the Director, in accordance with the requirements of 29 CFR 1910.1020 (e).

1910.1200(e)(5)

Where employees must travel between workplaces during a workshift, i.e., their work is carried out at more than one geographical location, the written hazard communication program may be kept at the primary workplace facility.

1910.1200(f)

*Labels and other forms of warning—*

1910.1200(f)(1)

*Labels on shipped containers.* The chemical manufacturer, importer, or distributor shall ensure that each container of hazardous chemicals leaving the workplace is labeled, tagged, or marked. Hazards not otherwise classified do not have to be addressed on the container. Where the chemical manufacturer or importer is required to label, tag or mark the following information shall be provided:

1910.1200(f)(1)(i)

Product identifier;

1910.1200(f)(1)(ii)

Signal word;

1910.1200(f)(1)(iii)

Hazard statement(s);

1910.1200(f)(1)(iv)

Pictogram(s);

1910.1200(f)(1)(v)

Precautionary statement(s); and,

1910.1200(f)(1)(vi)

Name, address, and telephone number of the chemical manufacturer, importer, or other responsible party.

1910.1200(f)(2)

The chemical manufacturer, importer, or distributor shall ensure that the information provided under paragraphs (f)(1)(i) through (v) of this section is in accordance with Appendix C to § 1910.1200, for each hazard class and associated hazard category for the hazardous chemical, prominently displayed, and in English (other languages may also be included if appropriate).

1910.1200(f)(3)

The chemical manufacturer, importer, or distributor shall ensure that the information provided under paragraphs (f)(1)(ii) through (iv) of this section is located together on the label, tag, or mark.

1910.1200(f)(4)

*Solid materials.*

1910.1200(f)(4)(i)

For solid metal (such as a steel beam or a metal casting), solid wood, or plastic items that are not exempted as articles due to their downstream use, or shipments of whole grain, the required label may be transmitted to the customer at the time of the initial shipment, and need not be included with subsequent shipments to the same employer unless the information on the label changes;

1910.1200(f)(4)(ii)

The label may be transmitted with the initial shipment itself, or with the safety data sheet that is to be provided prior to or at the time of the first shipment; and,

1910.1200(f)(4)(iii)

This exception to requiring labels on every container of hazardous chemicals is only for the solid material itself, and does not apply to hazardous chemicals used in conjunction with, or known to be present with, the material and to which employees handling the items in transit may be exposed (for example, cutting fluids or pesticides in grains).

1910.1200(f)(5)

Chemical manufacturers, importers, or distributors shall ensure that each container of hazardous chemicals leaving the workplace is labeled, tagged, or marked in accordance with this section in a manner which does not conflict with the requirements of the Hazardous Materials Transportation

Act (49 U.S.C. 1801 *et seq.*) and regulations issued under that Act by the Department of Transportation.

1910.1200(f)(6)

Workplace labeling. Except as provided in paragraphs (f)(7) and (f)(8) of this section, the employer shall ensure that each container of hazardous chemicals in the workplace is labeled, tagged or marked with either:

1910.1200(f)(6)(i)

The information specified under paragraphs (f)(1)(i) through (v) of this section for labels on shipped containers; or,

1910.1200(f)(6)(ii)

Product identifier and words, pictures, symbols, or combination thereof, which provide at least general information regarding the hazards of the chemicals, and which, in conjunction with the other information immediately available to employees under the hazard communication program, will provide employees with the specific information regarding the physical and health hazards of the hazardous chemical.

1910.1200(f)(7)

The employer may use signs, placards, process sheets, batch tickets, operating procedures, or other such written materials in lieu of affixing labels to individual stationary process containers, as long as the alternative method identifies the containers to which it is applicable and conveys the information required by paragraph (f)(6) of this section to be on a label. The employer shall ensure the written materials are readily accessible to the employees in their work area throughout each work shift.

1910.1200(f)(8)

The employer is not required to label portable containers into which hazardous chemicals are transferred from labeled containers, and which are intended only for the immediate use of the employee who performs the transfer. For purposes of this section, drugs which are dispensed by a pharmacy to a health care provider for direct administration to a patient are exempted from labeling.

1910.1200(f)(9)

The employer shall not remove or deface existing labels on incoming containers of hazardous chemicals, unless the container is immediately marked with the required information.

1910.1200(f)(10)

The employer shall ensure that workplace labels or other forms of warning are legible, in English, and prominently displayed on the container, or readily available in the work area throughout each work shift. Employers having employees who speak other languages may add the information in their language to the material presented, as long as the information is presented in English as well.

1910.1200(f)(11)

Chemical manufacturers, importers, distributors, or employers who become newly aware of any significant information regarding the hazards of a chemical shall revise the labels for the chemical within six months of becoming aware of the new information, and shall ensure that labels on containers of hazardous chemicals shipped after that time contain the new information. If the chemical is not currently produced or imported, the chemical manufacturer, importer, distributor, or employer shall add the information to the label before the chemical is shipped or introduced into the workplace again.

1910.1200(g)

*Safety data sheets.*

1910.1200(g)(1)

Chemical manufacturers and importers shall obtain or develop a safety data sheet for each hazardous chemical they produce or import. Employers shall have a safety data sheet in the workplace for each hazardous chemical which they use.

1910.1200(g)(2)

The chemical manufacturer or importer preparing the safety data sheet shall ensure that it is in English (although the employer may maintain copies in other languages as well), and includes at least the following section numbers and headings, and associated information under each heading, in the order listed (See Appendix D to § 1910.1200—Safety Data Sheets, for the specific content of each section of the safety data sheet):

1910.1200(g)(2)(i)

Section 1, Identification;

1910.1200(g)(2)(ii)

Section 2, Hazard(s) identification;

1910.1200(g)(2)(iii)

Section 3, Composition/information on ingredients;

1910.1200(g)(2)(iv)

Section 4, First-aid measures;

1910.1200(g)(2)(v)

Section 5, Fire-fighting measures;

1910.1200(g)(2)(vi)

Section 6, Accidental release measures;

1910.1200(g)(2)(vii)

Section 7, Handling and storage;

1910.1200(g)(2)(viii)

Section 8, Exposure controls/personal protection;

1910.1200(g)(2)(ix)

Section 9, Physical and chemical properties;

1910.1200(g)(2)(x)

Section 10, Stability and reactivity;

1910.1200(g)(2)(xi)

Section 11, Toxicological information;

1910.1200(g)(2)(xii)

Section 12, Ecological information;

1910.1200(g)(2)(xiii)

Section 13, Disposal considerations;

1910.1200(g)(2)(xiv)

Section 14, Transport information;

1910.1200(g)(2)(xv)

Section 15, Regulatory information; and

1910.1200(g)(2)(xvi)

Section 16, Other information, including date of preparation or last revision.

Note 1 to paragraph (g)(2): To be consistent with the GHS, an SDS must also include the headings in paragraphs (g)(2)(xii) through (g)(2)(xv) in order.

Note 2 to paragraph (g)(2): OSHA will not be enforcing information requirements in sections 12 through 15, as these areas are not under its jurisdiction.

1910.1200(g)(3)

If no relevant information is found for any sub-heading within a section on the safety data sheet, the chemical manufacturer, importer or employer preparing the safety data sheet shall mark it to indicate that no applicable information was found.

1910.1200(g)(4)

Where complex mixtures have similar hazards and contents (i.e. the chemical ingredients are essentially the same, but the specific composition varies from mixture to mixture), the chemical manufacturer, importer or employer may prepare one safety data sheet to apply to all of these similar mixtures.

1910.1200(g)(5)

The chemical manufacturer, importer or employer preparing the safety data sheet shall ensure that the information provided accurately reflects the scientific evidence used in making the hazard classification. If the chemical manufacturer, importer or employer preparing the safety data sheet becomes newly aware of any significant information regarding the hazards of a chemical, or ways to protect against the hazards, this new information shall be added to the safety data sheet within three months. If the chemical is not currently being produced or imported, the chemical manufacturer or importer shall add the information to the safety data sheet before the chemical is introduced into the workplace again.

1910.1200(g)(6)(i)

Chemical manufacturers or importers shall ensure that distributors and employers are provided an appropriate safety data sheet with their initial shipment, and with the first shipment after a safety data sheet is updated;

1910.1200(g)(6)(ii)

The chemical manufacturer or importer shall either provide safety data sheets with the shipped containers or send them to the distributor or employer prior to or at the time of the shipment;

1910.1200(g)(6)(iii)

If the safety data sheet is not provided with a shipment that has been labeled as a hazardous chemical, the distributor or employer shall obtain one from the chemical manufacturer or importer as soon as possible; and,

1910.1200(g)(6)(iv)

The chemical manufacturer or importer shall also provide distributors or employers with a safety data sheet upon request.

1910.1200(g)(7)(i)

Distributors shall ensure that safety data sheets, and updated information, are provided to other distributors and employers with their initial shipment and with the first shipment after a safety data sheet is updated;

1910.1200(g)(7)(ii)

The distributor shall either provide safety data sheets with the shipped containers, or send them to the other distributor or employer prior to or at the time of the shipment;

1910.1200(g)(7)(iii)

Retail distributors selling hazardous chemicals to employers having a commercial account shall provide a safety data sheet to such employers upon request, and shall post a sign or otherwise inform them that a safety data sheet is available;

1910.1200(g)(7)(iv)

Wholesale distributors selling hazardous chemicals to employers over-the-counter may also provide safety data sheets upon the request of the employer at the time of the over-the-counter purchase, and shall post a sign or otherwise inform such employers that a safety data sheet is available;

1910.1200(g)(7)(v)

If an employer without a commercial account purchases a hazardous chemical from a retail distributor not required to have safety data sheets on file (i.e., the retail distributor does not have commercial accounts and does not use the materials), the retail distributor shall provide the employer, upon request, with the name, address, and telephone number of the chemical manufacturer, importer, or distributor from which a safety data sheet can be obtained;

1910.1200(g)(7)(vi)

Wholesale distributors shall also provide safety data sheets to employers or other distributors upon request; and,

1910.1200(g)(7)(vii)

Chemical manufacturers, importers, and distributors need not provide safety data sheets to retail distributors that have informed them that the retail distributor does not sell the product to commercial accounts or open the sealed container to use it in their own workplaces.

1910.1200(g)(8)

The employer shall maintain in the workplace copies of the required safety data sheets for each hazardous chemical, and shall ensure that they are readily accessible during each work shift to employees when they are in their work area(s). (Electronic access and other alternatives to maintaining paper copies of the safety data sheets are permitted as long as no barriers to immediate employee access in each workplace are created by such options.)

1910.1200(g)(9)

Where employees must travel between workplaces during a workshift, *i.e.*, their work is carried out at more than one geographical location, the material safety data sheets may be kept at the primary workplace facility. In this situation, the employer shall ensure that employees can immediately obtain the required information in an emergency.

1910.1200(g)(10)

Safety data sheets may be kept in any form, including operating procedures, and may be designed to cover groups of hazardous chemicals in a work area where it may be more appropriate to address the hazards of a process rather than individual hazardous chemicals. However, the employer shall ensure that in all cases the required information is provided for each hazardous chemical, and is readily accessible during each work shift to employees when they are in their work area(s).

1910.1200(g)(11)

Safety data sheets shall also be made readily available, upon request, to designated representatives, the Assistant Secretary, and the Director, in accordance with the requirements of § 1910.1020(e).

1910.1200(h)

*Employee information and training.*

1910.1200(h)(1)

Employers shall provide employees with effective information and training on hazardous chemicals in their work area at the time of their initial assignment, and whenever a new chemical hazard the employees have not previously been trained about is introduced into their work area. Information and training may be designed to cover categories of hazards (e.g., flammability, carcinogenicity) or specific chemicals. Chemical-specific information must always be available through labels and safety data sheets.

1910.1200(h)(2)

*Information.* Employees shall be informed of:

1910.1200(h)(2)(i)

The requirements of this section;

1910.1200(h)(2)(ii)

Any operations in their work area where hazardous chemicals are present; and,

1910.1200(h)(2)(iii)

The location and availability of the written hazard communication program, including the required list(s) of hazardous chemicals, and safety data sheets required by this section.

1910.1200(h)(3)

*Training.* Employee training shall include at least:

1910.1200(h)(3)(i)

Methods and observations that may be used to detect the presence or release of a hazardous chemical in the work area (such as monitoring conducted by the employer, continuous monitoring devices, visual appearance or odor of hazardous chemicals when being released, etc.);

1910.1200(h)(3)(ii)

The physical, health, simple asphyxiation, combustible dust, and pyrophoric gas hazards, as well as hazards not otherwise classified, of the chemicals in the work area;

1910.1200(h)(3)(iii)

The measures employees can take to protect themselves from these hazards, including specific procedures the employer has implemented to protect employees from exposure to hazardous chemicals, such as appropriate work practices, emergency procedures, and personal protective equipment to be used; and,

1910.1200(h)(3)(iv)

The details of the hazard communication program developed by the employer, including an explanation of the labels received on shipped containers and the workplace labeling system used by their employer; the safety data sheet, including the order of information and how employees can obtain and use the appropriate hazard information.

1910.1200(i)

*Trade secrets.*

1910.1200(i)(1)

The chemical manufacturer, importer, or employer may withhold the specific chemical identity, including the chemical name, other specific identification of a hazardous chemical, or the exact percentage (concentration) of the substance in a mixture, from the safety data sheet, provided that:

1910.1200(i)(1)(i)

The claim that the information withheld is a trade secret can be supported;

1910.1200(i)(1)(ii)

Information contained in the safety data sheet concerning the properties and effects of the hazardous chemical is disclosed;

1910.1200(i)(1)(iii)

The safety data sheet indicates that the specific chemical identity and/or percentage of composition is being withheld as a trade secret; and,

1910.1200(i)(1)(iv)

The specific chemical identity and percentage is made available to health professionals, employees, and designated representatives in accordance with the applicable provisions of this paragraph (i).

1910.1200(i)(2)

Where a treating physician or nurse determines that a medical emergency exists and the specific chemical identity and/or specific percentage of composition of a hazardous chemical is necessary for emergency or first-aid treatment, the chemical manufacturer, importer, or employer shall immediately disclose the specific chemical identity or percentage composition of a trade secret chemical to that treating physician or nurse, regardless of the existence of a written statement of

need or a confidentiality agreement. The chemical manufacturer, importer, or employer may require a written statement of need and confidentiality agreement, in accordance with the provisions of paragraphs (i)(3) and (4) of this section, as soon as circumstances permit.

1910.1200(i)(3)

In non-emergency situations, a chemical manufacturer, importer, or employer shall, upon request, disclose a specific chemical identity or percentage composition, otherwise permitted to be withheld under paragraph (i)(1) of this section, to a health professional (i.e. physician, industrial hygienist, toxicologist, epidemiologist, or occupational health nurse) providing medical or other occupational health services to exposed employee(s), and to employees or designated representatives, if:

1910.1200(i)(3)(i)

The request is in writing;

1910.1200(i)(3)(ii)

The request describes with reasonable detail one or more of the following occupational health needs for the information:

1910.1200(i)(3)(ii)(A)

To assess the hazards of the chemicals to which employees will be exposed;

1910.1200(i)(3)(ii)(B)

To conduct or assess sampling of the workplace atmosphere to determine employee exposure levels;

1910.1200(i)(3)(ii)(C)

To conduct pre-assignment or periodic medical surveillance of exposed employees;

1910.1200(i)(3)(ii)(D)

To provide medical treatment to exposed employees;

1910.1200(i)(3)(ii)(E)

To select or assess appropriate personal protective equipment for exposed employees;

1910.1200(i)(3)(ii)(F)

To design or assess engineering controls or other protective measures for exposed employees; and,

1910.1200(i)(3)(ii)(G)

To conduct studies to determine the health effects of exposure.

1910.1200(i)(3)(iii)

The request explains in detail why the disclosure of the specific chemical identity or percentage composition is essential and that, in lieu thereof, the disclosure of the following information to the health professional, employee, or designated representative, would not satisfy the purposes described in paragraph (i)(3)(ii) of this section:

1910.1200(i)(3)(iii)(A)

The properties and effects of the chemical;

1910.1200(i)(3)(iii)(B)

Measures for controlling workers' exposure to the chemical;

1910.1200(i)(3)(iii)(C)

Methods of monitoring and analyzing worker exposure to the chemical; and,

1910.1200(i)(3)(iii)(D)

Methods of diagnosing and treating harmful exposures to the chemical;

1910.1200(i)(3)(iv)

The request includes a description of the procedures to be used to maintain the confidentiality of the disclosed information; and,

1910.1200(i)(3)(v)

The health professional, and the employer or contractor of the services of the health professional (i.e. downstream employer, labor organization, or individual employee), employee, or designated representative, agree in a written confidentiality agreement that the health professional, employee, or designated representative, will not use the trade secret information for any purpose other than the health need(s) asserted and agree not to release the information under any circumstances other than to OSHA, as provided in paragraph (i)(6) of this section, except as authorized by the terms of the agreement or by the chemical manufacturer, importer, or employer.

1910.1200(i)(4)

The confidentiality agreement authorized by paragraph (i)(3)(iv) of this section:

1910.1200(i)(4)(i)

May restrict the use of the information to the health purposes indicated in the written statement of need;

1910.1200(i)(4)(ii)

May provide for appropriate legal remedies in the event of a breach of the agreement, including stipulation of a reasonable pre-estimate of likely damages; and,

1910.1200(i)(4)(iii)

May not include requirements for the posting of a penalty bond.

1910.1200(i)(5)

Nothing in this standard is meant to preclude the parties from pursuing non-contractual remedies to the extent permitted by law.

1910.1200(i)(6)

If the health professional, employee, or designated representative receiving the trade secret information decides that there is a need to disclose it to OSHA, the chemical manufacturer, importer, or employer who provided the information shall be informed by the health professional, employee, or designated representative prior to, or at the same time as, such disclosure.

1910.1200(i)(7)

If the chemical manufacturer, importer, or employer denies a written request for disclosure of a specific chemical identity or percentage composition, the denial must:

1910.1200(i)(7)(i)

Be provided to the health professional, employee, or designated representative, within thirty days of the request;

1910.1200(i)(7)(ii)

Be in writing;

1910.1200(i)(7)(iii)

Include evidence to support the claim that the specific chemical identity or percent of composition is a trade secret;

1910.1200(i)(7)(iv)

State the specific reasons why the request is being denied; and,

1910.1200(i)(7)(v)

Explain in detail how alternative information may satisfy the specific medical or occupational health need without revealing the trade secret.

1910.1200(i)(8)

The health professional, employee, or designated representative whose request for information is denied under paragraph (i)(3) of this section may refer the request and the written denial of the request to OSHA for consideration.

1910.1200(i)(9)

When a health professional, employee, or designated representative refers the denial to OSHA under paragraph (i)(8) of this section, OSHA shall consider the evidence to determine if:

1910.1200(i)(9)(i)

The chemical manufacturer, importer, or employer has supported the claim that the specific chemical identity or percentage composition is a trade secret;

1910.1200(i)(9)(ii)

The health professional, employee, or designated representative has supported the claim that there is a medical or occupational health need for the information; and,

1910.1200(i)(9)(iii)

The health professional, employee or designated representative has demonstrated adequate means to protect the confidentiality.

1910.1200(i)(10)(i)

If OSHA determines that the specific chemical identity or percentage composition requested under paragraph (i)(3) of this section is not a "bona fide" trade secret, or that it is a trade secret, but the requesting health professional, employee, or designated representative has a legitimate medical or occupational health need for the information, has executed a written confidentiality agreement, and has shown adequate means to protect the confidentiality of the information, the chemical manufacturer, importer, or employer will be subject to citation by OSHA.

1910.1200(i)(10)(ii)

If a chemical manufacturer, importer, or employer demonstrates to OSHA that the execution of a confidentiality agreement would not provide sufficient protection against the potential harm from the unauthorized disclosure of a trade secret, the Assistant Secretary may issue such orders or impose such additional limitations or conditions upon the disclosure of the requested chemical information as may be appropriate to assure that the occupational health services are provided without an undue risk of harm to the chemical manufacturer, importer, or employer.

1910.1200(i)(11)

If a citation for a failure to release trade secret information is contested by the chemical manufacturer, importer, or employer, the matter will be adjudicated before the Occupational Safety and Health Review Commission in accordance with the Act's enforcement scheme and the applicable Commission rules of procedure. In accordance with the Commission rules, when a chemical manufacturer, importer, or employer continues to withhold the information during the contest, the Administrative Law Judge may review the citation and supporting documentation "in camera" or issue appropriate orders to protect the confidentiality of such matters.

1910.1200(i)(12)

Notwithstanding the existence of a trade secret claim, a chemical manufacturer, importer, or employer shall, upon request, disclose to the Assistant Secretary any information which this section requires the chemical manufacturer, importer, or employer to make available. Where there is a trade secret claim, such claim shall be made no later than at the time the information is provided to the Assistant Secretary so that suitable determinations of trade secret status can be made and the necessary protections can be implemented.

1910.1200(i)(13)

Nothing in this paragraph shall be construed as requiring the disclosure under any circumstances of process information which is a trade secret.

1910.1200(j)

*Effective dates.*

1910.1200(j)(1)

Employers shall train employees regarding the new label elements and safety data sheets format by December 1, 2013.

1910.1200(j)(2)

Chemical manufacturers, importers, distributors, and employers shall be in compliance with all modified provisions of this section no later than June 1, 2015, except:

1910.1200(j)(2)(i)

After December 1, 2015, the distributor shall not ship containers labeled by the chemical manufacturer or importer unless the label has been modified to comply with paragraph (f)(1) of this section.

1910.1200(j)(2)(ii)

All employers shall, as necessary, update any alternative workplace labeling used under paragraph (f)(6) of this section, update the hazard communication program required by paragraph (h)(1), and provide any additional employee training in accordance with paragraph (h)(3) for newly identified physical or health hazards no later than June 1, 2016.

1910.1200(j)(3)

Chemical manufacturers, importers, distributors, and employers may comply with either § 1910.1200 revised as of October 1, 2011, or the current version of this standard, or both during the transition period.

[59 FR 6170, Feb. 9, 1994, as amended at 59 FR 17479, Apr. 13, 1994; 59 FR 65948, Dec. 22, 1994; 61 FR 9245, Mar. 7, 1996; 77 FR 17785, Mar. 26, 2012; 78 FR 9313, Feb. 8, 2013]

<https://www.osha.gov/laws-regs/regulations/standardnumber/1910/1910.1200>

# Hazard Communication Guidelines for Compliance

---



U.S. Department of Labor  
Occupational Safety and Health Administration

OSHA 3111  
2000 (Reprinted)

This informational booklet is intended to provide a generic, non-exhaustive overview of a particular standards-related topic. This publication does not itself alter or determine compliance responsibilities, which are set forth in OSHA standards themselves and the *Occupational Safety and Health Act*. Moreover, because interpretations and enforcement policy may change over time, for additional guidance on OSHA compliance requirements, the reader should consult current and administrative interpretations and decisions by the Occupational Safety and Health Review Commission and the Courts.

Material contained in this publication is in the public domain and may be reproduced, fully or partially, without permission of the Federal Government. Source credit is requested but not required.

---

This information will be made available to sensory impaired individuals upon request.

Voice phone: (202) 693-1999

# Hazard Communication Guidelines for Compliance

---



U.S. Department of Labor  
Alexis M. Herman, Secretary

Occupational Safety and Health Administration  
Charles N. Jeffress, Assistant Secretary

OSHA 3111  
2000 (Reprinted)

---

<b>Introduction .....</b>	<b>1</b>
<b>Becoming Familiar with the Rule .....</b>	<b>2</b>
<b>Identifying Responsible Staff.....</b>	<b>5</b>
<b>Identifying Hazardous Chemicals in the Workplace.....</b>	<b>6</b>
<b>Preparing and Implementing a Hazard Communication Program .....</b>	<b>8</b>
Labels and Other Forms of Warning .....	9
Material Safety Data Sheets .....	10
Employee Information and Training .....	12
<b>Other Requirements .....</b>	<b>15</b>
<b>Checklist for Compliance .....</b>	<b>16</b>
<b>Further Assistance .....</b>	<b>17</b>
<b>Other Sources of OSHA Assistance .....</b>	<b>18</b>
Safety and Health Program Management.....	18
State Programs.....	18
Consultation Services .....	19
Voluntary Protection Programs.....	19
Training and Education .....	19
<b>OSHA Related Publications .....</b>	<b>21</b>
<b>States with Approved Plans .....</b>	<b>22</b>
<b>OSHA Consultation Project Directory .....</b>	<b>25</b>
<b>OSHA Area Offices.....</b>	<b>27</b>

---

OSHA's Hazard Communication Standard (HCS) is based on a simple concept—that employees have both a need and a right to know the hazards and identities of the chemicals they are exposed to when working. They also need to know what protective measures are available to prevent adverse effects from occurring. OSHA designed the HCS to provide employees with the information they need to know.

Knowledge acquired under the HCS will help employers provide safer workplaces for their employees. When employees have information about the chemicals being used, they can take steps to reduce exposures, substitute less hazardous materials, and establish proper work practices. These efforts will help prevent the occurrence of work-related illnesses and injuries caused by chemicals.

The HCS addresses the issues of evaluating and communicating chemical hazard information to workers. Evaluation of chemical hazards involves a number of technical concepts, and is a process that requires the professional judgment of experienced experts. That's why the HCS is designed so that employers who simply use chemicals—rather than produce or import them—are not required to evaluate the hazards of those chemicals. Hazard determination is the responsibility of the manufacturers and importers of the chemicals, who then must provide the hazard information to employers that purchase their products

Employers that do not produce or import chemicals need only focus on those parts of the rule that deal with establishing a workplace program and communicating information to their workers. This publication is a general guide for such employers to help them determine what the HCS requires. It does not supplant or substitute for the regulatory provisions, but rather provides a simplified outline of the steps an average employer would follow to meet those requirements.

OSHA has provided a simple summary of the HCS in a pamphlet entitled *Chemical Hazard Communication (OSHA 3084)*. Some employers prefer to familiarize themselves with the rule's requirements by reading this pamphlet. A single, free copy may be obtained from your local OSHA Area Office, or by contacting the OSHA Publications Office at (202) 693-1888.

The standard itself is long and some parts are technical, but the basic concepts are simple. In fact, the requirements reflect what many employers have been doing for years. You may find that you already largely comply with many of the provisions and will simply have to modify your existing programs somewhat. If you are operating in an OSHA-approved State Plan State, you must comply with the State's requirements, which may be different than those of the Federal rule. Many of the State Plan States had hazard communication or "right-to-know" laws prior to promulgation of the federal rule. Employers in State Plan States should contact their State OSHA Offices for more information regarding applicable requirements. (See the list of contacts in "States with Approved Plans" at the back of this booklet.)

The HCS requires information to be prepared and transmitted regarding all hazardous chemicals. The HCS covers both physical hazards (such as flammability) and health hazards (such as irritation, lung damage, and cancer.) Most chemicals used in the workplace have some hazard potential, and thus will be covered by the rule.

One difference between this rule and many others adopted by OSHA is that this one is performance-oriented. That means you have the flexibility to adapt the rule to the needs of your workplace, rather than having to follow specific rigid requirements. It also means that you have to exercise more judgment to implement an appropriate and effective program.

The standard's design is simple. Chemical manufacturers and importers must evaluate the hazards of the chemicals they produce or import. Using that information, they must then prepare labels for containers and more detailed technical bulletins called material safety data sheets (MSDSs).

Chemical manufacturers, importers, and distributors of hazardous chemicals are all required to provide the appropriate labels and material safety data sheets to the employers to whom they ship the

---

chemicals. The information must be provided automatically. Every container of hazardous chemicals you receive must be labeled, tagged, or marked with the required information. Your suppliers also must send you a properly completed MSDS at the time of the first shipment of the chemicals, and with the next shipment after the MSDS is updated with new and significant information about the hazards.

You can rely on the information received from your suppliers. You have no independent duty to analyze the chemical or evaluate the hazards of it.

Employers that “use” hazardous chemicals must have a program to ensure the information is provided to exposed employees. “Use” means to package, handle, react, or transfer. This is an intentionally broad scope, and includes any situation where a chemical is present in such a way that employees may be exposed under normal conditions of use or in a foreseeable emergency.

The requirements of the rule that deal specifically with the hazard communication program are found in the standard in paragraphs (e), written hazard communication programs; (f), labels and other forms of warning; (g), material safety data sheets; and (h), employee information and training. The requirements of these paragraphs should be the focus of your attention. Concentrate on becoming familiar with them, using paragraphs (b), scope and application, and (c), definitions, as references when needed to help explain the provisions.

There are two types of work operations where coverage of the rule is limited. These are laboratories and operations where chemicals are only handled in sealed containers (e.g., a warehouse). The limited provisions for these workplaces can be found in paragraph (b), scope and application. Basically, employers having these types of work operations need only keep labels on containers as they are received, maintain material safety data sheets that are received and give employees access to them, and provide information and training for employees. Employers do not have to have written hazard communication programs and lists of chemicals for these types of operations.

The limited coverage of laboratories and sealed container operations addresses the obligation of an employer to the workers in the

---

operations involved, and does not affect the employer's duties as a distributor of chemicals. For example, a distributor may have warehouse operations where employees would be protected under the limited sealed container provisions. In this situation, requirements for obtaining and maintaining MSDSs are limited to providing access to those received with containers while the substance is in the workplace, and requesting MSDSs when employees request access for those not received with the containers. However, as a distributor of hazardous chemicals, that employer will still have responsibility for providing MSDSs to downstream customers at the time of the first shipment and when the MSDS is updated. Therefore, although they may not be required for the employees in the work operation, the distributor may, nevertheless, have to have MSDSs to satisfy other requirements of the rule.

---

Hazard communication will be a continuing program in your facility. Compliance with HCS is not a “one shot deal.” In order to have a successful program, you must assign responsibility for both the initial and ongoing activities that have to be undertaken to comply with the rule. In some cases, these activities may be part of current job assignments. For example, Site Supervisors are frequently responsible for on-the-job training sessions. Early identification of the responsible employees and their involvement in developing your action plan will result in a more effective program design. Involving affected employees also will enhance the evaluation of the effectiveness of your program.

For any safety and health program, success depends on commitment at every level of the organization. This is particularly true for hazard communication, where success requires a change in behavior. This will occur only if employers understand the program and are committed to its success, and if the people presenting the information motivate employees.

The standard requires a list of hazardous chemicals in the workplace as part of the written hazard communication program. The list will eventually serve as an inventory of everything for which you must maintain an MSDS. At this point, however, preparing the list will help you complete the rest of the program since it will give you some idea of the scope of the program required for compliance in your facility.

The best way to prepare a comprehensive list is to survey the workplace. Purchasing records also may help, and certainly employers should establish procedures to ensure that in the future purchasing procedures result in MSDSs being received before using a material in the workplace.

The broadest possible perspective should be taken when doing the survey. Sometimes people think of “chemicals” as being only liquids in containers. The HCS covers chemicals in all physical forms—liquids, solids, gases, vapors, fumes, and mists—whether they are “contained” or not. The hazardous nature of the chemical and the potential for exposure are the factors that determine whether a chemical is covered. If it’s not hazardous, it’s not covered. If there is no potential for exposure, (e.g., the chemical is inextricably bound and cannot be released), the rule does not cover the chemical.

Look around. Identify the chemicals in containers, including pipes, but also think about chemicals generated in the work operations. For example, welding fumes, dusts, and exhaust fumes are all sources of chemical exposures. Read labels provided by the suppliers on hazard information. Make a list of all chemicals in the workplace that are potentially hazardous. For your own information and planning, you also may want to note on the list the location(s) of the products within the workplace, and an indication of the hazards as found on the label. This will help you as you prepare the rest of your program.

Paragraph (b), scope and application, includes exemptions for various chemicals or workplace situations. After compiling the complete list of chemicals, you should review paragraph (b) to determine if any of the items can be eliminated from the list because they are exempted materials. For example, food, drugs, and cosmetics brought into the workplace for employee consumption are exempt; rubbing alcohol in the first aid kit would not be covered.

---

Once you have compiled as complete a list as possible of the potentially hazardous chemicals in the workplace, the next step is to determine if you have received material safety data sheets for all of them. Check your files against the inventory you have just compiled. If any are missing, contact your supplier and request one. It is a good idea to document these requests, either by copy of a letter or a note regarding telephone conversations. If you have MSDSs for chemicals that are not on your list, figure out why. Maybe you don't use the chemical anymore. Or maybe you missed it in your survey. Some suppliers do provide MSDSs for products that are not hazardous. These do not have to be maintained by you. If you have questions regarding the hazard status of a chemical, contact the manufacturer, distributor, or importer.

You should not allow employees to use any chemicals for which you have not received an MSDS. The MSDS provides information you need to ensure you have implemented proper protective measures for exposure.

The HCS requires all workplaces where employees are exposed to hazardous chemicals to have a written plan that describes how that facility will implement the standard. Preparation of the plan is not just a paper exercise—all of the elements must be implemented in the workplace to comply with the rule. See paragraph (e) of the standard for the specific requirements regarding written hazard communication programs. The only work operations that do not have to comply with the written plan requirements are laboratories and work operations where employees only handle chemicals in sealed containers. See paragraph (b), scope and application, for the specific requirements for these two types of workplaces.

The plan does not have to be lengthy or complicated. It is intended to be a blueprint for implementing your program—an assurance that all aspects of the requirements have been addressed.

Many trade associations and other professional groups have provided sample programs and other assistance materials to affect employers. These have been very helpful to many employers since they tend to be tailored to the particular industry involved. You may wish to investigate whether your industry trade groups have developed such materials.

Although such general guidance may be helpful, you must remember that the written program has to reflect what you are doing in your workplace. Therefore, if you use a generic program, you must adapt it to address the facility it covers.

For example, the written plan must list the chemicals present at the site and indicate where written materials will be made available to employees. It also may indicate who is responsible for the various aspects of the program in your facility.

If OSHA inspects your workplace for compliance with the HCS, the OSHA compliance officer will ask to see your written plan at the outset of the inspection. In general, the following items will be considered in evaluating your program.

The written program must describe how the requirements for labels and other forms of warning, materials safety data sheets, and employee information and training, are going to be met in your facility. The following discussion provides the type of information compliance officers will be looking for to decide whether you have properly addressed these elements of the hazard communication program.

---

---

## Labels and Other Forms of Warning

In-plant containers of hazardous chemicals must be labeled, tagged, or marked with the identity of the material and appropriate hazard warnings. Chemical manufacturers, importers, and distributors must ensure that every container of hazardous chemicals they ship is appropriately labeled with such information and with the name and address of the producer or other responsible party. Employers purchasing chemicals can rely on the labels provided by their suppliers. If the material is subsequently transferred by the employer from a labeled container to another container, the employer will have to label that container, unless it is subject to the portable container exemption. See paragraph (f) for specific labeling requirements.

The primary information to be obtained from an OSHA-required label is the identity for the material and appropriate hazard warnings. The identity is any term which appears on the label, the MSDS, and the list of chemicals, and thus links these three sources of information. The identity used by the supplier may be a common or trade name (“Black Magic Formula”), or a chemical name (1, 1, 1 - trichloroethane). The hazard warning is a brief statement of the hazardous effects of the chemical (“flammable,” “causes lung damage”). Labels frequently contain other information, such as precautionary measures (“do not use near open flame”) but this information is provided voluntarily and is not required by the rule. Labels must be legible and prominently displayed. There are no specific requirements for size or color or any specified test.

With these requirements in mind, the compliance officer will be looking for the following types of information to ensure that labeling is properly implemented in your facility:

- Designation of person(s) responsible for ensuring labeling of in-plant containers;
- Designation of person(s) responsible for ensuring labeling of any shipped container;
- Description of labeling system(s) used;
- Description of written alternatives to labeling of in-plant containers (if used); and,
- Procedures to review and update label information when necessary.

---

Employers that are purchasing and using hazardous chemicals—rather than producing or distributing them—will primarily be concerned with ensuring that every purchased container is labeled. If materials are transferred into other containers, the employer must ensure that these are labeled as well, unless they fall under the portable container exemption (paragraph f(7)). In terms of labeling systems, you can choose to use the labels provided by your suppliers on the containers. These will generally be verbal text labels, and do not usually include numerical rating systems or symbols that require special training. The most important thing to remember is that this is a continuing duty—all in-plant containers of hazardous chemicals must always be labeled. Therefore, it is important to designate someone to be responsible for ensuring that the labels are maintained as required on the containers in your facility and that newly purchased materials are checked for labels prior to use.

### **Material Safety Data Sheets**

Chemical manufacturers and importers are required to obtain or develop a material safety data sheet for each hazardous chemical they produce or import. Distributors are responsible for ensuring that their customers are provided a copy of these MSDSs. Employers must have an MSDS for each hazardous chemical which they use. Employers may rely on the information received from their suppliers. The specific requirements for material safety data sheets are in paragraph (g) of the standard.

There is no specific format for the MSDS under the rule, although there are specific information requirements. OSHA has developed a nonmandatory format, OSHA Form 174, which may be used by chemical manufacturers and importers to comply with the rule. The MSDS must be in English. You are entitled to receive from your supplier a data sheet which includes all of the information required under the rule. If you do not receive one automatically, you should request one. If you receive one that is obviously inadequate, with, for example, blank spaces that are not completed, you should request an appropriately completed one. If your request for a data sheet or for a corrected data sheet does not produce the information needed, you should contact your local OSHA Area Office for assistance in obtaining the MSDS.

---

Under the rule, the role of MSDSs is to provide detailed information on each hazardous chemical, including its potential hazardous effects, its physical and chemical characteristics, and recommendations for appropriate protective measures. This information should be useful to you as the employer responsible for designing protective programs, as well as to the workers. If you are not familiar with material safety data sheets and with chemical terminology, you may need to learn to use them yourself. A glossary of MSDS terms may be helpful in this regard. Generally speaking, most employers using hazardous chemicals will primarily be concerned with MSDS information regarding hazardous effects and recommended protective measures. Focus on the sections of the MSDS that are applicable to your situation.

MSDSs must be readily accessible to employees when they are in their work areas during their workshifts. This may be accomplished in many different ways. You must decide what is appropriate for your particular workplace. Some employers keep the MSDSs in a binder in a central location (e.g., in the pickup truck on a construction site.) Others, particularly in workplaces with large numbers of chemicals, computerize the information and provide access through terminals. As long as employees can get the information when they need it, any approach may be used. The employees must have access to the MSDSs themselves—simply having a system where the information can be read to them over the phone is permitted only under the mobile worksite provision, paragraph (g)(9), when employees must travel between workplaces during the shift. In this situation, they have access to the MSDSs prior to leaving the primary worksite, and when they return, so the telephone system is simply an emergency arrangement.

In order to ensure that you have a current MSDS for each chemical in the plant as required, and that you provide employee access, the compliance officers will be looking for the following types of information in your written program:

- Designation of person(s) responsible for obtaining and maintaining the MSDSs;
- How such sheets are to be maintained in the workplace (e.g., in notebooks in the work area(s) or in a computer with terminal access), and how employees can obtain access to them when they are in their work area during the workshift;

- 
- Procedures to follow when the MSDS is not received at the time of the first shipment;
  - For producers, procedures to update the MSDS when new and significant health information is found; and,
  - Description of alternatives to actual data sheets in the workplace, if used.

For employers using hazardous chemicals, the most important aspect of the written program in terms of MSDSs is to ensure that someone is responsible for obtaining and maintaining the MSDSs for every hazardous chemical in the workplace. The list of hazardous chemicals required to be maintained as part of the written program will serve as an inventory. As new chemicals are purchased, the list should be updated. Many companies have found it convenient to include on their purchase order the name and address of the person designated in their company to receive MSDSs.

### **Employee Information and Training**

Each employee who may be “exposed” to hazardous chemicals when working must be provided information and be trained prior to initial assignment to work with a hazardous chemical, and whenever the hazard changes. “Exposure” or “exposed” under the rule means that an employee is subjected to a hazardous chemical in the course of employment through any route of entry (inhalation, ingestion, skin contact, or absorption) and includes potential (e.g., accidental or possible) exposure. See paragraph (h) of the standard for specific requirements. Information and training may be done either by individual chemical, or by categories of hazards (such as flammability or carcinogenicity). If there are only a few chemicals in the workplace, then you may want to discuss each one individually. Where there are a large number of chemicals, or the chemicals change frequently, you will probably want to train generally based on the hazard categories (e.g., flammable liquids, corrosive materials, carcinogens). Employees will have access to the substance-specific information on the labels and MSDSs. Employers must ensure, however, that employees are made aware of which hazard category a chemical falls within.

Information and training are a critical part of the hazard communication program. Workers obtain information regarding hazards and

---

protective measures through written labels and material safety data sheets. It is through effective information and training, however, that workers will learn to read and understand such information, determine how to acquire and use it in their own workplace, and understand the risks of exposure to the chemical in their workplaces as well as the ways to protect themselves. A properly conducted training program will ensure comprehension and understanding. It is not sufficient to either just read material to the workers or simply hand them material to read. You want to create a climate where workers feel free to ask questions. This will help you to ensure that the information is understood. You must always remember that the underlying purpose of the HCS is to reduce the incidence of chemical source illnesses and injuries. This will be accomplished by modifying behavior through the provision of hazard information and information about protective measures. If your program works, you and your workers will better understand the chemical hazards within the workplace. The procedures you establish, regarding, for example, purchasing, storage, and handling of these chemicals will improve, and thereby reduce the risks posed to employees exposed to the chemical hazards involved. Furthermore, your workers' comprehension also will be increased, and proper work practices will be followed in your workplace.

If you are going to do the training yourself, you will have to understand the material and be prepared to motivate the workers to learn. This is not always an easy task, but the benefits are worth the effort. More information regarding appropriate training can be found in *Training Requirements in OSHA Standards and Training Guidelines (OSHA 2254)*, which contains voluntary training guidelines prepared by OSHA's Training Institute. A copy of this document is available from the Superintendent of Documents, Government Printing Office, P.O. Box 371954, Pittsburgh, PA 15250-7954; (202) 512-1800.

When reviewing your written program regarding information and training, consider the following items:

- Designation of person(s) responsible for conducting training;
- Format of the program used (audiovisuals, class room instruction);
- Elements of the training programs (should be consistent with the elements in paragraph (h) of the HCS); and,

- Procedure to train new employees at the time of their initial assignment to work with a hazardous chemical, and to train employees when introducing a new hazard into the workplace.

The written program should provide enough details about the employer's plans in this area to assess whether or not a good faith effort is being made to train employees. OSHA does not expect that every workers will be able to recite all the information about each chemical in the workplace. In general, the most important aspects of training under the HCS are to ensure that employees are aware that they are exposed to hazardous chemicals, that they know how to read and use labels and material safety data sheets, and that, as a consequence of learning this information, they are following the appropriate protective measures established by the employer. OSHA compliance officers will be talking to employees to determine if they have received training, if they know they are exposed to hazardous chemicals, and if they know where to obtain substance specific information on labels and MSDSs.

The rule does not require employers to maintain records of employee training, but many employers choose to do so. This may help you monitor your own program to ensure that you have trained all employees appropriately. If you already have a training program, you may simply have to supplement it with whatever additional information is required under the HCS. For example, construction employers that are already in compliance with the construction training standard (29 CFR 1926.21 ) will have little extra training to do.

An employer can provide employees information and training through whatever means found appropriate and protective. Although there would always have to be some training on site (such as informing employees of the location and availability of the written program and MSDSs), employee training may be satisfied in part by general training about the requirements of the HCS which is provided by, for example, trade associations, unions, colleges, and professional schools. In addition, previous training, education, and experience of a worker may relieve the employer of some of the burdens of information and training that worker. Regardless of the method relied upon, however, the employer is always ultimately responsible for ensuring that employees are adequately trained. If the compliance

---

officer finds that the training is deficient, the employer will be cited for the deficiency regardless of who actually provided the training on behalf of the employer.

In addition to these specific items, compliance officers also will be asking the following questions in assessing the adequacy of the program:

- Does a list of the hazardous chemicals exist in each work area or at a central location?
- Are methods the employer will use to inform employees of the hazards of non-routine tasks outlined?
- Are employees informed of the hazards associated with chemicals contained in unlabeled pipes in their work areas?
- On multi-employer worksites, has the employer provided other employers with information about labeling systems and precautionary measures where the other employers have employees exposed to the initial employer's chemicals?
- Is the written program made available to employees and their designated representatives?

If your program adequately addresses the means of communicating information to employees in your workplace and provides answers to the basic questions outlined above, it will comply with the rule.

The following checklist will help to ensure you comply with the rule:

- Obtained a copy of the rule.
- Read and understood the requirements.
- Assigned responsibility for tasks.
- Prepared an inventory of chemicals.
- Ensured containers are labeled.
- Obtained MSDS for each chemical.
- Prepared written program.
- Made MSDSs available to workers.
- Conducted training of workers.
- Established procedures to maintain current program.
- Established procedures to evaluate effectiveness.

---

If you have a question regarding compliance with HCS, you should contact your local OSHA Area Office for assistance. In addition, each OSHA Regional Office has a Hazard Communication Coordinator who can answer your questions. Free consultation services also are available to assist employers, and information regarding these services can be obtained through the OSHA Area and Regional Offices as well (see lists at the end of this booklet).

---

## **Safety and Health Program Management**

Effective management of worker safety and health protection is a decisive factor in reducing the extent and severity of work-related injuries and illnesses and their related costs. To assist employers and employees in developing effective safety and health programs, OSHA published recommended *Safety and Health Program Management Guidelines* (*Federal Register* 54(18):3908-3916, January 26, 1989). These voluntary guidelines apply to all places of employment covered by OSHA.

The guidelines identify four general elements that are critical to the development of a successful safety and health management program:

- management commitment and employee involvement;
- worksite analysis;
- hazard prevention and control; and
- safety and health training.

The guidelines recommend specific actions under each of these general elements to achieve an effective safety and health program. A single, free copy of the guidelines can be obtained from the U.S. Department of Labor, OSHA Publications, P.O. Box 37535, Washington, DC 20013-7535, by sending a self-addressed mailing label with your request.

---

## **State Programs**

*The Occupational Safety and Health Act of 1970* encourages states to develop and operate their own job safety and health plans. States with plans approved under section 18(b) of the OSH Act must adopt standards and enforce requirements that are at least as effective as federal requirements. There are currently 25 state plan states: 23 of these states administer plans covering both private and public (state and local public government) employees; the other two states, Connecticut and New York, cover public employees only. Plan states must adopt standards comparable to federal requirements within six months of a federal standard's promulgation. Until such time as a state standard is promulgated, Federal OSHA provides interim enforcement assistance, as appropriate, in these states. A listing of approved state plans appear at the end of this publication.

---

## Consultation Services

Consultation assistance is available on request to employers who want help in establishing and maintaining a safe and healthful workplace. Largely funded by OSHA, the service is provided at no cost to the employer. Primarily developed for smaller employers with more hazardous operations, the consultation service is delivered by state government agencies or universities employing professional safety consultants and health consultants. Comprehensive assistance includes an appraisal of all work practices and environmental hazards of the workplace and all aspects of the employer's present job safety and health program.

The program is separate from OSHA's inspection efforts. No penalties are proposed or citations issued for any safety or health problems identified by the consultant. The service is confidential.

For more information concerning consultation assistance, see the list of consultation projects at the end of this publication.

---

## Voluntary Protection Programs (VPP)

Voluntary Protection Programs (VPP) and onsite consultation services, when coupled with an effective enforcement program, expand worker protection to help meet the goals of the OSH Act. The three VPPs—Star, Merit, and Demonstration—are designed to recognize outstanding achievement by companies that have successfully incorporated comprehensive safety and health programs into their total management system. They motivate others to achieve excellent safety and health results in the same outstanding way as they establish a cooperative relationship among employers, employees, and OSHA.

For additional information on VPP and how to apply, contact your nearest OSHA area or regional office listed at the end of this publication.

## Training and Education

OSHA Area Offices offer a variety of information services, such as publications, audiovisual aids, technical advice, and speakers for special engagements. The OSHA Training Institute in Des Plaines,

---

IL, provides basic and advanced courses in safety and health for federal and state compliance officers, state consultants, federal agency personnel, and private sector employers, employees, and their representatives.

OSHA also provides funds to nonprofit organizations, through grants to conduct workplace training and education in subjects where OSHA believes there is a lack of workplace training. Grants are awarded annually and grant recipients are expected to contribute 20 percent of the total grant cost.

For more information on grants, training, and education, contact the OSHA Training Institute, Office of Training and Education, 1555 Times Drive, Des Plaines, IL 60018, (847) 297-4810; (847) 297-4874 fax.

---

### **Electronic Information**

Internet-OSHA standards, interpretations, directives, and additional information are now on the World Wide Web at <http://www.osha.gov/> and <http://www.osha-slc.gov/>.

CD-ROM—A wide variety of OSHA materials, including standards, interpretations, directives, and more can be purchased on CD-ROM from the U.S. Government Printing Office. To order, write to the Superintendent of Documents, P.O. Box 371954, Pittsburgh, PA 15250-7954, or phone (202) 512-1800. Specify OSHA Regulations, Documents, and Technical Information on CD-ROM (ORDT), GPO Order NO. S/N 729-013-00000-5. The price is \$48 per year (\$57.50 foreign); \$17 per single copy (\$21.25 foreign).

---

### **Emergencies**

For life-threatening situations, call (800) 321-OSHA. Complaints will go immediately to the nearest OSHA area or state office for help.

For further information on any OSHA program, contact your nearest OSHA area or regional office listed at the end of this publication.

---

Single free copies of the following publications can be obtained from the OSHA Publications Office, P.O. Box 37535, Washington, DC 20013-7535. Send a self-addressed mailing label with your request.

**All About OSHA – OSHA 2056**

**Chemical Hazard Communication – OSHA 3084**

**Consultation Services for the Employer – OSHA 3074**

**Employee Workplace Rights – OSHA 3021**

**Employer Rights and Responsibilities Following an OSHA Inspection – OSHA 3000**

**How to Prepare for Workplace Emergencies – OSHA 3088**

**OSHA Inspections – OSHA 2098**

**Personal Protective Equipment – OSHA 3077**

**Respiratory Protection – OSHA 3079**

The following publications may be ordered at cost, from the Superintendent of Documents, U.S. Government Printing Office, Washington DC 20402, (202) 512-1800. Include GPO Order No. and make checks payable to Superintendent of Documents.

**Code of Federal Regulations – Title 29, Part 1926**

***Construction (OSHA)* (\$30)**

Order No. S/N 869-038-00107-1

***OSHA Safety and Health Standards (29 CFR 1910.1000 to End)***

(\$28) Order No. S/N 869-038-00105-5.

***Handbook for Small Business* – OSHA 2209 (\$7.50)**

Order No. 029-016-00176-0.

**Commissioner**

Alaska Department of Labor  
1111 West 8th Street  
Room 304  
Juneau, AK 99801-1149  
(907) 465-2700

**Director**

Industrial Commission of Arizona  
800 W. Washington  
Phoenix, AZ 85007-2922  
(602) 542-5795

**Director**

California Department  
of Industrial Relations  
455 Golden Gate Avenue -  
10th Floor  
San Francisco, CA 94102  
(415) 703-5050

**Commissioner**

Connecticut Department of Labor  
200 Folly Brook Boulevard  
Wethersfield, CT 06109  
(860) 566-5123

**Director**

Hawaii Department of Labor  
and Industrial Relations  
830 Punchbowl Street  
Honolulu, HI 96813  
(808) 586-8844

**Commissioner**

Indiana Department of Labor  
State Office Building  
402 West Washington Street  
Room W195  
Indianapolis, IN 46204-2751  
(317) 232-2378

**Commissioner**

Iowa Division of Labor Services  
1000 E. Grand Avenue  
Des Moines, IA 50319-0209  
(515) 281-3447

**Secretary**

Kentucky Labor Cabinet  
1047 U.S. Highway, 127 South,  
Suite 4  
Frankfort, KY 40601  
(502) 564-3070

**Commissioner**

Maryland Division of Labor  
and Industry  
Department of Labor, Licensing,  
and Regulation  
1100 N. Eutaw Street,  
Room 613  
Baltimore, MD 21201-2206  
(410) 767-2215

**Director**

Michigan Department  
of Consumer and Industry  
Services  
P.O. Box 30643  
Lansing, MI 48909-8143  
(517) 322-1814

**Commissioner**

Minnesota Department of Labor  
and Industry  
443 Lafayette Road  
St. Paul, MN 55155-4307  
(651) 296-2342

**Administrator**

Nevada Division of Industrial  
Relations  
400 West King Street  
Carson City, NV 89710  
(775) 687-3032

**Secretary**

New Mexico Environment  
Department  
1190 St. Francis Drive  
P.O. Box 26110  
Santa Fe, NM 87502  
(505) 827-2850

**Commissioner**

New York Department of Labor  
W. Averell Harriman State Office  
Building - 12, Room 500  
Albany, NY 12240  
(518) 457-2741

**Commissioner**

North Carolina Department  
of Labor  
4 West Edenton Street  
Raleigh, NC 27601-1092  
(919) 807-7166

**Administrator**

Department of Consumer  
and Business Services  
Occupational Safety and Health  
Division (OR-OSHA)  
350 Winter Street, NE,  
Room 430  
Salem, OR 97310-0220  
(503) 378-3272

**Secretary**

Puerto Rico Department  
of Labor and Human Resources  
Prudencio Rivera Martinez  
Building  
505 Munoz Rivera Avenue  
Hato Rey, PR 00918  
(787) 754-2119

**Director**

South Carolina Department  
of Labor, Licensing, and  
Regulation  
Koger Office Park,  
Kingstree Building  
110 Centerview Drive  
P.O. Box 11329  
Columbia, SC 29210  
(803) 896-4300

**Commissioner**

Tennessee Department of Labor  
Attention: Robert Taylor  
710 James Robertson Parkway  
Nashville, TN 37243-0659  
(615) 741-2582

**Commissioner**

Labor Commission of Utah  
160 East 300 South, 3rd Floor  
P.O. Box 146650  
Salt Lake City, UT 84114-6650  
(801) 530-6898

**Commissioner**

Vermont Department  
of Labor and Industry  
National Life Building -  
Drawer 20  
National Life Drive  
Montpelier, VT 05620-3401  
(802) 828-5098

**Commissioner**

Virginia Department of Labor  
and Industry  
Powers-Taylor Building  
13 South 13th Street  
Richmond, VA 23219  
(804) 786-2377

**Commissioner**

Virgin Islands Department  
of Labor  
2203 Church Street  
Christiansted  
St. Croix, VI 00820-4660  
(340) 773-1994

**Director**

Washington Department  
of Labor and Industries  
P.O. Box 44001  
Olympia, WA 98504-4001  
(360) 902-4200

**Administrator**

Worker's Safety and  
Compensation Division (WSC)  
Wyoming Department  
of Employment  
Herschler Building,  
2nd Floor East  
122 West 25th Street  
Cheyenne, WY 82002  
(307) 777-7786

---

<b>State</b>	<b>Telephone</b>
Alabama.....	(205) 348-3033
Alaska.....	(907) 269-4957
Arizona.....	(602) 542-1695
Arkansas.....	(501) 682-4522
California.....	(415) 703-5270
Colorado.....	(970) 491-6151
Connecticut.....	(860) 566-4550
Delaware.....	(302) 761-8219
District of Columbia.....	(202) 576-6339
Florida.....	(850) 922-8955
Georgia.....	(404) 894-2643
Guam.....	011(671) 475-0136
Hawaii.....	(808) 586-9100
Idaho.....	(208) 426-3283
Illinois.....	(312) 814-2337
Indiana.....	(317) 232-2688
Iowa.....	(515) 281-7162
Kansas.....	(785) 296-7476
Kentucky.....	(502) 564-6895
Louisiana.....	(504) 342-9601
Maine.....	(207) 624-6460
Maryland.....	(410) 880-4970
Massachusetts.....	(617) 727-3982
Michigan.....	(517) 322-6823(H)
.....	(517) 322-1809(S)
Minnesota.....	(612) 297-2393
Mississippi.....	(601) 987-3981
Missouri.....	(573) 751-3403
Montana.....	(406) 444-6418
Nebraska.....	(402) 471-4717
Nevada.....	(702) 486-9140
New Hampshire.....	(603) 271-2024
New Jersey.....	(609) 292-3923
New Mexico.....	(505) 827-4230
New York.....	(518) 457-2238
North Carolina.....	(919) 807-2905
North Dakota.....	(701) 328-5188
Ohio.....	(614) 644-2246
Oklahoma.....	(405) 528-1500

---

---

Oregon .....	(503) 378-3272
Pennsylvania.....	(724) 357-2396
Puerto Rico .....	(787) 754-2171
Rhode Island.....	(401) 222-2438
South Carolina.....	(803) 734-9614
South Dakota .....	(605) 688-4101
Tennessee.....	(615) 741-7036
Texas .....	(512) 804-4640
Utah .....	(801) 530-6901
Vermont .....	(802) 828-2765
Virginia .....	(804) 786-6359
Virgin Islands.....	(340) 772-1315
Washington.....	(360) 902-5638
West Virginia .....	(304) 558-7890
Wisconsin .....	(608) 266-8579(H)
.....	(262) 523-3040(S)
Wyoming .....	(307) 777-7786

(H) - Health

(S) - Safety

---

<b>Area</b>	<b>Telephone</b>
Albany, NY .....	(518) 464-4338
Albuquerque, NM .....	(505) 248-5302
Allentown, PA .....	(610) 776-0592
Anchorage, AK .....	(907) 271-5152
Appleton, WI .....	(920) 734-4521
Austin, TX .....	(512) 916-5783
Avenel, NJ .....	(908) 750-3270
Bangor, ME .....	(207) 941-8179
Baton Rouge, LA .....	(225) 389-0474
Bayside, NY .....	(718) 279-9060
Bellevue, WA .....	(206) 553-7520
Billings, MT .....	(406) 247-7494
Birmingham, AL .....	(205) 731-1534
Bismarck, ND .....	(701) 250-4521
Boise, ID .....	(208) 321-2960
Bowmansville, NY .....	(716) 684-3891
Braintree, MA .....	(617) 565-6924
Bridgeport, CT .....	(203) 579-5516
Calumet City, IL .....	(708) 891-3800
Carson City, NV .....	(702) 885-6963
Charleston, WV .....	(304) 347-5937
Cincinnati, OH .....	(513) 841-4132
Cleveland, OH .....	(216) 522-3818
Columbia, SC .....	(803) 765-5904
Columbus, OH .....	(614) 469-5582
Concord, NH .....	(603) 225-1629
Corpus Christi, TX .....	(512) 888-3420
Dallas, TX .....	(214) 320-2400
Denver, CO .....	(303) 844-5285
Des Plaines, IL .....	(847) 803-4800
Des Moines, IA .....	(515) 284-4794
Eau Claire, WI .....	(715) 832-9019
El Paso, TX .....	(915) 534-6251
Englewood, CO .....	(303) 843-4500
Erie, PA .....	(814) 833-5758
Fairview Heights, IL .....	(618) 632-8612
Fort Lauderdale, FL .....	(954) 424-0242
Fort Worth, TX .....	(817) 428-2470
Frankfort, KY .....	(502) 227-7024
Guaynabo, PR .....	(787) 277-1560
Harrisburg, PA .....	(717) 782-3902
Hartford, CT .....	(860) 240-3152
Hasbrouck Heights, NJ .....	(201) 288-1700
Honolulu, HI .....	(808) 541-2685
Houston, TX .....	(281) 286-0583

---

---

Houston, TX	(281) 591-2438
Indianapolis, IN	(317) 226-7290
Jackson, MS	(601) 965-4606
Jacksonville, FL	(904) 232-2895
Kansas City, MO	(816) 483-9531
Linthicum, MD	(410) 865-2055
Little Rock, AR	(501) 324-6291
Lubbock, TX	(806) 472-7681
Madison, WI	(608) 441-5388
Marlton, NJ	(609) 757-5181
Methuen, MA	(617) 565-8110
Milwaukee, WI	(414) 297-3315
Minneapolis, MN	(612) 664-5460
Mobile, AL	(334) 441-6131
Nashville, TN	(615) 781-5423
New York, NY	(212) 466-2482
Norfolk, VA	(757) 441-3820
North Aurora, IL	(630) 896-8700
Oklahoma City, OK	(405) 231-5351
Omaha, NE	(402) 221-3182
Parsippany, NJ	(201) 263-1003
Peoria, IL	(309) 671-7033
Philadelphia, PA	(215) 597-4955
Phoenix, AZ	(602) 640-2007
Pittsburgh, PA	(412) 395-4903
Portland, ME	(207) 780-3178
Portland, OR	(503) 326-2251
Providence, RI	(401) 528-4663
Raleigh, NC	(919) 856-4770
Sacramento, CA	(916) 566-7470
Salt Lake City, UT	(801) 487-0680
San Diego, CA	(619) 557-2909
Savannah, GA	(912) 652-4393
Smyrna, GA	(770) 984-8700
Springfield, MA	(413) 785-0123
St. Louis, MO	(314) 425-4249
Syracuse, NY	(315) 451-0808
Tampa, FL	(813) 626-1177
Tarrytown, NY	(914) 524-7510
Toledo, OH	(419) 259-7542
Tucker, GA	(770) 493-6644
Westbury, NY	(516) 334-3344
Wichita, KS	(316) 269-6644
Wilkes-Barre, PA	(717) 826-6538
Wilmington, DE	(302) 573-6115

## OSHA Regional Offices

### **Region I**

(CT,\* MA, ME, NH, RI, VT\*)  
JFK Federal Building  
Room E-340  
Boston, MA 02203  
Telephone: (617) 565-9860

### **Region II**

(NJ, NY,\* PR,\* VI\*)  
201 Varick Street  
Room 670  
New York, NY 10014  
Telephone: (212) 337-2378

### **Region III**

(DC, DE, MD,\* PA, VA,\* WV)  
The Curtis Center - Suite 740 West  
170 S. Independence Mall West  
Philadelphia, PA 19106-3309  
Telephone: (215) 861-4900

### **Region IV**

(AL, FL, GA, KY,\* MS, NC,\*  
SC,\* TN\*)  
Atlanta Federal Center  
61 Forsyth Street, SW, Room 6T50  
Atlanta, GA 30303  
Telephone: (404) 562-2300

### **Region V**

(IL, IN,\* MI,\* MN,\* OH, WI)  
230 South Dearborn Street  
Room 3244  
Chicago, IL 60604  
Telephone: (312) 353-2220

### **Region VI**

(AR, LA, MN,\* OK, TX)  
525 Griffin Street  
Room 602  
Dallas, TX 75202  
Telephone: (214) 767-4731

### **Region VII**

(IA,\* KS, MO, NE)  
City Center Square  
1100 Main Street, Suite 800  
Kansas City, MO 64105  
Telephone: (816) 426-5861

### **Region VIII**

(CO, MT, ND, SD, UT,\* WY\*)  
1999 Broadway  
Suite 1690  
Denver, CO 80802-5716  
Telephone: (303) 844-1600

### **Region IX**

(American Samoa, AZ,\* CA,\*  
Guam, HI,\* NV,\* Trust  
Territories of the Pacific)  
71 Stevenson Street  
4th Floor  
San Francisco, CA 94105  
Telephone: (415) 975-4310

### **Region X**

(AK,\* ID, OR,\* WA\*)  
1111 Third Avenue  
Suite 715  
Seattle, WA 98101-3212  
Telephone: (206) 553-5930

\*These states and territories operate their own OSHA-approved job safety and health programs (Connecticut and New York plans cover public employees only). States with approved programs must have a standard that is identical to, or at least as effective as, the federal standard.

# **SECTION 9**

## **Lead Paint Safety: A Field Guide for Painting, Home Maintenance, and Renovation Work**



# Lead Paint Safety

**A Field Guide for  
Painting, Home  
Maintenance, and  
Renovation Work**

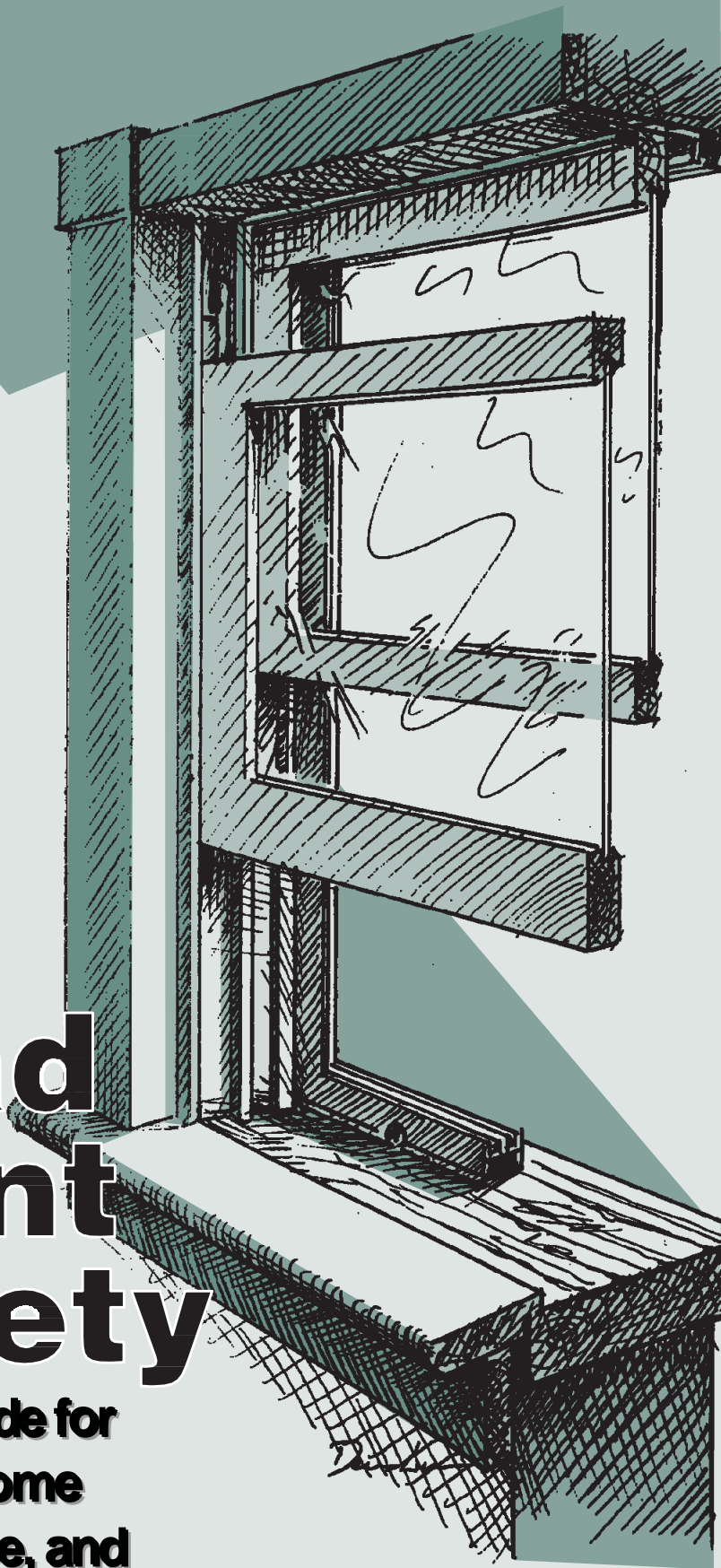

U.S. Department of Housing  
and Urban Development  
Office of Healthy Homes and  
Lead Hazard Control

## Foreword

Every child should have a lead-safe home. That's why HUD is working to create lead-safe affordable housing through outreach and public education, a lead hazard control grant program, worker training, and the enforcement of regulations.

This guide is one part of HUD's comprehensive approach to lead safety in the home. If you perform routine maintenance on homes or apartments built before 1978, this guide will help you plan and carry out your work safely. Step-by-step instructions and illustrations explain and show what you need to do to protect yourself and your clients if you are working in older housing that could contain lead paint. This Field Guide is a valuable tool that thousands of workers and contractors across the country are using as part of a national effort to eliminate childhood lead poisoning.

Thank you for working lead-safe. It's helping protect America's children.

A handwritten signature in black ink, appearing to read "Mel Martinez". The signature is fluid and cursive, written in a professional style.

Mel Martinez, Secretary  
U.S. Department of Housing and Urban Development

## Acknowledgements

The U.S. Department of Housing and Urban Development (HUD) developed this guide with the assistance and input of the Centers for Disease Control and Prevention (CDC), the U.S. Environmental Protection Agency (EPA), and the Occupational Safety and Health Administration (OSHA). HUD would like to thank the staff of these agencies for their participation in developing this Field Guide. HUD would also like to thank all of the renovation, painting, maintenance, and lead professionals who provided useful feedback. Vicki Ainslie, Dana Bres, Robert Brown, Kevin Cleary, Alan Isaac, David Levitt, Linda Lewis, Dennis Livingston, Eric Oetjen, Roy Reveilles, Ron Rupp, Joe Shimer, Aaron Sussell, Peter Tieman, David Thompson, Richard Tobin, Ellen Tohn, Veda Watts, and Mike Wilson served on the Technical Panel for this project. A special thanks goes to these individuals for their contributions.

This Guide was developed by the U.S. Department of Housing and Urban Development's Office of Healthy Homes and Lead Hazard Control through a contract with ICF Incorporated. Dennis Livingston created the illustrations and provided technical content for this Field Guide.

# WHY SHOULD I FOLLOW THIS GUIDE?

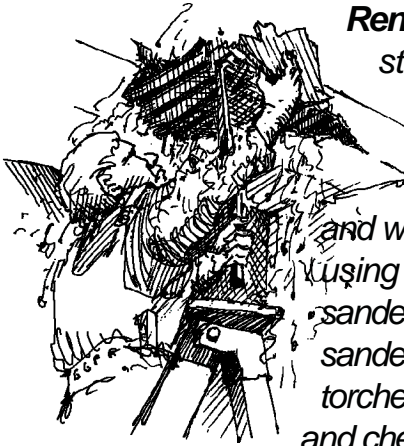

**Renovation of a two-story, 19th century house included removing paint from floors and woodwork using power sanders, hand sanders, scrapers, torches, heat guns, and chemical paint strip-**

**pers.** Ceilings were also repaired, and wallpaper and paint were removed from several walls. The family that owned the home temporarily moved out of the house. They returned when the work was only partly completed. There was dust throughout the house.

The family discovered that something was wrong when one of the family's dogs began to have seizures. A veterinarian found that the dog had been lead poisoned. The mother and children had their blood tested, and found that all of them had very high levels of lead in their blood. All three were admitted to the hospital for severe lead poisoning.

**A painter was hired to repaint the exterior of an old**

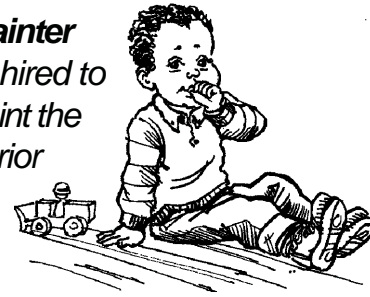

**Vermont home occupied by a couple expecting the birth of their first child. The painter used a power grinder to remove the old paint from the exterior siding. While the painter worked, the window to the baby's nursery was left open, and the entire room, including the crib, became covered with dust.**

Fortunately, the couple noticed the dust, and understood the potential risk. They called in another painter who was qualified to control lead hazards. He cleaned up the paint dust and the newborn baby moved into a clean, safe home.

## Most Old Homes Contain Lead-Based Paint

- Most homes built before 1978 contain some lead-based paint. Lead-based paint is more common and was used more extensively in homes built before 1950.

Probability of a House Containing Lead

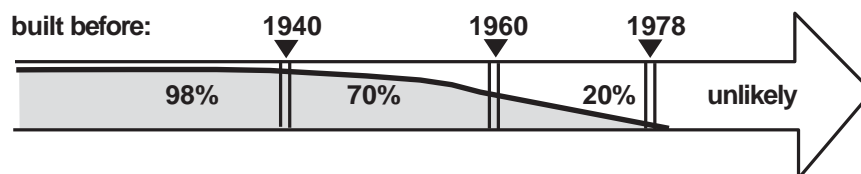

- Homes built before 1950 also used paint that had a higher concentration of lead.

# WHY FOLLOW THIS GUIDE?

## Poor Maintenance Endangers Children

- In poorly maintained houses, lead-based paint, which may be several layers down, flakes and peels off. Paint failure is usually caused by moisture problems. Sometimes rubbing or impact causes paint failure. Doing work improperly can also cause a lot of dust.
- Lead-based paint chips and dust then mix with house dust and build up in window troughs and on floors.
- Children are endangered when lead in paint chips, dust, and soil gets on their hands and toys which they may put in their mouths.
- Lead can make children very sick and cause permanent brain and nerve damage. It can also result in learning difficulties and behavior problems. This damage is irreversible. It is a tragedy we can prevent.
- If paint is kept intact and surfaces are kept clean, children can live safely in a home painted with lead-based paint.
- Uncontrolled or uncontained dust and debris from repainting and/or renovation that disturbs lead-based paint in a well-maintained home can also expose children to unsafe levels of lead.

## Changing Common Work Practices Can Protect Workers and Children

- Lead-based paint can also pose a threat to workers by causing damage to their brains, and nervous and reproductive systems.
- With small changes in work practices, workers can protect themselves and their customers from lead exposure.
- These changes include:
  - Keeping dust to a minimum.
  - Confining dust and paint chips to the work area.
  - Cleaning up during and after work. Special cleanup procedures must always be used.
  - Taking dust wipe samples to make sure cleaning removed lead-contaminated dust. (Dust wipe sampling is described in Section 5D, p. 71.)

## Who Should Use This Guide?

- Building maintenance workers and their supervisors
- Painters
- Repair, renovation, and remodeling contractors
- Property managers and owners
- Homeowners
- Local housing agency staff and public health staff

## When Should I Follow This Guide?

- To fix a specific problem.
- During routine maintenance or apartment turnover.
- In homes where there may be a young child or a pregnant woman.
- During work supported by Federal funds that must be performed using safe work practices under Federal regulations.

# H O W T O U S E T H I S G U I D E

**This guide is divided into 5 sections.**

To locate a section, bend the bottom of these pages. Look for the section you want by lining up the boxes at the bottom of each page.

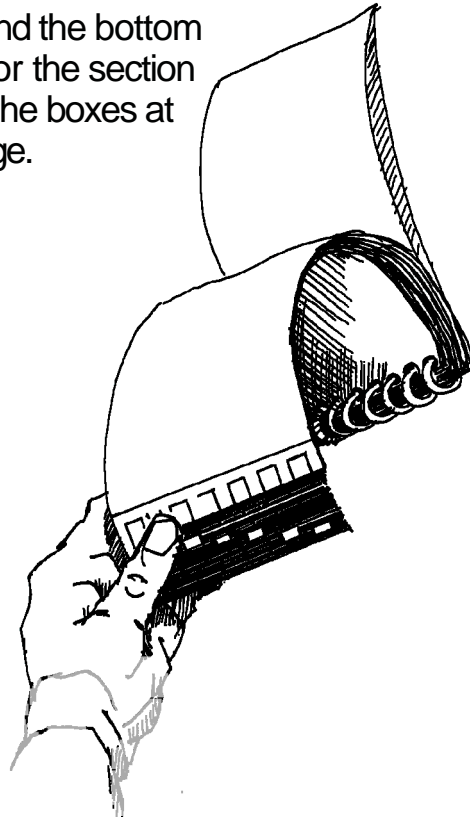

**The Basics**

**Before You Start Work**

**Doing the Work**

**At the End of the Job**

**Resources**  
(Includes Glossary)

1

2

3

4

5

3

# C O N T E N T S O F T H I S G U I D E

<b>1. The Basics.....</b>	<b>5</b>
Remember these Principles .....	5
Routine Work Practices.....	6
Correcting the Cause of the Problem .....	7
Restricted Practices .....	9
Key Stages of a Job.....	11
<b>2. Before You Start Work.....</b>	<b>13</b>
Set Up the Work Area - Interior .....	13
Set Up the Work Area - Exterior .....	15
Worker Protection.....	17
<b>3. Doing the Work.....</b>	<b>19</b>
Painting Jobs	
<input type="checkbox"/> Interior Surface Prep .....	19
<input type="checkbox"/> Exterior Surface Prep .....	22
<input type="checkbox"/> Paint Removal .....	23
Home Maintenance and Renovation Jobs	
<input type="checkbox"/> Walls/Ceilings.....	25
<input type="checkbox"/> Windows .....	29
<input type="checkbox"/> Doors .....	37
<input type="checkbox"/> Stairs/Floors .....	41
<input type="checkbox"/> Trim.....	43
<input type="checkbox"/> High Dust Jobs.....	45
<b>4. At The End of the Job .....</b>	<b>47</b>
Cleaning Up .....	47
Disposal of Waste.....	49
Checking Your Work .....	51
Ongoing Monitoring & Maintenance.....	53
<b>5. Resources.....</b>	<b>55</b>
A. Glossary.....	55
B. For More Information.....	57
C. Getting the Word Out .....	65
<input type="checkbox"/> <i>How Owners and Occupants Can Work Together to Improve Lead-Safety in Homes</i>	
<input type="checkbox"/> <i>Notice Prior to Renovation</i>	
<input type="checkbox"/> <i>Why Lead Safety Makes Sense for Property Owners and Contractors</i>	
D. More About Technical Topics .....	69
<input type="checkbox"/> <i>Respiratory Protection</i>	
<input type="checkbox"/> <i>Testing Dust for Lead</i>	
<input type="checkbox"/> <i>Setting Up a Dust Room</i>	
<input type="checkbox"/> <i>Building a Door Hold</i>	
E. Tool and Supply List.....	75
F. Notes and Special Instructions.....	77
G. Work Checklist and Disclaimer.....	Back Cover

# REMEMBER THESE PRINCIPLES

- 1. ASSUME:** **Paint in Homes Built Before 1978 Contains Lead**  
(Unless a lead-based paint inspection shows it doesn't.)  
**Exposing Anyone to Dust, Especially Children, is Bad**
  
- 2. CHECK:** **Federal, State, and Local Regulations**
  - OSHA has rules for worker safety
  - EPA and your local community have rules for waste disposal
  
- 3. AVOID:** **Creating Dust**
  - Use low dust work practices (for example, mist surfaces with water before sanding or scraping)**Spreading Dust**
  - Cover area under work with durable protective sheeting (plastic or poly)
  - Keep dust contained to immediate work area
  
- 4. PROTECT:** **Occupants, Particularly Children**
  - Keep them away from work area
  - Clean up work site before they return**Workers**
  - Wear proper respiratory protection for lead dust
  - Keep clean
  - Don't take dust home
  
- 5. CLEAN UP:** **After All Work**
  - Clean up is particularly important if painted surfaces were broken or wall cavities were opened
  - Take dust wipe samples to make sure that it is safe for children to return
  
- 6. MAINTAIN:** **A Dry Building**
  - Moisture problems can cause paint failure, building deterioration, and encourage pests**All Painted Surfaces**
  - Well-maintained paint generally does not pose a health risk**Clean and Cleanable Surfaces**
  - Keep floors and painted surfaces smooth
  - Damp mop them often
  - Clean rugs and carpet well

## ROUTINE WORK PRACTICES

The following pictures appear throughout the Guide and refer to specific sections covering these practices.

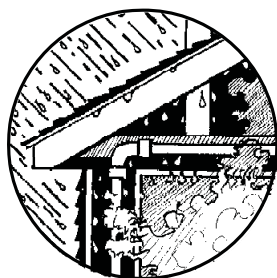

**Correct the Cause of the Problem.** Before work starts, correct the conditions causing damage to the home. See Correcting the Cause of the Problem, p. 7.

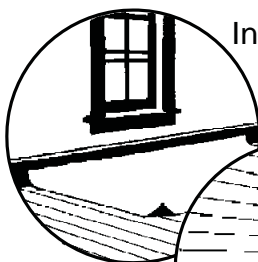

Interior

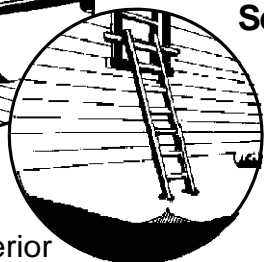

Exterior

**Set Up Work Area.** Set up the work area properly. See Section 2: Set Up the Work Area - Interior & Exterior, p. 13 and p. 15, respectively.

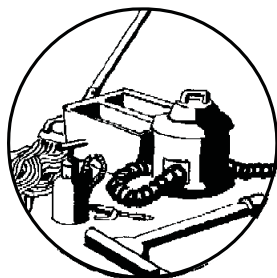

**Clean Up and Clear.** Thoroughly clean up the work area using the procedures described in this guide. Then, take dust wipe samples to see if it is safe for children to return. See Section 4: Cleaning Up, p. 47 and Check Your Work, p. 51.

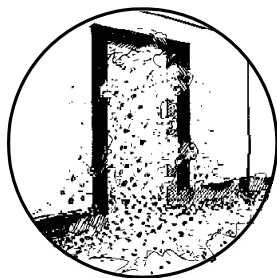

**High Dust Jobs.** Some activities are likely to create high amounts of dust during the job. See Section 3: High Dust Jobs, p. 45 and follow the guidelines in this section to ensure that this work is performed safely.



**Important!!** This symbol points out important details where special attention is needed.

# CORRECTING THE CAUSE OF THE PROBLEM

If a job involves repairs to a damaged paint surface, it is important to correct the cause of the damage, or the damage will occur again. Damaged surfaces that contain lead-based paint represent a health threat to the occupants.



The following conditions are examples of potential causes of damage to painted surfaces. Be sure that the planned work will correct these conditions if they are present.

## Moisture From Outside

Roof leaks; incorrectly installed flashing; defective downspouts and gutters; water collecting in window troughs; puddles of water at foundations; leaking basement walls; wet crawl spaces.

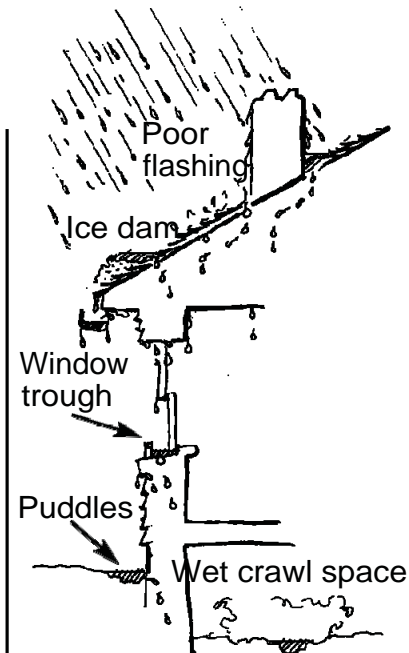

## Moisture From Inside

Attic condensation due to poor ventilation; unvented steam from showers and cooking; leaking plumbing and failed seals around tubs and toilets; condensation in walls; unvented dryers; wet and poorly maintained basements.

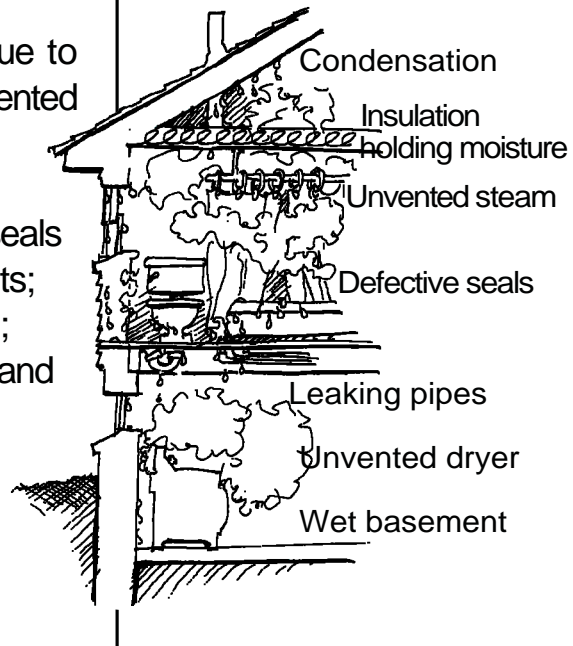

## Rubbing and Impact of Painted Surfaces

Binding doors; unprotected painted walls and trim; and rubbing from opening and closing painted windows.

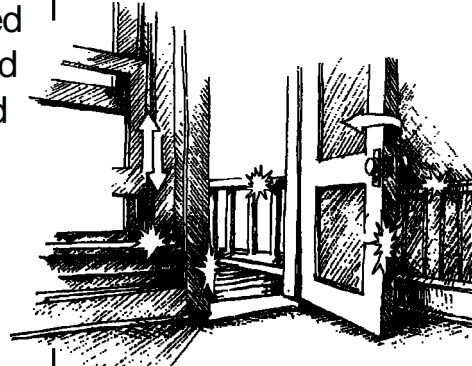

## Places that Collect Dust and Paint Chips

Where feasible, repair or remove places where dust and paint chips may accumulate and can't be easily cleaned (*such as old wall-to-wall carpet and unused items stored in the basement*). If

these places are damp, they may also be home to mold.

Keep flat surfaces (*such as window stools or interior sills and troughs*) clean and cleanable.

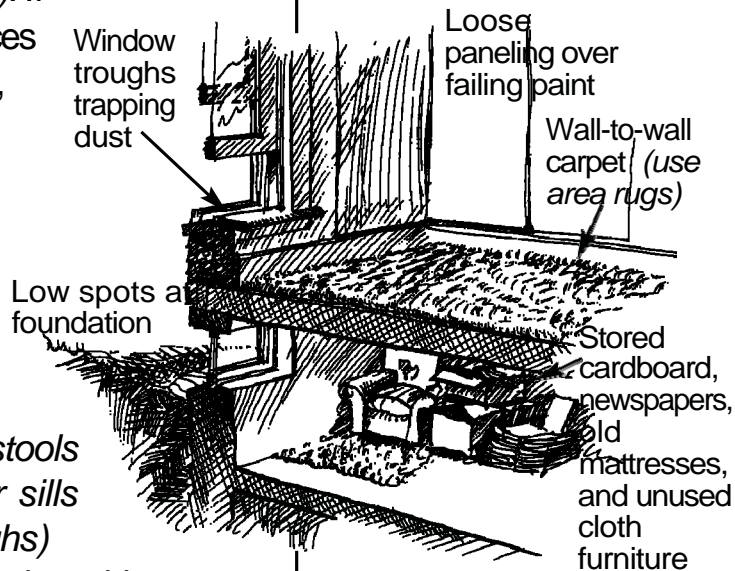

## Structural Damage

Some surface damage may be caused by structural damage such as wood rot, termites, foundation settlement, and foundation shift. These problems must be addressed before surface repairs are made.

# R E S T R I C T E D P R A C T I C E S

**Goal:** Don't use unsafe work methods. Some work methods create such high levels of dust that they must not be used when working on surfaces that may contain lead-based paint.



## **Don't Use Power Sanders or Grinders Without HEPA Vacuum Attachment**

These machines create a lot of dust that can contaminate a building and the ground around a building endangering workers, neighbors, and occupants.

## **Controlled Sanding or Grinding With HEPA Vacuum Attachment Is Acceptable.**

If the sanding or grinding machines are "shrouded," which means surrounded with a barrier that prevents dust from flying out around the perimeter, AND attached to a HEPA vacuum, they can be used. Because some dust may still blow out around the perimeter, workers near the machine should wear half-mask respirators rated by NIOSH as N100 (or HEPA) at a minimum. Also, the work area must be completely isolated if the machine is used inside (see Section 3: High Dust Jobs, p.45). Because these tools can create high levels of dust and require additional precautions, their use is beyond the scope of this guide.

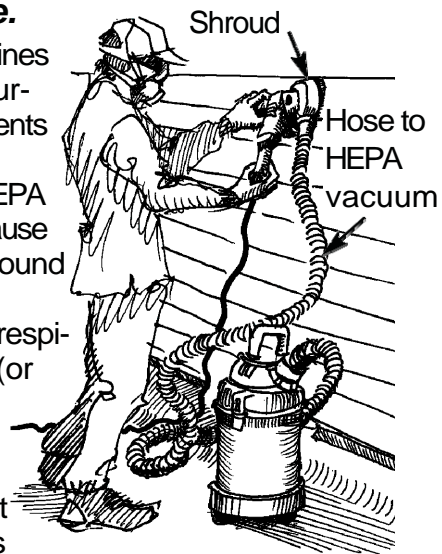

## **Don't Use Open Flame/High Heat Removal of Paint.**

There is no acceptable use of an open flame torch or high temperature heat gun (above 1100 degrees F) to remove paint.

- It produces toxic gases that a HEPA dust canister on a respirator cannot filter out on its own (a second, organic filter is necessary).
- It creates high levels of very toxic dust that is extremely difficult to clean up.
- It can burn down a house.

## **Do Use a Heat Gun on Low Setting.**

A heatgun set below 1100 degrees F may be used with caution. It is recommended for small areas only, such as the edge of a door, the top of a window stool, or the friction surface of a window jamb.



***Don't Use Paint Strippers Containing Methylene Chloride.***

Many paint strippers are potentially dangerous. Strippers containing methylene chloride should not be used because this chemical is extremely toxic and is known to cause cancer.

***Other Chemical Strippers with Appropriate Precautions Are Acceptable.***

Chemical strippers without methylene chloride are safer to use, as long as the precautions printed on the container are followed. Take extra precautions to mask areas near stripping.

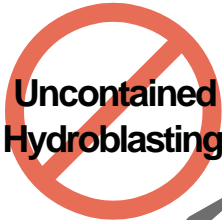

***Don't Use Uncontained Hydroblasting.***

Removal of paint using this method can spread paint chips, dust, and debris beyond the work area. This result makes it difficult to clean up these hazards at the end of the job.

***Contained Pressure Washing Is Acceptable.***

Removal of paint using contained pressure washing within a protective enclosure to prevent the spread of paint chips, dust, and debris may be done. Because this method requires additional precautions that are beyond the scope of this guide, it should only be used by certified lead abatement workers.



***Don't Use Uncontrolled Abrasive Blasting.***

This work method can also spread paint chips, dust, and debris beyond the work area. This result makes it difficult to clean up these hazards at the end of the job.

***Contained Blasting Is Acceptable.***

Contained abrasive blasting within a protective, locally exhausted enclosure to prevent the spread of paint chips, dust, and debris may be used. Because this method requires additional precautions that are beyond the scope of this guide, it should only be used by certified lead abatement workers.



***Avoid Extensive Dry Scraping or Sanding.***

Extensive dry scraping or sanding create large amounts of paint chips, dust, and debris that are hard to contain.

***Use Wet Methods or Limited Dry Scraping and Sanding.***

Mist surfaces before scraping and sanding. Continue to mist while working. Dry scraping or sanding of very small areas (for example, around light switches or outlets) may be done if flat surfaces below these areas are covered with protective sheeting. These methods should be avoided on areas larger than 2 square feet per room, and workers must have adequate respiratory protection.

# K E Y   S T A G E S   O F   A   J O B

Quality work requires thinking through the job from start to finish. Here are the basic stages of the jobs described in this guide.

<b>Before Starting</b>	<ul style="list-style-type: none"><li>• Find the causes of damage</li><li>• Prioritize work</li><li>• Hand out lead hazard information pamphlet (see note below)</li></ul>
<b>Work</b>	<ul style="list-style-type: none"><li>• Set up work area<ul style="list-style-type: none"><li>— Separate work space from occupied space</li><li>— Isolate high dust areas</li></ul></li><li>• Correct cause(s) of problem(s)</li><li>• Complete the job using safe work practices, such as those shown in this guide</li></ul>
<b>Finish the Job</b>	<ul style="list-style-type: none"><li>• Clean up thoroughly</li><li>• Dispose of waste safely</li><li>• Check quality of work and correct problems</li></ul>
<b>Maintain the Work</b>	<ul style="list-style-type: none"><li>• Educate occupants about risks from lead-based paint</li><li>• Maintain a safe and healthy home</li></ul>

## Renovation Notice About Lead Safety

**Note:** Federal law requires that owners and occupants of a house or apartment built before 1978 receive the pamphlet *Protect Your Family From Lead In Your Home* prior to the start of renovation work. The requirement applies to any work that will disturb a painted surface larger than 2 square feet when the work is done by:

- Contractors who have been hired to do any kind of work. Among others, this can apply to painting, drywall, and electrical trades.
- Owners of rental properties who have work performed by maintenance staff.

See p. 67 for more information about this requirement.



## SET UP THE WORK AREA — INTERIOR

### Restrict Access

- Ask occupants to leave the room where work will be done.
- Have them stay out until final cleanup.
- Place “DO NOT ENTER” tape across doorway or post sign.



**Caution:** If the work will create a large amount of dust, follow the guidelines in Section 3: High Dust Jobs, p. 45.

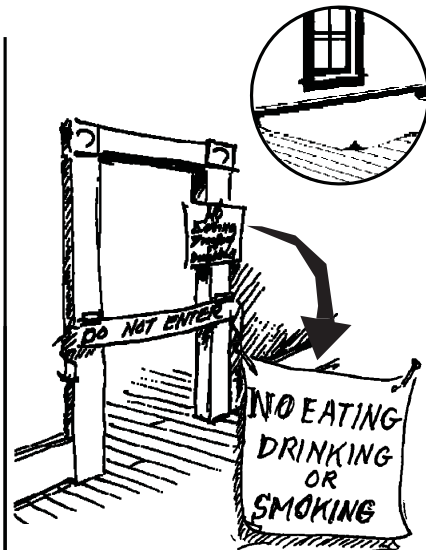

### Protect Floor

- Place protective sheeting on floor extending about 5 feet from the work area.
- Tape protective sheeting to the baseboard under work area using masking tape (or durable tape where masking tape doesn't work).

Use protective sheeting, such as poly

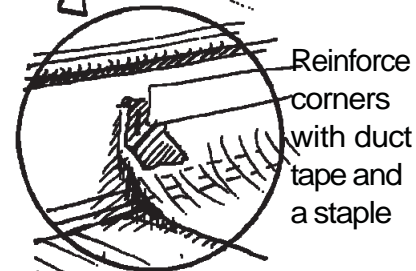
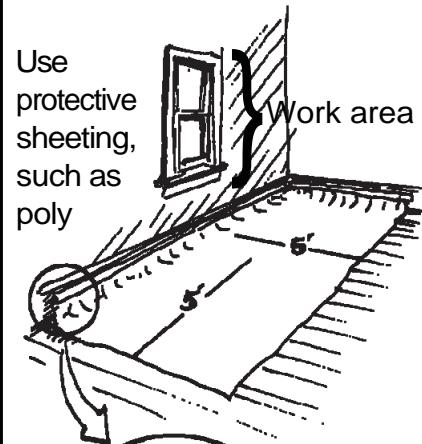

### Protect Furnishings

- Remove drapes, curtains, furniture, and rugs within 5 feet of work area.
- Cover any furniture within 5 feet of work area that cannot be moved.

Cover furniture with protective sheeting



### Stock the Work Area

- Put all necessary tools and supplies on protective sheeting before beginning work to avoid stepping off the protective sheeting.

BEFORE YOU START WORK

## Tracking

- To avoid tracking dust off the protective sheeting, wear non-skid shoe covers on protective sheeting and remove them each time you step off the protective sheeting.

**OR**

- Wipe both top and bottom of shoes with a damp paper towel each time you step off the protective sheeting.

**OR**

- Clean off shoes using a tack pad (a large sticky pad that helps remove dust).

**OR**

- Remove shoes every time you step off the protective sheeting.

## Set Up Dust Room (Optional)

- When working on components that can be moved, such as doors and window sashes, consider setting up a dust room. A dust room is an area isolated from occupied areas where workers can do dust generating work. The door of the room is covered with a flap and the floor is covered with protective sheeting. See Section 5D: Setting Up a Dust Room, p. 73.

- Using a dust room contains dust and paint chips, and makes cleanup easier. It also helps protect occupants, as well as other workers.

Shoe  
cover

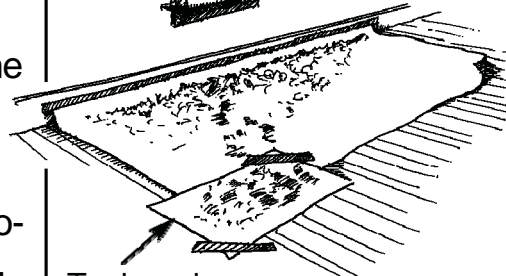
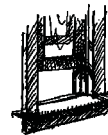
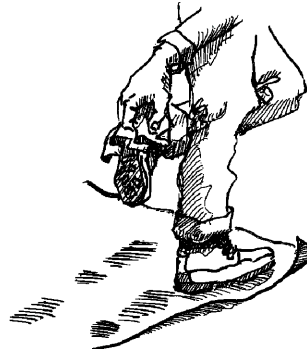

Tack pad



# SET UP THE WORK AREA—EXTERIOR

## Protect Ground

- When working on the ground floor, lay protective sheeting 10 feet from work surface or as space permits. When working on the 2nd story or above, extend the sheeting farther out.
- Vertical shrouding on scaffolding should be used if work is close to a sidewalk, street, or another property, or the building is more than three stories high.



**Important:** Covering the ground protects the soil from contamination by lead-based paint chips and dust.

## Attach Protective Sheeting to Wall

- Protective sheeting can be taped and/or stapled to wood siding or ribbon board. A wood strip may need to be attached to a masonry wall.

## Build Curb

- Build a curb around work perimeter when a sidewalk or another property is near, or when wind may blow debris off protective sheeting.



**Caution:** This may pose a tripping hazard.

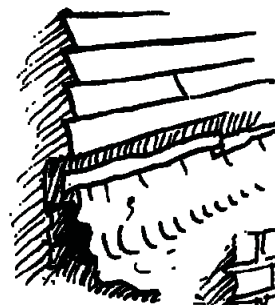
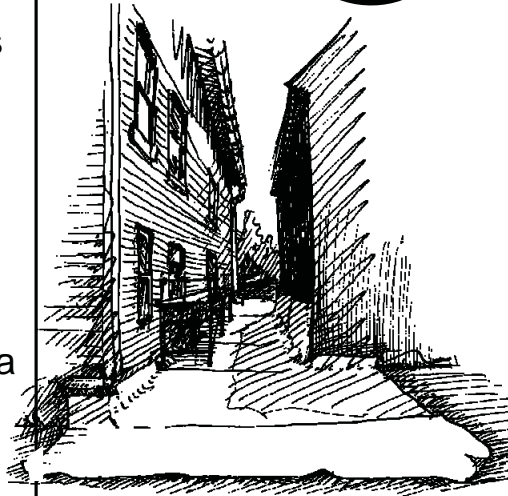
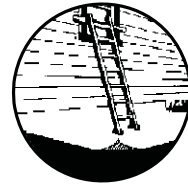

Duct tape and staple protective sheeting

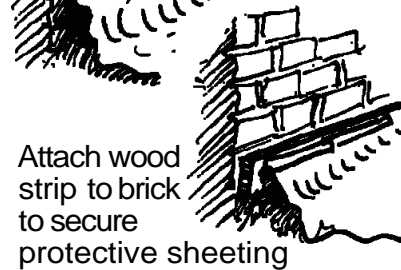

Attach wood strip to brick to secure protective sheeting

Curb edge of protective sheeting

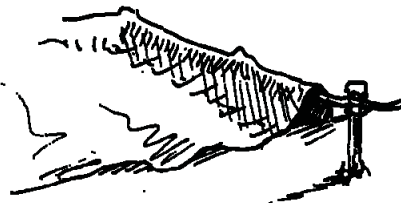

BEFORE YOU START WORK

## Cover Windows and Doors

- All windows and doors within 20 feet of the work area must be closed. If they cannot be closed, seal with protective sheeting during work.
- If an entrance must be used that is closer than 20 feet, place a shroud above and on the sides of the entrance.

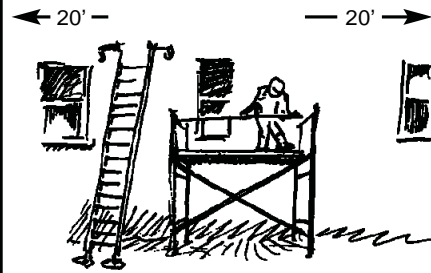

## Use Ladder Safely

- Don't use a metal ladder near power lines.
- Check feet and rungs of ladder to make sure they are sound.
- Place the base of the ladder at a distance from the wall using a height to base ratio of 4:1.
- Ladder should extend 3 feet past the top of the surface area where work will be done.
- If using protective sheeting to cover the ground, cut slots in the sheeting and place the ladder feet directly on the ground—not on top of the protective sheeting.
- Tie off the top of the ladder, where possible.
- If the work is taking place at heights above 10 feet, tie off the ladder and secure yourself with a lanyard and harness.

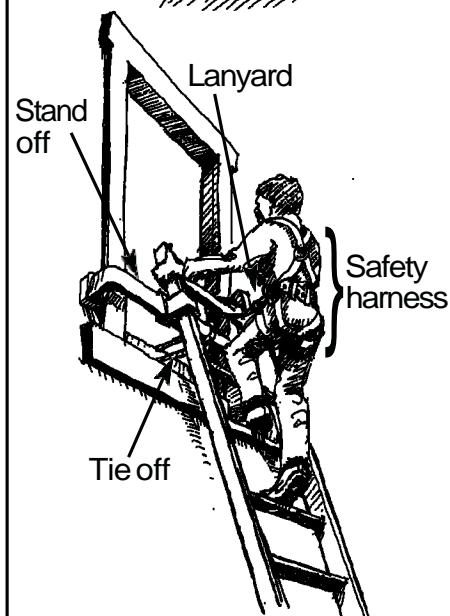
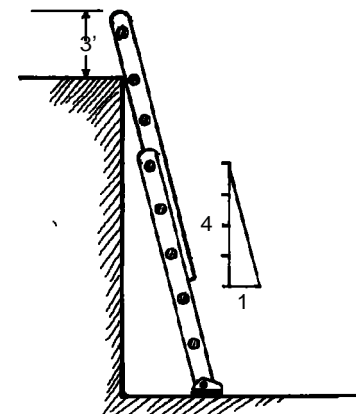
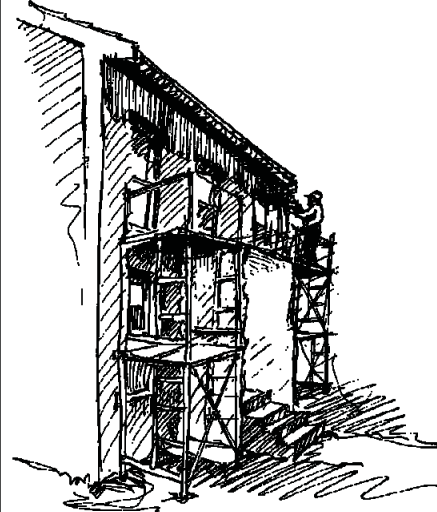

# W O R K E R P R O T E C T I O N

## Protect Your Eyes

- Always wear safety goggles or safety glasses when scraping, hammering, etc.

## Keep Clothes Clean

**OR**

## Use Disposable Covers

- At end of work period, remove dusty clothes and/or vacuum off dust. Wash them separately. Do not use compressed air to blow dust off clothing.

- Wear disposable protective clothing covers. Disposable protective clothing covers can be stored in a plastic bag and reused if fairly clean and there are no rips. Small tears can be repaired with duct tape.
- Wear painter's hat to protect head from dust and debris.

## Wear Respiratory Protection

- When work creates dust or paint chips, workers should wear at least a NIOSH-approved respirator for lead work. See Section 5D: Respiratory Protection, p. 69.

## Post Warning

- Post sign and avoid eating, drinking, or smoking on site.

## Wash Up

- Wash hands and face each time you stop working.

Disposable suit & shoe covers

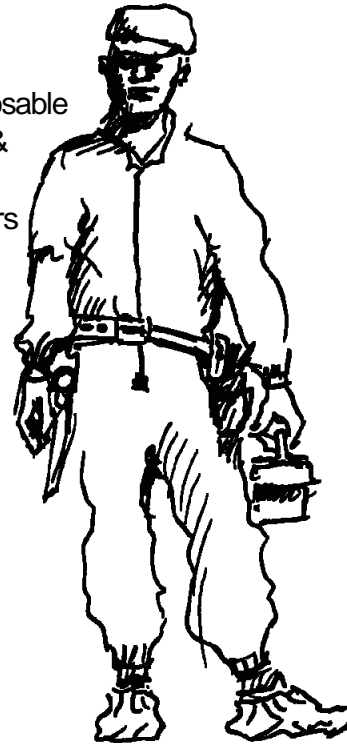

Sign at work site entrance

BEFORE YOU START WORK



# INTERIOR SURFACE PREP

**PROBLEM** A wall or ceiling is sound, but has holes, uneven surfaces, or flaking and peeling paint.

**SOLUTION** Prepare wall or ceiling to create a sound, intact surface for painting. Use methods that create a minimum amount of dust.

## Set Up

- See Section 2, p. 13.

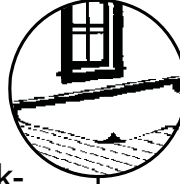

## Remove Deteriorated Paint

- Wet scrape any loose, peeling, or flaking paint.

## Fill and Patch Holes

- If removal of damaged edges is necessary, mist surface before removal.
- Skim and fill holes and cracks less than 1/16 inch wide with a non-shrinking spackle compound.
- If sanding is necessary to feather edge, use wet abrasive sponge or wet-dry sandpaper with water.

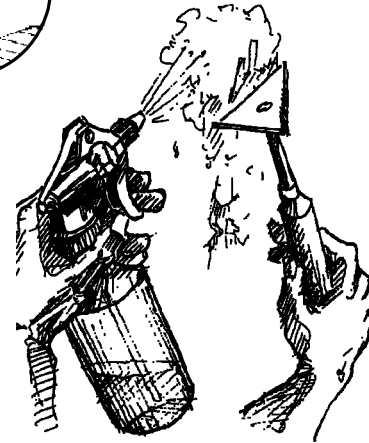

## Prep Surface

- Clean wall, particularly in kitchen area.
- De-gloss surfaces as necessary (use liquid sandpaper or wet-dry sandpaper with water).



**Important:** Allow surface to thoroughly dry before priming.

- Prime surface using high-grade primer.
- Apply top coat. Use one or two coats as necessary.

## Clean Up and Clear

- See Section 4, p. 47.

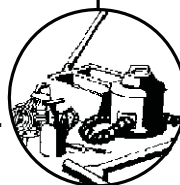

## PROBLEM SURFACE PREP CONT'D

but most of the surface is sound.

A wall or ceiling has cracking, peeling, or alligating paint,

**SOLUTION** Use a coating designed for longer durability than paint. Some of these coating systems include mesh.

### Set Up

- See Section 2, p. 13.



### Liquid Coating

### Test Surface

- Where a long-lasting system (sometimes called encapsulant) is to be brushed, sprayed, or rolled, surface preparation is very important.
- If an encapsulant is used, use one that is approved by a state government. If your state does not have a list of approved encapsulants, it is recommended that you check with a state that does. Contact the National Lead Information Center at 1-800-424-LEAD for the telephone numbers of states with lists.
- A sample area should be tested before application. Follow manufacturer's instructions exactly.

### Apply System Base Coat

- Apply system base coat with a high nap (approximately 3/4 inch) roller. Follow the product instructions.

### Mesh System

### Apply Mesh

- Where there is extensive cracking or alligating, consider using a system that includes mesh because it can add strength and durability.
- Cut the mesh leaving a 2 inch overlap at ceiling and baseboard.
- Install so that mesh is plumb.

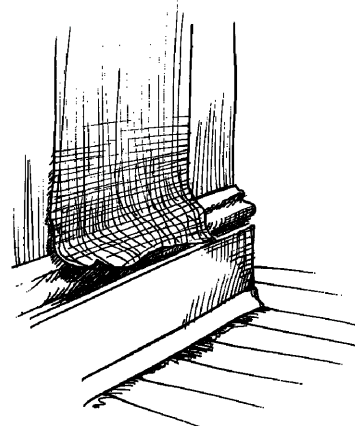
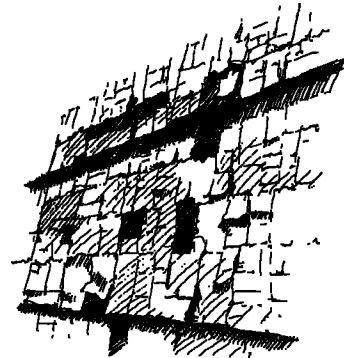

**Important:** For mesh systems, follow manufacturer's instructions exactly.

## Apply Mesh Cont'd

- Press mesh into the base coat with a wall-paper brush, spackle knife, or roller.
- Overlap seams by 1 inch. Cut down the center of the seam and remove the 2 waste strips. Let seams butt against each other.
- Using a spackle knife, press the mesh at the bottom and top. Then cut off the excess.
- Roll on the top coat. Make sure that there is complete and even coverage.
- If there is a risk of further peeling, the top edge of mesh can be reinforced with cove or crown molding, and the bottom reinforced with base cap.

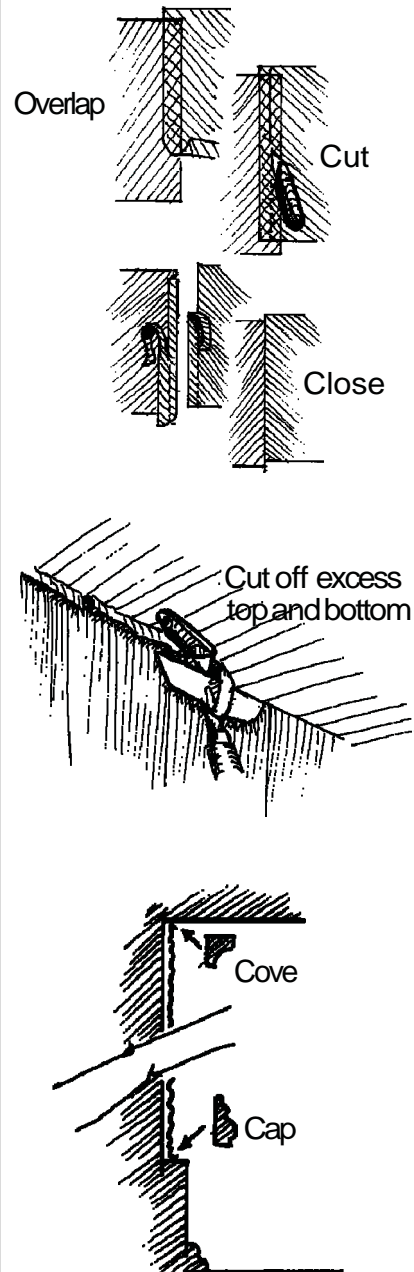

## Clean Up and Clear

- See Section 4, p.47.

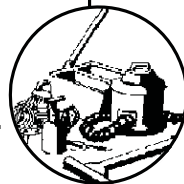

# EXTERIOR SURFACE PREP

**PROBLEM** Exterior wood surface is chipping and peeling and may be painted with lead-based paint.

**SOLUTION** Prepare a sound, intact surface for painting. Use methods that create minimal dust.

## Set Up

- See Section 2, p. 15.



## Clean Surface

- Clean wood with detergent (or lead-specific cleaner) and scrub brush.

## Wet Scrape

- Wet scrape woodwork and siding. Mist small areas frequently to keep down dust. Using a pump sprayer in a knapsack is convenient.

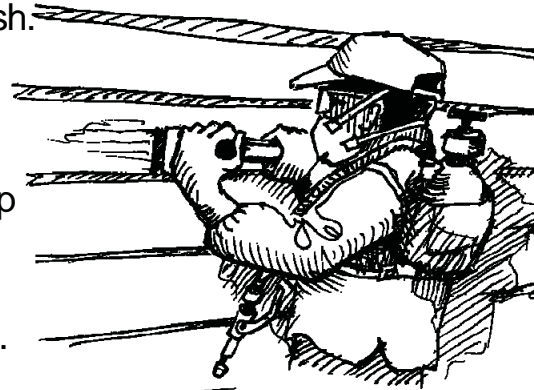

## Mist and Sand

- Wet sand using wet-dry sandpaper or wet sanding sponges. A power sander may be used if attached to a HEPA vacuum, and the worker is wearing respiratory protection.

## Paint

- Prime and paint.

## Clean Up and Clear

- See Section 4, p. 47.

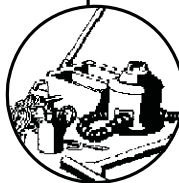

## Dispose of Water

- If you dislodge paint using pressure washing, water must be collected and may need to be tested (see local regulations for water disposal procedures in your area).

# P A I N T R E M O V A L

**PROBLEM** Areas of paint are peeling or flaking or there is evidence that a child has been chewing on a painted surface. An example of a surface accessible to children is the inside nose of a window stool (inside sill).

**SOLUTION** Remove all paint using methods that do minimum harm to the surface, create minimal dust, and are safe for workers.

## Set Up

- See Section 2, p. 13 or p. 15.
- When using chemical strippers, the edge of the protective covering below the painted surface must be tightly fastened to the wall so that the stripper doesn't damage other surfaces.
- Recommendations:
  - Use a second layer of protective sheeting to collect stripping waste. The first layer remains in place to protect surfaces below.
  - For removable components, consider having paint stripped off-site or installing an entirely new component.

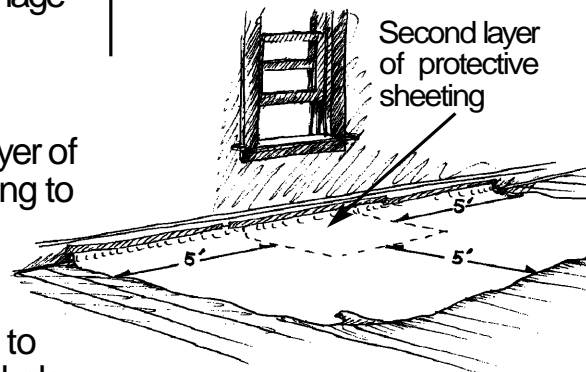
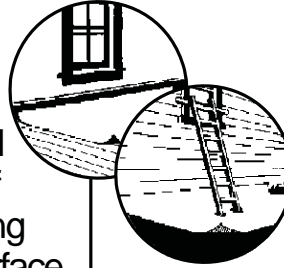

## Chemical Removal

- If a large area of paint is to be stripped, consider hiring a professional.
- Follow the manufacturer's instructions carefully when using chemical paint strippers.



**Caution:** If using a caustic stripper, neutralize the surface according to the manufacturer's directions before applying new paint.

## Chemical Removal Cont'd

- After stripping paint from wood, a paint residue will remain in the wood. Use caution when sanding the bare wood because it may contain lead residue.



## Hand Stripping

- Paint can also be removed with a paint scraper. Be sure to mist areas where paint is to be removed. Using a hand plane removes all paint and all residue. It also creates very little dust.

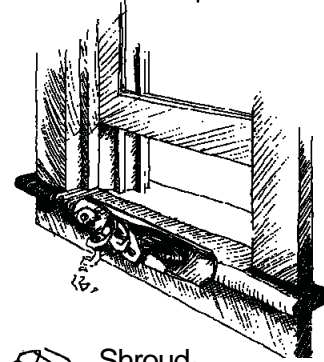

## Mechanical Stripping

- When using power tools, such as sanders or grinders to remove or feather paint, make sure the tool is shrouded and attached to a HEPA vacuum. Respiratory protection is still necessary.

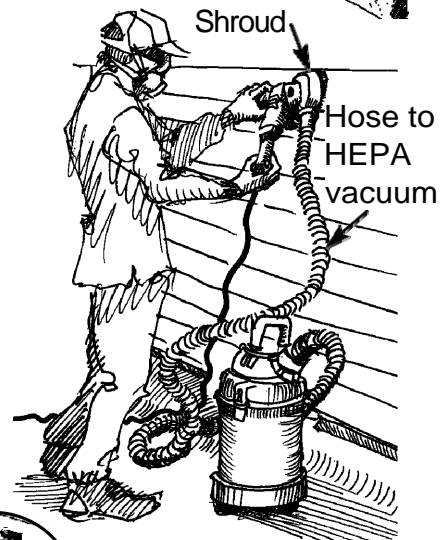

**Caution:** High dust potential.



## Heat Stripping

- When using a heat gun to remove paint, be sure the temperature setting is kept below 1100 degrees F.

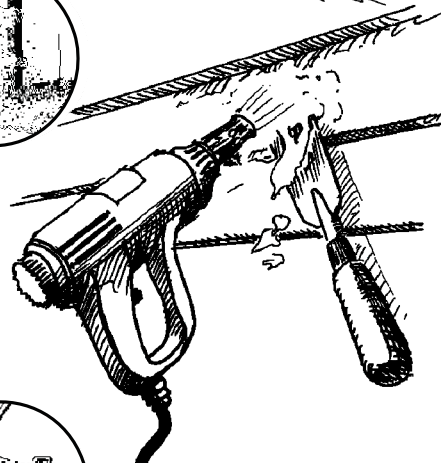

## Clean Up and Clear

- See Section 4, p.47.

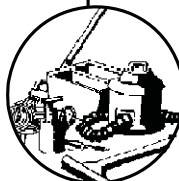

# DAMAGED INTERIOR WALL OR CEILING

**PROBLEM** Wall or ceiling area is too badly damaged to repair, and demolition would create a large amount of dust.

**SOLUTION** Install a new durable surface over the damaged area using methods that create little dust and do not require demolition.

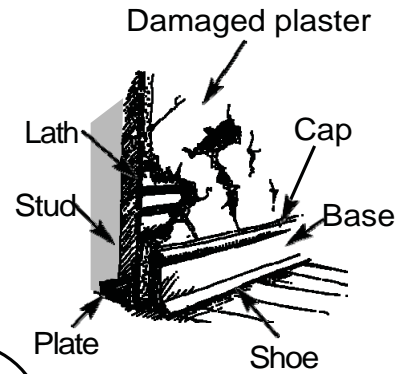

## Set Up

- See Section 2, p. 13.

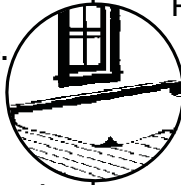

## Cover With Drywall

- Mechanically fasten drywall or veneer board through damaged plaster to studs.
- Seal the perimeter, particularly the bottom edge.

### Drywall laminate sits on old base

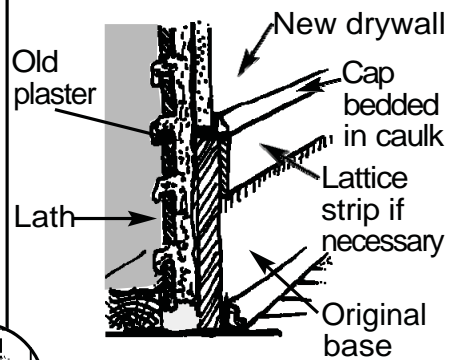

## On Base

- Avoid removing existing base.



**Caution:** High dust potential.

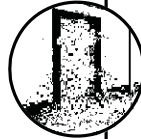

### New base over drywall laminate

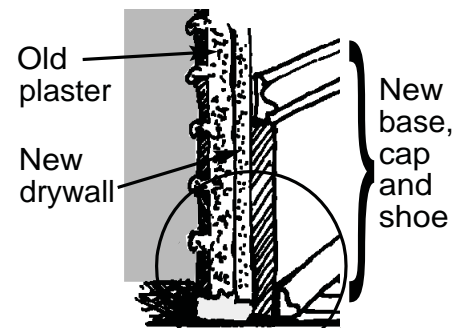

## Behind Base

- Where base will be replaced, bed the new base in bead of caulk on the back and bottom. Then, bed shoe molding in a bead of caulk to seal.

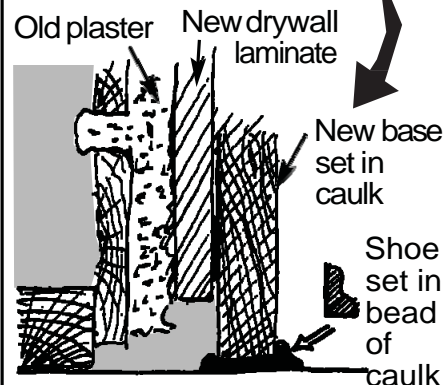

### Install Wainscoting

- Where bottom 3 or 4 feet of wall is damaged beyond repair, the wall can be enclosed with wainscoting. The wainscoting can be installed above the existing baseboard.
- Bed the lower edge in a bead of caulk with a trim piece also bedded in caulk.
- Finish top with cap molding.

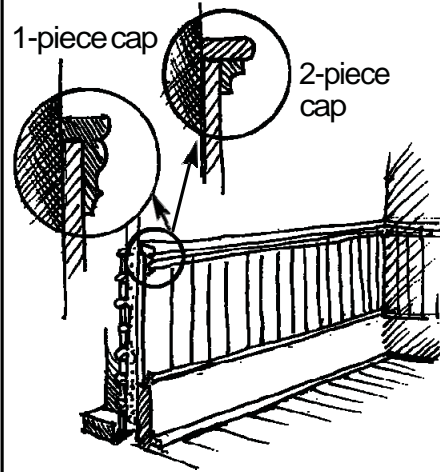

### Repair Holes in Ceilings

- When laminating drywall to ceilings, it is critical to screw into joists, not lath.
- Old joists may be irregularly spaced, so each joist center must be located.
- A drywall dagger can be used to find the joist edge, as can a heavy gauge wire pushed through the plaster.
- The drywall edges should be taped and spackled.
- If walls will not be spackled, perimeter edges can be finished with "J" channel bedded in a bead of caulk.

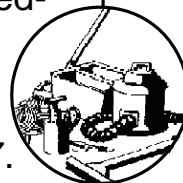
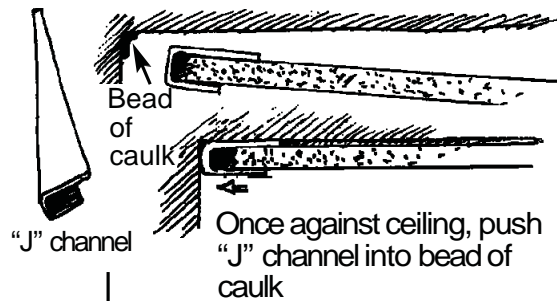
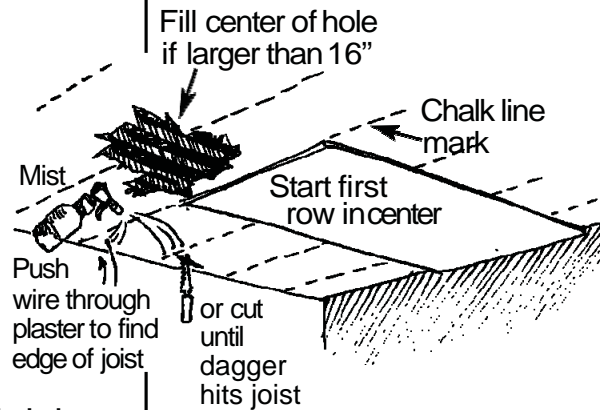

### Clean Up and Clear

- See Section 4, p.47.

# DETERIORATED EXTERIOR SURFACES

## PROBLEM

An exterior painted surface is badly damaged.

## SOLUTION

Whenever possible, repair the surface, prep, prime, and paint exterior trim and siding, and then maintain the surface. This method is the preferred approach.

When a surface is too badly damaged to repair, install vinyl or aluminum siding, or aluminum wrap to create a safe, durable covering that protects the surface and does not cause further deterioration.

*Note: Siding must be installed correctly or it may lead to wood rot and/or interior paint failure. Siding may also become home to insects and mold. Correct installation is critical in both hot and cold climates.*

### Cover Deteriorated Surface With Siding

#### Set Up

- See Section 2, p. 15.



#### Install Siding

- Carefully follow the manufacturer's instructions for installing siding over an existing surface.
- Use a styrene backboard with an R-value of at least R2.
- Take care to properly install flashing, especially at horizontal trim and window and door heads.
- The siding system must be well vented but sealed at the bottom to prevent flaking and peeling paint from falling from behind the siding to the ground.
- Be sure that water can drain out.

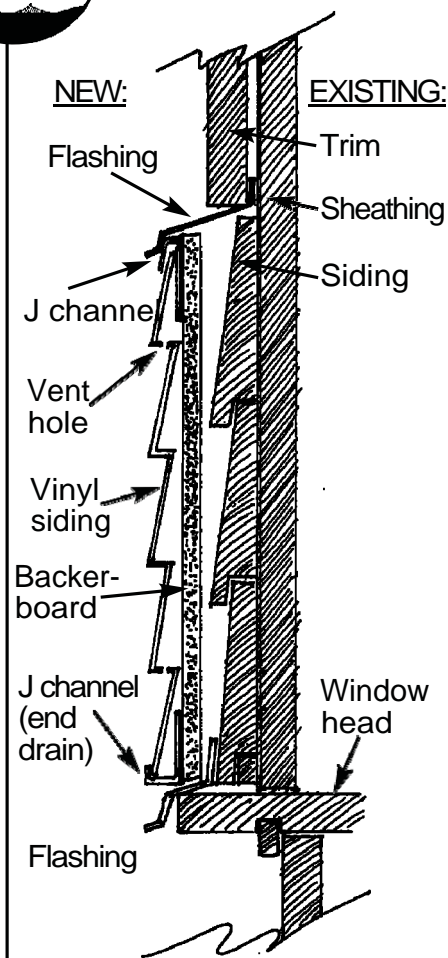

## DOING THE WORK



**Important:** *The entire home should be well ventilated to prevent moisture build-up that can cause structural damage and/or paint failure.*

### **Clean Up and Clear**

- See Section 4, p. 47.

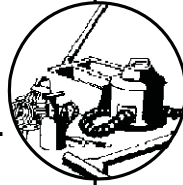

# S T I C K I N G W I N D O W

**PROBLEM** Window sticks, and paint on window is flaking.

**SOLUTION** Remove window, scrape or plane, repaint, and reinstall, OR install a new window.

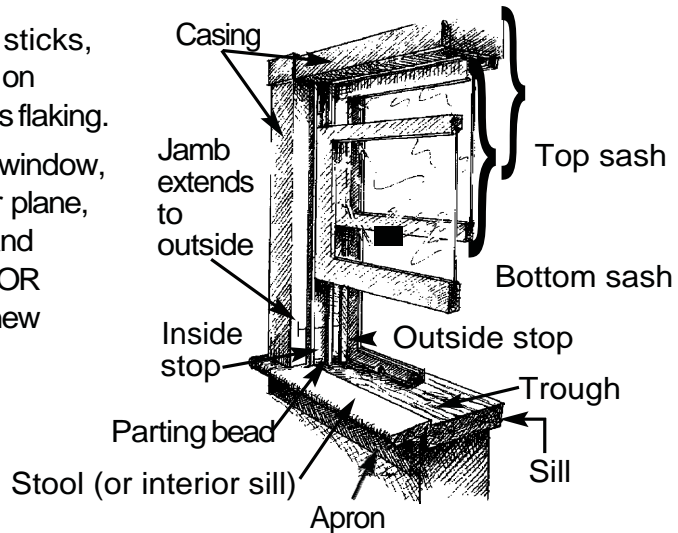

## Set Up

- See Section 2, p. 13.

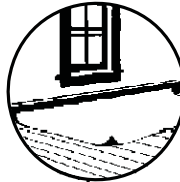

## Loosen Painted Sashes

- If window is painted shut, mist and cut window joint with utility knife. Then open joint between sash and stop with a "window opener." Mist while working.

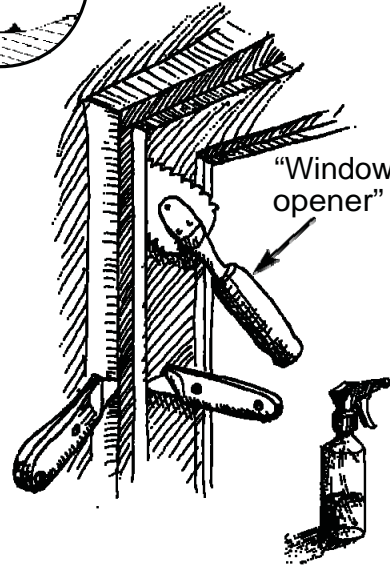

## Remove Inside Stop Molding

- Mist and remove stop molding from sides and head. Dispose of properly unless it has historic value.

## Remove Bottom Sash

- If counterweight cord or chain is attached to the sash, knot it or tie it to a stick when removing from sash so it does not get pulled into the weight compartment.



## Remove Top Sash

- Mist and remove parting bead. Then remove the top sash.

## Wet Scrape or Plane

- Set sash on a work bench, clamp, and wet scrape all surfaces. Or use a power planer attached to a HEPA vacuum.



**Caution:** High dust potential. This work can be done in a dust room. See Section 5D: Setting Up a Dust Room, p. 73.

Wet scrape these ridges of paint

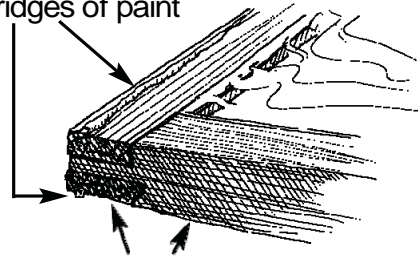

Seal this bottom edge very well, particularly the end grain. Use linseed oil or other sealant.

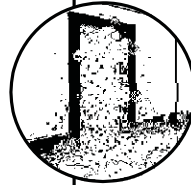

## Repair, Reglaze, Seal, and Paint

- Reglaze and repair as necessary. Wet sand, prime, and paint sash and jamb. Seal, but do not paint sash edges.



**Important:** Seal bottom edge of sash, particularly end grain.

## Repair and Paint Jamb

- Repair jamb if necessary.
- To prevent dust and chips from falling outside the window, install a scoop of protective sheeting.
- Then wet scrape, prime, and paint.

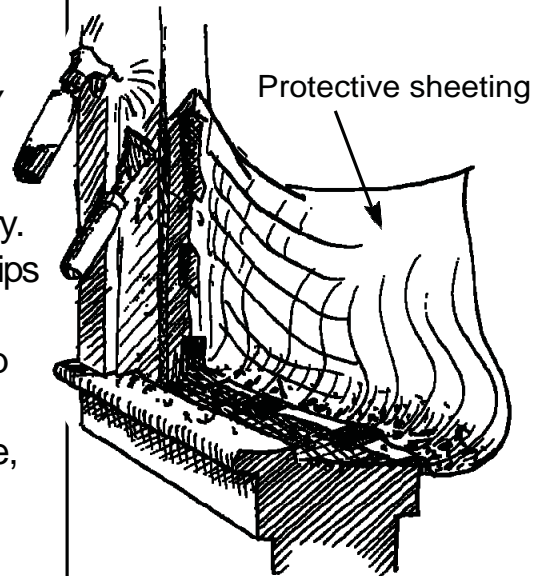

## Reinstall Sash

- Reinstall sash with new or wet scraped and repainted stop and parting bead.

## Clean Up and Clear

- See Section 4, p.47.

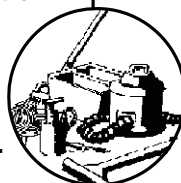

# L O O S E W I N D O W

**PROBLEM** Loose sashes (lower and upper) do not operate smoothly, and they allow heat loss. Also, sashes rubbing against a painted jamb create paint dust.

**SOLUTION** Install sashes in window compression jamb liner to seal window and allow sashes to move easily without rubbing against jamb. If sashes or window components are badly deteriorated, replace window.

## Set Up

- See Section 2, p. 13.

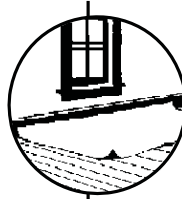

## Install Window Jamb Liners

### Remove Sashes and Paint

- Follow directions on pages 29 and 30.

### Cut Jamb Liners

- Cut liners to fit in jamb (1/4 inch short of dimension). If pulley system is being saved, cut off directly below pulley.

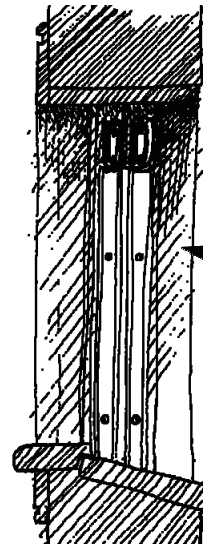

### Install Jamb Liners

- Press jamb liners onto sash.
- Attach jamb liners with brass screws on top and bottom of each side.

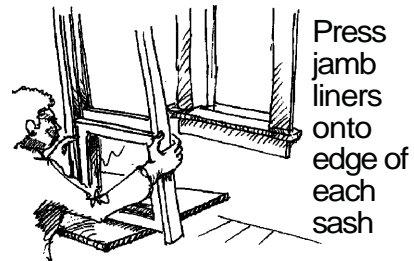

Slide sashes and liners into jamb and put two brass screws into each side

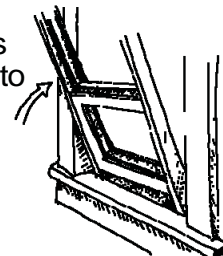

## Install Stop Molding

- Install new inside stop molding tight against jamb liner.

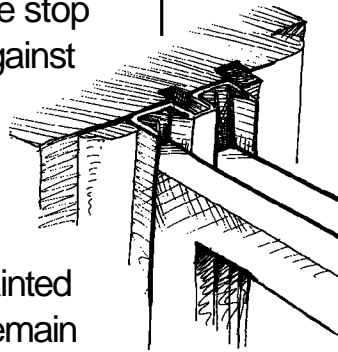

- If top sash is painted shut and is to remain fixed, adjust the above steps as follows:
  - Cut away flange between channels of jamb liner.
  - Leave parting bead intact and install bottom sash as above.

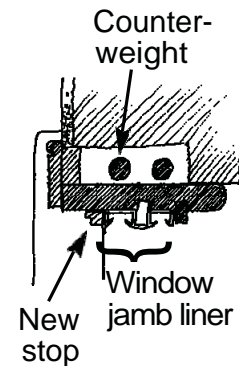

Cut flange of jamb liner with plexiglass cutter.



## Replace Sash/Window

### Choose an Option

- If the sashes or other components are too badly deteriorated to save, consider one of the following options:
  - Install new sashes in tilt-in jamb liners.
  - Replace sashes, stops, and parting bead with a vinyl or aluminum window unit.
  - Replace entire window including jamb casing, stool, and apron.

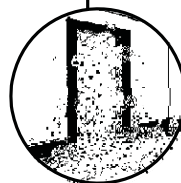

### Clean Up and Clear

- See Section 4, p.47.

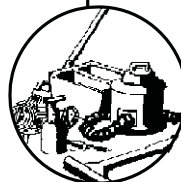

# WINDOW WON'T STAY OPEN

**PROBLEM** Window sash is loose and won't stay up without support. Propping the window open presents a danger to occupants, particularly children. When a window jamb liner is used, it may not be sufficient to keep the window open. (See page 31.)

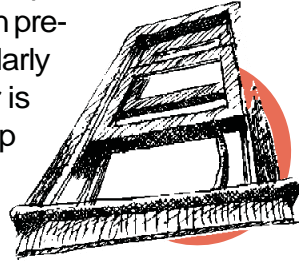

**SOLUTION** Repair counterweight system or install hardware so the window will stay open securely, or replace window.

## Set Up

- See Section 2, p. 13.

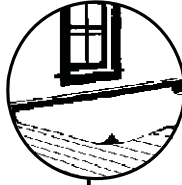

## Option #1: Reinstall Counterweight System

### Open Counterweight Panel

- Find top of panel. Mist and scrape paint from top edge to find screw or nail holding in panel. Remove screw and pry off panel.

### Vacuum

- Vacuum weight compartment with HEPA vacuum.

### Remove Counterweight System

- Remove old rope or chain from counterweight and edge of sash.

### Reinstall Counterweight System

- Cut chain so weight is above bottom of weight compartment when open and weight is below pulley when closed.

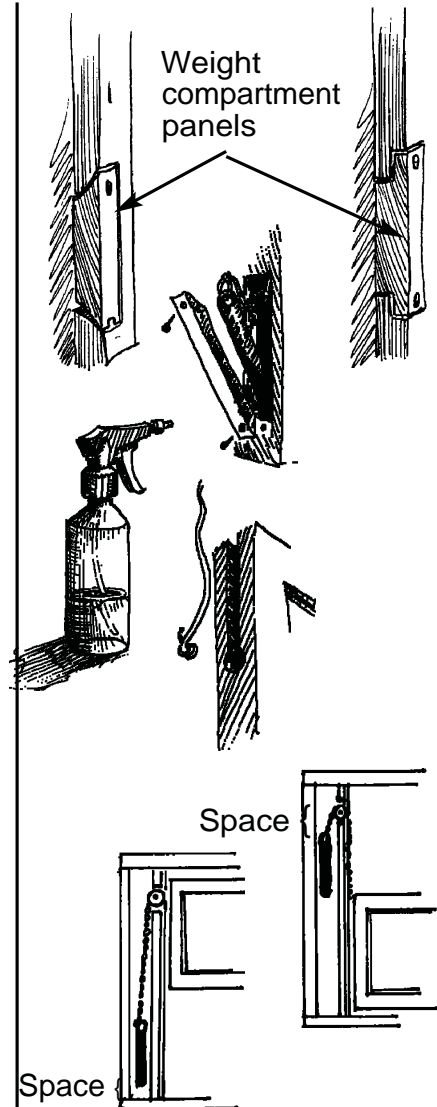

**Reinstall Counter Weight System Cont'd**

- Drop chain over pulley into weight compartment, pull out through panel opening, and attach to weight.
- Attach other end to edge of window sash using spring fixture. You may want to secure chain with fence staple.

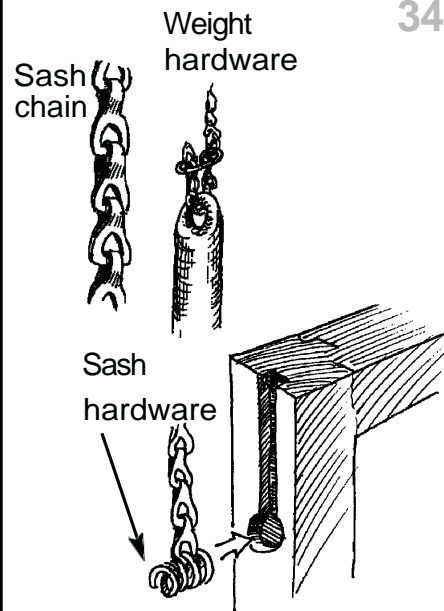

**Option #2: Install Spring Clips**

**Install Spring Clips**

- Screw spring clips on to window as directions indicate. (2 styles shown.)

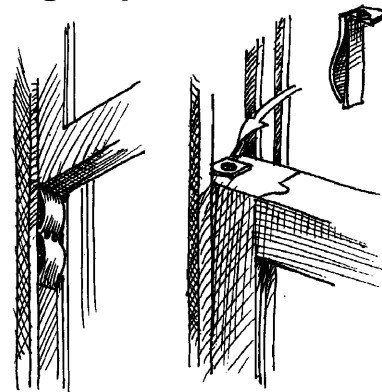

**Option #3: Install "Hold Open" Hardware**

**Install Slide Bolt**

- Screw slide bolt to bottom of window sash. Tap bolt to mark where you want to drill holes for bolt. Drill holes in inside stop at 3 or 4 points.

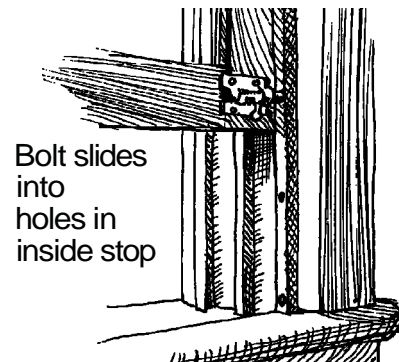

**OR**

**Attach Hardware**

- Attach hardware that uses spring to press against stop. To move sash, press lever. Release lever when window is at desired height.



**Clean Up and Clear**

- See Section 4, p.47.

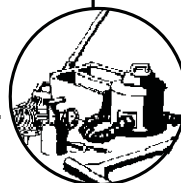

# DETERIORATED WINDOW TROUGH

**PROBLEM** Storm window traps water behind the frame causing paint deterioration and damage to the sill.

**SOLUTION** Drill a drain hole through bottom of the storm windowframe.

**PROBLEM** Window trough surface is damaged and difficult to clean.

**SOLUTION** Install smooth and cleanable surface in windowtrough.

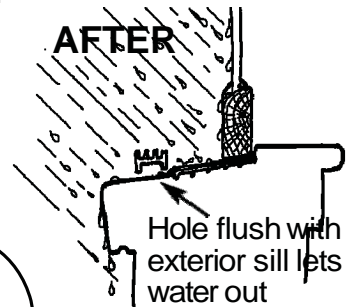
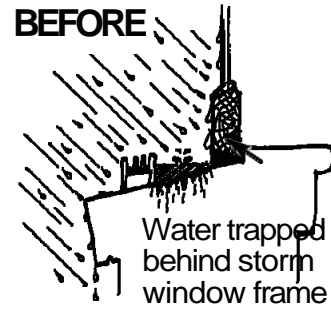

## Set Up

- See Section 2, p. 13.

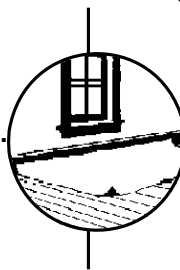

## Drill Drain Hole

## Drill

- To allow drainage, drill 2 holes through frame of storm window flush with sill. Drill holes approximately one quarter of the way from both sides. First, drill a 1/8 inch pilot hole, then the 3/8 inch hole.

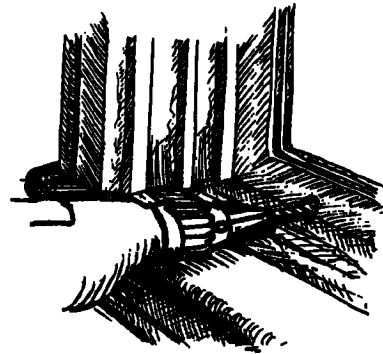

## Dent

- If flashing is installed in window trough and covers any part of the drain hole, run awl through drain hole. Tap with hammer to form dent in flashing to drain out water.

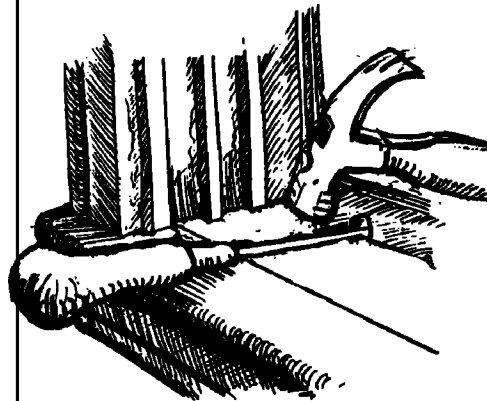

## Cover Trough with Flashing

- Wet Scrape**
- To make surface flat, wet scrape high points and remove any fasteners from trough.



- Cut**
- Cut flashing 1/4 inch shorter than the width and length of trough.

- Chisel or Notch**
- To allow flashing to fit tight to jamb, drive chisel under parting bead and outside stop — or notch each side of the flashing at these two points.

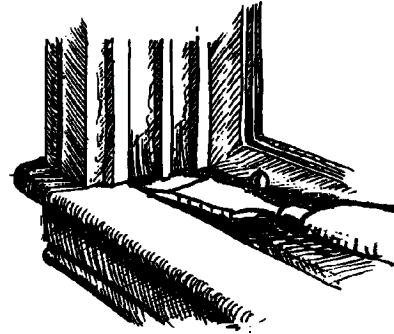

- Check Fit**
- Then slide flashing in to check fit. Remove and trim if needed.

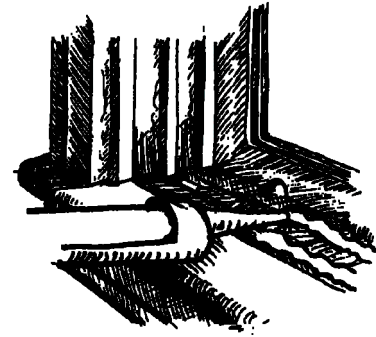

- Fasten**
- To fasten flashing, run bead of adhesive caulk around perimeter of trough.

- Install Flashing**
- Bed flashing in adhesive caulk bead and press down.

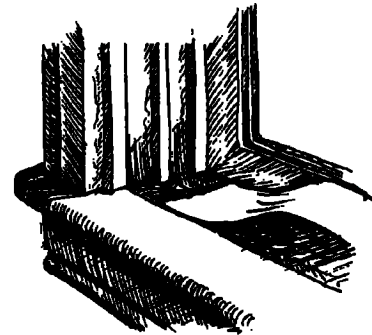

- Seal**
- Run a bead of caulk around perimeter of flashing. If necessary wipe off excess caulk with damp cloth. Try not to smear caulk on face of flashing.

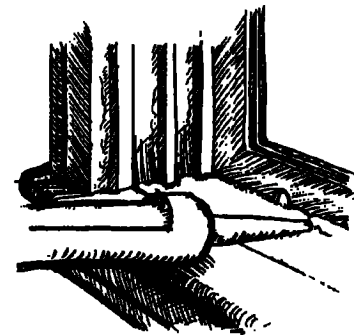

**Important:** Do not cover drain hole with caulk.

**Clean Up and Clear**

- See Section 4, p.47.

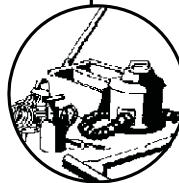

# DOOR NEEDS ADJUSTMENT

**PROBLEM** Edge of door is crushing against jamb on hinge side; or door is rubbing on latch side because hinges are loose. When paint on a door rubs or is crushed, dust and paint chips can result.

**SOLUTION** Adjust the door so that it opens and closes without damaging painted surfaces.

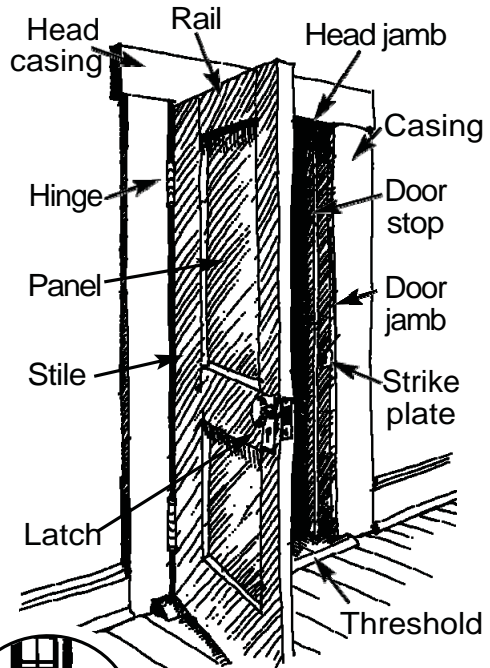

## Set Up

- See Section 2, p. 13.



## Check Door

- Grasp knob and try to move door up and down. If hinges are loose, door will move.

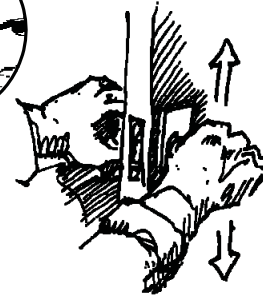

## Remove Screws

- Remove screws that are most loose, but not all screws, so door remains hung.
  - Clear paint from screw notch with hammer and small screwdriver.
  - Unscrew. If screw head is stripped, use screwdriver bit in a brace.



## Fill Hole

- Drive 3/16 inch or 1/4 inch dowel into screw holes as necessary to fill each hole. Cut dowels flush.

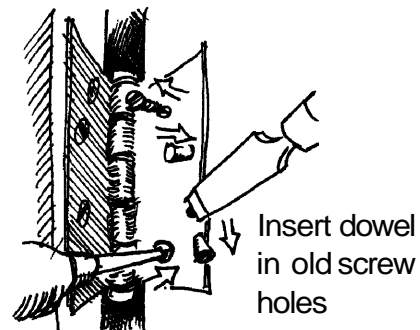

# DOING THE WORK

## Install New Screws

- Replace screws. Use longer screws if necessary. Using a screwdriver bit on a brace makes this easier. Then remove and replace remaining screws as necessary.

## Adjust Stop

- Face of door should only contact the stop on the latch side of door frame. It should not crush or rub head or hinge side stop.
- Where stop is nailed, remove and replace with new matching stop. Leave 1/8 inch space between hinge, head stop, and the face of the door.

## Check Clearance

- If putty knife can't fit in gap between door and jamb at all points, crushing of painted surfaces may be occurring.

## Adjust Depth of Hinge Leaf

- If door is crushing hinge side and there is more clearance than necessary on the latch side, install metal shims behind hinge leaves. Keep at least 1/8 inch clearance on leaf side and 1/8 inch clearance on latch side. If not enough clearance, see p. 39.
- If only a small increase is needed between leaves of hinge to create a gap between door edge and jamb, place a steel rod between hinge leaves near pin and close door to slightly bend apart leaves.

## Clean Up and Clear

- See Section 4, p. 47

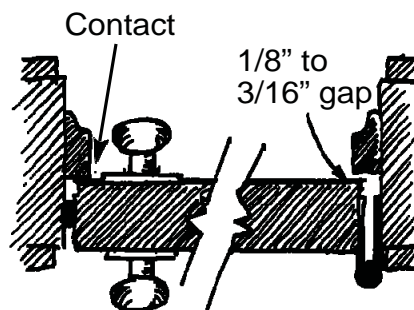

Check perimeter of door for clearance of 1/8" to 3/16"

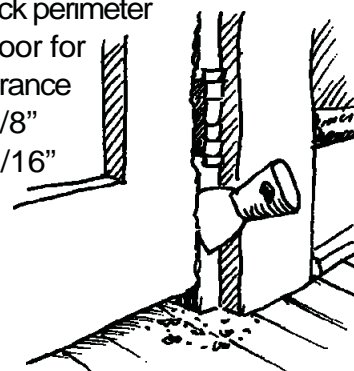

Crushing

Space

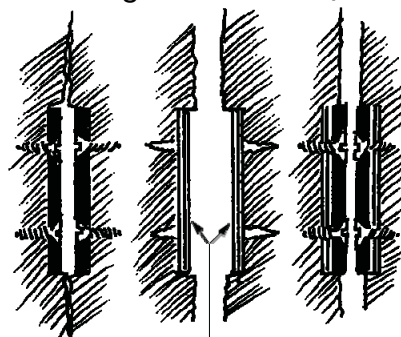

Add shim stock

Use steel rod (like screwdriver) to bend open hinge

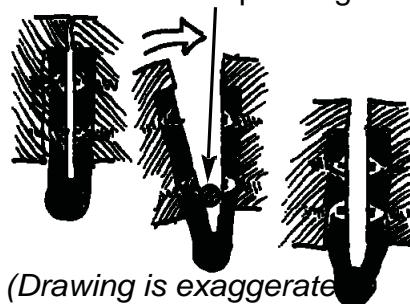

(Drawing is exaggerated)

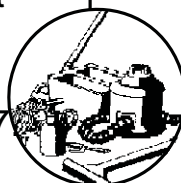

# DOOR RUBS OR STICKS

**PROBLEM** Door is scraping on latch side; or door is crushing jamb on latch side and there is not enough clearance on latch side to add shims to hinges. When paint on a door rubs or is crushed, paint chips can result.

**SOLUTION** Plane edges of door so that it operates smoothly and does not rub.

## Set Up

- See Section 2, p. 13.

## Remove Hinge Leaves

- Remove pins from hinges and hinge leaves from door.
- Set door on edge in a door hold. (See Section 5: Building a Door Hold, p. 74.)

## Hand Plane Edge

- Mist surface and hand plane a chamfer edge.
- Use a smooth bench or jointer plane (not a block plane) to remove the rest of the paint from the edge. Continue to mist while working. If a power planer is used to remove paint, it must be attached to a HEPA vacuum. Some power planers need an adaptor to accept HEPA attachments.
- Once paint is removed, use either a hand or power planer.

## Recut Gains

- Then, recut gains as necessary so hinge leaf is set about halfway into gain.

## Seal Edges

- Seal edges of door, particularly the bottom, and rehang.

## Clean Up and Clear

- See Section 4, p. 47.

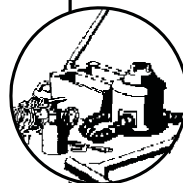
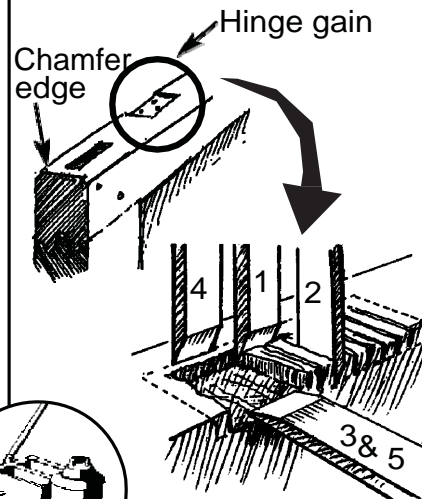
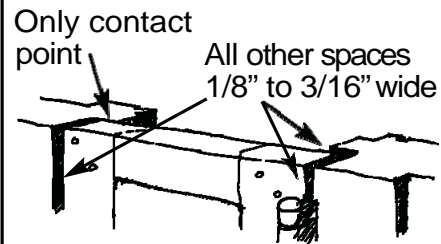
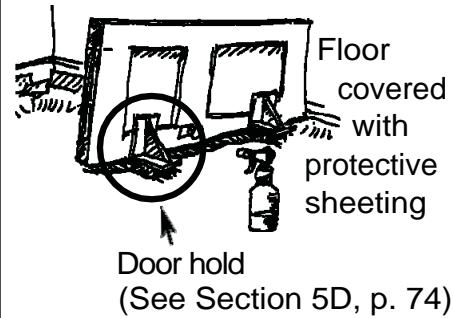



# CHIPPING PAINT ON STAIRS OR FLOOR

**PROBLEM** Painted staircase treads, risers or floors are worn, or the paint is chipping. Paint and other coatings used on staircases and floors in older homes often contain lead. Everyday friction and wear can produce paint chips and dust.

**SOLUTION** Cover portions of stairs or floor that are worn with durable material.

## Set Up

- See Section 2, p. 13.



## Stairs – Option #1: Install Tread Covers and Riser Enclosures

### Wet Scrape

- Mist and wet scrape any loose paint on treads and risers, particularly on edges.

### Prime and Paint

- Prime treads and risers. Paint edges that will not be covered by enclosures.

### Install Riser Enclosure

- Cut 1/4 inch lauan plywood to fit each riser. Sand exposed edges of lauan.

### Fasten

- Back caulk perimeter of riser with adhesive caulk. Press tight or nail with finish nails.

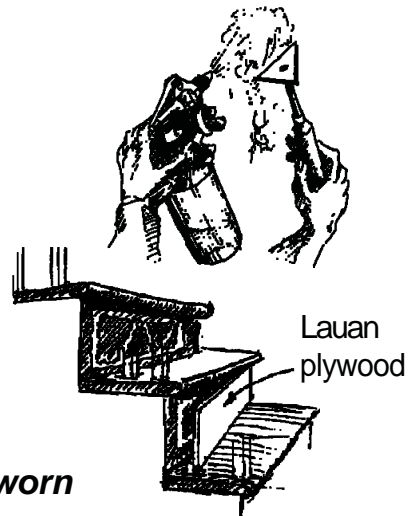
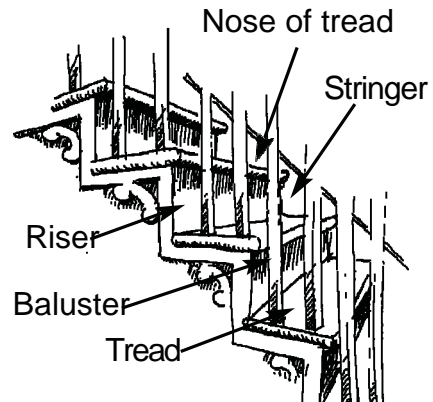

*If nose tread is not worn*

### Cut and Install Tread Cover

- Cut cover to fit over the tread and nose.
- Install cover with adhesive caulk or screws.

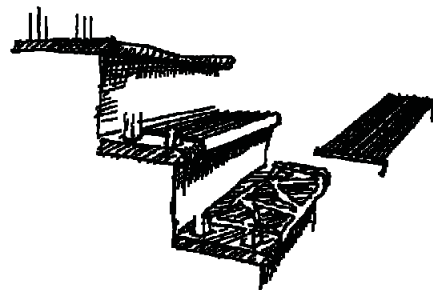

**If nose tread is worn**

**PROBLEM**

Installing a rubber tread over a worn tread nose creates a hollow space under the rubber tread cover. This can cause the rubber tread cover to tear, posing a tripping hazard.

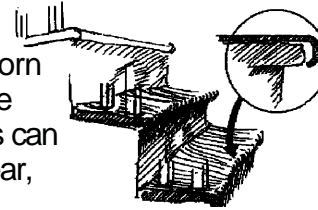

**Cut and Install Tread Cover**

- Cut tread cover to fit from the riser to rear edge of nose. Install with adhesive caulk or screws.

**Install Metal Nose Cover**

- Screw metal cover over edge of tread nose. It will span the worn area of the nose.

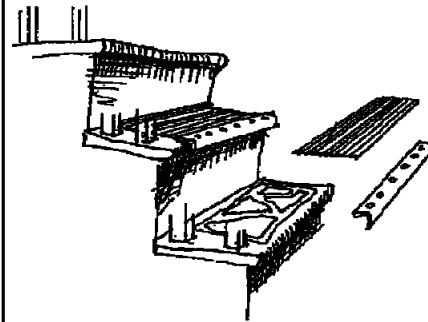

**Stairs – Option #2: Install Staircase Runner**

**Wet Scrape**

- Mist and wet scrape any loose paint on tread and riser, particularly on edges.

**Prime and Paint**

- Prime and paint treads and risers.

**Install Runner**

- Staple runner to top of top riser. Then fasten with staircase bars so runner may be easily removed for cleaning.

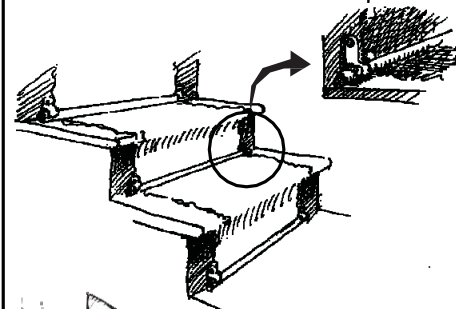

**Important:** Do not install runner or tread cover on landing of upper floor where its rear edge may become a tripping hazard.



**Floors**

**Prep Surface**

- If a floor needs to be refinished, use a floor sander attached to a HEPA vacuum.



**Caution:** High dust potential.

**Cover**

- Apply a coating to the floor to keep it smooth and cleanable.
- To maintain a smooth and cleanable surface, it is recommended that the use of wall-to-wall carpeting be avoided. Area rugs can be used instead.

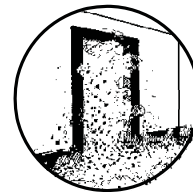

**Clean Up and Clear**

- See Section 4, p. 47.



# CHIPPED OR DAMAGED IMPACT SURFACES

**PROBLEM** Outside corners of walls, edges at passages, as well as trim, base cap, and shoe molding are being chipped due to impact from doors, furniture, and other objects. If these surfaces are covered with lead-based paint, the paint chips and the dust created may pose a health threat.

**SOLUTION** Protecting these surfaces with a durable material can prevent the creation of paint chips and dust.

## Set Up

- See Section 2, p. 13.

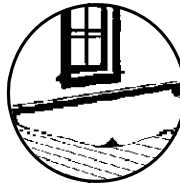

## Enclose Outside Corner

- Cover outside corners of walls with corner molding. Attach with nails and/or with a bead of adhesive.

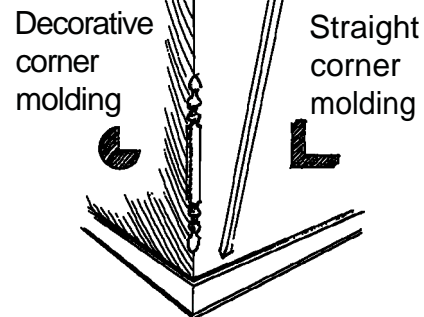

## Protect Base

- In places where a baseboard shows signs of impact, replace shoe and protect cap with lattice strip.
- When replacing shoe, bed new shoe in bead of caulk to seal out moisture and prevent infiltration of dust.

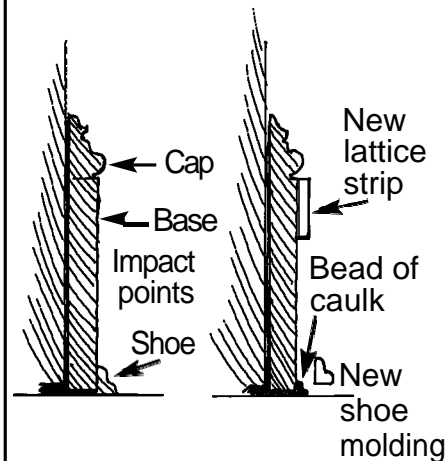

## Clean Up and Clear

- See Section 4, p.47.

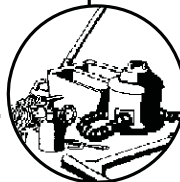



# H I G H D U S T J O B S

Some jobs create large amounts of dust. To be safe, workers doing this type of work should:

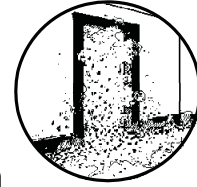

1. Wear half-mask respirators rated by NIOSH as N100 (or HEPA) at a minimum and be trained to wear and maintain them, or conduct air monitoring to show that they are not needed. (See Section 5D: Respiratory Protection, p. 69.)
2. Completely isolate the work space from occupied spaces and use containment to protect other workers. (See next page.)
3. Receive lead worker or supervisor training from an accredited trainer. In most states, accredited courses are available. To locate a course in your state, contact the Leadlisting at 1-888-Leadlist (1-888-532-3547) or [www.leadlisting.org](http://www.leadlisting.org).



**Remember:** All house dust is unhealthy to breathe. It may contain lead, mold, asbestos, gypsum, roach waste, dust mites, coal dust, fiberglass, etc.

## Examples of High Dust Jobs

The following types of work are likely to create high levels of dust:

**Demolition.** Demolition includes tearing off siding and/or demolishing old plaster walls or ceilings.

**Opening Up Wall Cavities.** These jobs include:

- Removing old paneling and baseboards
- Removing door casings and frames or window casings or jambs

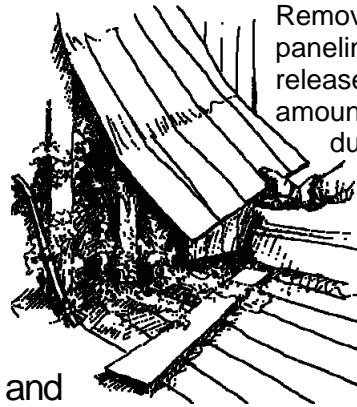

***“It’s not just what’s on the wall, it’s the dust behind it.”***

**Removing Old Drop Ceilings.** Lots of dust can accumulate above ceiling panels.

**Improperly Removing Wall-To-Wall Carpet.** A carpet that’s been on the floor for many years has gathered large amounts of household dust, which may include lead dust. Improperly removing it can release a large amount of dust.

**Paint Scraping.** Scraping large painted areas, such as the side of a house or an entire room, even when done correctly, can create a large amount of dust.

### Containing Dust

Use this system to keep dust from spreading to another room.

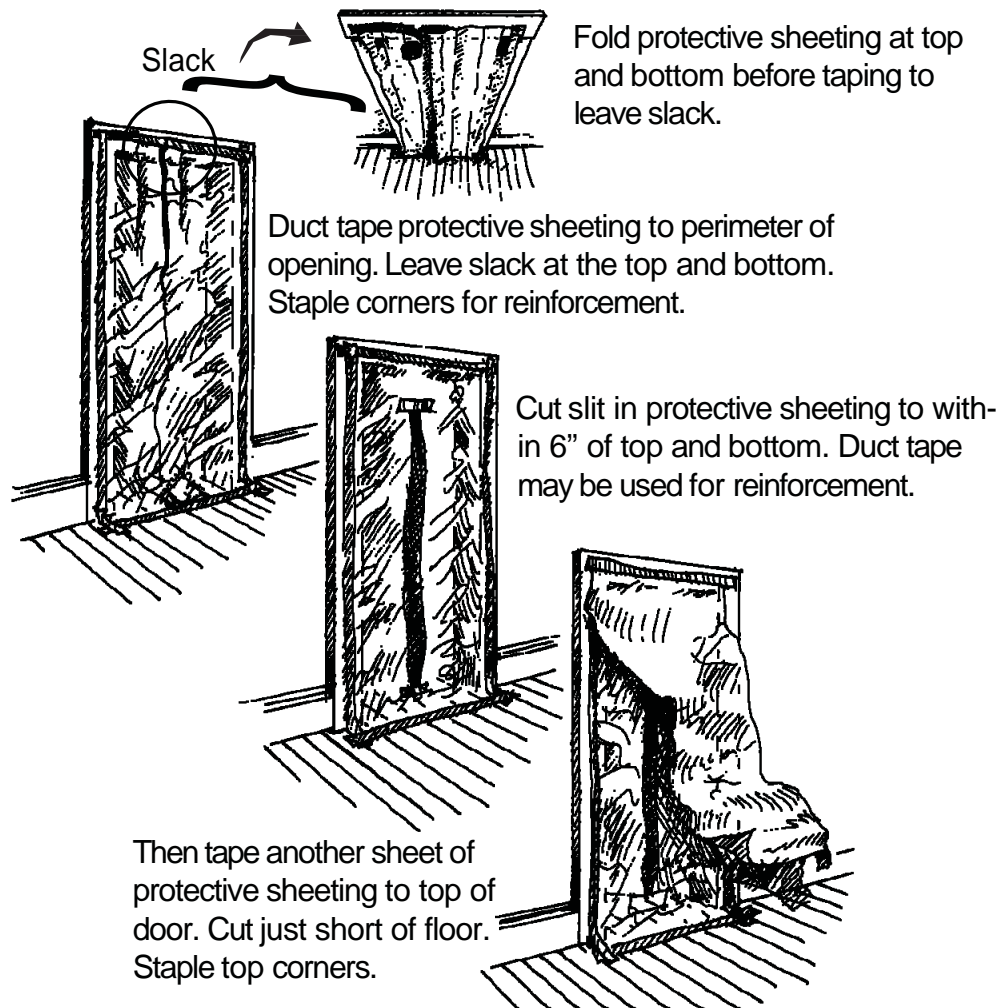

If a job creates extremely high amounts of dust (for example, demolition) or large amounts of dust in the air for more than short periods, the protective flap system shown above may not be sufficient to prevent dust from spreading beyond the work area.

For these types of jobs, a more protective system called "isolation" is needed so that dust does not spread beyond the work area. Isolation means that the work area is sealed with no direct access to occupied areas of the home. Workers need to use an entrance that is separate from occupants until cleanup is completed.

# C L E A N I N G U P

It is very important to use proper cleanup procedures at the end of the job. Dust and paint chips left behind at the end of the job may contain lead and may endanger children. Have dust wipe samples collected at the end of the job to be sure that it is safe for children to return.

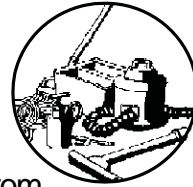

## Pick Up Work Area

- Pick up large chips with damp paper towel.

**AND/OR**

- Mist then push dust into dust pan.

Make dust pan from flashing and clean with a whisk broom.



## Pick Up Protective Sheeting

- Clean off protective sheeting. Fold dirty side inward (dirty side to dirty side). Dispose of protective sheeting at the end of each job. Protective sheeting may be used again within the same work area if it has not already been folded.

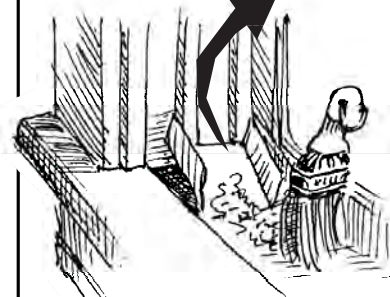

Mist and push dust

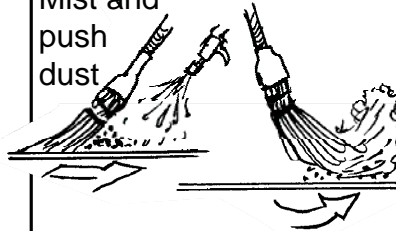

## Vacuum

- HEPA vacuum all horizontal surfaces—slowly.
- Vacuum all ledges, sills, stools, molding tops, dusty surfaces, etc.
- Vacuum floor under work area. Use corner tool in corners, cracks of trim, and between floor boards.
- Vacuum floor with floor brush and carpet with a carpet tool.

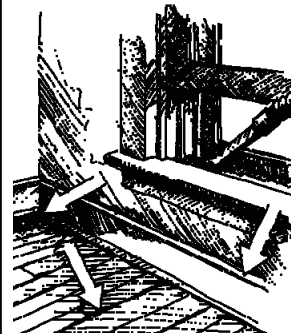

Vacuuming the cracks is very important.



## Mist and Scrub

**Important:** Vacuum carpet very slowly.

- Wet rag with detergent then wring out.
- Mist surface or rag as you clean.
- Lead needs scrubbing, not just wiping.

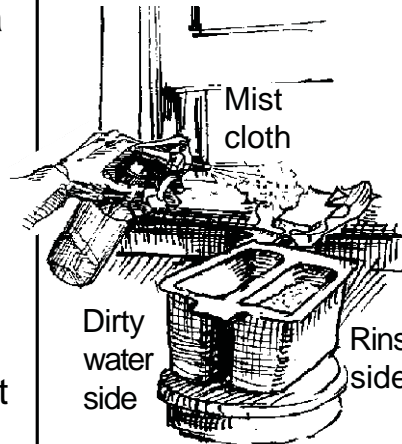

Mist cloth

Dirty water side

Rinse side

AT THE END OF THE JOB

**Rinse Rag**

- Squeeze rag into empty side of split bucket. Rinse out rag. Squeeze into empty side. Repeat as needed.
- Change rinse water often.
  - Use paper towels first if surfaces are very dirty.
  - Replace rag when it looks dirty.
- Clean until dust and debris are removed.

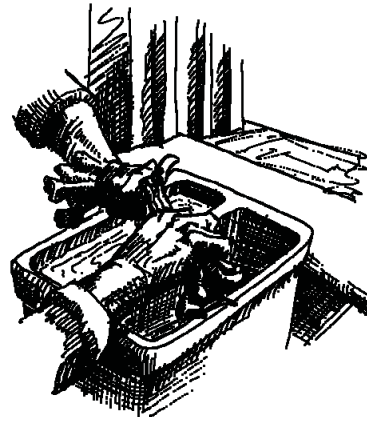
**Cleaning Floors****Mist and Scrub**

- At start of cleaning, soak mop in detergent water then mist small area with detergent before mopping.
- Scrub with mop.

**Squeeze Out and Wash**

- Squeeze mop into empty bucket then rinse in rinse water. Rinse often. Squeeze out and rinse again. Mop small areas at a time.

**Rinse**

- Repeat above process using clean water rather than detergent. When cleaning up a work site, use a new mop head for rinse stage.

*Recommendation: Make a final pass with a HEPA vacuum.*

**Dispose of Waste**

- See following section.

**Take Dust Wipe Sample**

- See Section 5D: Testing Dust for Lead, p. 71.

Double bucket

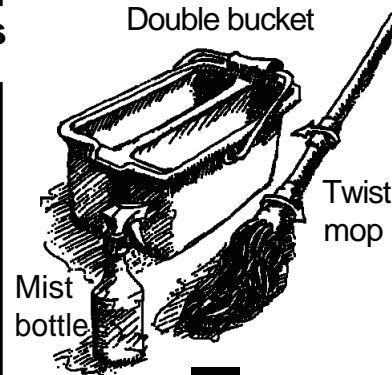
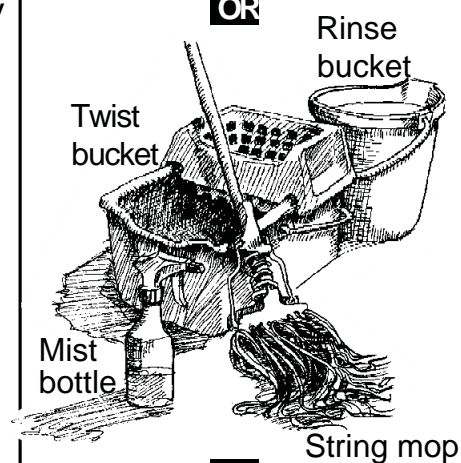
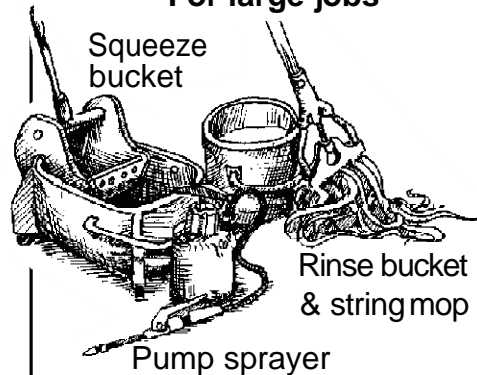
**OR****OR****For large jobs**

# D I S P O S A L O F W A S T E

After cleanup of the work area, take care to safely handle and remove dust and debris from the job. Supervisors should check with the EPA and their state's agency responsible for waste to find out about specific Federal, state, and local regulations regarding disposal of waste that may contain lead-based paint.

---

## Key Principle:

**Confine dust and waste to the work area that will be cleaned.**

### Disposal Practices

Specific guidelines are:

- Avoid carrying construction waste through an occupied space. If you must carry it through an occupied space, first place it in a heavy duty plastic bag or wrap it in protective sheeting and seal with tape.
- When a dumpster is used, keep the dumpster covered. If a chute is used, cover the chute (or use a barrel chute) and cover the dumpster.
- Store all waste in a secure container or dumpster until disposal. Do not transport waste in an open truck, unless it is bagged and sealed.

### Water

Water used for clean up should be dumped into a toilet. Never dump this water in a sink, tub, on the ground, or down a storm drain.

Water used to remove paint through pressure washing must be collected in drums and may need to be tested to determine if it is hazardous. Check with your state agency responsible for waste.



# C H E C K   Y O U R   W O R K !

## Check Quality of Work & Cleanup

Check work quality **during the job** and at the **end of the job**.

- **Was the cause of the problem corrected?**
- **Were proper work practices used?**
- **Was cleanup done thoroughly?**

## How to Check:

Checking your work involves two important steps.

### 1. Visual Checks

Use the checklist inside the back cover of this guide when performing visual checks.

- **During the Job.** Be sure that:
  - the cause of the problem is being corrected;
  - the work area is safely set up;
  - the practices in this guide are being used; and
  - dust and debris are not spreading beyond the work area.
- **End of the Job.** Be sure that the repairs were done properly and that no dust or paint chips remain.

### 2. Take a Dust Wipe Sample

When interior work disturbs painted surfaces or produces dust, have dust wipe samples taken at the end of the job to check for harmful levels of lead-contaminated dust.

To be accurate, these tests must be done according to specific procedures. See Section 5D, p. 71, for more information about these tests, and who should perform them.

**How to  
Check  
Cont'd**

Dust wipe testing is recommended at the end of any job that disturbs paint or produces dust. It is **strongly recommended** when:

- Work that disturbs paint is done in homes built before 1978.
- A young child or pregnant woman lives in the home.
- Performing unit turnover or regular maintenance in rental properties.

**Why Is It  
Important  
to Check  
Work?**

Checking that work was done properly is important because:

- Failing to correct conditions causing damage or deterioration results in repairs that do not last.
- Work that fails to follow the recommendations in this guide may spread dust and paint chips beyond the work area and may endanger children in the home.
- Dust and paint chips left behind due to poor cleaning may contain lead and may also endanger children in the home.
- For contractors, checking your work improves the quality of a job and is likely to reduce the risk of a lawsuit in the event a child in the home is later found to have high levels of lead in his/her blood.
- Leaving a clean job site is greatly appreciated by customers.

## ONGOING MONITORING & MAINTENANCE

### Regularly Check Repairs for Deterioration, Paint Chips, and Dust

Property owners should regularly monitor painted surfaces where maintenance or improvements were performed.

Check to see if:

- New evidence of deterioration or paint failure is present.
- The cause of the problem was corrected.
- Lead dust hazards are present. *Important: This can only be done by dust wipe sampling.*

### Maintain Surfaces and Thoroughly Clean

Then:

- Perform repairs, as needed, to maintain surfaces in a smooth and cleanable condition using the methods recommended in this guide; and
- Clean the area thoroughly using the practices described earlier in this section.

### Methods of Monitoring

Follow the same methods used to check your work:

- **Visual Check.** Look for deterioration, paint failure, dust and paint chips. Use the checklist inside the back cover of this guide.
- **Test for Lead Dust.** Have dust wipe samples taken to check for dust that may be contaminated with lead. A test is needed to determine when dust contains harmful amounts of lead.

To be accurate, these tests must be done according to specific procedures. See Section 5D, p. 71, for more information about these tests, and who should perform them.

### When to Monitor?

- **Annually.** Perform a visual check of past repairs and improvements involving painted surfaces.
- **During Unit Turnover or Routine Maintenance.** Perform a visual check of past repairs and improvements involving painted surfaces.
- **Every Two Years.** Get a dust wipe test done at least every two years. This type of test is **strongly recommended** when a young child or pregnant woman lives in the home.

**Why Is It  
Important to  
Monitor &  
Maintain  
Work?**

Monitoring and maintenance helps:

- Plan and implement maintenance tasks
- Protect occupants and neighbors, particularly children, from lead exposure
- Give owners, contractors, and residents a record of the condition of the unit

# A . G L O S S A R Y

**Aluminum flashing** - thin aluminum sheeting, also known as coil stock.

**Aviation snips** - metal cutters.

**Chamfer** - a small bevel on an edge.

**Enclosure**- a rigid, durable construction material that is mechanically fastened to the structure to cover painted surfaces.

**Fit testing** - a method to check if a respirator fits properly over the face.

**Gain** - notch chiseled in a door for a hinge leaf.

**HEPA filter** - High-Efficiency Particulate Air filter. A filter that can remove particles of 0.3 micrometers or larger from the air at 99.97 percent or greater efficiency.

**HEPA vacuum**- a vacuum with a HEPA filter.

**HUD Guidelines** - HUD's *Guidelines for the Evaluation and Control of Lead-Based Paint Hazards in Housing*

**Interim controls**- a set of measures to reduce exposure to lead hazards. Interim control measures include special cleaning, repairs, paint stabilization, enclosure, and containment. For a full discussion, see HUD's *Guidelines for the Evaluation and Control of Lead-Based Paint Hazards in Housing*

**Lauan plywood**- 1/4 inch plywood made of lauan with a smooth face.

**N100** - a NIOSH filter class that describes a respirator's ability to filter airborne particles. A respirator filter rated as N100 removes particles of 0.3 microns or larger from the air at 99.97 percent or greater efficiency.

**NIOSH** - National Institute for Occupational Safety and Health, an agency within the Centers for Disease Control and Prevention that tests and certifies safety equipment including respirators.

**OSHA** - Occupational Safety and Health Administration, an agency of the U.S. Department of Labor that oversees worker safety.

**Paint stabilization** - a process of wet scraping, priming, and finish coating of a deteriorated painted surface to prevent further deterioration.

**Permissible Exposure Limit (PEL)**- a dust exposure threshold set by OSHA. Work that creates lead dust levels in the air greater than the PEL must meet OSHA lead safety requirements for workers. OSHA has set the PEL for airborne lead dust at 50 micrograms per cubic meter ( $\mu\text{g}/\text{m}^3$ ) as a time weighted average. See Section 5D, p. 69, for technical information about OSHA requirements and Section 5B, p. 61, for information about OSHA regulations.

**Pilot hole** - a small hole drilled to guide the drilling of a larger hole.

**Protective sheeting**- made of plastic, poly or other material. Protective sheeting must be puncture and tear resistant, impermeable to liquids, durable, flexible, and lightweight.

**R-value** - a measure of heat containment; used for rating insulation effectiveness.

**Shim** - small piece of wood or metal used to fill space between two fastened components.

**Shroud**- a protective covering that contains dust and chips.

**Substrate**- a solid surface such as plaster, drywall, wood, etc.

**Tack pad** - a sticky pad that helps remove dust from shoes.

**Window trough**- the area of the sill between a window stool or interior sill and the frame of the storm window where the bottom sash rests when closed (also called a window well or exterior sill).

## B. F O R M O R E I N F O R M A T I O N

This section lists useful documents, web sites, and other lead-based paint information resources. Additional sources also exist. Use the reference letter on the right to locate the contact for each information resource.

Contacts are listed by letter on pages 62-64. Publications marked with an \* are for sale; others are available for free.

### ***Where can I get more information on...***

#### **Work practices and lead-safety?**

<b>Publications</b>	<b>Reference Letter</b>
<ul style="list-style-type: none"><li>• <i>Guidelines for the Evaluation and Control of Lead-Based Paint Hazards in Housing (July 1995).</i>* Technical guidance on methods for identifying and controlling lead-based paint and lead-based paint hazards. The <i>Guidelines</i> can also be downloaded for free from the HUD Office of Lead Hazard Control web site. (About 750 pages)</li></ul>	<b>B, C</b>
<ul style="list-style-type: none"><li>• <i>Residential Lead Desktop Reference (2nd Edition, June 1998).</i>* A CD-ROM containing a large variety of lead-based paint information resources.</li></ul>	<b>C</b>
<ul style="list-style-type: none"><li>• <i>Maintaining a Lead Safe Home (1997).</i>* A do-it-yourself manual for homeowners and property managers. (89 pages)</li></ul>	<b>B</b>
<ul style="list-style-type: none"><li>• <i>Lead-Based Paint: Operations and Maintenance Work Practices Manual for Homes and Buildings (May 1995).</i>* Technical guidance on safe work practices. (200 pages)</li></ul>	<b>G</b>
<ul style="list-style-type: none"><li>• <i>Guide Specifications for Reducing Lead-Based Paint Hazards (May 1995).</i>* Technical guidance on purchasing lead-hazard control reduction services and developing lead-hazard reduction work specifications. (About 500 pages)</li></ul>	<b>G</b>
<ul style="list-style-type: none"><li>• <i>Lead Safety for Nonprofit Property Owners, Developers, and Managers (July 1998).</i> Practical guide to developing policies and activities that incorporate lead safety in property management. (About 30 pages)</li></ul>	<b>F</b>

**Reference  
Letter**
**Publications**

- *Guide to Working Safely with Residential Lead Paint (1999)*. Pamphlet with key lead safety precautions to follow during repainting and home improvement.
- *Reducing Lead Hazards When Remodeling Your Home (September 1997)*. Pamphlet providing basic information about lead-based paint risks and precautions when remodeling pre-1978 homes.

**F**
**B, I, K**
**Web Sites**

- HUD, Office of Lead Hazard Control. Provides information on HUD regulations, technical and educational documents, and links to other lead resources.
- EPA, Office of Pollution Prevention and Toxics. Provides information on EPA regulations, technical and educational documents, and links to other lead resources.

**B**
**K**
**Worker protection methods?**
**Publications**

- *Protecting Workers and Their Communities from Lead Hazards: A Guide for Protective Work Practices and Effective Worker Training (1993)*.<sup>\*</sup> Guidance on worker protection methods, training workers, and complying with OSHA regulations. (About 500 pages)
- *Lead Exposure in the Construction Industry (1993)*. Fact sheets that describe worker protection measures needed to meet OSHA requirements for lead including respiratory protection and protective clothing. (Series of 6 fact sheets)

**L**
**J**
**Web Site**

- OSHA, Occupational Safety and Health Administration. Provides information on OSHA regulations, technical and educational documents, and links to other lead resources.

**J**

## Preventing children's exposure to lead hazards?

### Publications

- *Protect Your Family From Lead In Your Home (May 1995)*. Pamphlet that provides basic information about addressing and preventing lead-based paint hazards in the home.
- *Lead Poisoning Prevention: Directory of State Contacts (1997-98)*.\* Booklet that contains profiles of state programs to reduce lead hazards. (150 pages)
- *Directory of State and Local Lead Poisoning Prevention Advocacy Organizations (1998)*.\* List of state and local non-profit organizations that are working to prevent lead poisoning. (About 300 pages)

### Web Site

- Alliance to End Childhood Lead Poisoning. Information on lead poisoning prevention, lead issues, and program design. Site has publications that can be copied from the web.

## Public education and outreach materials?

### Web Site and Hotline

- National Lead Information Center. Information about lead hazards and poisoning prevention.

## Locating certified abatement contractors and clearance inspectors?

### Web Site and Hotline

- Leadlisting. List of qualified lead professionals including inspectors, risk assessors, abatement contractors, and analysis laboratories.

### Reference Letter

B, I, K

E

A

A

I

D

## Disclosure requirements?

### Publications

- *Protect Your Family From Lead in Your Home (May 1995)*. Pamphlet that provides basic information about addressing and preventing lead-based paint hazards in the home.
- *Disclosure of Lead-Based Paint Hazards in Housing (March 1996)*. Fact sheet that provides information on how to meet Federal disclosure requirements.
- *Questions and Answers on the HUD/EPA Disclosure Rule*. Answers to commonly asked questions about Federal disclosure requirements. (5 pages)
- *Interpretive Guidance for the Real Estate Community on the Requirements for Disclosure of Information Concerning Lead-Based Paint in Housing, Parts I and II (1996)*. In-depth guidance on the disclosure requirements for real-estate professionals. (27 pages)
- *Resource Handbook on Lead Hazard Disclosure for Homes and Apartments (1996)*.\* Comprehensive reference book on disclosure procedures including advice for renters and owners, a glossary of key terms, and copies of disclosure documents. (Approximately 300 pages)

### Reference Letter

B, I, K

K

K

K

A

## Respirators?

### Web Sites

- National Institute of Occupational Safety and Health. Provides information on the proper use of respiratory protection and various types of NIOSH-approved respirators that are available.
- Occupational Safety and Health Administration. Provides information on OSHA regulations regarding the use of respiratory protection.

H

J

## ***Where can I find...***

### **HUD's lead regulations?**

- 24 Code of Federal Regulations (CFR) 35 (Lead Rule). Contains lead hazard evaluation and reduction requirements for properties that receive HUD funding.

### **OSHA's lead regulations?**

- 29 CFR 1926.62 (Lead in Construction) and 29 CFR 1910.1025 (Lead in General Industry). These regulations cover Federal worker protection requirements for workers in industry, construction, remodeling, and renovation.

### **EPA's lead regulations?**

- 40 CFR 745 (Lead-Based Paint Poisoning Prevention in Certain Residential Structures). Contains the Federal regulations for the disposal of lead waste and contractor notification requirements.
- 40 CFR 745.80 (Residential Property Renovation). Federal rule requiring contractors to provide notification before the start of any work that disturbs a painted surface in pre-1978 homes.

### **Disclosure regulations?**

- 24 CFR 35 (HUD) and 40 CFR 745 (EPA). Regulations for disclosure of known lead-based paint and lead-based paint hazards by home sellers and landlords. This rule was published jointly by HUD and EPA.

## **Reference Letter**

**B**

**J**

**K**

**K**

**B, K**

**State lead laws?**

<b>Publication</b>	<b>Reference Letter</b>
<ul style="list-style-type: none"> <li>• <i>Summary of Lead Poisoning Prevention Statutes (February 1999)</i>. A state-by-state listing of local lead-related regulations, such as waste disposal requirements. Available by fax. (24 pages)</li> </ul>	<b>E</b>

**Contacts**

<b>Reference Letter</b>	<b>Organization</b>	<b>Types of Resources</b>
<b>A</b>	Alliance to End Childhood Lead Poisoning 227 Massachusetts Avenue, NE, Suite 200 Washington, DC 20002 202-543-1147 <a href="http://www.aeclp.org">http://www.aeclp.org</a>	Publications
<b>B</b>	Office of Healthy Homes and Lead Hazard Control; U.S. Dept. of Housing and Urban Development (HUD) 451 Seventh Street, SW, Room P-3206 Washington, DC 20410 202-755-1785 <a href="http://www.hud.gov/offices/lead">http://www.hud.gov/offices/lead</a>	Publications Program development
<b>C</b>	HUD USER P.O. Box 6091 Rockville, MD 20849 1-800-245-2691 <a href="http://www.huduser.org">http://www.huduser.org</a>	Publications
<b>D</b>	Leadlisting 1-888-Leadlist (1-888-532-3547) <a href="http://www.leadlisting.org">http://www.leadlisting.org</a>	Technical consultation
<b>E</b>	National Conference of State Legislatures 1560 Broadway, Suite 700 Denver, CO 80202 303-830-2200 <a href="http://www.ncsl.org">http://www.ncsl.org</a>	Publications

Reference Letter	Organization	Types of Resources
F	National Center for Lead Safe Housing 10227 Wincopin Circle, Suite 205 Columbia, MD 21044 410-992-0712 <a href="http://www.leadshousing.org">http://www.leadshousing.org</a>	Publications Technical consultation
G	National Institute of Building Sciences (NIBS) Publications Department 1201 L Street, NW, Suite 400 Washington, DC 20005-4014 202-289-7800 <a href="http://www.nibs.org">http://www.nibs.org</a>	Publications Training
H	National Institute of Occupational Safety and Health (NIOSH) Hubert H. Humphrey Building, Room 7154 200 Independence Avenue, SW Washington, DC 20201 800-35-NIOSH (800-356-4674) <a href="http://www.cdc.gov/niosh/home-page.html">http://www.cdc.gov/niosh/home-page.html</a>	Publications
I	National Lead Information Center (NLIC) 8601 Georgia Avenue, Suite 503 Silver Spring, MD 20910 Information Clearinghouse: 1-800-424-Lead (1-800-424-5323) <a href="http://www.epa.gov/lead/nlic.htm">http://www.epa.gov/lead/nlic.htm</a>	Publications Training

Reference Letter	Organization	Types of Resources
<b>J</b>	Occupational Safety and Health Administration (OSHA) U.S. Department of Labor, OSHA Publications Office 200 Constitution Avenue, NW, Room N3101 Washington, DC 20210  <i>OSHA Lead web page:</i> <a href="http://www.osha-slc.gov/SLTC/lead/index.html">http://www.osha-slc.gov/SLTC/lead/index.html</a>  <i>OSHA Respirator web page:</i> <a href="http://www.osha-slc.gov/SLTC/respiratory_advisor/mainpage.html">http://www.osha-slc.gov/SLTC/respiratory_advisor/mainpage.html</a>	Technical consultation Enforcement
<b>K</b>	Office of Pollution Prevention and Toxics (OPPT) U.S. Environmental Protection Agency (EPA) 401 M Street, SW (7401) Washington, DC 20460 202-260-3810 <a href="http://www.epa.gov/lead">http://www.epa.gov/lead</a>	Publications Program development
<b>L</b>	Society for Occupational & Environmental Health 6728 Old McLean Village Drive McLean, VA 22101 703-556-9222 <a href="http://www.soeh.org">http://www.soeh.org</a>	Publications

## C. GETTING THE WORD OUT

### How Owners and Occupants Can Work Together to Improve Lead Safety In Homes

Gaining tenant cooperation can help rental property owners and managers respond promptly to conditions that could pose a health threat to occupants.

#### *Owner Responsibilities*

1. Check the building to be sure that:

- The building shell is sound.
- Water isn't coming in from the outside and causing damage.
- Sources of moisture inside are not causing damage.
- Painted surfaces are intact.
- Doors and windows work properly.
- All surfaces are clean and cleanable.

2. Maintain the building.

- Train maintenance staff to minimize dust, clean up effectively, and protect themselves.
- Conduct regular building checks for potential problems, such as:
  - Flaking or peeling paint
  - Water damage to paint, plaster, or wood
  - Plumbing or roof leaks
  - Painted doors and windows that do not operate smoothly

3. Educate occupants and gain their cooperation.

- Fulfill Federal notice and disclosure requirements.
- Have occupants inform you of damaged paint and other maintenance problems.

#### **When Maintenance or Renovation Work is Done**

Give occupants the Lead Safety pamphlet required by Federal regulations (see page 66).

Tell occupants:

- ✓ Why repairs are necessary.
- ✓ The work schedule.
- ✓ How they and their possessions will be protected.
- ✓ Why they may need to leave during the work.

- ❑ Explain to occupants why steps, such as regular cleaning, prevent lead-based paint hazards. (See below.)
- ❑ Consider providing cleaning supplies and tools (see page 75) to occupants to encourage cleaning.
- ❑ Remind tenants that it is a good practice to provide notice of problems in writing.
- ❑ Make sure occupants understand the property's maintenance reporting procedures and indicate that these problems require priority attention.

### ***Precautions Tenants Can Take to Protect Their Family***

Occupants should pay special attention to page 7 of the pamphlet *Protect Your Family From Lead In Your Home*. It describes steps that occupants can take to reduce the chance that they will be exposed to lead hazards. Suggestions from this pamphlet include:

- ❑ Clean floors, window frames, interior window sills, and other flat surfaces each week using warm water and an all-purpose cleaner.
- ❑ Clean up any paint chips immediately.
- ❑ Keep child play areas clean.
- ❑ Wash children's hands often.
- ❑ Keep children from chewing interior window sills and other painted surfaces.

### **Federal Notice and Disclosure Requirements**

(24 CFR Part 35 or  
40 CFR Part 745)

- ✓ Landlords and home sellers must notify future occupants about lead-based paint hazards by giving them the pamphlet *Protect Your Family From Lead in Your Home*.
- ✓ Landlords and home sellers must disclose information about known lead-based paint and/or lead-based paint hazards before dwelling leases or home sales contracts take effect. Leases and sales contracts must also include a form about lead-based paint that meets Federal requirements. Contact HUD or EPA for more information about these requirements (see Section 5B, p. 57).

## Notice Prior to Renovation

Federal law requires contractors and owners of rental properties to inform occupants about the risks of lead-based paint before non-emergency repair, maintenance, and home renovation work begins. This law applies for all work on surfaces greater than 2 square feet per component. Contractors and property owners must distribute copies of the pamphlet *Protect Your Family From Lead In Your Home* before any work starts. See EPA's regulation at 40 CFR 745.80. Also see Section 5B, p. 57, for sources that can provide copies of this pamphlet.

Contractors and owners must make sure that occupants have received the pamphlet.

- For owner-occupied homes, the contractor must have the homeowner sign an acknowledgement form after receiving the pamphlet. Or, the contractor can send the pamphlet by certified mail.
- For tenants, the contractor or property owner must have an adult occupant sign an acknowledgement form after receiving the pamphlet. Or, the contractor or owner can send the pamphlet by certified mail. If the contractor cannot get a signed acknowledgement, the contractor must sign a statement documenting this.
- For work in common areas, such as the lobby, of an apartment building, the contractor must give the pamphlet to the owner and to the occupants of all affected areas and inform them of the nature, location, timing, and length of the job.

---

### Why Lead Safety Makes Sense for Property Owners and Contractors

Property owners and contractors that use safe work practices benefit in several ways.

#### Advantages for Owners of Residential Rental Properties

Owners who maintain their rental properties using work practices that increase lead safety can use this information to attract tenants who are concerned for their child's health. Some local agencies may even maintain a listing of housing units that meet certain lead-safety standards. When giving prospective tenants the lead-based paint pamphlet and the required disclosure information, they can tell the tenant that the property has a program to minimize the risk of hazards from lead-based paint. A safety program would include:

- Educating and training maintenance workers.
- Examining property at turnover and then every year for deteriorating paint.
- Correcting conditions that may cause paint to flake and peel (excessive moisture, binding doors, etc.).
- Doing work safely and cleaning up well.
- Making sure surfaces are cleanable and doing a professional cleaning at turnover.
- Performing dust wipe tests before occupancy, and after every maintenance job that disturbs old paint. It is also recommended to perform a dust wipe sample test at least every two years. Keep the results on file.
- Encouraging tenants to inform property owners if there is a problem.

### **Advantages for Contractors**

Doing work safely can enhance a contractor's reputation, maintain the safety of workers, and protect the health of customers and their children.

A program for lead safety can also help contractors when bidding new jobs. For example, contractors performing repairs and improvements in homes built before 1978 must give potential customers a pamphlet about the risk of lead-based paint during renovation.

Contractors that follow practices for lead safety can demonstrate to customers that they understand the risks and show that their workers take specific precautions to protect against lead-based paint hazards. Lead-safety can help “give you a leg up” on the competition.

Safe work practices also offer benefits that are important to customers:

- Dust and debris are confined to the work area.
- A “clean” work area at the end of the job.
- Some work offers additional benefits. *(For example, repairs to windows can improve their operation, prevent damage from moisture, and lower energy and maintenance costs.)*
- Lead safety also helps protect you as a contractor. For example, having an independent, certified professional take dust wipe samples of the work area promptly after cleanup provides strong documentation that no lead hazards were present in the work area at the end of the job.

## D. MORE ABOUT TECHNICAL TOPICS

### Respiratory Protection

Respiratory protection helps prevent workers from breathing harmful amounts of lead and other substances, touching their mouths with dusty hands, or swallowing paint chips.

When work creates high levels of dust in the air, properly trained and certified lead-based paint professionals should do these high dust jobs. If you work for someone, and plan on doing this type of work, your employer must meet the requirements of the OSHA Lead in Construction Standard (29 CFR 1926.62). These requirements include respiratory protection when work creates lead dust in air that exceeds the “permissible exposure limit” (PEL) — see Air Monitoring and Results sections below. See Section 5B, p. 57, for sources of information about OSHA requirements.

Respirators may be required for activities that generate high levels of dust such as:

- Demolishing painted surfaces
- Opening up wall and ceiling cavities
- Using power tools on painted surfaces
- Dry scraping large painted areas

For this type of work, OSHA requirements include the following:

- Training workers on how to properly use and maintain respirators.
- Making sure proper respirators are always available and that workers have been fit tested. Where respirator use is required, workers must be part of a written respiratory protection program that meets OSHA standards (29 CFR 1910.134).

Many types of respirators can be used:

- Disposable respirators can be used if they are rated by NIOSH as N100 (or HEPA) — this information can be found on the respirator’s package or the respirator itself.



Dust mask not NIOSH approved

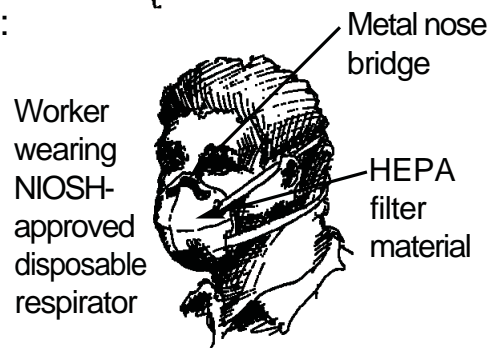

Worker wearing NIOSH-approved disposable respirator

## RESOURCES

- Non-disposable respirators, also rated by NIOSH as N100, often have replaceable cartridges and require regular maintenance.
- 

Worker wearing a non-disposable respirator
- Having a trained person do air monitoring that measures the amount of dust in the air to determine if respirators are required by OSHA, and the appropriate level of protection. Workers must wear proper respirators while air monitoring is being done.

### **Air Monitoring**

Air monitoring is done to ensure that workers are not being exposed to dangerous levels of lead dust in the air, and to comply with OSHA requirements. It must be done by a person with special training. A worker being monitored wears a small plastic canister clipped to his/her clothing near the face. A pump in a device clipped to the belt draws air and dust into the canister. The canister is then sent to a lab to measure how much lead dust was in the air.

### **What Do the Results Mean?**

The results are measured in micrograms per cubic meter ( $\mu\text{g}/\text{m}^3$ ). If the amount of lead dust in the air exceeds the permissible exposure limit (PEL) of  $50 \mu\text{g}/\text{m}^3$ , workers must wear at least a half-face respirator with an N100 (or HEPA) rating and certain OSHA requirements must be followed.

Results may show that respirators are not necessary or that a greater level of protection is needed. If the results show lead dust levels in the air above  $500 \mu\text{g}/\text{m}^3$ , a more protective respirator is required.

### **Other Protection**

In addition to respiratory protection for activities that generate high levels of dust, compliance with OSHA's Lead in Construction Standard may involve blood tests for workers, medical monitoring, hand washing facilities, other personal protective equipment, shower and changing areas, and additional training.

---

## Testing Dust for Lead

By having dust wipe samples taken, job supervisors and property owners can locate dust lead hazards and test the effectiveness of cleaning at the end of a job.

### Where Are Dust Samples Taken?

Samples are taken in the area of the dwelling where work has been completed. The following surfaces within the work area should be sampled:

- Floor
- Interior window sills (*also referred to as window stools*)
- Window troughs

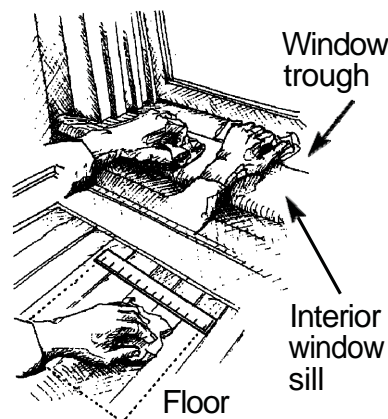

### When Should Dust Samples Be Taken?

- At the end of a job
- If there is a child or pregnant woman living in the home
- Before a family moves into a home

### What Do the Results Mean?

The results of the laboratory analysis will show the amount of lead found in the dust from the area sampled. The results are measured in micrograms per square foot ( $\mu\text{g}/\text{ft}^2$ ).

To determine if a lead-based paint hazard exists, based on EPA's requirements, compare the results to the following standards:

- 40  $\mu\text{g}/\text{ft}^2$  on the floor
- 250  $\mu\text{g}/\text{ft}^2$  on the interior window sill (stool)

If the results for a sample are higher than these standards, a dust lead hazard is present. For clearance purposes only, a value of 400  $\mu\text{g}/\text{ft}^2$  should be used for window troughs.

## Who Can Take Dust Wipe Samples?

Following painting, home maintenance, and renovation work:

- In homes receiving Federal assistance, dust wipe samples, if required by regulations, must be taken by appropriately trained personnel who were not involved in the work. This “clearance” testing may be done by a lead-based paint inspector, risk assessor, or sampling technician certified by a State or the EPA. Clearance testing may also be done by a person trained as a sampling technician, as long as a certified lead-based paint inspector or risk assessor approves the technician’s work and signs the clearance examination report.
- For all other homes, it is recommended that dust wipe samples be taken by a trained sampling technician, or, preferably, a certified lead-based paint inspector, risk assessor, or sampling technician. Some states require that dust wipe samples be taken by a certified person.

## What Actions Do I Take Based On the Results?

If the results show dust lead levels higher than the standards listed above, the area where the work was performed should be cleaned to remove the dust lead hazard.

If the dust wipe samples were taken as part of ongoing monitoring by maintenance staff or the property owner, the surfaces where work was performed should be examined to see if the work has failed or new conditions that generate dust have developed. In either case, these conditions should be corrected using lead-safety principles and work practices.

If the work required to correct the likely source of the dust lead hazard is beyond the scope of this guide, the property owner should seek the help of a lead-based paint professional trained to safely correct lead-based paint hazards.

---

## Setting Up a Dust Room

A dust room can be useful for dusty work on building components that can be moved. For example, scraping or planing doors or window sashes can be done in a dust room. A dust room is particularly useful when working in occupied spaces.

The dust room can be any room that can be closed off. The door can be covered with a flap system (see page 46) and the floor can be covered with protective sheeting taped to the baseboard.

Workers in this room should wear disposable clothing and wear respiratory protection. Wall and ceiling vents inside the room should be sealed off.

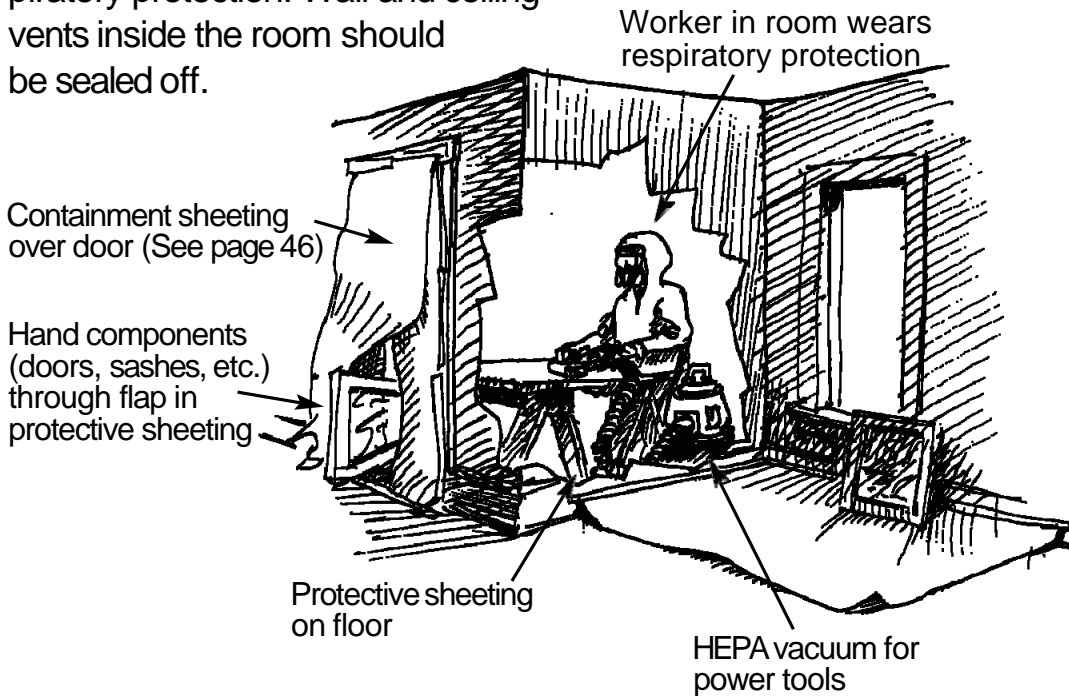

## Building a Door Hold

A door hold makes working on doors easier and safer.

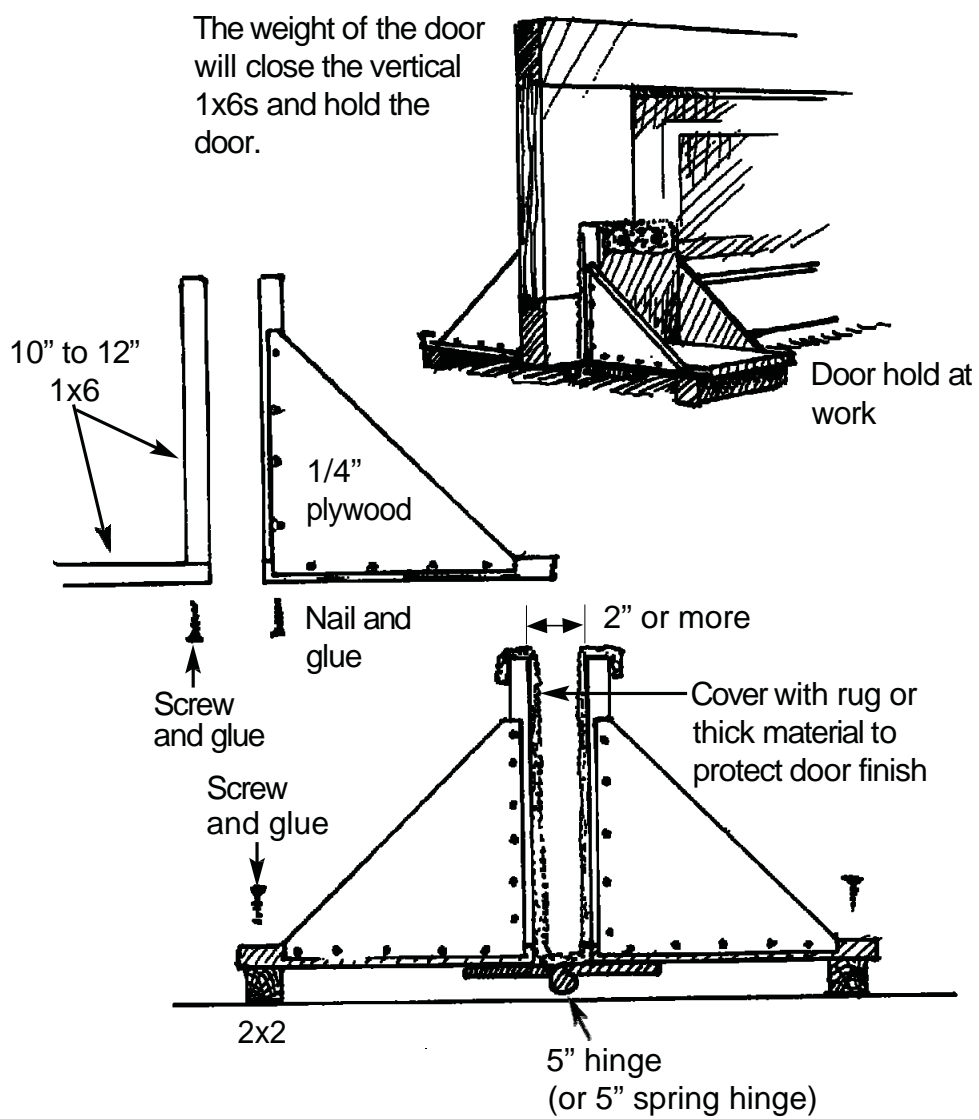

## E . T O O L   A N D   S U P P L Y   L I S T

### Additional Tools Needed for Lead-Safety Work

(Not every tool is needed for every job.)

**Paint scrapers** - A variety of scrapers are useful; carbon blades last longest. A mill file works well to keep scraper blades sharp.

**Sanding sponges and wet/dry sandpaper**- Where areas need to be smoothed or feathered, these abrasive tools, when used wet, keep dust to a minimum.

**Mist bottles** - Misting a surface being scraped or cut keeps down dust. Squeeze bottles work best in small areas. For larger jobs, a pump pressure sprayer in a knapsack works best.

**Plane** - A jack, smooth, or jointer (not block) plane. Hand planes are good for removing paint from edges such as the edge of a window, stool, or door. They create very little dust.

**Cleanup station**- A kitchen counter with a working sink is a good place for a cleanup station. If not available, set up a board with 3 buckets and a pump sprayer.

The station should have:

- Paper towels and soap
- Pads for cleaning respirators
- A 2-bottle eye-wash station
- A first aid kit
- Clipboard with emergency numbers
- Drinking water and cups

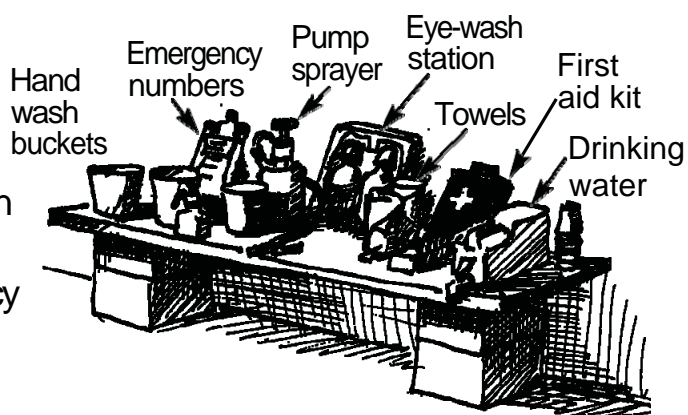

### Personal Protective Clothing and Equipment

- A disposable respirator rated by NIOSH as N100 (or HEPA)
- A half-face, air cartridge respirator rated by NIOSH as N100 (or HEPA)
- Protective, lightweight, disposable suits with elastic sleeves and ankles
- Shoe covers (slip resistant is recommended)
- Safety glasses (vented goggles if working in high dust conditions or when using liquids or strippers)
- Ear protection if using power tools

## **Cleaning Equipment**

- Bottle mister and pump sprayer for detergent
- Mops and buckets
- Tack cloths for wiping furnishings that may be damaged by water
- Heavy-duty paper towels and/or rags

**Vacuums-** At the end of a job, use a HEPA vacuum because it will capture even the finest dust. For regular household cleaning, use a HEPA vacuum if available. If one is not available, use a fine filter in your vacuum known as micron or allergen bags.

## **Painting Supplies**

- Use commercial grade cleaners; there are also lead-specific cleaners. (Note: Trisodium phosphate [TSP] is banned in some states.)
- Degreasers may be necessary on some walls.
- Use deglosser or wet sanding supplies.
- Where wood is exposed, use a sealer and then apply a best grade primer or primer-sealer.

## **Other Tools**

- Coil stock for covering window troughs. Coil stock is available with white and brown sides to match window trim color (see page 36).
- Window opening tool for windows that are painted shut (see page 29).
- Brace with screwdriver tips for removing and replacing hinge screws.
- Power planer with exhaust port that can be attached to HEPA vacuum. A power planer can be used for stripping window sashes and doors in a contained work area with respiratory protection.









# G . W O R K C H E C K L I S T

## Before Work Begins

- Are the possible risks to occupants identified?
- Are the occupants informed of the possible risks and their responsibilities?
- Are the causes of the problems located?
- Is the work area set up?
- Is the work area closed off from occupants?

## During Work

- Are dust and debris being contained in the work area?
- Are workers wearing necessary protective clothing and equipment?
- Are workers cleaning up each time they leave the work site?

## At the End of the Job

- Did workers fix the cause of the problem?
- Did workers remove visible dust and debris?
- Did workers properly dispose of dust and debris?
- Did workers wet wash the surfaces?
- Were dust samples taken to make sure that cleanup worked?

## For Long-Term Maintenance

Is there a plan to:

- Maintain painted surfaces?
- Keep surfaces clean and cleanable?
- Prevent water and moisture damage?

---

This Guide may be reproduced and distributed without prior permission from the U.S. Department of Housing and Urban Development or any other Federal Agency.

**Disclaimer:** The guidance offered in this document is based upon the latest lead hazard control knowledge and technology available at the time it was written. Users bear all risks associated with reliance on these work practices and have sole responsibility for evaluating the information it contains. Users bear sole responsibility to form their own independent judgments on the document's use, modification, and adaptation as appropriate. Neither the United States Government nor any of its employees makes any warranty, expressed or implied, or assumes any legal liability for any use of, or the results of, any information, product, or process discussed in this document.

# Why Follow this Guide?



## The Simple Work Practice Changes in this Guide Can Protect Children and Workers

- This Guide contains practical steps for lead safety.
- With small changes in work practices, workers can protect themselves, their families, and their customers, especially children, from lead exposure.

## Painting, Home Improvement, and Maintenance Work in Older Homes Can Endanger Children

- Most homes built before 1978 contain lead-based paint.
- Doing work improperly can create a lot of paint chips and dust that may contain lead.
- Lead in paint chips, dust, and soil gets on children's hands and toys which they may put in their mouths.
- Lead can make children very sick and cause permanent brain and nerve damage, learning difficulties, and behavior problems.

## Poor Maintenance Also Endangers Children

- Paint flaking and peeling is often caused by moisture.
- Rubbing or impact on doors, windows, and trim can cause paint failure.

## Who Should Use This Guide?

- Building maintenance workers and supervisors
- Painters
- Repair, renovation, and remodeling contractors
- Property managers and owners
- Homeowners



## Ordering Additional Copies

Single copies of *Lead Paint Safety: A Field Guide for Painting, Home Maintenance, and Renovation Work* on paper or on CD-ROM can be ordered from the National Lead Information Center at 1-800-424-5323 or downloaded from the HUD Office of Healthy Homes and Lead Hazard Control web site at [www.hud.gov/offices/lead](http://www.hud.gov/offices/lead).

For information about obtaining multiple copies, contact the National Lead Information Center.

March 2001  
HUD-1779-LHC



# **SECTION 10**

## **The National Lead Laboratory Accreditation Program**

### **Environmental Accredited Lead Laboratories**

# The National Lead Laboratory Accreditation Program (NLLAP)

## Find an Accredited Lead Testing Laboratory

### *What is NLLAP?*

If you are a homeowner or prospective buyer of a home, or an owner or manager of a school or building, the presence of lead could be a concern and collection and analysis of potential sources of lead may be necessary. EPA established the National Lead Laboratory Accreditation Program (NLLAP) to recognize laboratories that demonstrate the ability to accurately analyze paint chip, dust, or soil samples for lead. Fixed-site laboratories, mobile laboratories, and testing firms that operate portable equipment are all eligible to obtain EPA recognition through NLLAP. An organization may choose to be recognized for one, two, or all three of the sample types (paint chips, dust, and soil) in NLLAP.

### *When Must Samples Be Analyzed by a Laboratory Recognized by EPA?*

In states and tribal lands where EPA is operating a federal Lead-Based Paint Activity program, any dust samples collected in a risk assessment, lead hazard screen, or clearance after a lead abatement must be analyzed by a laboratory or testing firm recognized by EPA under NLLAP.

In many states or tribal lands where the state or tribe is operating an EPA-authorized program, the same requirement for analysis of dust samples by an NLLAP-recognized laboratory or testing firm is in place. However, a state or tribe may have testing regulations that differ from the EPA requirements, even though the overall program is authorized by EPA. To be sure what the requirements are, check with the state or tribal program where you want to do sampling. For information on whether your state or tribe has a federal Lead-Based paint Activity program or a EPA-authorized state/tribal program, access the [most current state and tribal authorization map \(PDF\)](#) or call the National Lead Information Center at 1-800-424-LEAD (5323).

It is possible for a city or other local government to have its own additional regulations, so check in your locality as well for any testing requirements. In addition, a private individual may wish to have samples tested for lead. Find an [EPA-accredited laboratory](#) for lead sample analysis.

### *How Does NLLAP Work?*

NLLAP provides the public with a list of laboratories that have met EPA requirements and demonstrated the capability to accurately analyze paint chips, dust, or soil samples for lead. All laboratories recognized by NLLAP are required to undergo on-site audits conducted by accrediting organizations participating in NLLAP, and to perform successfully on a continuing basis in the Environmental Lead Proficiency Analytical Testing (ELPAT) Program. ELPAT is a laboratory performance proficiency testing program mandated by the American Industrial Hygiene Association (AIHA).

Laboratories and other testing firms on the NLLAP list follow the [Laboratory Quality System Requirements \(LQSR\), version 3 \(PDF\)](#) developed by EPA. The LQSR identifies the minimum requirements for use by accreditation organizations when evaluating laboratories performing environmental testing activities under NLLAP. It is based on requirements of the International Organization for Standardization and International Electrochemical Commission (ISO/IEC) Standard 17025:2005(E), "General requirements for the competence of testing and calibration laboratories."

Other organizations, including states, may apply to EPA to enter into a Memorandum of Understanding with EPA to become accrediting organizations in NLLAP. EPA has developed a [Model Memorandum of Understanding \(PDF\)](#) for other potential NLLAP accrediting organizations.

EPA currently recognizes five organizations as accrediting bodies for NLLAP that accredit laboratories for lead sample analysis. They are:

- [American Industrial Hygiene Association Laboratory Accreditation Programs, LLC \(AIHA LAP, LLC\) Exit](#)
- [American Association for Laboratory Accreditation \(A2LA\) Exit](#)
- [Perry Johnson Laboratory Accreditation, Inc. \(PJLA\) Exit](#)
- [ANSI-ASQ National Accreditation Board/ACCLASS Exit](#)
- [Laboratory Accreditation Bureau Exit](#)

To apply for accreditation as a lead sample analysis laboratory under NLLAP, contact one of these five accrediting bodies.

### ***What Other Information is Available on NLLAP?***

Other reports and documents related to NLLAP are listed below. These can be obtained by following the links below and accessing the documents on-line.

- [NLIC # 376] [Selecting a Laboratory for Lead Analysis: The EPA National Lead Laboratory Accreditation Program \(PDF\)](#), April 1999 (EPA 747-F-99-002)
- [NLIC # 371] [Pb-Based Paint Laboratory Operations Guidelines: Analysis of Pb in Paint, Dust, and Soil, Revision 1.0 \(PDF\)](#), May 1993 (EPA 747-R-92-006)
- [NLIC # 373] [Survey of State Lead Laboratory Accreditation Programs \(PDF\)](#), November 1996 (EPA 747-R-96-010)
- [NLIC # 377] [Laboratory Accreditation Program Guidelines: Measurement of Lead in Paint, Dust, and Soil \(PDF\)](#), March 1992 (EPA 747-R-92-001)
- [Pb-Based Paint Laboratory Accreditation: Curricula Recommendations for Assessor Training Programs, Revision 1.0 \(PDF\)](#), May 1993 (EPA 747-R-92-005). [Can be ordered by contacting the National Technical Information Service (NTIS) at 800-553-NTIS (6847) and ordering NTIS document number PB2001-105348.]
- [NLIC # 369] [National Lead Laboratory Accreditation Program: Double-Blind Proficiency Testing Pilot Study \(PDF\)](#), March 2001 (EPA 747-R-01-004)

State or Country	Accrediting* Organization	Company Name, City & Phone	Lab Type	Commercial Availability	Matrix Recognized		
					Paint Chips	Soil	Dust Wipes
AK	1	ATC Group Services, LLC Anchorage (907) 258-8661	Fixed Site	Yes	X	X	X
AZ	1	EMC Labs, Inc. Phoenix (480) 940-5294	Fixed Site	Yes	X	X	X
AZ	1	Fiberquant Analytical Services Phoenix (602) 276-6139	Fixed Site	Yes	X	X	X
AZ	1	Salt River Project Tempe 6022364132	Fixed Site	No	X		
AZ	1	TestAmerica Laboratories, Inc. Phoenix (602) 659-7679	Fixed Site	Yes		X	X
CA	1	AIH Laboratory Anaheim (562) 860-2201	Fixed Site	Yes	X	X	X
CA	1	Asbestos TEM Laboratories, Inc. Berkeley (510) 704-8930	Fixed Site	Yes	X	X	X
CA	1	Eurofins EMLab P&K Irvine (650) 228-6938	Fixed Site	Yes	X		X
CA	2	EMSL Analytical, Inc. San Leandro (510) 895-3675	Fixed Site	No	X	X	X
CA	1	Envirocheck, Inc. Burbank (714) 937-0750	Fixed Site	No	X	X	X
CA	1	Envirocheck, Inc. Orange (714) 937-0750	Fixed Site	Yes	X	X	X
CA	1	Environmental Health Laboratory, CA DPH Richmond (510) 620-2864	Fixed Site	No	X	X	X
CA	1	SGS Forensic Laboratories, Inc. Hayward (310) 294-4365	Fixed Site	Yes	X	X	X
CA	1	SGS Forensic Laboratories, Inc. Rancho Dominguez (310) 294-4365	Fixed Site	Yes	X	X	X
CA	1	H.M Pitt Labs, Inc. San Diego (619) 474-8548	Fixed Site	Yes	X	X	X

Organization accredited by:

\*American Industrial Hygiene Association = 1

\*American Association for Laboratory Accreditation = 2

\*Perry Johnson Laboratory Accreditation = 3

\*ANSI-ASQ Natl. Accreditation Board/ACCLASS = 4

State or Country	Accrediting* Organization	Company Name, City & Phone	Lab Type	Commercial Availability	Matrix Recognized		
					Paint Chips	Soil	Dust Wipes
CA	1	LA Testing South Pasadena (800) 220-3675	Fixed Site	Yes	X	X	X
CA	1	LA Testing Huntington Beach (800) 220-3675	Fixed Site	Yes	X	X	X
CA	1	Lawrence Livermore Nat'l Laboratory Livermore (925) 423-7348	Fixed Site	No	X		X
CA	1	Long Beach Public Health Laboratory Long Beach (562) 570-4262	Fixed Site	No	X	X	X
CA	1	Micro Analytical Labs, Inc. Emeryville (510) 653-0824	Fixed Site	Yes	X	X	X
CA	2	MicroTest Laboratories, Inc. Rancho Crodova 916- 567-9808	Fixed Site	Yes	X	X	X
CA	1	Navy Enviro Preventive Med Unit 5 San Diego (619) 556-1427	Fixed Site	No	X		X
CO	1	Reservoirs Environmental Services, Inc. Denver (303) 964-1986	Fixed Site	Yes	X	X	X
CT	1	EnviroMed Services, Inc. Meriden (203) 238-4846	Fixed Site	Yes	X	X	X
CT	1	State of Connecticut Dept. of Public Hth Rocky Hill (860) 509-8554	Fixed Site	No	X	X	X
DE	1	Batta Laboratories, Inc. Newark (302) 737-3376	Fixed Site	Yes	X	X	X
FL	1	EMSL Analytical, Inc. Orlando (800) 220-3675	Fixed Site	Yes	X	X	X
GA	1	Analytical Environmental Services, Inc. Atlanta (770) 457-8177	Fixed Site	Yes	X	X	X
GA	1	Materials Analytical Services, Inc. Suwanee (770) 866-3210	Fixed Site	Yes	X	X	X

Organization accredited by:

\*American Industrial Hygiene Association = 1

\*American Association for Laboratory Accreditation = 2

\*Perry Johnson Laboratory Accreditation = 3

\*ANSI-ASQ Natl. Accreditation Board/ACCLASS = 4

State or Country	Accrediting* Organization	Company Name, City & Phone	Lab Type	Commercial Availability	Matrix Recognized		
					Paint Chips	Soil	Dust Wipes
HI	1	Hawaii Analytical Laboratory, LLC Honolulu (808) 735-0422	Fixed Site	Yes	X	X	X
HI	2	Pearl Harbor Naval Shipyard, IMF QA Dept Pearl Harbor (808) 471-3604	Fixed Site	No	X		
IA	1	University of Iowa Hygienic Laboratory Ankeny (515) 725-1600	Fixed Site	No	X	X	X
IL	1	EMSL Analytical, Inc. Hillside (800) 220-3675 X 1256	Fixed Site	Yes	X	X	X
IL	1	Federal Occupational Health Laboratory Chicago (312) 886-0413 X 111	Fixed Site	No	X	X	X
IL	1	Illinois Dept of Public Health Chicago (312) 793-4251	Fixed Site	No	X	X	X
IL	1	Metro Technology Labortory, Inc. Chicago (312) 850-3300	Fixed Site	No			
IL	1	STAT Analysis Corporation Chicago (312) 733-0551	Fixed Site	Yes	X	X	X
IN	1	ACT Environmental Services, Inc. Indianapolis (317) 756-9320	Fixed Site	Yes	X	X	X
IN	1	EMSL Analytical, Inc. Indianapolis (800) 220-3675 X 1256	Fixed Site	Yes	X	X	X
IN	1	Marion County Health Department Indianapolis (317) 221-4672	Fixed Site	No	X	X	X
KY	1	Kentucky Cabinet for Health Services Frankfort (502) 564-4446 X 4439	Fixed Site	No	X	X	X
LA	2	EMSL Analytical Baton Rouge (223) 755-1920	Fixed Site	Yes	X	X	X
MA	1	Con-Test Analytical East Longmeadow (413) 525-2332 X41	Fixed Site	Yes	X	X	X
MA	1	EMSL Analytical Woburn (800) 220-3675	Fixed Site	Yes	X	X	X

Organization accredited by:

\*American Industrial Hygiene Association = 1

\*American Association for Laboratory Accreditation = 2

\*Perry Johnson Laboratory Accreditation = 3

\*ANSI-ASQ Natl. Accreditation Board/ACCLASS = 4

State or Country	Accrediting* Organization	Company Name, City & Phone	Lab Type	Commercial Availability	Matrix Recognized		
					Paint Chips	Soil	Dust Wipes
MA	1	ProScience Analytical Services, Inc. Woburn (781) 935-3212	Fixed Site	Yes	X	X	X
MD	1	AMA Analytical Services, Inc. Lanham (301) 459-2640	Fixed Site	Yes	X	X	X
MD	2	EMSL Analytical, Inc. Beltsville (301) 937-5700	Fixed Site	Yes	X	X	X
MD	2	Martel laboratories Towson (410) 825-7790 X 105	Fixed Site	Yes	X	X	X
MD	1	Nan Technologies, Inc. Halethorpe (410) 800-4263	Fixed Site	Yes			X
MD	2	Microbac Laboratories, Inc. Baltimore (410) 633-1800	Fixed Site	Yes	X	X	X
MD	2	US Army-Ctr Health Promotion & Prevent Med Aberdeen Proving Grounds (410) 436-8399	Fixed Site	No	X	X	X
ME	1	Health & Environmental Testing Laboratory Augusta (207) 287-1896	Fixed Site	No	X	X	X
MI	1	Apex Research Whitmore Lake (734) 449-9990	Fixed Site	Yes	X	X	X
MI	1	Accurate Analytical Testing, LLC Romulus (734) 699-5227	Fixed Site	Yes	X	X	X
MI	1	Bureau Veritas North America, Inc Novi (248) 3443028	Fixed Site	Yes	X	X	X
MI	1&2	GPI Laboratories, Inc. Grand Rapids (616) 940-3112 X122	Fixed Site	Yes	X	X	X
MI	1	Michigan Dept. of Health and Human Services Lansing (517) 335-8859	Fixed Site	No		X	X
MN	1	EMSL Analytical Minneapolis (612) 607-6457	Fixed Site	Yes	X	X	X
MN	2	Elegend Technical Services, Inc St. Paul 651-221-4078	Fixed Site	Yes	X	X	X

Organization accredited by:

\*American Industrial Hygiene Association = 1

\*American Association for Laboratory Accreditation = 2

\*Perry Johnson Laboratory Accreditation = 3

\*ANSI-ASQ Natl. Accreditation Board/ACCLASS = 4

State or Country	Accrediting* Organization	Company Name, City & Phone	Lab Type	Commercial Availability	Matrix Recognized		
					Paint Chips	Soil	Dust Wipes

MO	1	EMSL Analytical St. Louis (800) 220-3675	Fixed Site	Yes	X	X	X
MO	1	Environmental Health Laboratories Berkeley (314) 615-6833	Fixed Site	No	X	X	X
MO	1	Missouri Department of Health SPHL Jefferson City (573) 751-3334	Fixed Site	No	X	X	X
NC	1	EMSL Analytical, Inc Pineville (800) 220-3675	Fixed Site	Yes	X	X	X
NC	1	EMSL Analytical, Inc Kernersville (800) 220-3675	Fixed Site	Yes	X	X	X
NC	1	North Carolina State Lab of Public Health Raleigh 919-807-89801	Fixed Site	No	X	X	X
NC	1	Research Triangle Institute Research Triangle Park (919) 541-6366	Fixed Site	No	X	X	X
NC	1	Scientific Analytical Institute, Inc. Greensboro (336) 292-3888	Fixed Site	Yes	X	X	X
NJ	1&2	EMSL Analytical, Inc. Cinnaminson (856) 858-4800 X 5289	Fixed Site	Yes	X	X	X
NJ	1	Enviro-Probe, Inc. South Plainfield (732) 494-4600	Fixed Site	Yes	X	X	X
NJ	1	International Asbestos Testing Lab Mt. Laurel (856) 231-9449	Fixed Site	Yes	X	X	X
NY	1	Atlas Environmental Laboratory New York (212) 563-0400	Fixed Site	Yes	X		X
NY	1	Eastern Analytical Services, Inc. Elmsford (914) 592-8380	Fixed Site	Yes	X	X	X

Organization accredited by:

\*American Industrial Hygiene Association = 1

\*American Association for Laboratory Accreditation = 2

\*Perry Johnson Laboratory Accreditation = 3

\*ANSI-ASQ Natl. Accreditation Board/ACCLASS = 4

State or Country	Accrediting* Organization	Company Name, City & Phone	Lab Type	Commercial Availability	Matrix Recognized		
					Paint Chips	Soil	Dust Wipes
NY	1	EMSL Analytical, Inc. Carle Place (800) 220-3675	Fixed Site	Yes	X	X	X
NY	1	KAM Consultants Corporation Long Island City (718) 729-1997	Fixed Site	Yes	X	X	X
NY	1	Laboratory Testing Services, Inc. Long Island City (718) 389-3470	Fixed Site	Yes	X	X	X
NY	1	Metro Analytical Laboratories New York (212) 695-0165	Fixed Site	Yes			X
NY	1	SGS Galson East Syracuse (315) 671-3933	Fixed Site	Yes	X	X	X
OH	1	ALS Laboratory Group Cincinnati (513) 733-5336	Fixed Site	Yes	X	X	X
OH	1	AT Labs., a Unit of Assay Technology Boardman (330) 758-2048	Fixed Site	Yes			X
OH	2	District Board of Health Mahoning County Youngstown (330) 270-2841	Fixed Site	No	X	X	X
OH	1	USAFSAM/OEHTA Wright Patterson AFB (937) 938-3437	Fixed Site	No	X	X	X
OK	1	QuanTEM Laboratories Oklahoma City (405) 755-7272	Fixed Site	Yes	X	X	X
OR	3	WyEast Environmental Sciences Portland (503) 231-9320	Fixed Site	Yes	X		
PA	1	Criterion Laboratories, Inc. Bensalem (215) 244-1300 x28	Fixed Site	Yes	X	X	X
PA	2	Pennsylvania Department of Health Exton (610) 280-3464	Fixed Site	No	X	X	X

Organization accredited by:

\*American Industrial Hygiene Association = 1

\*American Association for Laboratory Accreditation = 2

\*Perry Johnson Laboratory Accreditation = 3

\*ANSI-ASQ Natl. Accreditation Board/ACCLASS = 4

State or Country	Accrediting* Organization	Company Name, City & Phone	Lab Type	Commercial Availability	Matrix Recognized		
					Paint Chips	Soil	Dust Wipes
PA	1	Intertek-PSI, Inc. Pittsburgh (412) 922-4000 X 286	Fixed Site	Yes	X	X	X
PA	1	R. J. Lee Group, Inc. Monroeville (724) 387-1995	Fixed Site	Yes	X	X	X
PR	1	Analytical Environmental Svcs International, Inc. Santurce (787) 722-0220	Fixed Site	Yes	X	X	X
RI	2	TTL Labs - Div.of R.I. Analytical Laboratories, Inc. Warwick (410) 737-8500 x112	Fixed Site	Yes	X	X	X
TN	1	BH&M Environmental Consultants Memphis (901) 277-5809	Fixed Site	Yes	X	X	X
TN	1	Central Laboratory, Shelby Co Health Dept Memphis (901) 544-7555	Fixed Site	Yes		X	X
TX	3	A & B Laboratories Houston (713) 453-6060	Fixed Site	Yes	X	X	X
TX	1	Armstrong Forensic Laboratory Arlington (817) 275-2691	Fixed Site	Yes	X	X	X
TX	1	Houston Health Department Laboratory Houston (832) 393-3976	Fixed Site	No	X	X	X
TX	1	CHEMTEX Port Arthur (409) 983-4575	Fixed Site	Yes	X		
TX	1	HIH Laboratory, Inc. Webster (281) 338-9000	Fixed Site	Yes	X	X	X
TX	1	J3 Resources, Inc. Houston (713) 290-0221	Fixed Site	Yes	X	X	X
UT	2	American West Analytical Laboratories Salt Lake City (801) 263-8686	Fixed Site	Yes	X	X	X
UT	1	ALS Laboratory Gorup Salt Lake City (801) 266-7700	Fixed Site	Yes	X	X	X
VA	1	Environmental Hazards Services, LLC Richmond (804) 275-4788	Fixed Site	Yes	X	X	X

Organization accredited by:

\*American Industrial Hygiene Association = 1

\*American Association for Laboratory Accreditation = 2

\*Perry Johnson Laboratory Accreditation = 3

\*ANSI-ASQ Natl. Accreditation Board/ACCLASS = 4

State or Country	Accrediting* Organization	Company Name, City & Phone	Lab Type	Commercial Availability	Matrix Recognized		
					Paint Chips	Soil	Dust Wipes
VA	1	Marine Chemist Service Newport News (757) 873-0933	Fixed Site	Yes	X	X	X
VA	1	Navy Environ & Prevent Medicine, Unit 2 CIHL Norfolk (757) 953-6562	Fixed Site	No	X		X
VA	2	Norfolk Naval Shipyard - Environ. Chem. Lab Portsmouth (757) 396-3207	Fixed Site	No	X		
VA	1	Newport News Shipbuilding Newport News (757) 688-2475	Fixed Site	Yes	X		
VA	1	SanAir Technologies Laboratory Powhatan (804) 897-1177	Fixed Site	Yes	X	X	X
VA	1	Schneider Laboratories, Inc. Richmond (804) 353-6778	Fixed Site	Yes	X	X	X
WA	1	NVL Laboratories, Inc. Seattle (206) 805-6405	Fixed Site	Yes	X	X	X
WI	1	City of Milwaukee Health Dept. Milwaukee (414) 286-3931	Fixed Site	No	X	X	X
WI	1	Wisconsin Occupational Health Lab Madison (608) 224-6216	Fixed Site	Yes	X	X	X
OM	1	18 AMDS Theater Preventive Medicine Flight Okinawa 011-81-98-938-1111	Fixed Site	Yes			X
ON/CA	1&2	EMSL Analytical, Inc. Mississauga, ON, CANADA (289) 997-4602	Fixed Site	Yes	X	X	X

Organization accredited by:

\*American Industrial Hygiene Association = 1

\*American Association for Laboratory Accreditation = 2

\*Perry Johnson Laboratory Accreditation = 3

\*ANSI-ASQ Natl. Accreditation Board/ACCLASS = 4

# **SECTION 11**

## **State of Tennessee Reciprocity Agreements**

## Summary of Reciprocity Acknowledgments to Date April 2003

This is a summary of the verbal reciprocity acknowledgment between the following states Alabama, Kentucky, and Mississippi as understood by Tennessee.

Each state reserves their decision rights to determine if an applicant's credentials meet or exceed their respective state's certification qualifications.

### **I. In General**

1. The states have agreed to accept applicant's examination scores on the *3<sup>rd</sup> Party National Certification Exams for Lead-Based Paint Abatement Professionals*, provided that the data can be verified. Verification is conducted via phone to the respective state and written notification supplied by that State to the individual completing the examination.
  - Passing score = 70% correctly answered or greater on the 3<sup>rd</sup> Party National examination.
2. The states have agreed that training providers must provide notification in the respective state in which the course is being held.  
(Note: Check with the respective state to determine the exact course notification date.)
3. The states have agreed on the following conditions regarding "non-English" speaking lead abatement worker training courses:
  - Languages other than English can be used to teach the lead abatement worker course only. The lead abatement worker course is the only course that EPA has had translated to another language, which is Spanish.
  - Non-English speaking worker training courses should have separate approval from the English-speaking worker training courses. For example, a training provider must not assume that since it has acquired approval based on English materials and English-speaking instructors that they automatically received approval for a non-English version of the course. The reverse also holds true for the English-speaking lead worker course. States will make it clear that training course approval/accreditation is language specific.
4. The states have agreed to share audit information from State accredited training providers that appear on the state's respective approval list to determine training program compliance.
  - The participating states agree that no training course will be accepted for the purpose of conferring certification/accreditation to a training provider until that training course discipline has had a "desk-top" audit completed.

A “desk-top” audit consists of:

Review of content, to determine whether minimum content is covered.

1. Determination (through review of agenda) if minimum time requirements are met. A training hour = 50 minutes.  
8 hours of training = 400 minutes.

Review of instructor qualifications

1. Determination of whether the training provider has the minimum necessary resources (equipment, materials, facilities, etc.) to conduct the training course. Are materials current with state and federal regulations.
2. Determination of whether the training provider is capable of conducting the training course. (Are learning objectives clearly stated?)
3. End-of- course examination review to determine if exam items (questions) are related to the subject being conducted and accuracy of the information.

An “on-site” audit when conducted will consist of at least:

1. Audits will be conducted using the appropriate audit format developed in conjunction with the SELC group.
  2. Confirmation that curricula reviewed by “desk-top” is in fact used in training course.
  3. Check facilities, equipment – Sufficient space? Heating and air? Functioning hands-on equipment? Lighting, distractions, etc.?
  4. Instructor competence – Can the instructor actually teach? What teaching methods are used? Can instruction be improved? Does the instructor follow the written agenda and/or inform the class when changes are necessary? Does the instructor stress the learning objectives in a timely manner?
  5. Hands-on assessment – Hands-on must be evaluated in the form of skills demonstration by the student, and the criteria must be defined in terms of performance criteria.
  6. Hands-on consists of 8 hours (400 minutes).
- End-of Course Examinations administrated by a state approved training provider must meet the following minimum requirements for the information to be shared.
    1. All disciplines must correctly answer 70% of the end-of-course exam.
    2. Minimum of 25 questions on worker initial course end-of-course exam.

3. Minimum of 50 questions on all other disciplines initial course end-of-course exam.
4. Minimum of 25 questions on any refresher course end-of-course exam.

(Note: Check with respective state for a clear determination on number of end-of-course exam questions.)

5. The states agree that principal instructors and guest instructors must successfully complete at least sixteen (16) hours of any EPA-accredited or EPA-authorized State or Tribal-accredited lead-specific training course for which they plan to provide instructions.

The principal and/or guest instructor must meet the following requirements:

1. At least two (2) years of experience, education, or training in teaching Workers or adults; or
2. A bachelor's or graduate degree in building construction technology; engineering, industrial hygiene, safety, public health, education, business administration or program management or a related field; or
3. Two years of experience in managing a training program specializing in environmental hazards; and
4. Demonstrated experience, education, or training in the construction industry including lead or asbestos abatement, painting, carpentry, renovation, remodeling, occupational safety and health, or industrial hygiene.

# **SECTION 12**

## **EXCERPT**

### **HUD Guidelines for the Evaluation and Control of Lead-Based Paint Hazards in Housing, Second Edition, July 2012**

**Table of Contents  
Chapter 1: Introduction  
Glossary of Terms**

# Table Of Contents: Guidelines 2<sup>nd</sup> Edition

ACKNOWLEDGEMENTS ..... iii

PREFACE ..... v

## CHAPTERS

Chapter 1	Introduction .....	1–1
Chapter 2	Where to Go for Help – Qualifications, Roles and Resources .....	2–1
Chapter 3	Before You Begin – Planning To Control Lead Hazards.....	3–1
Chapter 4	Lead-Based Paint and Housing Renovation .....	4–1
Chapter 5	Risk Assessment and Reevaluation .....	5–1
Chapter 6	Ongoing Lead-Safe Maintenance .....	6–1
Chapter 7	Lead-Based Paint Inspection.....	7–1
Chapter 8	Resident Protection and Worksite Preparation .....	8–1
Chapter 9	Worker Protection .....	9–1
Chapter 10	Housing Waste.....	10–1
Chapter 11	Interim Controls .....	11–1
Chapter 12	Abatement .....	12–1
Chapter 13	Abatement by Encapsulation.....	13–1
Chapter 14	Cleaning.....	14–1
Chapter 15	Clearance.....	15–1
Chapter 16	Investigation and Treatment of Dwellings that House Children with Elevated Blood Lead Levels .....	16–1
Chapter 17	(Reserved for future use).....	17–1
Chapter 18	Lead-Based Paint and Historic Preservation.....	18–1

GLOSSARY..... G–1

## APPENDICES

Appendix 1	Units of Measure Used in the Lead-Based Paint Field .....	APP 1–1
Appendix 2	CDC’s Childhood Lead Poisoning Prevention Program .....	APP 2–1
Appendix 3	U.S. EPA Regional Offices .....	APP 3–1
Appendix 4	OSHA Regional Offices and State Programs .....	APP 4–1
Appendix 5	EPA Training, Certification and Accreditation Programs .....	APP 5–1
Appendix 5.1	Structured On-the-Job Training (OJT) vs. Unstructured OJT .....	APP 5.1–1
Appendix 6	HUD, EPA, OSHA, CPSC, and NPS Lead Paint Rules .....	APP 6–1
Appendix 7.1	(Reserved for future use) .....	APP 7.1–1



**Appendix 7.2** Types of Lead-Based Paint Enclosure Systems .....APP 7.2–1

**Appendix 7.3** Generic Lead Based Paint Specifications .....APP 7.3–1

**Appendix 7.4** Guidance on Specifications for Interim Control of Soil Lead Hazards..... APP 7.4–1

**Appendix 8.1** Example of a Pre-Rehabilitation Risk Assessment and Limited Paint Testing Report for a Single-Family Dwelling Operated By a Small-Scale Owner .....APP 8.1–1

**Appendix 8.2** Example of a Risk Assessment Report for Large Multi-family Housing Development ..... APP 8.2–1

**Appendix 9** Lead-Based Paint Liability Insurance ..... APP 9–1

**Appendix 10** (Reserved for future use) ..... APP 10–1

**Appendix 10.1** State and Territorial Hazardous Waste Management Agencies ..... APP 10.1–1

**Appendix 11** One -Hour Waiting Period Rationale for Clearance Sampling ..... APP 11–1

**Appendix 12** Statistical Rationale for Sample Sizes and Percentages Used in Guidance for Inspecting in Multi-Family Housing..... APP 12–1

**Appendix 13.1** Wipe Sampling of Settled Dust for Lead Determination .....APP 13.1–1

**Appendix 13.2** Paint Chip Sampling..... APP 13.2–1

**Appendix 13.3** Collecting Soil Samples for Lead Determination .....APP 13.3–1

**Appendix 13.4** (Reserved for future use).....APP 13.4–1

**Appendix 13.5** EPA Information on Drinking Water.....APP 13.5–1

**Appendix 14.1** EPA-Recognized Laboratories for Analysis of Lead in Paint, Dust and Soil.....APP 14.1–1

**Appendix 14.2** (Reserved for future use).....APP 14.2–1

**Appendix 14.3** Procedure for the Preparation of Field Spiked Wipe Samples .....APP 14.3–1

**Appendix 15** OSHA Lead in Construction Guidance..... APP 15–1

**Appendix 16** CDC Guidance on Lead Poisoning Prevention..... APP 16–1

**FIGURES**

**Figure 1.1** Some paints contained 50% lead and were aggressively marketed..... 1–6

**Figure 1.2** Deteriorated residential paint on house trim ..... 1–7

**Figure 1.3** Paint deterioration ..... 1–7

**Figure 1.4** Title X’s Lead Hazard Control Framework ..... 1–11

**Figure 2.1** Many local health departments distribute information or conduct outreach activities at health fairs or community meetings..... 2–10

**Figure 2.2** Risk assessors and property owners planning housing rehabilitation may find an on-site meeting facilitates communication about lead-based paint hazards on a property ..... 2–14

**Figure 3.1** Assessing the physical condition of a property ..... 3–8

<b>Figure 3.2</b>	HUD’s American Healthy Homes Survey found that, in 2005–2006, most pre-1940 units contained some lead-based paint .....	3–9
<b>Figure 3.3</b>	Worker caulking painted surfaces as part of ongoing lead-safe maintenance .....	3–11
<b>Figure 3.4</b>	Units with children have a higher priority for evaluation and control than other units .....	3–12
<b>Figure 3.5</b>	Determination of Lead Hazard Control Strategy: Decision-making Logic.....	3–15
<b>Figure 4.1</b>	Sanding wooden floors can generate significant amounts of dust.....	4–4
<b>Figure 4.2</b>	Torching and burning old paint is a prohibited work practice that can generate lead fumes.....	4–6
<b>Figure 4.3</b>	This worksite was not properly prepared for lead-disturbing work by removing the occupant’s belongings.....	4–10
<b>Figure 4.4</b>	HEPA vacuuming is an important step in the specialized cleaning process .....	4–10
<b>Figure 5.1</b>	Lead Hazard Screen Decision Logic.....	5–12
<b>Figure 5.2</b>	Risk Assessor interviewing a resident.....	5–20
<b>Figure 5.3</b>	Record of sampling locations and floor plan sketch.....	5–21
<b>Figure 5.4</b>	Forms of Paint Deterioration.....	5–25
<b>Figure 5.4a</b>	Peeling paint .....	5–25
<b>Figure 5.4b</b>	Alligatoring paint .....	5–25
<b>Figure 5.4c</b>	Blistering paint .....	5–25
<b>Figure 5.5</b>	Baseboard showing deteriorated paint less than the de minimis amounts.....	5–28
<b>Figure 5.6a</b>	Friction hazard on stairs pre-treatment.....	5–30
<b>Figure 5.6b</b>	Friction hazard on stairs post-treatment.....	5–30
<b>Figure 5.7</b>	Impact surface on door and frame.....	5–31
<b>Figure 5.8</b>	Chewable surface showing teeth marks on window sill.....	5–32
<b>Figure 5.9</b>	Soil lead hazard at dripline.....	5–32
<b>Figure 5.10</b>	Soil lead hazard at dripline of garage.....	5–34
<b>Figure 5.11a</b>	Dust sampling equipment.....	5–37
<b>Figure 5.11b</b>	Pulling a wipe from container .....	5–37
<b>Figure 5.11c</b>	Making first (horizontal) pass of clearance wipe.....	5–37
<b>Figure 5.11d</b>	Folding wipe.....	5–37
<b>Figure 5.11e</b>	The second (vertical) pass.....	5–37
<b>Figure 5.11f</b>	Placing the used wipe into hard container.....	5–37
<b>Figure 5.12</b>	Floor sampling in high traffic area near entry.....	5–39
<b>Figure 5.13</b>	Window sill and trough.....	5–40

<b>Figure 5.14</b>	Illustrations of window trough and interior window sill.....	5-41
<b>Figure 5.15</b>	Example of basic dust sampling plan. ....	5-43
<b>Figure 5.16</b>	Dust testing window sill for presence of friction hazard.....	5-44
<b>Figure 5.17</b>	Damage to painted surface caused by paint chip sampling.....	5-52
<b>Figure 5.18</b>	Baby's bed exhibiting deteriorated paint and evidence of teeth marks. ....	5-53
<b>Figure 5.19a-c</b>	Soil sampling.....	5-55
<b>Figure 5.20</b>	Example of targeted dwelling selection.....	5-74
<b>Figure 5.21</b>	Example of soil hazard determination in non-play areas. ....	5-78
<b>Figure 5.22</b>	Example of lead hazard control policy .....	5-83
<b>Figure 6.1</b>	Visual Assessment.....	6-9
<b>Figure 6.2</b>	Opening screen from HUD's first on-line visual assessment training curriculum. Updates may occur .....	6-11
<b>Figure 6.3</b>	An area of bare soil beneath a window with deteriorated paint.....	6-14
<b>Figure 6.4</b>	Bare soil in Figure 6.3 covered with mulch (the window was sealed during the process of controlling the bare soil).....	6-23
<b>Figure 6.5</b>	Unit turnover is an excellent time to conduct the visual assessment and perform lead safe maintenance activities. ....	6-27
<b>Figure 6.6</b>	Clean up supplies. ....	6-32
<b>Figure 7.1</b>	One type of XRF instrument displays its reading of a testing combination .....	7-12
<b>Figure 7.2</b>	Child's bed showing teeth marks in painted surface .....	7-21
<b>Figure 7.3</b>	Multi-family Decision Flowchart.....	7-43
<b>Figure 7.4</b>	Preparation to take paint chip sample .....	7-46
<b>Figure 7.5</b>	Removing paint chip sample.....	7-46
<b>Figure 7.6</b>	Damage caused by removing paint chip sample.....	7-47
<b>Figure 7.7</b>	Inspectors must operate XRFs at a safe distance from others .....	7-52
<b>Figure 8.1</b>	Prohibiting resident entry into work area by use of containment barrier .....	8-5
<b>Figure 8.2</b>	EPA's "Renovate Right" Pamphlet.....	8-7
<b>Figure 8.3</b>	Structural deficiency .....	8-8
<b>Figure 8.4</b>	Example of structural deficiency needing repair prior to work.....	8-8
<b>Figure 8.5</b>	One example of a commercial-type HEPA vacuum. ....	8-9
<b>Figure 8.6</b>	Inadequate worker protection during a large overhead paint stripping project. ....	8-9
<b>Figure 8.7</b>	Placing coffee station in the work area is an unsafe work practice. ....	8-9
<b>Figure 8.8</b>	Floor plastic in work area.....	8-15
<b>Figure 8.9</b>	Plastic barrier between living space and work area. ....	8-16

<b>Figure 8.10</b>	Interior warning sign. ....	8-17
<b>Figure 8.11</b>	Exterior warning sign for project shown in Figure 8.10. ....	8-17
<b>Figure 8.12</b>	Items that are too large to move should be sealed completely and taped. ....	8-19
<b>Figure 8.13</b>	Removal and wrapping contaminated carpet. ....	8-20
<b>Figure 8.14</b>	Exterior containment of polyethylene sheeting lines the narrow walkway between two houses. ....	8-25
<b>Figure 8.15</b>	Exterior containment on building and window; ladder kept on plywood. ....	8-25
<b>Figure 8.16</b>	Example of barrier tape used as an occupant protection measure ....	8-26
<b>Figure 8.17</b>	Pre-cleaning window with HEPA vacuum. ....	8-27
<b>Figure 8.18</b>	Sample Informed Consent Form for Residents of Housing for the Elderly. ....	8-31
<b>Figure 10.1</b>	Separate waste into categories during work. ....	10-4
<b>Figure 10.2</b>	Radiators and trim are examples of intact architectural components that are low-level lead waste. ....	10-6
<b>Figure 10.3</b>	Concentrated lead waste. ....	10-8
<b>Figure 10.4</b>	Paint chips should be double-bagged and seams sealed. ....	10-8
<b>Figure 10.5</b>	EPA regulates disposal of hazardous waste ....	10-9
<b>Figure 11.1</b>	Moisture-Related Causes of Paint Failure. ....	11-24
<b>Figure 11.2</b>	HEPA Vacuum Sanders. ....	11-30
<b>Figure 11.3</b>	Window before and after friction treatment. ....	11-35
<b>Figure 11.4</b>	Examples of impact and chewable surfaces. ....	11-36
<b>Figure 11.5</b>	Prepare the worksite and pre-clean the window ....	11-37
<b>Figure 11.6</b>	Remove parting bead. ....	11-37
<b>Figure 11.7</b>	Remove the bottom sash, sash weights and stops. ....	11-38
<b>Figure 11.8</b>	Remove sash controls/weights. ....	11-38
<b>Figure 11.9</b>	Window after removal of sash weights. ....	11-38
<b>Figure 11.10</b>	Rebuild damaged sash with filler or putty. ....	11-38
<b>Figure 11.11</b>	Wet plane edges of sash to fit new jamb liners. ....	11-38
<b>Figure 11.12</b>	Vacuum window again. ....	11-38
<b>Figure 11.13</b>	Fit sashes into jamb liners. ....	11-39
<b>Figure 11.14</b>	Reinstall sash into jamb. ....	11-39
<b>Figure 11.15</b>	Stabilizing paint on doors: Wet planning and wet sanding ....	11-40
<b>Figure 11.16</b>	Before and after stair treatments. ....	11-41
<b>Figure 11.17</b>	Covering Stairs with Tread Guards. ....	11-42

<b>Figure 11.18</b>	Shoe Molding Is an Acceptable Impact Surface Treatment for Baseboards .....	11-42
<b>Figure 11.19</b>	Corner Bead Coverings Can Be Used on Outside Corners of Walls.....	11-42
<b>Figure 11.20</b>	Turning a Window Sill and Trough Into a Smooth and Cleanable Surface.....	11-48
<b>Figure 11.21</b>	How to Use a HEPA Vacuum .....	11-52
<b>Figure 11.22</b>	Changing HEPA vacuum filter .....	11-54
<b>Figure 11.23</b>	Carpet with debris and after cleaning .....	11-58
<b>Figure 11.24</b>	Air vent before and after cleaning.....	11-59
<b>Figure 11.25</b>	Clean Air Vent Registers .....	11-59
<b>Figure 11.26</b>	Walk-Off Mats .....	11-60
<b>Figure 11.27</b>	Thorny Bushes as a Land Use Control.....	11-65
<b>Figure 11.28</b>	Using Fencing as an Interim Control.....	11-65
<b>Figure 12.1</b>	Removing and Replacing Trim: interior (left), exterior (right) .....	12-19
<b>Figure 12.2</b>	Protecting the interior of a unit for exterior window abatement .....	12-20
<b>Figure 12.3</b>	Replacement window system .....	12-20
<b>Figure 12.4</b>	Pre-and post-abatement interior doors .....	12-21
<b>Figure 12.5</b>	A metal railing before abatement.....	12-22
<b>Figure 12.6</b>	Installation of replacement siding.....	12-22
<b>Figure 12.7</b>	Certified workers are needed to replace siding when the project's intent is lead abatement.....	12-22
<b>Figure 12.8</b>	Line surfaces with plastic in the work area (left) and pathways (right) .....	12-23
<b>Figure 12.9</b>	Example of a Diagram Showing the Location of Lead-Based Paint Enclosures .....	12-25
<b>Figure 12.10</b>	Installing underlayment and new flooring as a suitable LBP enclosure method.....	12-29
<b>Figure 12.11</b>	Enclosed stairs .....	12-30
<b>Figure 12.12</b>	Seal All Seams for Enclosure.....	12-31
<b>Figure 12.13</b>	Prohibited work practices (traditional abrasive blasting (left) and grinding without HEPA exhaust).....	12-34
<b>Figure 12.14</b>	Using a heat gun to remove paint is labor-intensive.....	12-36
<b>Figure 12.15</b>	HEPA-filtered power tools .....	12-37
<b>Figure 12.16</b>	Wet scraping (left) .....	12-38
<b>Figure 12.17</b>	Scraping tools (right) .....	12-38
<b>Figure 12.18</b>	Vacuum blasting is not often used on housing .....	12-39
<b>Figure 12.19</b>	Needle Gun with HEPA Exhaust Ventilation .....	12-39



<b>Figure 12.20</b>	Workers should wear protective clothing when using chemicals .....	12-40
<b>Figure 12.21</b>	Eye- and body-wash stations are required when working with corrosive or irritant chemicals. ....	12-41
<b>Figure 12.22</b>	Replacing resident pathway after soil removal.....	12-47
<b>Figure 12.23</b>	Preparing to pave high traffic area .....	12-49
<b>Figure 13.1</b>	Encapsulating a floor with vinyl tiles.....	13-8
<b>Figure 13.2</b>	Deteriorated paint on surfaces that are unsuitable for encapsulation.....	13-8
<b>Figure 13.3</b>	Encapsulated historic components.....	13-13
<b>Figure 13.4</b>	Encapsulant failure. ....	13-21
<b>Figure 14.1</b>	There are many brands of HEPA vacuums on the market. ....	14-8
<b>Figure 14.2</b>	Vacuum with a HEPA filter and special attachments. ....	14-10
<b>Figure 14.3</b>	Sizes of HEPA vacuums and attachments.....	14-11
<b>Figure 14.4</b>	Three-bucket cleaning system. ....	14-13
<b>Figure 14.5</b>	HEPA vacuum and wet wash technology .....	14-13
<b>Figure 14.6</b>	Removing large debris. ....	14-15
<b>Figure 14.7</b>	Exterior clean up.....	14-16
<b>Figure 14.8</b>	Vacuums the floor containment.....	14-17
<b>Figure 14.9</b>	Inspecting for completeness of the work performed. ....	14-19
<b>Figure 14.10</b>	The HEPA Vacuum-Wet Wash-HEPA Vacuum Cycle Helps Meet Clearance Standards. ....	14-20
<b>Figure 14.11</b>	Wet Cycle Requires Washing All Surfaces with Suitable Detergents. ....	14-20
<b>Figure 14.12</b>	Use a Three-Bucket System and Then HEPA Vacuum Again to Minimize Recontamination.....	14-20
<b>Figure 14.13</b>	HEPA vacuum all surfaces a final time.....	14-20
<b>Figure 15.1</b>	Windows sealed to prevent dust migration .....	15-13
<b>Figure 15.2</b>	Visible paint chips and debris in soil .....	15-14
<b>Figure 15.3</b>	Visible dust Indicates recleaning is needed.....	15-19
<b>Figure 15.4</b>	Tracking of dust that may contain lead .....	15-19
<b>Figure 15.5</b>	Indications that children are present.....	15-26
<b>Figure 15.6</b>	A floor that may be tested.....	15-30
<b>Figure 15.7</b>	A windowsill and trough that may be tested.....	15-30
<b>Figure 15.8</b>	Window locations for dust sampling.....	15-31
<b>Figure 15.9</b>	Soil debris.....	15-34
<b>Figure 15.10</b>	Surfaces that may have been paint stripped .....	15-37

<b>Figure 16.1</b>	Health Department case managers work with parents and guardians of lead-poisoned children .....	16–6
<b>Figure 16.2</b>	Environmental investigations include sites where the child spends time.....	16–8
<b>Figure 18.1</b>	Delicate muntins and multi-pane sash on row houses.....	18–9
<b>Figure 18.2</b>	Window condition assessment.....	18–9
<b>Figure 18.3a</b>	Historic property before rehabilitation .....	18–10
<b>Figure 18.3b</b>	Historic property after rehabilitation.....	18–10
<b>Figure 18.4</b>	Wood features on historic properties .....	18–12
<b>Figure 18.5</b>	Doors to historic property before off-site stripping .....	18–13
<b>Figure 18.5b</b>	Doors to historic property after off-site stripping.....	18–13
<b>Figure 18.6</b>	Enclosure of stairs not appropriate in a historic property .....	18–14

## FORMS

<b>Form 5.0</b>	Questionnaire for a Lead Hazard Risk Assessment of an Individual Occupied Dwelling Unit. ....	5–99
<b>Form 5.1</b>	Building Condition Form for Lead Hazard Risk Assessment.....	5–101
<b>Form 5.2</b>	Field Report of Visual Assessment for Lead Hazard Risk Assessment.....	5–102
<b>Form 5.3</b>	Field Paint Chip Sampling Form.....	5–103
<b>Form 5.4a</b>	Field Sampling Form for Dust. (Single-Surface Sampling).....	5–104
<b>Form 5.4b</b>	Field Sampling Form for Dust. (Composite Sampling) .....	5–105
<b>Form 5.5</b>	Field Sampling Form for Soil.....	5–106
<b>Form 5.6</b>	Questionnaire for a Lead Hazard Risk Assessment of More Than Four Rental Dwelling Units. ....	5–107
<b>Form 5.7</b>	Format for an Executive Summary of a Lead Hazard Risk Assessment.....	5–111
<b>Form 6.0</b>	Report of Visual Assessment (for Ongoing Lead-Safe Maintenance).....	6–35
<b>Form 6.1</b>	Report of Visual Assessment of Bare Soil for Lead-Safe Maintenance.....	6–36
<b>Form 6.2</b>	Log of Visual Assessments for Ongoing Lead-Safe Maintenance .....	6–37
<b>Form 6.3</b>	Lead-Based Paint Inventory .....	6–38
<b>Form 6.3a</b>	Completed Lead-Based Paint Inventory for a Room/Space .....	6–39
<b>Form 6.4</b>	Lead Hazard Control Inventory.....	6–40
<b>Form 6.5</b>	Lead-Safe Maintenance Work Order .....	6–41

**Lead-Based Paint Inspection Forms ..... After 7–61**

<b>Form 7.1</b>	Single Family Housing LBP Testing Data Sheet – Blank	
<b>Form 7.1</b>	Single Family Housing LBP Testing Data Sheet – Completed	
<b>Form 7.2</b>	Calibration Check Test Results – Blank	
<b>Form 7.2</b>	Calibration Check Test Results – Completed	
<b>Form 7.3</b>	Substrate Correction Values – Blank	
<b>Form 7.3</b>	Substrate Correction Values – Completed	
<b>Form 7.4</b>	Selection of Housing Units – Blank	
<b>Form 7.4</b>	Selection of Housing Units – Completed	
<b>Form 7.5</b>	Multi-family Housing LBP Testing Data Sheet – Blank	
<b>Form 7.5</b>	Multi-family Housing LBP Testing Data Sheet – Completed	
<b>Form 7.6</b>	Multi-family Housing: Component Type Report – Blank	
<b>Form 7.6</b>	Multi-family Housing: Component Type Report – Completed	
<b>Form 13.1</b>	Encapsulant Patch Test Documentation .....	13–23
<b>Form 13.2</b>	Lead-Based Paint Encapsulation Visual Monitoring Form .....	13–27
<b>Form 15.1</b>	Visual Assessment - Lead Hazard Clearance Examination.....	15–45
<b>Form 15.2</b>	Field Sampling Form for Dust - Lead Hazard Clearance Examination (single-surface sampling).....	15–46
<b>Form 15.3</b>	Lead Hazard Clearance Report – Completed Example.....	15–47
<b>Form 15.4</b>	Clearance Report Review Worksheet .....	15–53
<b>Form 15.5</b>	Clearance Report Review Worksheet –Completed Example .....	15–54
<b>Form 16.1</b>	Resident Questionnaire for Investigation of Children with Elevated Blood Lead Levels (EBL) .....	16–23

**TABLES**

<b>Table 2.1</b>	Owner Responsibilities .....	2–4
<b>Table 3.1</b>	Summary of Steps in Planning Lead Hazard Control Projects.....	3–7
<b>Table 3.2</b>	Housing Units with Lead-Based Paint or Significant Lead-Based Paint Hazards .....	3–9
<b>Table 4.1</b>	Similarities between Lead Hazard Control and Renovation.....	4–5
<b>Table 5.1</b>	Comparison of Risk Assessment, Lead Hazard Screen, Lead-Based Paint Inspection, and Combination Inspection/Risk Assessment .....	5–10
<b>Table 5.2</b>	Percentage of Housing Units with Significant Lead-Based Paint Hazards, and Percentage with Bare Soil Lead Levels in Yard > 1200 ppm, United States, 2005-2006 .....	5–14
<b>Table 5.3</b>	Percentage of Component Types Coated with Lead-Based Paint, by Year of Construction, and by Interior or Exterior Location, United States, 2000 .....	5–16



<b>Table 5.4</b>	Illustrative List of Painted Components*.....	5–27
<b>Table 5.5</b>	Review of Previous Lead-Based Paint Inspections. ....	5–50
<b>Table 5.6</b>	Recommended Number of Play Areas To Be Sampled.....	5–57
<b>Table 5.7</b>	Recommended Number of Non-play Areas of Dripline/Foundation Areas. ....	5–58
<b>Table 5.8</b>	Recommended Number of Soil Samples in Non-play Areas of the Rest of the Yard Outside of Dripline/Foundation Areas. ....	5–59
<b>Table 5.9</b>	Risk Assessment Approach for Evaluations of Different Size.....	5–63
<b>Table 5.10</b>	Minimum Number of Targeted Dwellings to Be Sampled Among Similar Dwellings (random sampling may require additional units). ....	5–68
<b>Table 5.11</b>	Federal Hazard Levels for Lead Hazard Risk Assessments* .....	5–73
<b>Table 5.12</b>	Main Hazard Control Options That Could Be Identified in Risk Assessments Based on Actual Conditions.....	5–87
<b>Table 5.13</b>	Paint-Lead Hazards.....	5–92
<b>Table 5.14</b>	Soil-Lead Hazards .....	5–92
<b>Table 5.15</b>	Dust-Lead Hazards.....	5–93
<b>Table 7.1</b>	Examples of Interior and Exterior Building Component Types.....	7–18
<b>Table 7.2</b>	Examples of Distinct Testing Combinations .....	7–19
<b>Table 7.3</b>	Number of Units to Be Tested in Multi-family Building and Developments .....	7–38
<b>Table 8.1</b>	Interior Worksite Preparation (Not Including Windows) .....	8–13
<b>Table 11.1</b>	Finish Coats for Paint Stabilization.....	11–32
<b>Table 11.2</b>	Sticky Tape Technique for Removing Loose Paint on Impact Surfaces for Owner/Occupants or Residents.....	11–43
<b>Table 11.3</b>	Potential Sources of Lead-Containing House Dust.....	11–46
<b>Table 11.4</b>	Major Dust Reservoirs and Potential Dust Traps.....	11–47
<b>Table 11.5</b>	Rug Cleaning Steps and Approximate Time Per 10 Square Feet.....	11–57
<b>Table 11.6</b>	Grasses and Their Appropriate Applications.....	11–66
<b>Table 12.1</b>	Prohibited Lead-Based Paint Abatement Methods.....	12–13
<b>Table 12.2</b>	Comparison of Lead-Based Paint Abatement, Removal and Enclosure.....	12–17
<b>Table 12.3</b>	Steps To Install Drywall and Fiberboard on Interior Walls. ....	12–27
<b>Table 13.1</b>	Advantages and Disadvantages of Using Encapsulants.....	13–7
<b>Table 13.2</b>	Categories of Encapsulants.....	13–10
<b>Table 13.3</b>	Steps for Obtaining Proper Application and Installation of an Encapsulant System.....	13–22
<b>Table 14.1</b>	Summary Guidance on Cleaning Methods by Dustiness of Work and Condition of the Surface. ....	14–18



<b>Table 15.1</b>	Recommended Minimum Number and Location of Dust Samples.....	15–27
<b>Table 15.2</b>	Clearance Dust Standards (Single-Surface Wipe Samples).....	15–39
<b>Table 15.3</b>	Clearance Dust Standards (Composite Wipe Samples).....	15–41
<b>Table 15.4</b>	Hypothetical Example of Single-Surface Clearance Dust Sampling Data. ....	15–41
<b>Table 15.5</b>	Hypothetical Example of Composite Clearance Dust Sampling Data. ....	15–41
<b>Table 16.1</b>	Summary of Recommendations for Assessment and Remediation of Residential Lead Exposure.....	16–10
<b>Table 16.2</b>	Guidelines for Questions to Ask Regarding a Child’s Environmental History .....	16–12
<b>Table 16.3</b>	Common Sources of Lead Exposure to Consider in an Environmental Investigation .....	16–13
<b>Table 16.4</b>	Published Reports of Less Common Causes of Elevated Blood Lead levels (EBLs) in Children.....	16–16

# Chapter 1: Introduction

I. Legislative Basis and Relationship to Federal Programs and Regulations.....	1-3
A. Legislative Basis .....	1-3
B. Intended Audience .....	1-3
II. Background on Childhood Lead Poisoning, Sources of Lead in the Environment, and the Evolution of Lead Poisoning Prevention .....	1-4
A. Childhood Lead Poisoning.....	1-4
1. Health Hazards .....	1-4
2. Prevalence Rates.....	1-5
3. Highest Risk Populations .....	1-5
4. Health Screening.....	1-5
5. Updated CDC Recommendations .....	1-6
B. Causes of Childhood Lead Poisoning .....	1-6
1. Lead in Residential Paint .....	1-6
2. Lead-Based Paint in Housing.....	1-6
3. Lead in Surface Dust.....	1-7
4. Lead in Soil.....	1-7
5. Other Causes of Lead Poisoning .....	1-8
C. The Evolution of Prevention Approaches.....	1-8
1. Medical Treatment of Poisoned Children (Tertiary Treatment).....	1-8
2. Screening and Case Management Programs (Secondary Prevention).....	1-8
3. Primary Prevention .....	1-9
III. The Title X Regulatory Framework .....	1-9
A. Definition of “Lead-Based Paint Hazard” .....	1-9
B. Regulatory Framework for Lead Hazard Control .....	1-10
1. Evaluating Lead Hazards .....	1-11
2. Controlling Lead Hazards.....	1-12
C. Requirements To Ensure Quality Control .....	1-13
1. Training and Certification .....	1-13
2. Accreditation of Training Providers .....	1-13
3. Health-Based Standards .....	1-13
4. Performance Standards for Testing and Abatement Products.....	1-13
5. Laboratory Accreditation .....	1-14
D. State and Local Regulations.....	1-14
IV. Organization and Use of the Guidelines .....	1-14
A. Chapter Organization .....	1-14
1. Chapters 1-4: Background Information.....	1-14
2. Chapters 5-7: Hazard Evaluation and Ongoing Maintenance.....	1-15
3. Chapters 8-10: Preparation for the Project .....	1-15



4. Chapters 11-15: Hazard Control, Cleanup, and Clearance..... 1-15  
5. Chapters 16-18: Related Issues..... 1-16  
6. Glossary and Appendices..... 1-16  
**B. Units of Measurement..... 1-16**  
**C. Federal Lead Standards ..... 1-17**

**REFERENCES..... 1-18**

**FIGURES**

**Figure 1.1** Some paints contained 50% lead and were aggressively marketed ..... 1-6  
**Figure 1.2** Deteriorated residential paint on house trim..... 1-7  
**Figure 1.3** Paint deterioration. .... 1-7  
**Figure 1.4** Title X’s Lead Hazard Control Framework ..... 1-11

# Chapter 1: Introduction

## I. Legislative Basis and Relationship to Federal Programs and Regulations

### A. Legislative Basis

The *Guidelines* are issued pursuant to Section 1017 of the Residential Lead-Based Paint Hazard Reduction Act of 1992, which is often referred to as Title X (“Title Ten”) because it was enacted as Title X of the Housing and Community Development Act of 1992 (Public Law 102-550). The *Guidelines* are based on the concepts, definitions, and requirements set forth in Title X. Section III of this chapter describes the framework of concepts and definitions in Title X and the regulations issued pursuant to it.

As required by Section 1017, the *Guidelines* must be used for “federally supported work,” which is defined in the Act as “any lead hazard evaluation or reduction activities conducted in federally owned or assisted housing or funded in whole or in part through any financial assistance program” of the Department of Housing and Urban Development, the Department of Agriculture or the Department of Veterans Affairs. The Act defines “federally owned housing” as “residential dwellings owned or managed by a Federal agency, or for which a Federal agency is a trustee or conservator.” In this context, the term “Federal agency” includes HUD, the Department of Agriculture’s Rural Development – Housing and Community Facilities Programs, the Savings Association Insurance Fund, the General Services Administration, the Department of Defense, the Department of Veterans Affairs, the Department of the Interior, and the Department of Transportation. The term “federally assisted housing” is defined in the Act as “residential dwellings receiving *project-based* assistance under programs including:

“(A) section 221(d)(3) or 236 of the National Housing Act;

“(B) section I of the Housing and Urban Development Act of 1965;

“(C) section 8 of the United States Housing Act of 1937; or

“(D) sections 502(a), 504, 514, 515, 516 and 533 of the Housing Act of 1949.”

### B. Intended Audience

These *Guidelines* were developed and have been revised to provide technical guidance to the many individuals and groups involved with, or affected by, lead-based paint in residential housing units, and, to the extent appropriate, child-occupied facilities (see Appendix 6) including:

- ◆ Lead-based paint abatement contractors and abatement supervisors.
- ◆ Residential renovation contractors.
- ◆ Residential painters and painting contractors.
- ◆ Building maintenance personnel.
- ◆ Lead-based paint risk assessors, paint inspectors and sampling technicians.
- ◆ Lead-based paint training providers.
- ◆ Contractor certifying or licensing agencies.

- ◆ Residential building owners and managers, including: public housing agencies and Tribally-Designated Housing Entities (TDHEs); private, nonprofit housing development organizations; and private, for-profit landlords, managers, and building owners.
- ◆ Federal agency staff, such as from HUD, EPA, CDC, USDA, GSA, DoD, VA, DOI, DOT, and other agencies that own or manage residential properties and/or child-occupied facilities.
- ◆ State and local housing and community development agencies.
- ◆ State and local health agencies.
- ◆ Architects and designers.
- ◆ Environmental laboratory personnel.
- ◆ Environmental laboratory accreditation organizations.
- ◆ Real estate agents and brokers.
- ◆ Property and casualty insurers.
- ◆ Lenders and appraisers.

These *Guidelines* are intended for use by trained and certified lead-based paint professionals. Under HUD and EPA regulations, contractors and individuals must be trained and/or certified to conduct inspections, risk assessments, lead-based paint hazard reduction activities, and clearance examinations. Firms performing renovations that disturb lead-based paint (including interim controls) must be certified in Renovation, Remodeling and Repair, and have an adequate number of Certified Renovators on each job to perform the job safely. Federal agencies have developed different resources for non-professionals, such as the “Lead Paint Safety Field Guide.” Various outreach and education documents are posted at: <http://www.epa.gov/lead/pubs/leadpbed.htm>, or may be requested by calling the National Lead Information Center at 1-800-424-LEAD (toll-free). Hearing- or speech-challenged individuals may access this number through TTY by calling the toll-free Federal Relay Service at 800-877-8339.

## II. Background on Childhood Lead Poisoning, Sources of Lead in the Environment, and the Evolution of Lead Poisoning Prevention

As understanding of lead’s adverse health effects and the sources and pathways of exposure to children has improved, so has recognition of the seriousness of lead-based paint hazards.

### A. Childhood Lead Poisoning

Despite steady and impressive progress in reducing blood-lead levels (BLLs) among the U.S. population, childhood lead poisoning remains a major preventable environmental health problem in the United States.

#### 1. Health Hazards

Lead is highly toxic and affects virtually every system of the body. At high exposure levels, lead poisoning can cause convulsions, coma, and death. While adults can also suffer from excessive

lead exposures (discussed in Chapter 9), the groups most at risk are fetuses, infants, and children under age 6. At low levels, lead's neurotoxic effects have the greatest impact on children's developing brains and nervous systems, causing reductions in IQ and attention span, reading and learning disabilities, hyperactivity, and behavioral problems (Davis, 1993). These effects have been identified in many carefully conducted research studies (see the literature review in National Academy of Sciences, 1993). However, the vast majority of childhood lead poisoning cases go undiagnosed and untreated, because most poisoned children have no obvious symptoms.

## 2. Prevalence Rates

In October 1991, CDC formally revised its statement on *Preventing Lead Poisoning in Young Children* (CDC, 1991a), reducing its "level of concern" for childhood lead poisoning from the previous threshold of 25 micrograms/deciliter ( $\mu\text{g}/\text{dL}$ ) to 10  $\mu\text{g}/\text{dL}$ . (See section IV.B, below for a description of units of measurement for lead in blood, paint, dust, soil, air, and water.) This change was based on scientific evidence indicating that adverse health effects can occur at levels as low as 10  $\mu\text{g}/\text{dL}$ . In August 2005, CDC estimated that 310,000, or 0.7%, of American children under age 6 have BLLs above 10 $\mu\text{g}/\text{dL}$  (CDC, 2005). More recent research suggests that such effects occur at levels well below 10 $\mu\text{g}/\text{dL}$  (see, e.g., the literature review in CDC ACCLPP, 2012). No blood lead threshold for adverse health effects has been identified in children.

## 3. Highest Risk Populations

Lead poisoning affects children across all socioeconomic strata and in all regions of the country. However, because lead-based paint hazards are most severe in older, dilapidated housing, the poor in inner cities are disproportionately affected. In many such neighborhoods over half of all young children have lead poisoning. The National Health and Nutrition Examination Survey (NHANES) reported that, in 1999-2002, non-Hispanic blacks and Mexican Americans had higher percentages of elevated BLLs than non-Hispanic whites (Schwemberger, 2005). Although the disparity in risk for BLLs greater than or equal to 10 $\mu\text{g}/\text{dL}$  by income and race are no longer statistically significant; disparities by race/ethnicity and income still persist at lower blood lead levels (Jones, 2009).

## 4. Health Screening

In 1990, CDC called for a phase-in of universal blood-lead testing of all young children (unless it can be shown that the community has no lead poisoning problem) because most poisoned children do not exhibit easily identifiable symptoms and virtually all children are at risk (CDC, 1991b). The Medicaid Guidelines called for all children under age 6 to be tested (CMS, 1998). In 1993, the American Academy of Pediatrics (AAP) also revised its policy to recommend the routine screening of virtually all young children under age 6 (AAP, 1993). Because lead risk varies considerably by geography, CDC in 1997 recommended that State and local health departments assess local data on lead risks and develop lead-screening recommendations for health care providers in their jurisdictions, focusing on 1- and 2-year old children (CDC, 1997). CDC updated its statement in 2005 (see the Executive Summary in Appendix 16), while the U.S. Preventive Services Task Force (convened by the CDC) found that screening in asymptomatic children has not been demonstrated to be effective in improving clinical outcomes (Risshitelli, 2006).

## 5. Updated CDC Recommendations

CDC recommends that sources of lead in children’s environments be controlled or eliminated before children are poisoned, i.e. “primary prevention” (CDC, 2007; CDC, 2012a). CDC “emphasize[s] the importance of environmental assessments to identify and mitigate lead hazards before children demonstrate BLLs at or higher than the reference value” and has “adopt[ed] prevention strategies to reduce environmental lead exposures in soil, dust, paint, and water before children are exposed” through action by itself and others. Various counseling, monitoring, and community-wide prevention activities are recommended at various BLLs. Given that no safe blood lead level threshold in children has been identified, in 2012 CDC eliminated the use of a “blood lead level of concern” and redoubled its primary prevention efforts that remove lead before children are exposed. (CDC, 2012a) For further information, see Chapter 16.

## B. Causes of Childhood Lead Poisoning

Today, children in the United States are lead poisoned primarily through ingestion of lead-containing dust by normal hand-to-mouth and toy-to-mouth activity. Because lead is ubiquitous in industrial societies, there are many sources and pathways of lead exposure.

### 1. Lead in Residential Paint

The foremost cause of childhood lead poisoning in the United States today is lead-based paint and the accompanying contaminated dust and soil found in older houses (CDC, 1991b; Rabinowitz, 1985b; Jacobs, 1994). As early as 1897, lead-based paint was identified as a cause of childhood lead poisoning (Turner, 1897; Reich, 1992; Markowitz, 2000; Warren, 2002; Bellinger, 2006). Many countries prohibited the use of lead in residential paints as far back as 1922 (Rabin, 1989). Lead was a major ingredient in most interior and exterior oil house paints before 1950, with some paints containing as much as 50 percent lead by dry weight (see *Figure 1.1*). In the early 1950s, other ingredients became more popular, but some lead pigments, corrosion inhibitors, and drying agents were still used. Lead was first regulated in residential paint in 1972 at 0.5 percent and “banned” in 1978, meaning that paint could contain no more than 0.06 percent (600 parts per million) lead by dry weight (Rabin, 1989; Reich, 1992). The Consumer Product Safety Improvement Act of 2008 (Public Law 110-314) reduced the threshold to 0.009 percent (90 parts per million) lead by dry weight (CPSC, 2008).

### 2. Lead-Based Paint in Housing

HUD estimates that 38 million housing units have lead-based paint (Jacobs, 2002). The likelihood, extent, and concentration of lead-based paint increase with the age of the building.



FIGURE 1.1 Some paints contained 50% lead and were aggressively marketed.



FIGURE 1.2 Deteriorated residential paint on house trim.



FIGURE 1.3 Paint deterioration.

Because the greatest risk of paint deterioration is in dwellings built before 1950, older housing generally commands a higher priority for lead hazard controls (see Figures 1.2 and 1.3). (See Chapter 5 for lead-based paint prevalence data by building component type and prevalence of housing with significant lead-based paint hazards by year of construction.)

### 3. Lead in Surface Dust

The belief that in order to be poisoned children must eat lead-based paint chips is unfounded. The most common cause of poisoning is the ingestion – through hand-to-mouth transmission – of lead-contaminated

surface dust (Clark, 1991; Bellinger, 1991; Roberts, 1991; Chisolm, 1985; Farfel and Chisolm, 1990; Farfel, 1994a; Lanphear, 1998). HUD estimates that 15.5 million housing units have levels of lead in interior dust that exceed EPA standards (Jacobs, 2002). Lead-contaminated dust may be so fine that it cannot be seen by the naked eye. In addition, lead-contaminated dust is difficult to clean up. Leaded-dust is generated as lead-based paint deteriorates over time, is damaged by moisture, abraded on friction and impact surfaces, or disturbed in the course of renovation, repair, or abatement projects. Lead can also be tracked into homes from exterior dust and soil. Since Congress also defined lead found in dust and soil to be lead-based paint hazards, these *Guidelines* address lead in surface dust and soil as well as in paint.

### 4. Lead in Soil

Children can also be exposed to lead in bare soil. HUD estimates that almost 5 million housing units have levels of lead in soil that exceed EPA standards (Jacobs, 2002). The high levels of lead in soil typically come from deteriorating exterior lead-based paint around the foundation of a house (Ter Harr, 1974; Linton, 1980). The fallout of lead emissions from the combustion of leaded-automobile gasoline, lead-based paint, and industrial sources also contributes to lead levels in soil (ATSDR, 1988). In some areas high leaded-soil levels result from factory and smelter emissions or deteriorating lead-based paint on steel structures, such as bridges. Bare soil that is contaminated with lead poses a hazard to children who play in it. Lead in soil may also be tracked into a home, increasing interior levels of dust lead. These *Guidelines* address lead-contaminated soil, as well as lead-based paint and lead-contaminated dust.

## 5. Other Causes of Lead Poisoning

Other sources and pathways of lead poisoning in children can include drinking water, point sources (such as smelters or industrial dischargers), ceramics, toys, children's jewelry, lead brought home from a parent's workplace, imported candy and its candy wrappers, home and folk remedies, cosmetics, and hobbies (such as casting lead sinkers or toy soldiers, making stained glass, loading ammunition, and soldering). These sources may account for some children's exposure; however, for most children, paint, dust, and soil are the primary sources of lead poisoning. For additional and more recent information, go to CPSC home page, <http://www.cpsc.gov/>, look on that home page for recent news and click on "CPSC Publications." You may then click on "Find Publications by Specific Topic" to search for Lead and/or for Lead-based paint. If you click on the Spanish header to the CPSC Publications page, you may search for "plomo" in "Publicaciones en Español." You may also visit the CDC Lead Poisoning Prevention Program home page: <http://www.cdc.gov/nceh/lead/>.

## C. The Evolution of Prevention Approaches

The approach to identifying and responding to lead-based paint hazards and how they poison children in American housing has evolved over the past several decades.

### 1. Medical Treatment of Poisoned Children (Tertiary Treatment)

During the 1940s and 1950s, deaths from childhood lead poisoning were common. Using chelation therapy (the use of drugs to excrete lead from the body), medical providers attempted to treat symptomatic cases to prevent death, with the assumption that children who survived had been cured. During the 1950s, studies in Chicago (Williams, 1952), New York City (McLaughlin, 1956), and Baltimore (Chisolm, 1956) demonstrated conclusively that children who survived serious lead poisoning were often left mentally retarded or otherwise permanently impaired (Lin-Fu, 1982). More recent chelating agents are D-penicillamine and succimer (WebMD, 2010 at <http://emedicine.medscape.com/article/815399-treatment>). Chelation therapy should only be undertaken in consultation with a medical doctor with experience in the chelation of children for lead poisoning.

### 2. Screening and Case Management Programs (Secondary Prevention)

Recognition of these neurological problems gave rise to expanded screening and case management programs in many cities and states. Before the late 1980's, the traditional approach to childhood lead poisoning prevention was reactive, relying on the identification of a poisoned child to trigger investigation of lead hazards in the home environment. Based on the belief that children had to eat lead-based paint chips to be poisoned, the typical response to a lead poisoning during the 1970s and early 1980s consisted of removing deteriorated lead-based paint by scraping, uncontrolled sanding, or open flame burning. Approaches differed slightly, depending on the jurisdiction. Some jurisdictions required removal of all lead-based paint below a certain height, such as 5 feet; others required only that deteriorating paint be removed. However, these traditional abatements had one common characteristic: little attention was paid to controlling, containing, and cleaning up leaded-dust. In many cases these paint removal methods actually aggravated the problem and increased lead exposures,

poisoning workers and children in the process. Several studies found that uncontrolled abatement and inadequate cleanup caused increased blood-lead levels (Farfel and Chisolm, 1990; Rabinowitz, 1985a; Amitai, 1987).

### 3. Primary Prevention

As knowledge about lead poisoning increased, Congress concluded that responding to poisoned children was an ineffective solution to the nationwide problem. Legislation reflected a shift toward primary prevention. During the 1980s, HUD's requirements regarding treatment of lead-based paint were similarly amended. Department-wide regulatory revisions pertaining to lead-based paint in certain programs were made in 1986, 1987 and 1988. Housing and community development regulations began to include primary prevention strategies such as requiring inspections of pre-1978 public housing and abatement during substantial rehabilitation. HUD's 1990 *Interim Guidelines for Hazard Identification and Abatement in Public and Indian Housing (Interim Guidelines)*, which evolved from the 1987 Housing and Community Development Act, emphasized the danger of lead-contaminated dust and the need for worker protection and thorough cleanup. HUD's Office of Public and Indian Housing revised its program provisions in 1991, and made important changes in 1995 to the Housing Quality Standards (HQS), which apply to Section 8 tenant-based rental assistance and certain other HUD programs. When Title X was signed in 1992, primary prevention was included in the national strategy. The first edition of the final *Guidelines* was issued in 1995 and, as a documented methodology, has been incorporated by reference into many states' lead laws. The data demonstrating that no "safe" threshold for blood lead levels in young children has been identified highlights the importance of preventing childhood exposures to lead. It confirms the need for a systematic and society-wide effort to control or eliminate lead hazards in children's environments before they are exposed. In 2005, CDC specifically focused on primary prevention and published *Preventing Lead Poisoning in Young Children* (CDC, 2005).

## III. The Title X Regulatory Framework

Title X fundamentally reorganized the national approach to controlling lead-based paint hazards in housing by focusing attention on lead hazards through the establishment of new requirements for property owners as well as Federal agencies and mandating action to improve the safety and effectiveness of lead-based paint activities.

### A. Definition of "Lead-Based Paint Hazard"

Title X redefined the concept of "lead-based paint hazards." Under earlier Federal legislation (Housing and Community Development Act of 1987; Public Law 100-242), a lead-based paint hazard was defined as any paint containing 1 mg/cm<sup>2</sup> or more of lead regardless of its condition or location. Title X states that a lead-based paint hazard is "any condition that causes *exposure* to lead from lead-contaminated dust, lead-contaminated soil, or lead-contaminated paint that is deteriorated or present in accessible surfaces, friction surfaces, or impact surfaces that would result in adverse human health effects..." (emphasis added, 42 U.S.C. 4851 b(15)). Thus, under this definition, intact lead-based paint on most walls and ceilings is not considered a "hazard," although the condition of the paint should be monitored and maintained to ensure that it does not deteriorate. While most efforts to reduce lead hazards in housing will now be aimed at controlling lead-based paint hazards as defined by Title X,

Federal law makes one notable exception: in public housing and Tribally-Designated Housing Entities, all lead-based paint must be abated when the housing is modernized.

## B. Regulatory Framework for Lead Hazard Control

As directed by the Congress in Title X, HUD, EPA, OSHA, and CDC have issued the following regulations and guidelines with respect to the evaluation and control of lead-based paint hazards in housing (Refer to Appendix 6):

- ◆ HUD and EPA jointly: Requirements for Disclosure of Known Lead-Based Paint and/or Lead-Based Paint Hazards Upon Sale or Lease of Residential Property (HUD: 24 CFR Part 35, subpart A; EPA: 40 CFR Part 745, subpart F).
- ◆ HUD: Requirements for Notification, Evaluation and Reduction of Lead-Based Paint Hazards in Federally Owned Residential Property and Housing Receiving Federal Assistance, known as the HUD Lead Safe Housing Rule (24 CFR Part 35, subparts B-R).
- ◆ EPA: Requirements for Lead-Based Paint Activities in Target Housing and Child Occupied Facilities; Requirements for Hazard Education Before Renovation of Target Housing; Identification of Dangerous Levels of Lead; Renovation, Repair, and Painting. (40 CFR Part 745).
- ◆ OSHA: Interim Lead in Construction Standard (29 CFR 1926.62).
- ◆ CDC: CDC Response to Advisory Committee on Childhood Lead Poisoning Prevention Recommendations in “Low Level Lead Exposure Harms Children: A Renewed Call of Primary Prevention.” (CDC, 2012a). Preventing Lead Poisoning in Young Children (CDC, 2005); Managing Elevated Blood Lead Levels Among Young Children (CDC, 2002); and Screening Young Children for Lead poisoning: Guidance for State and Local Public Health Officials (CDC, 1997).

These regulations and guidelines constitute the Federal regulatory framework for the evaluation and control of lead-based paint hazards in housing, as of the publication of this second edition of the *Guidelines*. Future regulations, including revisions of existing regulations, are possible; the agencies’ websites should be checked for regulatory updates.

There are three Federal government initiatives that may affect the way lead-based paint issues are defined and dealt with in the future. In January 2012, an advisory committee to the CDC recommended that CDC no longer use the term “level of concern”, but use a childhood blood lead level reference value of 5 µg/dL, with possible future reductions (CDC ACCLPP, 2012); CDC considered the committee’s recommendations in formulating its policies, which it published on May 16, 2012 (CDC, 2012a). CDC adopted the core recommendation of eliminating the term “level of concern” from its future policies, guidance documents, and other CDC publications, and it will use a childhood blood lead level (BLL) reference value based on the 97.5th percentile of the population BLL in children ages 1-5 (5 µg/dL as of the publication of this edition of these *Guidelines*) to identify children and environments associated with lead-exposure hazards. CDC also adopted the recommendation that the reference value should be updated by CDC every four years based on the most recent population based blood lead surveys among children. CDC’s response to the other recommendations is provided in their full response. At the same time, CDC also issued Fact Sheet: Blood Lead Levels in Children – Important Information for Parents, providing parents and other concerned individuals with an update on this issue (CDC, 2012b). documents.

## 1. Evaluating Lead Hazards

The principal lead hazard evaluation methods are 1) risk assessment or lead hazard screen, 2) risk assessment combined with lead-based paint inspection, and 3) lead-based paint inspection combined with visual assessment (see *Figure 1.4*). Alternatives to evaluation include visual assessment and the presumption that lead-based paint and/or lead-based paint hazards are present.

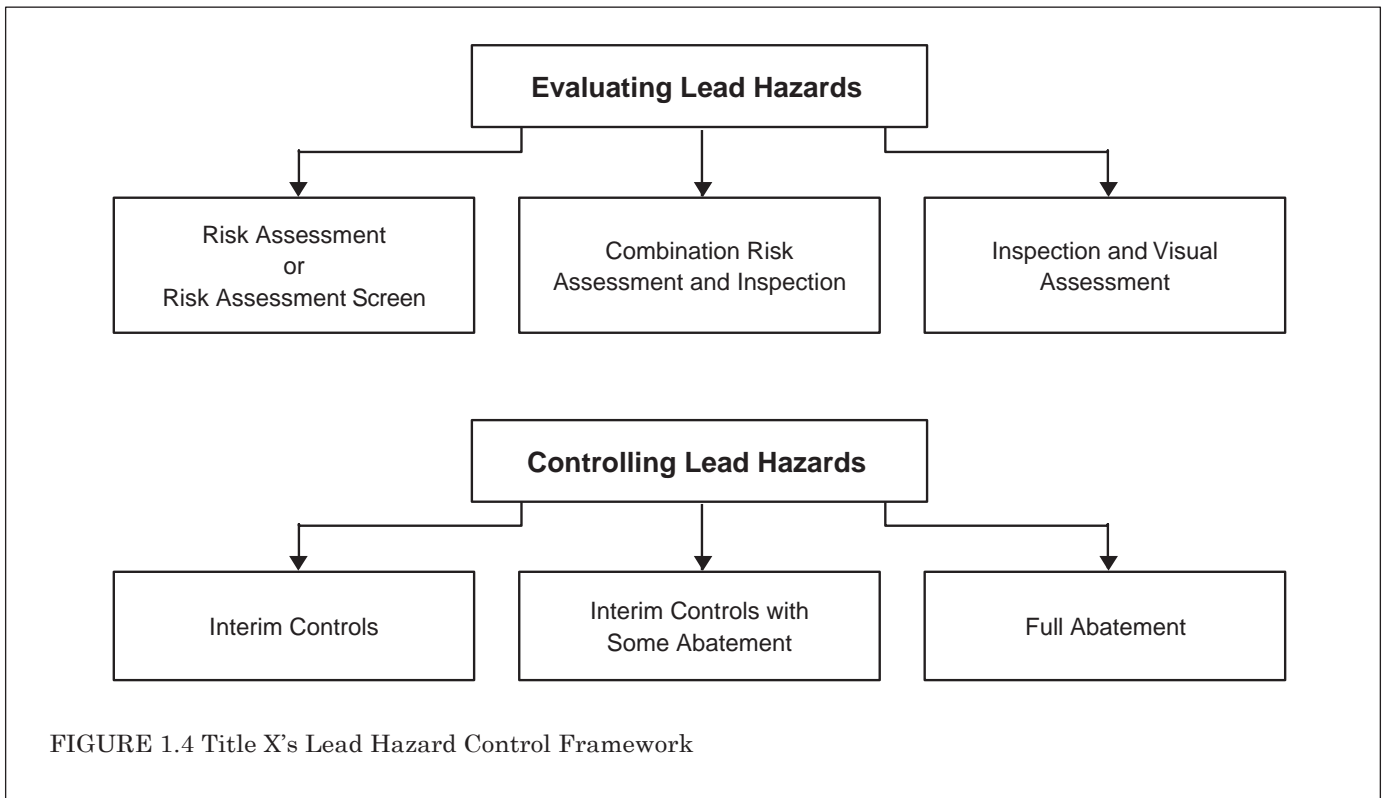

**“Risk assessment”** is an onsite investigation of a residential building for lead-based paint hazards and includes, but may not be limited to: a visual inspection; targeted environmental sampling of dust, soil, and deteriorated paint; and a report of the results that identifies acceptable abatement and interim control strategies for controlling any identified lead-based paint hazards. Risk assessments and paint inspections can be combined to provide a more comprehensive evaluation of lead hazards (see Chapters 3, 5 and 7).

**“Lead hazard screen”** is a limited assessment of hazards performed in accordance with the methods and standards made by the state or EPA, as appropriate. A lead hazard screen may identify the need for a follow-up risk assessment.

**“Paint inspection”** is a surface-by-surface investigation of all painted surfaces – interior and exterior – in common areas of multi-family buildings, as well as in dwelling units. The inspection uses portable X-ray fluorescent (XRF) analyzers and/or laboratory analysis of paint samples to determine the presence of lead-based paint, and provides a report of the results. Inspections to identify the presence of lead-based paint should not be confused with clearance examinations, risk assessments, or investigations of homes with lead-poisoned children. Adding a visual assessment will identify the presence of deteriorated paint that is a hazard.

“**Visual Assessment**” alone is an alternative to evaluation. Under some circumstances, such as for dwelling units occupied by families with tenant-based rental assistance or as part of ongoing lead-based paint maintenance, property owners or housing quality inspectors may conduct a visual assessment to identify any deteriorated paint, unusual amounts of visible dust, or other conditions that suggest the possible existence of lead hazards. HUD does not consider a visual assessment by itself to constitute an “evaluation” because it does not include a scientific test for the presence of lead. Nevertheless, a visual assessment that is combined with a lead-based paint inspection can identify the presence of lead-based paint hazards.

“**Presumption**” is another alternative to evaluation. Property owners may presume that all painted surfaces are coated with lead-based paint and that all bare soil is hazardous, so long as they treat all surfaces to be disturbed as if they contain lead. Such a presumptive approach may be cost-effective in the case of pre-1960 housing in poor condition. Presumption is specifically included in the Lead Safe Housing Rule.

## 2. Controlling Lead Hazards

Title X provides for three types of lead hazard control: interim controls; abatement of lead-based paint hazards; and complete abatement of all lead-based paint (see Figure 1.4). Interim control and abatement activities are frequently combined in lead hazard control projects. Other construction activities, such as renovation and remodeling, rehabilitation, and weatherization, also may treat some or all lead hazards. These *Guidelines* recommend procedures that increase the safety and effectiveness of all types of construction projects that are carried out in housing that might contain lead-based paint, regardless of the intent.

The three types of lead hazard control are described as follows:

**Interim controls**, according to Title X, are “a set of measures designed to reduce temporarily human exposure or likely exposure to lead-based paint hazards, including specialized cleaning, repairs, maintenance, painting, temporary containment, ongoing monitoring of lead-based paint hazards or potential hazards, and the establishment and operation of management and resident education programs.” Interim controls include cleaning surfaces of dust, paint film stabilization and friction and impact surface treatments. Interim controls are appropriate for implementation on a broad scale. Research has found them to be cost-effective in many cases (NCHH, 2004). Whenever interim controls are employed, the property owner should undertake ongoing maintenance of lead-based paint, as some potential hazards may still be present and new hazards may be created. Interim controls are essentially renovation and repair items, and fall under the EPA’s RRP rule.

**Abatement of lead-based paint hazards**, according to Title X, is “a set of measures designed to permanently eliminate lead-based paint hazards....” Such measures include: “(A) the removal of lead-based paint and lead-contaminated dust, the permanent containment or encapsulation of lead-based paint, the replacement of lead painted surfaces or fixtures, and the removal or covering of lead-contaminated soil; and (B) all preparation, cleanup, disposal, and post-abatement clearance testing activities associated with such measures.” Title X redefined the term “abatement” to mean the elimination of “lead-based paint hazards” to last for a period of twenty years, not necessarily removal of all lead-based paint.

**Full abatement of lead-based paint is where** all lead-based paint has been abated and clearance has been achieved. When paint removal is the abatement method used, the property has achieved the status of “lead-based paint free.” This can exempt the property from the Lead Safe Housing Rule, although disclosure of knowledge is still necessary for sale of target housing. If hazards are abated by encapsulation or enclosure, lead-based paint on the property would remain, and the property would not be “lead-based paint free.”

## **C. Requirements To Ensure Quality Control**

To ensure that lead hazard control work is carried out safely and effectively, Title X imposed a number of requirements for consistency and quality control.

### **1. Training and Certification**

EPA requires that all risk assessors, lead-based paint inspectors, dust sampling technicians, abatement supervisors, abatement workers, and renovation supervisors (“certified renovators”), who receive compensation for their work in target housing or pre-1978 child-occupied facilities that is not exempt from the applicable regulations, meet minimum training requirements and be certified by EPA or by an EPA-authorized State or Tribal program (40 CFR §§ 745.227 or 745.324). Workers on federally assisted abatement, interim control, maintenance or rehabilitation projects in target housing must meet HUD-approved training requirements (24 CFR §§ 35.1325 or 35.1330); since the EPA’s Renovation, Repair, and Painting (RRP) Rule went into effect in 2010, HUD’s lead-safe work practices training requirement is satisfied by EPA’s renovation certification training requirement. Technicians who collect dust samples in connection with clearance examinations (sampling technicians) after renovation and rehabilitation (but not abatement) must meet EPA and, if applicable, HUD training requirements (40 CFR 745.90 and 24 CFR 35.1340). Training is generally not provided by EPA or HUD, but is provided by the private sector and some state, local, and tribal governments.

### **2. Accreditation of Training Providers**

EPA requires that every training program delivering courses for lead certification for activities in target housing and pre-1978 child-occupied facilities be accredited by either EPA or an EPA-authorized State or Tribal certification program.

### **3. Health-Based Standards**

EPA has identified standards for dangerous levels of lead in household dust, soil, and paint, as set forth in section IV.C of this chapter, for use in risk assessments and for clearance after completion of lead hazard control activities.

### **4. Performance Standards for Testing and Abatement Products**

HUD and EPA have established criteria, testing protocols, and performance standards checklists for lead-based paint evaluation and hazard reduction products. The American Society for Testing and Materials has also developed a number of such standards. Those criteria, protocols, performance characteristics and standards are reflected in these *Guidelines*.

## 5. Laboratory Accreditation

Laboratories analyzing environmental samples of lead in paint film, dust, and soil must be recognized by EPA under the National Lead Laboratory Accreditation Program (NLLAP). A state-by-state list of NLLAP-recognized laboratories is provided on the Internet at <http://www.epa.gov/lead/pubs/nllaplist.pdf>.

## D. State and Local Regulations

Many States and some local governments have issued regulations governing lead hazard evaluation and control. If there is a difference between Federal, State and local regulations, the more stringent applicable requirements must be observed in any given jurisdiction.

# IV. Organization and Use of the Guidelines

Evaluation and control of lead-based paint hazards is an evolving field. For cases in which research has demonstrated that certain techniques are appropriate, references are cited. In some cases, laws or regulations specify how something is to be done; in other cases, no or an insufficient amount of research has been done to describe clearly the best approach to solving a specific problem. Recognizing that problems require answers, these *Guidelines* offer advice based on the experience and considered judgment of the authors and reviewers, and on the applicable laws and regulations. For cases in which citations are not provided, the reader should assume that the source of the advice is anecdotal and is the best advice that HUD can provide at this time.

## A. Chapter Organization

A short summary of steps is provided at the beginning of each technical chapter to alert the reader to especially critical points and action steps. In general, the material is presented in each chapter in order of sequence in a typical project; however, a complete reading and understanding of these *Guidelines* is essential before any project is undertaken. Wherever possible, the *Guidelines* explain the rationale for recommendations and provide a technical description of the action to be taken.

### 1. Chapters 1-4: Background Information

Understanding the background material is critical to the successful completion of any project.

**Chapter 1, *Introduction***, describes the purpose and application of the *Guidelines*; briefly reviews the hazards of lead-based paint in housing; summarizes major departures from past approaches; and provides context in terms of Federal law, regulations, and agency programs.

**Chapter 2, *Where To Go for Help-Qualifications and Roles***, introduces the types of individuals involved in evaluating and controlling lead-based paint hazards in housing, explains their roles, and summarizes their qualifications.

**Chapter 3, *Before You Begin the Project-Planning to Control Lead Hazards***, identifies the critical issues that must be examined to avoid problems and mistakes that can result in project delays and cost overruns.

**Chapter 4, *Lead-Based Paint and Housing Renovation***, provides general advice on how to carry out work in older housing so that lead hazards are not inadvertently created (e.g., by disturbing lead-based paint) and how to combine renovation with abatement work.

## 2. Chapters 5-7: Hazard Evaluation and Ongoing Maintenance

Hazard evaluation helps ensure the selection of the safest and most cost-effective hazard control strategy for each situation.

**Chapter 5, *Risk Assessment and Reevaluation***, provides detailed guidance on how risk assessments are to be conducted in various categories of housing, including protocols for environmental sample collection and interpretation, evaluation of building and paint condition, and methods for sampling a subset of units in multi-family buildings.

**Chapter 6, *Ongoing Lead-Safe Maintenance***, provides detail on how to properly manage remaining lead-based painted components and soil with elevated levels of lead into the future while minimizing risk. This chapter incorporates much of the contents of Chapter 17, *Routine Building Maintenance and Lead-Based Paint*, of the first edition of these *Guidelines*.

**Chapter 7, *Lead-Based Paint Inspection***, provides detailed information on methods for testing housing to determine the presence of lead-based paint on a surface-by-surface basis, including the use of portable XRF analyzers and paint-chip sampling for laboratory analysis.

## 3. Chapters 8-10: Preparation for the Project

The critical steps in preparing to control lead-based paint hazards are covered in Chapters 8-10.

**Chapter 8, *Resident Protection and Worksite Preparation***, provides guidance on the steps needed to ensure that occupants are not endangered and that contamination is not spread.

**Chapter 9, *Worker Protection***, provides detailed advice on how to comply with the OSHA Lead in Construction Standard while performing work in housing.

**Chapter 10, *Housing Waste***, provides practical advice on methods for handling and disposing various kinds of debris to protect the environment.

## 4. Chapters 11-15: Hazard Control, Cleanup, and Clearance

Detailed information on how to carry out all aspects of lead hazard control is provided in Chapters 11-15.

**Chapter 11, *Interim Controls***, provides specific guidance on interim controls: general principles of interim controls; dust removal; paint film stabilization; friction surface treatments; and soil and exterior dust treatments. The chapter also incorporates some of the contents of Chapter 17 of the first edition of these *Guidelines*.

**Chapter 12, *Abatement***, covers general principles of abatement such as component replacement, enclosure, paint removal methods, and soil abatement.

**Chapter 13, *Encapsulation***, describes how to use encapsulants.

**Chapter 14, *Cleaning Following Hazard Controls or other Paint-Disturbing Work***, details cleanup procedures for lead hazard control projects.

**Chapter 15, *Clearance***, explains how to conduct clearance tests after a lead hazard control project to ensure that a unit or area is safe for reoccupancy.

## 5. Chapters 16-18: Related Issues

Information on addressing lead-based paint hazards in special situations is provided in the final chapters of these *Guidelines*.

**Chapter 16, *Investigation and Treatment of Dwellings that House Children with Elevated Blood Lead Levels***, describes the special measures that are usually taken by health departments, property owners and others to investigate and treat environmental lead hazards once a child has been identified as having an elevated blood lead level.

The substance of **Chapter 17, *Routine Building Maintenance and Lead-Based Paint***, was incorporated into the revised Chapters 6 and 11. Chapter 17 is now reserved for potential future use.

**Chapter 18, *Historic Preservation***, discusses the special situations and issues surrounding lead-based paint in historic dwellings.

## 6. Glossary and Appendices

The definitions of key terms are consolidated in the glossary and deserve special attention because the meanings of several key terms, such as “abatement” and “renovation,” differ from common usage. The appendices provide detailed background information and technical materials.

### B. Units of Measurement

- ◆ **mg/cm<sup>2</sup>** – milligrams per square centimeter, used for paint.
- ◆ **mg/L** – milligrams per liter, used for water.
- ◆ **percent** – percent by weight, primarily used for paint (1 percent = 10,000 µg/g).
- ◆ **ppb** – parts per billion by weight (1,000 ppb = 1 ppm); primarily used for water.
- ◆ **ppm** – parts per million by weight (10,000 ppm = 1 percent), equivalent to µg/g; primarily used for paint and soil.
- ◆ **µg/dL** – micrograms per deciliter, used for blood.
- ◆ **µg/ft<sup>2</sup>** – micrograms per square foot, used for settled dust.
- ◆ **µg/g** – micrograms per gram of sample, equivalent to ppm by weight; primarily used for paint and soil.
- ◆ **µg/m<sup>3</sup>** – micrograms per cubic meter, used for air.

### C. Federal Lead Standards

If Federal standards differ from State, Tribal or local standards, the most stringent (protective) standards must be applied.

- ◆ Lead-based paint – 24 CFR 35.110 and 40 CFR 745.103  
1 mg/cm<sup>2</sup> or 5,000 µg/g (5,000 ppm, equal to 0.5 percent).
- ◆ Paint containing lead applied between 1978 and August 13, 2009  
0.06 percent (600 ppm) by weight.
- ◆ Paint containing lead applied on or after August 14, 2009 – 16 CFR 1303.2  
0.009 percent (90 ppm) by weight.
- ◆ Dust lead hazard levels (by wipe sampling) – 40 CFR 745.65(b)  
40 µg/ft<sup>2</sup> – floors (carpeted and uncarpeted).  
250 µg/ft<sup>2</sup> – interior windowsills.
- ◆ Dust lead levels for lead hazard screen only (by wipe sampling) – 24 CFR 35.1320(b)(2)(i)  
25 µg/ft<sup>2</sup> – floors.  
125 µg/ft<sup>2</sup> – interior windowsills.
- ◆ Dust lead clearance levels (by wipe sampling) – 40 CFR 745.227(e)(8)(viii)  
40 µg/ft<sup>2</sup> – floors (includes carpeted and uncarpeted interior floors).  
250 µg/ft<sup>2</sup> – interior windowsills.  
400 µg/ft<sup>2</sup> – window troughs (previously called “window wells” in some literature).
- ◆ Bare residential soil hazard levels – 40 CFR 745.65(c)  
400 µg/g – play areas used by young children.  
1,200 µg/g – building perimeter (dripline or foundation area) and yard other than play areas.
- ◆ Airborne lead particulate – Occupational Exposure Criteria  
30 µg/m<sup>3</sup> – OSHA action level (8-hour time-weighted average) – 29 CFR 1926.62(b)  
50 µg/m<sup>3</sup> – OSHA permissible exposure limit (8-hour time-weighted average) – 29 CFR 1926.62(c)(1)
- ◆ National Primary and Secondary Ambient Air Quality Standard for Lead – 40 CFR 50.16(a)  
0.15 µg/m<sup>3</sup> – arithmetic mean concentration averaged over a 3-month period.
- ◆ Lead action level for drinking water systems – 40 CFR 141.80(c)(1)  
15 ppb (0.015 mg/L) – Exceeded if lead is above this concentration in over 10% of a drinking water system’s tap water samples.

# References

- AAP, 1993. American Academy of Pediatrics, Committee on Environmental Health. Lead Poisoning From Screening to Primary Prevention, Statement on Childhood Lead Poisoning, RE 9307.
- Amitai, 1987. Amitai, Y., J.W. Graef, M.J. Brown, R.S. Gerstle, N. Kahn, and P.E. Cochrane. "Hazards Of 'Deleading' Homes Of Children With Poisoning," *American Journal of Diseases of Children* 141: 758–760.
- ATSDR, 1988. Agency for Toxic Substances and Disease Registry, U.S. Department of Health and Human Services, *The Nature and Extent of Lead Poisoning in Children in the United States: A Report to Congress*, Atlanta, Georgia. <http://www.cdc.gov/mmwr/preview/mmwrhtml/00001077.htm>
- Bellinger, 1991. Bellinger D., J. Sloman, A. Leviton, M. Rabinowitz, H. Needleman, and C. Waternaux, "Low Level Lead Exposure and Children's Cognitive Function in the Preschool Years," *Pediatrics* 87: 219227.
- Bellinger, 2006. D. C. and A. M. Bellinger, "Childhood lead poisoning: The torturous path from science to policy," *Journal of Clinical Investigation*, 116: 853-857. doi: 10.117/JCI28232. <http://www.jci.org/articles/view/28232/pdf>
- CDC, 1991a. Centers for Disease Control, U.S. Department of Health and Human Services. *Preventing Lead Poisoning in Young Children: A Statement by the Centers for Disease Control*. 4th revision. Atlanta, Georgia. <http://wonder.cdc.gov/wonder/prevguid/p0000029/p0000029.asp>
- CDC, 1991b. Centers for Disease Control, U.S. Department of Health and Human Services. *Strategic Plan for the Elimination of Childhood Lead Poisoning*, Atlanta, Georgia. <http://wonder.cdc.gov/wonder/prevguid/p0000029/p0000029.asp>
- CDC, 1997. Centers for Disease Control and Prevention, U.S. Department of Health and Human Services. *Screening Young Children for Lead Poisoning: Guidance for State and Local Public Health Officials*, Atlanta, Georgia. <http://www.cdc.gov/nceh/lead/publications/screening.htm>
- CDC, 2000. Centers for Disease Control and Prevention, U.S. Department of Health and Human Services. *Morbidity and Mortality Weekly Report*. "Blood Lead Levels in Young Children-United States and Selected States, 1996-1999," December 22, 2000 / 49(50);1133-7. <http://www.cdc.gov/mmwr/preview/mmwrhtml/mm4950a3.htm>
- CDC, 2002. Centers for Disease Control and Prevention, U.S. Department of Health and Human Services. *Managing Elevated Blood Lead Levels Among Young Children: Recommendations from the Advisory Committee on Childhood Lead Poisoning Prevention*. March 2002. [http://www.cdc.gov/nceh/lead/casemanagement/casemanage\\_main.htm](http://www.cdc.gov/nceh/lead/casemanagement/casemanage_main.htm)
- CDC, 2005. Centers for Disease Control and Prevention, U.S. Department of Health and Human Services, *Preventing Lead Poisoning in Young Children*. 5th revision. Atlanta, Georgia. Available at <http://www.cdc.gov/nceh/lead/publications/prevleadpoisoning.pdf>
- CDC, 2007. *Interpreting and Managing Blood Lead Levels < 10 µg/dL in Children and Reducing Childhood Exposures to Lead: Recommendations of the CDC's Advisory Committee on Lead Poisoning Prevention*. MMWR. Recommendations and Reports November 2, 2007;56.

CDC ACCLPP, 2012. CDC Advisory Committee on Childhood Lead Poisoning Prevention. Low Level Lead Exposure Harms Children: A Renewed Call for Primary Prevention. Report of the Advisory Committee on Childhood Lead Poisoning Prevention of the Centers for Disease Control and Prevention. [http://www.cdc.gov/nceh/lead/ACCLPP/Final\\_Document\\_030712.pdf](http://www.cdc.gov/nceh/lead/ACCLPP/Final_Document_030712.pdf)

CDC, 2012a. CDC Response to Advisory Committee on Childhood Lead Poisoning Prevention Recommendations in “Low Level Lead Exposure Harms Children: A Renewed Call of Primary Prevention.” June 7, 2012. [http://www.cdc.gov/nceh/lead/ACCLPP/CDC\\_Response\\_Lead\\_Exposure\\_Recs.pdf](http://www.cdc.gov/nceh/lead/ACCLPP/CDC_Response_Lead_Exposure_Recs.pdf).

CDC, 2012b. Fact Sheet: Blood Lead Levels in Children – Important Information for Parents. [http://www.cdc.gov/nceh/lead/ACCLPP/Lead\\_Levels\\_in\\_Children\\_Fact\\_Sheet.pdf](http://www.cdc.gov/nceh/lead/ACCLPP/Lead_Levels_in_Children_Fact_Sheet.pdf)

Chisolm, 1956. Chisolm, J.J., and H.E. Harrison, “The Exposure of Children to Lead,” *Pediatrics* 18: 943-958.

Chisolm, 1985. Chisolm, J.J., E.D. Mellits, and S.A. Quaskey, “The Relationship Between the Level of Lead Absorption in Children and the Age, Type, and Condition of Housing,” *Environmental Research* 38: 31–45.

Clark, 1991. Clark, C.S., R. Bornschein, P. Succop, S. Roda, and B. Peace, “Urban Lead Exposures of Children in Cincinnati, Ohio,” *Journal of Chemical Speciation and Bioavailability*, 3(3/4): 163–171.

CPSC, 2008. Consumer Product Safety Commission. “Ban of Lead-Containing Paint and Certain Consumer Products Bearing Lead-Containing Paint.” 73 Federal Register 77492-77493; December 19, 2008. Download via <http://origin.www.gpoaccess.gov/fr/>.

CMS, 9/98. Department of Health and Human Services Health Care Financing Administration (now Centers for Medicare & Medicaid Services). “Early and Periodic Screening, Diagnosis, and Treatment (EPSDT): Lead Toxicity Screening.” HCFA Pub. 45-5.

Davis, 1993. Davis, J.M., Elias, R.W., Grant, L.D., “Current Issues in Human Lead Exposure and Regulation of Lead,” *NeuroToxicology* 14(2–3): 1528.

Farfel, 1994a. Farfel, M., Briefing at EPA headquarters, Washington, DC, February 1994.

Farfel and Chisolm, 1990. Farfel, M., and J.J. Chisolm, Jr., “Health and Environmental Outcomes of Traditional and Modified Practices for Abatement of Residential Lead-Based Paint,” *American Journal of Public Health* 80: 10, 1240–1245.

HUD/EPA letter, 2001. Sanders, W.H., and D.E. Jacobs, public letter signed jointly by the U.S. Environmental Protection Agency and the U.S. Department of Housing and Urban Development to clarify Federal requirements for rehabilitation and lead hazard reduction in property receiving up to \$25,000 in Federal rehabilitation assistance, April 19, 2001. [http://portal.hud.gov/hudportal/documents/huddoc?id=DOC\\_25480.pdf](http://portal.hud.gov/hudportal/documents/huddoc?id=DOC_25480.pdf)

Jacobs, 1994. Jacobs, D.E., *Lead-Based Paint Abatement at Murphy Homes*, Georgia Tech Research Institute report, unpublished.

Jacobs, 2002. Jacobs, D.E., R.P. Clickner, J.Y. Zhou, S.M. Viet, D.A. Marker, J.W. Rogers, D.C. Zeldin, P. Broene and W. Friedman, “The Prevalence of Lead-Based Paint Hazards in US Housing,” *Environmental Health Perspectives*, 110(10): 599, October 2002. <http://ehp03.niehs.nih.gov/article/action?articleURI=info%3Adoi%2F10.1289%2Fehp.021100599>

Jones, 2009. Jones R, Homa D, Meyer P, Brody D, Caldwell K Pirkle J, Brown MJ. Trends in blood lead levels and blood lead testing among U. S. children aged 1 to 5 years: 1998-2004. *Pediatrics* 2009;123:e376-e385

Lanphear, 1998. Lanphear B.P., T.D. Matte, J. Rogers, R.P. Clickner, B. Dietz, R.L. Bornschein, P.Succop, K.R. Mahaffey, S. Dixon, W. Galke, M. Rabinowitz, M. Farfel, C. Rohde, J. Schwartz, P. Ashley, D.E. Jacobs. "The Contribution of Lead-Contaminated House Dust and Residential Soil to Children's Blood Lead Levels: A Pooled Analysis of 12 Epidemiological Studies," *Environmental Research* 79: 5168.

Lin-Fu, 1982. Lin-Fu, J., "Children and Lead, New Findings and Concerns," *New England Journal of Medicine* 307: 615-617.

Linton, 1980. Linton, R.W., D.F.S. Natush, R.L. Solomon, C.A. Evans, "Physicochemical Characterization of Lead in Urban Dusts: A Microanalytical Technique to Lead Tracing," *Environmental Science Technology* 14: 159-164.

Markowitz, 2000. G. Markowitz and D. Rosner, "Cater to the Children: The role of the Lead Industry in a Public Health Tragedy, 1900-1955, *Am. J. Public Health*, 90: 36-46. <http://www.mindfully.org/Health/Lead-Industry-Public-Health.htm>

McLaughlin, 1956. McLaughlin, "Lead Poisoning in Children in New York City, 1940-1954," *New York State Medical Journal* 56: 3711-3714.

National Academy of Sciences, 1993. *Measuring Lead Exposure in Infants, Children, and Other Sensitive Populations*, Committee on Measuring Lead in Critical Populations, Board on Environmental Studies and Toxicology, Commission on Life Sciences, National Academy Press, Washington, DC.

NCHH, 2004. National Center for Healthy Housing, and University of Cincinnati Department of Environmental Health, *Evaluation of the HUD Lead-Based Paint Hazard Control Grant Program: Final Report*, prepared for the U.S. Department of Housing and Urban Development, Washington, DC, May 1, 2004.

New York Times, 1971. Bird, D., "High Lead Paints Listed by City," *New York Times*, August 4, 1971: 18.

Rabin, 1989. Rabin, R., "Warnings Unheeded: A History of Lead Poisoning," *American Journal of Public Health* 79: 1668-1674. <http://ajph.aphapublications.org/cgi/reprint/79/12/1668>

Rabinowitz, 1985a. Rabinowitz, M., A. Leviton, and D. Bellinger, "Home Refinishing, Lead Paint, and Infant Blood Lead Levels," *American Journal of Public Health* 75(4): 403-404. <http://ajph.aphapublications.org/cgi/reprint/75/4/403.pdf>

Rabinowitz, 1985b. Rabinowitz, M., A. Leviton, H. Needleman, D. Bellinger, and C. Waternaux, "Environmental Correlates of Infant Blood Lead Levels in Boston," *Environmental Research* 38: 96-107.

Reich, 1992. Reich, P., *The Hour of Lead*, Environmental Defense Fund, Washington, DC.

Roberts, 1991. Roberts, J.W., D.E. Camann, and T.M. Spittler, "Reducing Lead Exposure From Remodeling and Soil Track-In in Older Homes," in *Proceedings of the Annual Meeting of Air and Waste Management Association*, Paper No. 91-134.2, Vancouver, British Columbia, Canada.

Schwemberger, 2005. J.G. Schwemberger, J.E. Mosby, M.J. Doa. D.E. Jacobs, P.J. Ashley, D.J. Brody, M.J. Brown, R.L. Jones, D. Homa, *Blood Lead Levels - United States, 1999-2002*, MMWR Weekly, 54(20);513-516, Atlanta, Georgia. Available at <http://www.cdc.gov/mmwr/preview/mmwrhtml/mm5420a5.htm>

Ter Har, 1974. Ter Har, G., and R. Aronow, "New Information on Lead in Dirt and Dust as Related to the Childhood Lead Problem," *Environmental Health Perspectives* 7 (May 1974): 83–89. <http://www.ncbi.nlm.nih.gov/pubmed/4831152>

Turner, 1897. Turner, J.A., "Lead Poisoning Among Queensland Children," *Australian Medical Gazette* 16: 475–479.

Warren, 2002/ C. Warren, "Old Paint: A Medical History of Childhood Lead-Paint Poisoning in the United States to 1980," *JAMA*, 287:916-917.

Williams, 1952. Williams, H., E. Kaplan, C.E. Couchman, and R.R. Sayres, "Lead Poisoning in Young Children," *Public Health Reports* 67: 230–236. <http://www.ncbi.nlm.nih.gov/pmc/articles/PMC2030733/pdf/pubhealthreporig01075-0010.pdf>

---

# Glossary

## Notes:

- ◆ These definitions are for use within the scope of these *Guidelines*, that is, for lead-based paint hazard evaluation and control, and are not necessarily generic definitions applicable outside of this scope.
- ◆ For Federal regulatory definitions, please see:
  - CPSC’s Lead-Containing Paint regulation (16 CFR 1303);
  - EPA’s Lead-Based Paint Abatement; Renovation, Repair and Painting; and Pre-Renovation Education regulations (40 CFR Part 745);
  - HUD’s Lead Disclosure Rule and Lead Safe Housing Rule (24 CFR Part 35); and
  - OSHA’s Lead in Construction standard (29 CFR 1926.62).

**AAALA:** American Association for Laboratory Accreditation. Also known as **A2LA**.

**Abatement:** A measure or set of measures designed to permanently eliminate lead-based paint hazards or lead-based paint. Abatement strategies include the removal of lead-based paint, enclosure, encapsulation, replacement of building components coated with lead-based paint, removal of lead-contaminated dust, and removal of lead-contaminated soil or overlaying of soil with a durable covering such as asphalt (grass and sod are considered interim control measures). All of these strategies require preparation; cleanup; waste disposal; post-abatement clearance testing; recordkeeping; and, if applicable, monitoring. (For full EPA definition, see 40 CFR 745.223). See, also, **Interim controls**.

**Abrasion resistance:** Resistance of the paint to wear by rubbing or friction; related to both toughness and gloss.

**Accreditation:** A formal recognition that an organization, such as a training provider, is competent to carry out specific tasks or types of tests.

**Accredited training provider:** A training provider who meets the standards established by EPA (or an EPA-authorized State or Tribe) for the training of risk assessors, inspectors, abatement supervisors, abatement workers, renovators, and dust sampling technicians.

**Accuracy:** The degree of agreement between an observed value and an accepted reference value (a “true” value); a data quality indicator. Accuracy includes a combination of random errors (precision) and systematic errors (bias) due to sampling and analysis. See also the related, but different, term **Precision**.

**Acrylic:** A synthetic resin used in high performance waterborne coatings; a coating whose binder contains acrylic resins.

**Adhesion:** The ability of dry paint or other coating to attach to a surface and remain fixed on it without blistering, flaking, cracking, or being susceptible to removal by tape.

**Administrative removal:** The temporary removal of workers from the job to prevent the concentration of lead in their blood from reaching levels requiring medical removal.

**AIHA:** American Industrial Hygiene Association.

**ALC:** see **Apparent Lead Concentration**.

**Aliquot:** see **Subsample**.

**Alkali:** A chemical, such as lye, soda, lime, etc., that will neutralize an acid. Oil paint films can be destroyed by alkalis. Some paint removal products contain alkaline substances.

**Alkyd:** Synthetic resin modified with oil; coating that contains alkyd resins in the binder.

**Apparent Lead Concentration (ALC):** The x-ray fluorescence (XRF) reading or average of more than one reading on a painted surface. See also **XRF analyzer**, **Substrate Equivalent Lead (SEL)**, and **Corrected Lead Concentration (CLC)**.

**Arithmetic mean:** Average.

**Bare soil:** Soil not covered with grass, sod, some other similar vegetation, or paving, including the sand in sandboxes.

**Bias:** A systematic error in the measurement process. For XRF readings, one source of bias is the substrate effect. See also **Substrate effect** and **XRF analyzer**.

**Binder:** Solid ingredients in a coating that hold the pigment particles in suspension and bind them to the substrate. Binders used in paints and coatings include oil, alkyd, acrylic, latex, and epoxy. The nature and amount of binder determines many of the coating's performance properties – wash ability, toughness, adhesion, gloss, etc. See, also, **Pigment**.

**Biological monitoring:** The analysis of blood, urine, or both to determine the level of lead contamination in the body. Blood lead levels are expressed in micrograms of lead per deciliter (one-tenth of a liter) of blood, or  $\mu\text{g/dL}$ . They are also expressed in micromoles per liter ( $\mu\text{mol/L}$ ).

**Blank:** An unexposed sample of the medium being used for testing (i.e., wipe or filter) that is analyzed to determine if the medium has been contaminated with lead (e.g., at the factory or during transport).

**Blind sample:** A sample submitted for analysis that has a known composition and identity that is not known to the analyst; used to test the analyst's or laboratory's proficiency in conducting measurements. See, also, the related term **Spiked sample**.

**Building component:** Any element of a building that may be painted or have dust on its surface, e.g., walls, stair treads, floors, railings, doors, windowsills, etc.

**Building component replacement:** see **Replacement**.

**Cementitious material:** A material that is mixed with water, either with or without aggregate, to provide the plasticity, cohesion, and adhesion necessary for the placement and formation of a rigid mass (ASTM Standard C 11).

**Centimeter:** see **cm**.

**Certification:** The process of testing and evaluating against certain specifications the competence of a person, organization, or other entity in performing a function or service, usually for a specified period of time.

**Certified:** The designation for contractors who have completed training and other requirements to allow them to safely undertake risk assessments, inspections, abatement or renovation. Risk assessors, inspectors, abatement contractors and renovation contractors should be certified (and licensed, if applicable) by the appropriate local, State or Federal agency.

**Certified Industrial Hygienist (CIH):** A person who has passed the 2-day certification exam of the American Board of Industrial Hygiene, and who has at least 4 years of experience in industrial hygiene and a graduate degree or a total of 5 years of experience. See, also, **Industrial hygienist**.

**Certified reference material (CRM):** Reference material that has at least one of its property values established by a technically valid procedure and is accompanied by or traceable to a certificate or other documentation issued by a certifying body. See, also, **Standard reference material**.

**Certified Renovator:** An individual who has successfully completed a renovator course accredited by EPA or an EPA-authorized State or Tribal program.

**CFR:** see **Code of Federal Regulations**.

**Chalking:** The photo-oxidation of paint binders - usually due to weathering - that causes a powder to form on the film surface.

**Chewable surface:** An interior or exterior surface painted with lead-based paint that a young child can mouth or chew. A chewable surface is the same as an “accessible surface” as defined in 42 U.S.C. 4851b(2). Hard metal substrates and other materials that cannot be dented by the bite of a young child are not considered chewable.

**Chewed surface:** Any painted surface that shows evidence of having been chewed or mouthed by a young child. A chewed surface is usually a protruding, horizontal part of a building, such as an interior windowsill. See, also, **Chewable surface**.

**CLC:** see **Corrected Lead Concentration (CLC)**

**Cleaning:** The process of using a vacuum and wet cleaning agents to remove leaded dust; the process includes the removal of bulk debris from the work area.

**Cleaning Verification:** The procedure required by EPA under its Renovation, Repair and Painting regulation after most renovations that disturb known or presumed lead-based paint. A certified renovator must perform a visual inspection to determine whether dust, debris or residue is still present. If so, these must be removed by re-cleaning and another visual inspection must be performed. After a successful visual inspection, the certified renovator must verify that each windowsill, uncarpeted floor and countertop in the work area has been adequately cleaned by wiping them with wet disposable cleaning cloths that are damp to the touch. If a cloth matches or is lighter than an EPA cleaning verification card, the surface passes; if not, it has to be re-cleaned and reverified. For more details, see Appendix 6 and 40 CFR 745.85(b).

**Clearance examination:** Visual examination and collection of lead dust samples by an inspector or risk assessor, or, in some circumstances, a sampling technician, and analysis by a EPA-recognized laboratory upon completion of an abatement project, interim control intervention, maintenance or renovation job that disturbs lead-based paint (or paint presumed to be lead-based.) For abatement projects, the clearance examination is performed to ensure that lead exposure levels do not exceed clearance standards established by the EPA at 40 CFR 745.227(e)(8)(viii); HUD’s dust-lead standards for clearance after interim control projects are found at 24 CFR 35.1320(b)(2)(i).

**Clearance examiner:** A person who conducts clearance examinations following lead-based paint hazard control and cleanup work, usually a certified risk assessor, certified inspector or sampling technician.

**cm:** Centimeter; 1/100 of a meter.

**Code of Federal Regulations (CFR):** The codification of the regulations of Federal agencies. The regulations are published in the *Federal Register*. See, also, *Federal Register (FR)*.

**Cohesion:** Ability of a substance to adhere to itself; internal adhesion; the force holding a substance together.

**Common area:** A room or area that is accessible to residents of more than one dwelling unit (e.g., hallways or lobbies); in general, any area not kept locked.

**Competent person:** As defined in the OSHA Lead Construction Standard (29 CFR 1926.62), a person who is capable of identifying or predicting hazardous working conditions and work areas, and who has authorization to take prompt, corrective measures to eliminate the hazards. A competent person may also be a risk assessor, inspector, abatement project supervisor or certified renovator; however, certification on its own does not give a person the authority to take corrective action, which a competent person must have.

**Compliance plan:** A document that describes the types of tasks, workers, protective measures, and tools and other materials that may be employed in lead-based paint hazard control to comply with the OSHA Lead Exposure in Construction standard.

**Composite sample:** A single sample made up of individual subsamples. Analysis of a composite sample produces the arithmetic mean of all subsamples.

**Construction and Demolition Landfill (C&D):** Landfills that only accept waste from construction and demolition activities. Some states and local governments permit residential LBP waste to be accepted as well.

**Containment:** A process to protect workers and the environment by controlling exposures to the lead-contaminated dust and debris created during abatement, interim controls or lead-safe renovation. See, also, **Worksite preparation level**.

**Contingency plan:** A document that describes an organized, planned, and coordinated course of action to be taken during any event that threatens human health or the environment, such as a fire, explosion, or the release of hazardous waste or its constituents from a treatment, storage, or disposal facility.

**Corrected Lead Concentration (CLC):** The absolute difference between the Apparent Lead Concentration and the Substrate Equivalent Lead. See, also, **Apparent Lead Concentration (ALC)** and **Substrate Equivalent Lead (SEL)**.

**Deciliter (dL):** one tenth of a liter.

**Detection limit:** The minimum amount of a substance that can be reliably measured by a particular method.

**Deteriorated paint:** Any paint coating on a damaged or deteriorated surface or fixture, or any interior or exterior lead-based paint that is peeling, chipping, blistering, flaking, worn, chalking, alligating, cracking, or otherwise becoming separated from the substrate.

**Digestion blank:** A mixture of the reagents used for digesting of paint, soil, or dust matrixes but without the matrix. The blank undergoes all the steps of the analysis, starting with digestion. The blank is used to evaluate the contamination process from a laboratory.

**Direct-reading XRF:** An analyzer that provides the operator with a display of lead concentrations calculated from the lead K shell X ray intensity without a graphic of the spectrum usually in mg/cm<sup>2</sup> (milligrams of lead per square centimeter of painted surface area). See, also, **XRF analyzer**.

**Disposal (of waste):** The discharge, deposit, injection, dumping, spilling, leaking, or placement of solid or liquid waste on land or in water so that none of its constituents can pollute the environment by being emitted into the air or discharged into a body of water, including groundwater.

**Disposal facility:** A facility or part of one in which waste is placed on land or in water to remain there after the facility closes.

**Doormat:** see **Walkoff mat**.

**Dripline/foundation area:** The area within 3 feet out from the building wall and surrounding the perimeter of a building.

**Dust-lead hazard:** Surface dust in residences that contains an area or mass concentration of lead equal to or in excess of the standard established by the EPA under Title IV of the Toxic Substances Control Act. EPA standards for dust-lead hazards, which are based on wipe samples, are published at 40 CFR 745.65(b); as of the publication of this edition of these *Guidelines*, these are 40 µg/ft<sup>2</sup> on floors and 250 µg/ft<sup>2</sup> on interior windowsills. (As of the publication of this edition of these *Guidelines*, in response to a petition received by the EPA on August 10, 2009, HUD and EPA are collaboratively considering whether to lower the dust-lead hazard thresholds.) Also called **Lead-contaminated dust**.

Notes:

- ◆ These *Guidelines*' related recommended standards for lead hazard screens, for which fewer samples are taken than in a risk assessment, are 25 µg/ft<sup>2</sup> for floors, and 125 µg/ft<sup>2</sup> for interior windowsills; if the results equal or exceed these levels, these *Guidelines* recommend that a full risk assessment be performed to determine if and where lead-based paint hazards truly exist). (See Chapter 5, especially Section II.I and V.D.)
- ◆ The EPA's related standards for clearance are 40 µg/ft<sup>2</sup> on floors, 250 µg/ft<sup>2</sup> on interior windowsills and 400 µg/ft<sup>2</sup> on window troughs. (40 CFR 745.227(e)(8) (viii))

**Dust removal:** A form of interim control that involves initial cleaning followed by periodic monitoring and recleaning, as needed. Depending on the severity of lead-based paint hazards, dust removal may be the primary activity or just one element of a broader control effort.

**Dust trap:** A surface, component, or furnishing that serves as a reservoir where dust can accumulate.

**EBL:** Elevated blood lead level as defined by the Centers for Disease Control and Prevention. Local standards may differ. In 2012, the CDC revised its definition to use a "reference value" of the blood lead level at the 97.5th percentile of children aged 1 to 5 years old based on its National Health and Nutrition Examination Survey (NHANES). As of the publication of this edition of these *Guidelines*, the reference level was 5 µg/dL.

**EIBLL child:** see **Environmental Intervention Blood-Lead Level (EIBLL) child**.

**Efflorescence:** The salt rising to the surface of a material, such as masonry, plaster, or cement, caused by the movement of water through the material. Paint or encapsulants may not adhere to a surface contaminated with efflorescence.

**Elastomeric:** A group of pliable, elastic liquid encapsulant coatings. An elastomer is a macromolecular material that, at room temperature, is capable of substantially recovering its size and shape after the force causing its deformation is removed (see ASTM D907, D14).

**Environmental Intervention Blood-Lead Level (EIBLL):** As defined by HUD in the Lead Safe Housing Rule (24 CFR 35.110) as of the publication of this edition of these *Guidelines*, a blood lead level of a child under age 6 years at or above 20 µg/dL in a single test or at 15-19 µg/dL in two tests taken at least three months apart (). While the term and its definition were based on guidance from the Centers for Disease Control and Prevention, in 2012 CDC revised its guidance, and it is anticipated that those laws and regulations will be reconsidered at some point. See Chapter 16.

**Encapsulation:** Any covering or coating that acts as a barrier between lead-based paint and the environment, the durability of which relies on adhesion and the integrity of the existing bonds between multiple layers of paint and between the paint and the substrate. See, also, **Enclosure**.

**Enclosure:** The use of rigid, durable construction materials that are mechanically fastened to the substrate to act as a barrier between the lead-based paint and the environment.

**Engineering controls:** Measures other than respiratory and other personal protection or administrative controls that are implemented at the worksite to contain, control, and/or otherwise reduce exposure to lead-contaminated dust and debris usually in the occupational health setting. The measures include process and product substitution, isolation, and ventilation. The term may be used in the occupational health setting in regard to preventing workers' exposures to lead; it can also be used in other lead hazard control settings, such as in regard to preventing residents' exposure.

**Evaluation:** Risk assessment, paint inspection, reevaluation, paint testing, environmental investigation, clearance examination, or risk assessment screen.

**Examination:** see **Clearance examination**.

**Exposure assessment:** The employer's sampling and analysis of the air workers breathe to determine the degree of worker exposure to lead by workers in each job classification in each work area. This involves air sampling inside the monitored workers' breathing zones, and comparison of the results to the OSHA Action Level and Permissible Exposure Limit for lead.

**Exterior work area:** For lead hazard control work, the exterior work area includes any exterior building components, such as roofs, exterior walls, the exterior portions of windows and doors, exterior stairways, fences, and unenclosed porches and patios; the safety perimeter; and access barriers, where work is being done, and the pathways and storage areas used to access those components.

**Facility (pertaining to hazardous waste):** All buildings, contiguous land, structures, and other appurtenances, as well as any improvements, where lead-based paint or hazardous waste is treated, stored, or disposed. A facility may consist of several different treatment, storage, or disposal units, such as landfills and surface impoundments.

**Federal Register (FR):** A daily Federal publication that contains proposed and final regulations, rules, and notices.

**Field blank:** A clean sample of the matrix (e.g., filter, or wipe) that has been exposed to the sampling conditions; returned to the laboratory; and analyzed as an environmental sample. Clean quartz sand, air sampling filters and cassettes, and clean wipes can be used as field blanks. The field blank, which should be treated just like the sample, indicates possible sources of contamination.

**FR:** see (FR).

**Friction surface:** Any interior or exterior surface, such as a window or stair tread, subject to abrasion or friction.

**Garden area:** An area where plants are cultivated for human consumption or for decorative purposes.

**Geometric mean:** A type of mean or average, which indicates the central tendency or typical value of a set of numbers. It is similar to the arithmetic mean, for which the numbers are added and then one  $n^{\text{th}}$  (where  $n$  is the count of numbers in the set) is found by division, except that, for the geometric mean, the numbers are multiplied and then the  $n^{\text{th}}$  root (where  $n$  is the count of numbers in the set) of the product is taken. For example, for the values 2, 2 and 16, the arithmetic mean is  $(2 + 2 + 16) / 3 = 20/3 = 6.6666+$ , and the geometric mean is  $(2 * 2 * 16)^{1/3} = 64^{1/3} = 4$ .

**Heat gun:** A device capable of heating lead-based paint causing it to separate from the substrate. For lead hazard control work, the heat stream leaving the gun should not exceed 1100°F (some authorities may use a different temperature).

**HEPA filter:** see **High Efficiency Particulate Air (HEPA) filter**.

**High Efficiency Particulate Air (HEPA) filter:** A filter capable of removing particles of 0.3 microns or larger from air at 99.97 percent or greater efficiency.

**HEPA vacuum:** A vacuum cleaner which has been designed with a HEPA filter as the last filtration stage. The vacuum cleaner must be designed so that all the air drawn into the machine is expelled through the HEPA filter with none of the air leaking past it. (Note that HUD's definition in its Lead Safe Housing Rule, with its slightly different wording, is substantively identical.)

**Household hazardous waste:** Household waste is regular garbage or trash that is disposed of as municipal waste, and managed according to state and local requirements. Waste generated in residential setting. EPA has determined that residents and contractors working in residences are entitled to manage their own LBP waste in this manner.

**Impact surface:** An interior or exterior surface (such as surfaces on doors) subject to damage by repeated impact or contact.

**Incinerator:** An enclosed device using controlled flame combustion that neither meets the criteria for classification as a boiler nor is listed as an industrial furnace.

**Indian Housing Agency:** An agency within an Indian tribal government that receives grants and provides assistance (under the United States Housing Act of 1937) for affordable housing activities for Indians.

**Industrial hygienist:** A person having a college or university degree in engineering, chemistry, physics, medicine, or a related physical or biological science who, by virtue of special training, is qualified to anticipate, recognize, evaluate, and control environmental and occupational health hazards and the impact of those hazards on the community and workers.

**In-place management:** see **Interim controls**.

**Inspection (of paint):** A surface-by-surface investigation to determine the presence of lead-based paint (in some cases including dust and soil sampling) and a report of the results.

**Inspector (more formally, Lead-Based Paint Inspector):** An individual who has successfully completed training from an accredited program and been licensed or certified by the appropriate State or local agency to:

- (1) perform inspections to determine and report the presence of lead-based paint on a surface-by-surface basis through on-site testing;
- (2) report the findings of such an inspection;
- (3) collect environmental samples for laboratory analysis;
- (4) perform clearance testing; and optionally
- (5) document successful compliance with lead-based paint hazard control requirements or standards.

**Interim controls:** A set of measures designed to temporarily reduce human exposure or possible exposure to lead-based paint hazards. Such measures include, but are not limited to, specialized cleaning, repairs, maintenance, painting, temporary containment, and the establishment and operation of management and resident education programs. Monitoring, conducted by owners, and reevaluations, conducted by professionals, are integral elements of interim control. Interim controls include dust removal; paint film stabilization; treatment of friction and impact surfaces; installation of soil coverings, such as grass or sod; and land use controls. Interim controls that disturb painted surfaces are renovation activities under EPA's Renovation, Repair and Painting Rule. See, also, **Monitoring, Reevaluation, and Abatement**.

**Interior windowsill:** The portion of the horizontal window ledge that protrudes into the interior of the room, adjacent to the window sash when the window is closed; often called the window stool.

**Investigation (pertaining to EIBLL cases only):** The process of determining the source of lead exposure for a child or other resident with an elevated blood lead level. Investigation consists of administration of a questionnaire, comprehensive environmental sampling, case management, and other measures.

**Investigator:** A person who conducts an investigation of a dwelling where a resident has an environmental intervention blood lead level. The investigator must be proficient in interviewing techniques, environmental sampling, and the interpretation of risk assessment and environmental sampling data.

**Laboratory analysis:** A determination of a sample by a qualified laboratory using a defined method meeting specified performance and quality criteria. In the case of analysis of samples of lead in paint, dust or soil in target housing or pre-1978 child-occupied facilities, the laboratory must be recognized by NLLAP. Among the methods used by these laboratories for determining lead content are atomic absorption spectroscopy (AAS), inductively coupled plasma emission spectroscopy (ICP), or laboratory-based K or L X-ray fluorescence, or an equivalent method.

**Landfill:** A State licensed or State permitted disposal facility that meets municipal solid waste standards.

**Latex:** A waterborne emulsion paint made with synthetic binders, such as 100 percent acrylic, vinyl acrylic, terpolymer, or styrene acrylic; a stable emulsion of polymers and pigment in water.

**LBP:** Lead-based paint.

**Lead:** Lead includes metallic lead and inorganic and organic compounds of lead.

**Lead-based paint:** Any paint, varnish, shellac, or other coating that contains lead equal to or greater than 1.0 mg/cm<sup>2</sup> as measured by XRF or laboratory analysis, or 0.5 percent by weight (5000 mg/g, 5000 ppm, or 5000 mg/kg) as measured by laboratory analysis. (Local definitions may vary.) (As of the publication of this edition

of these *Guidelines*, in response to a petition received by the EPA on August 10, 2009, HUD and EPA are collaboratively considering whether to lower the threshold levels of lead-based paint.)

**Lead-based paint abatement planner/designer:** An individual who has completed an accredited training program on planning and designing lead-based paint hazard control projects.

**Lead-based paint abatement worker:** see **Worker**.

**Lead-based paint free:** A property where no lead in amounts greater than or equal to 1.0 mg/cm<sup>2</sup> in paint (or surface coatings) was found on any building components, using the inspection protocol in Chapter 7 of the HUD *Guidelines for the Evaluation and Control of Lead-Based Paint Hazards in Housing* (2012 Revision).

Notes:

- ◆ A lead-based paint-free property may contain lead incorporated into components that are not lead-based painted, such as ceramic tile, or painted components below the standard stated in this definition.
- ◆ Some states and localities have a lower threshold for the definition of lead-based paint.
- ◆ OSHA does not consider whether paint is lead-based paint in its regulations; its regulations focus on whether workers may be exposed to lead whatever the source.

**Lead-based paint hazard:** A condition in which exposure to lead from lead-contaminated dust, lead-contaminated soil, or deteriorated lead-based paint would have an adverse effect on human health (as established by the EPA at 40 CFR 745.65, under Title IV of the Toxic Substances Control Act). Lead-based paint hazards include, for example, **paint-lead hazards**, **dust-lead hazards**, and **soil-lead hazards**.

**Lead-based paint hazard control:** Activities intended to control and eliminate lead-based paint hazards, including but not limited to interim controls and abatement.

**Lead-based paint inspector** or **Lead paint inspector:** see **Inspector**.

**Lead-based paint risk assessor:** see **Risk Assessor**.

**Lead carbonate:** A pigment used in some lead-based paints as a hiding agent; also known as white lead.

**Lead-contaminated dust:** See **Dust-lead hazard**.

**Lead-contaminated soil:** See **Soil-lead hazard**.

**Lead-containing paint:** As defined by the Consumer Product Safety Commission, paint or other similar surface coating materials for consumer use that contain lead or lead compounds and in which the lead content (calculated as lead metal) is in excess of 0.009 percent by weight of the total nonvolatile content of the paint or the weight of the dried paint film (see 16 CFR 1303.1(c)).

**Lead hazard screen:** A method of determining, in buildings in good condition, whether they should have a full risk assessment. The screen uses fewer samples but more stringent evaluation criteria (standards) than regular risk assessments. Also called a **risk assessment screen**.

**Lead-poisoned child:** A child with an elevated blood level (see **EBL**).

**Lead-specific detergent:** A cleaning agent manufactured specifically for cleaning and removing leaded dust or other lead contamination.

**Leaded dust:** see **Lead-contaminated dust**.

**Licensed:** Holding a valid license or certification issued by EPA or by an EPA-authorized State or Tribal program pursuant to Title IV of the Toxic Substances Control Act. The license is based on certification for lead-based paint hazard evaluation or control work. See, also, **Certified**.

**Maintenance:** In the context of lead hazard control, work intended to maintain adequate living or occupancy conditions in target housing or a pre-1978 child-occupied facility; it may have the potential to disturb known or presumed lead-based paint.

**Mat:** See **Walkoff mat**.

**Matrix blank:** A sample of the matrix (paint chips, soil, or dust) that does not contain the analyte lead. This sample goes through the complete analysis, including digestion.

**MDL:** see **Method detection limit**.

**Mean:** The arithmetic average of a series of numerical data values; for example, the algebraic sum of the data values divided by the number of data values. Synonymous with **Arithmetic mean** and **Average**. See, also, the related term **Standard Deviation**.

**Medical removal:** The temporary removal of an employee from the job because the employee's blood lead level is at or above 50 µg/dL of the occurrence of an adult "elevated blood lead level" as defined in the OSHA Lead Exposure in Construction standard (29 CFR 1926.62(k)(1)(i)).

**Method blank:** see **Digestion blank**.

**Method detection limit (MDL):** The minimum concentration of an analyte that, for a given matrix and method, has a 99 percent probability of being identified, qualitatively or quantitatively measured, and reported to be greater than zero.

**mg:** Milligram; 1/1000 of a gram.

**µg (or mcg):** Microgram. The prefix micro means 1/1,000,000 (or one-millionth); a microgram is 1/1,000,000 of a gram and 1/1000 of a milligram; equal to about 35/1,000,000,000 (35 billionths) of an ounce (an ounce is equal to 28,400,000 mg).

**Microgram:** see **µg**.

**Mil:** 1/1000 of an inch; used to measure thickness.

**Milligram:** see **mg**.

**Monitoring:** An organized program of regular surveillance to determine that:

- (1) known or presumed lead-based paint is not deteriorating;
- (2) lead-based paint hazard controls, such as paint stabilization, interim control measures for soil, enclosure, or encapsulation have not failed;
- (3) structural problems do not threaten the integrity of hazard controls or of known or presumed lead-based paint, and
- (4) dust lead levels have not risen above applicable standards.

There are two types of monitoring activities: visual surveys by property owners and reevaluations by certified risk assessors. Visual surveys are generally conducted annually and at rental housing unit turn-over for the purpose of making the first three determinations listed above. Monitoring is not required in properties known to be free of lead-based paint. See also **Reevaluation**.

Note: Worker exposures must be monitored for lead; this is a different sense of “monitoring” than the facility and operational monitoring discussed above. See **Exposure Assessment**, Chapter 9 and Appendix 6.

**Mouthable surface:** see **Chewable surface**.

**Multifamily housing:** Housing that contains more than one dwelling unit per location. HUD, the U.S. Department of Agriculture, and other agencies’ programs may use a larger number of units, such as five or ten, to differentiate single family housing from multifamily housing in their regulations.

**NLLAP requirements:** Requirements specified by the EPA National Lead Laboratory Accreditation Program (NLLAP), for accreditation for the lead analysis of paint, soil, and dust matrixes by an EPA-recognized laboratory accreditation organization.

**Offsite paint removal:** The process of removing a component from a building and stripping the paint from the component at a paint stripping facility away from the building’s property.

**Ongoing monitoring:** see **Monitoring**.

**Owner:** A person, firm, corporation, guardian, conservator, receiver, trustee, executor, government agency or entity, or other judicial officer who, alone or with others, owns, holds, or controls the freehold or leasehold title or part of the title to property, with or without actually possessing it. This definition includes a vendee who possesses the title, but does not include a mortgagee or an owner of a reversionary interest under a ground rent lease.

**Oxidation:** An example of a chemical reaction that occurs upon exposure to oxygen and other oxidizing substances. Some coatings cure by oxidation; oxygen enters the liquid coating and cross links (attaches) the resin molecules. This film-forming method is also called “air cure” or “air dry.” Oxidation also causes rust to form on metals and paint to chalk.

**Paint-lead hazard:**

Lead-based paint on a friction surface that is subject to abrasion and where a dust-lead hazard is present on the nearest horizontal surface underneath the friction surface (e.g., the window sill, or floor);

Damaged or otherwise deteriorated lead-based paint on an impact surface that is caused by impact from a related building component;

A chewable lead-based painted surface on which there is evidence of teeth marks; or

Any other deteriorated lead-based paint in any residential building or child-occupied facility or on the exterior of any residential building or child-occupied facility.

**Paint stabilization:** The process of wet scraping, priming, and repainting surfaces coated with deteriorated lead-based paint. Paint stabilization also includes eliminating the cause(s) of paint deterioration, cleanup and clearance.

**Paint removal:** The removal of lead-based paint from surfaces; this may be an abatement strategy, or it may occur as a part of a renovation project.

**Patch test:** A test method or procedure to assess the adhesion of an encapsulant coating to a substrate covered with a layer or layers of lead-based paint.

**Personal breathing zone samples:** Air samples collected from the breathing zone of a worker (within a 1 foot radius of the worker's mouth) but outside the respirator. With respect to assessing lead exposures, the samples are collected with a personal sampling pump operating at 2 liters per minute, drawing air through a 37 mm mixed cellulose ester filter housed in a closed-face cassette with a pore size of 0.8 micrometers. See **Exposure assessment**.

**Personal Protective Equipment (PPE):** Equipment for protecting the eyes, face, head, and/or extremities; includes protective clothing, respiratory devices, and protective shields; used when hazards capable of causing bodily injury or impairment are encountered.

**PHA:** see **Public Housing Agency (PHA)**.

**Pigment:** Insoluble, finely ground materials that give paint its properties of color and hide.

**Plastic:** see **Polyethylene plastic**.

**Play area:** An area of frequent soil contact by children of under age 6 as indicated by, but not limited to, such factors including the following: the presence of outdoor play equipment (e.g., sandboxes, swing sets, and sliding boards), toys, or other children's possessions, observations of play patterns, or information provided by parents, residents, care givers, or property owners.

**Polyethylene plastic:** Polyethylene plastic or any other thick plastic material shown to demonstrate at least equivalent performance in containing dust and waste, resist tearing, and, after being properly sealed, remain leak tight with no visible signs of discharge during movement or relocation.

**Polyurethane:** An exceptionally hard and wear-resistant coating created by the reaction of polyols with a multifunctional isocyanate; often used to seal wood floors following lead-based paint hazard control work and cleaning.

**Precision:** The degree to which a set of observations or measurements of the same property, usually obtained under similar conditions, conform to themselves; a data quality indicator. Precision is usually expressed in either absolute or relative terms as standard deviation, variance, or range. Often known as "reproducibility." See also the related, but different, term **Accuracy**.

**Primary prevention:** The process of preventing lead hazards from occurring and, when they do occur, controlling lead hazards to prevent exposure *before* a child is poisoned. See, also, **Secondary prevention** and **Tertiary prevention**.

**Primary standard:** A substance or device with a property or value that is unquestionably accepted, within specified limits, in establishing the value of the same or related property of another substance or device.

**Public Housing Agency (PHA):** Any State, county, municipality, or other government entity or public body, or agency or instrumentality thereof, authorized to engage or assist in the development or operation of housing for low-income families.

**Quality Assurance (QA):** An integrated system of activities involving planning, quality control, quality assessment, reporting, and quality improvement to ensure that a product or service meets defined standards of quality within a stated level of confidence.

**Quality Control (QC):** The overall system of technical activities whose purpose is to measure and control the quality of a product or service so that it meets the needs of users. The aim is to provide a level of quality that is satisfactory, adequate, dependable, and economical.

**Random sample:** A sample drawn from a population in a way that allows each member of the population to have an equal chance of being selected. Random sampling is a process used to identify locations for the lead-based paint inspections in multifamily dwellings. See, also, **Targeted sample** and **Worst-case sample**.

**RCRA:** see **Resource Conservation and Recovery Act (RCRA)**.

**Recognized laboratory:** A laboratory that has been evaluated by the EPA's National Lead Laboratory Accreditation Program (NLLAP), and has demonstrated the capability to accurately analyze paint chip, dust, or soil samples for lead; the recognition for analysis of lead in a particular medium is held for a specified period of time, subject to continued quality control testing under the NLLAP.

**Reevaluation:** The combination of a visual assessment and collection of dust and, as appropriate, soil samples performed by a certified risk assessor to determine if the housing is free of lead-based paint hazards, and determine whether previously implemented lead-based paint hazard control measures are still effective.

**Reference material:** A material or substance that has at least one sufficiently well established property that can be used to calibrate an apparatus, assess a measurement method, or assign values to materials.

**Removal:** see **Paint removal**.

**Renovation:** According to EPA, the modification of any existing structure, or a portion of it, that results in the disturbance of painted surfaces, unless it is performed as part of an abatement or is a minor repair and maintenance activity, as these terms are defined by 40 CFR 745.223 and 745.83, respectively; see Appendix 6. The term renovation includes (but is not limited to): The removal, modification or repair of painted surfaces or painted components (e.g., modification of painted doors, surface restoration, window repair, surface preparation activity (such as sanding, scraping, or other such activities that may generate paint dust)); the removal of building components (e.g., walls, ceilings, plumbing, windows); weatherization projects (e.g., cutting holes in painted surfaces to install blown-in insulation or to gain access to attics, planing thresholds to install weather-stripping), and interim controls that disturb painted surfaces. A renovation performed for the purpose of converting a building, or part of a building, into target housing or a child-occupied facility is a renovation under this subpart.

**Renovator:** An individual who either performs or directs workers who perform renovations. Under EPA's Renovation, Repair, and Painting (RRP) Rule, a **Certified Renovator**.

**Replacement:** A strategy of abatement that involves the removal of building components coated with lead-based paint (such as windows, doors, and trim) and the installation of new components free of lead-based paint.

**Reporting Limit:** This value describes what a laboratory has determined as the lowest lead value it can report with sufficient confidence (such as 95% confidence) for the amount of the analyte (e.g., lead) in the matrix of interest (e.g., paint, dust, or soil).

**Representative sample:** A sample of a universe or whole (e.g., bare soil sample, waste sample pile, groundwater, or waste stream) that can be expected to exhibit the average properties of the entire universe or whole.

**Resident:** A person who regularly lives in a dwelling. A person who is not regularly living in the dwelling unit but is present when lead hazard control work is being done is an occupant of the dwelling who deserves the same level of protection as the residents of the dwelling.

**Resource Conservation and Recovery Act (RCRA):** The primary Federal statute governing waste management from generation to disposal. RCRA defines the criteria for hazardous and nonhazardous waste.

**Risk assessment:** An on-site investigation of a residential dwelling to determine the existence, nature, severity, and location of lead-based paint hazards. Risk assessments, which must be conducted by a certified risk assessor, include an investigation of the age, history, management, and maintenance of the dwelling, and the number of children under age 6 and women of childbearing age who are residents; a visual assessment; limited randomized environmental sampling (i.e., collection of dust wipe samples, soil samples, and deteriorated paint samples); and preparation of a report identifying abatement and interim control options based on specific conditions. HUD's Lead Safe Housing Rule requires risk assessments for certain types and amounts of HUD assistance; in these cases, a risk assessment must be no more than 12 months old to be considered current.

**Risk assessment screen:** See **Lead hazard screen**.

**Risk assessor:** A certified individual who has successfully completed lead-based paint hazard risk assessment training with an accredited training program and who has been certified to:

- (1) perform risk assessments;
- (2) identify acceptable abatement and interim control strategies for reducing identified lead-based paint hazards;
- (3) perform clearance testing and reevaluations; and
- (4) document the successful completion of lead-based paint hazard control activities.

**RL:** see **Reporting Limit (RL)**

**Room Equivalent:** A room equivalent is an identifiable part of a residence (e.g., room, house exterior, foyer, etc.).

**Sample site:** A specific spot on a surface being tested for lead loading or concentration.

**Sampling Technician:** A person who has completed a EPA-accredited or EPA-authorized State-accredited training course for sampling technicians and is qualified to perform clearance examinations after certain interim control activities. (Previously known as a clearance technician.)

**Saponification:** The chemical reaction between alkalis and oil that produces a type of soap. Because of saponification, oil and alkyd coatings will not adhere to masonry substrates, galvanized metals, or zinc-rich primers.

**Screen:** See **Lead hazard screen**.

**Screening:** The process of testing children to determine if they have elevated blood lead levels.

**Secondary prevention:** The process of identifying children who have elevated blood lead levels, and controlling or eliminating the sources of further exposure. See, also, **Primary prevention** and **Tertiary prevention**.

**Secondary standard:** A reference material with a well-defined, high quality, traceability linkage to existing **primary standards** for the same measurements. **SEL:** see **Substrate Equivalent Lead (SEL)**.

**Site:** Regarding hazardous waste, the land or body of water where a facility is located or an activity is conducted. The site includes adjacent land used in connection with the facility or activity. (See Chapter 10.)

**Small quantity generator:** Owners, contractors (generators), or both who produce less than 100 kg of hazardous waste per month and accumulate less than 100 kg of hazardous waste at any one time, or who produce less than 1 kg of *acutely* hazardous waste per month and accumulate less than 1 kg of *acutely* hazardous waste at any one time. (See Chapter 10.)

**Soil-lead hazard:** Bare soil on residential property that contains lead in excess of the standard established by the EPA under Title IV of the Toxic Substances Control Act. EPA standards for soil-lead hazards, published at 40 CFR 745.65(c), as of the publication of this edition of these *Guidelines*, is 400 µg/g in play areas and 1,200 µg/g in the rest of the yard. Also called **Lead-contaminated soil**.

**Spectrum analyzer:** A type of XRF analyzer that provides the operator with a plot of the energy and intensity, or counts, of K shell and/or L shell X-ray spectra, as well as a calculated lead concentration. See, also, **XRF analyzer**.

**Spiked matrix:** See **Spiked sample**.

**Spiked sample:** A sample prepared by adding a known mass of the target analyte (e.g., lead, as in leaded dust) to a specific amount of matrix sample (e.g., a dust wipe) for which an independent estimate of the target analyte mass is available. Spiked samples are used to determine, for example, the effect of the matrix on a method's recovery efficiency. See, also, the related term **Blind sample**.

**Spot prime:** To apply a paint primer to localized areas of exposed substrate.

**Standard deviation:** A measure of the precision of a reading; the spread of the deviation from the mean. The smaller the standard deviation, the more precise the analysis. The standard deviation is calculated by first obtaining the mean, or the arithmetic average, of all of the readings. A formula is then used to calculate how much the individual values vary from the mean – the standard deviation is the square root of the arithmetic average of the squares of the deviation from the mean. Many hand calculators and computer spreadsheets have an automatic standard deviation function. See, also, **Mean**.

**Standard reference material (SRM):** A certified reference material produced by the National Institute of Standards and Technology (NIST at the U.S. Department of Commerce) and characterized for absolute content independent of analytical method. See, also, **Certified reference material**.

**Subsample:** A constituent portion of a sample. A subsample may be either a field subsample or a laboratory subsample, depending on where the subsample is created. A subsample may be combined with other subsamples to produce a composite sample. See, also, **Composite sample**.

**Substrate:** A surface on which paint, varnish, or other coating has been applied or may be applied. Examples of substrates include wood, plaster, metal, and drywall.

**Substrate effect:** The radiation returned to an XRF analyzer by the paint, substrate, or underlying material, in addition to the radiation returned by any lead present. This radiation, when counted as lead X-rays by an XRF analyzer contributes to substrate equivalent lead (bias). The inspector may have to compensate for this effect when using XRF analyzers. See, also, **XRF analyzer**.

**Substrate Equivalent Lead (SEL):** The XRF measurement taken on an unpainted surface; used to calculate the corrected lead concentration on a surface by using the following formula: Apparent Lead Concentration - Substrate Equivalent Lead = Corrected Lead Concentration. See, also, **Apparent Lead Concentration (ALC)**, **Corrected Lead Concentration (CLC)**, and **XRF analyzer**.

**Target housing:** Any housing constructed before 1978 – except dwellings that do not contain bedrooms, or dwellings that are designated specifically for the elderly or persons with disabilities, unless a child younger than 6 resides or is expected to reside in the dwelling. In the case of jurisdictions that banned the sale or use of lead-based paint before 1978, the Secretary of HUD may designate an earlier date for defining target housing.

**Targeted sample:** A sample of dwelling units selected from an apartment building or housing development using information supplied by the owner, and not by random selection or on the basis of visual evidence obtained by the risk assessor. Based on the owner's information, the units are selected to have the greatest probability of containing lead-based paint hazards. See, also, **Worst-case sample** and **Random sample**.

**TCLP:** see **Toxicity Characteristic Leaching Procedure (TCLP)**.

**Tribally-Designated Housing Entity:** A designation by an Indian tribe's authority (i.e., tribal council or like body) of an entity other than the tribal government to receive grants and provide assistance under the Native American Housing Assistance and Self-Determination Act (P.L. 104-330 as amended) for affordable housing activities for Indians.

**Tertiary prevention:** Providing medical treatment to children with elevated blood lead levels to prevent more serious injury or death.

**Testing combination:** A unique surface to be tested that is characterized by the room equivalent, component, and substrate.

**Test location:** A specific area on a testing combination where XRF instruments will test for lead-based paint.

**Toxicity Characteristic Leaching Procedure (TCLP):** A laboratory test to determine if excessive levels of lead or other hazardous materials could leach from a sample into groundwater; usually used to determine if waste is hazardous based on its toxicity characteristics. (See Chapter 10.)

**Trained:** Successful completion of a training course in a particular discipline. For lead hazard evaluation or control work, the training course must be accredited by EPA or by an EPA-authorized State or tribal program, pursuant to Title IV of the Toxic Substances Control Act.

**Treatment:** A method designed to control lead-based paint hazards. Treatment includes interim controls, abatement, and removal.

**Trisodium phosphate (TSP) detergent:** A detergent that contains trisodium phosphate. These guidelines do not recommend using TSP.

**Trough:** see **Window trough**.

**Truck-mounted vacuum unit:** A vacuum system whose components, except for hoses and attachments, are located outside the building undergoing dust removal. The exhaust is vented outside so that the interior dust is not disturbed.

**TSD:** see **Treatment, Storage, and Disposal (TSD) facility**.

**TSP:** see **Trisodium phosphate (TSP) detergent**.

**Useful life:** The life expectancy of a coating before it requires refinishing or some other form of maintenance.

**Vacuum/wet cleaning/vacuum cycle:** The cleaning cycle that begins with HEPA vacuuming, followed by a wet cleaning with a detergent, followed by a final pass with a HEPA vacuum over the surface.

**VOC:** see **Volatile Organic Compound (VOC)**.

**Volatile Organic Compound (VOC):** Organic (carbon-based) substances that evaporate from a coating, such as during the coating or curing process.

**Walkoff mat:** A washable, fibrous material (preferably with a rubber or vinyl backing) positioned at an entryway to reduce transport of lead dust and/or lead soil into a building, or out of a work area.

**White lead:** A white pigment, usually lead carbonate. See, also, **Lead carbonate**.

**Windowsill:** see **Interior windowsill**.

**Window stool:** see **Interior windowsill**.

**Window trough:** For a typical double hung window, the portion of the exterior windowsill between the interior windowsill (or stool) and the frame of the storm window. If there is no storm window, the window trough is the area that receives both the upper and lower window sashes when they are both lowered. (Sometimes inaccurately called a window “well.”) See, also, **Window well**.

**Window well:** The space that provides exterior access and/or light to a window that is below grade, i.e., below the level of the surrounding earth or pavement. See, also, **Window trough**.

**Worksite:** Any interior or exterior area where lead-based paint hazard control work takes place. There may be more than one worksite in a dwelling unit or at a residential property.

**Worksite preparation activities:** A set of measures designed to protect residents and the environment from leaded dust, paint chips, or other forms of lead contamination through the erection of barriers and the establishment of access control, resident relocation or movement restrictions, warning signs, ventilation, engineering controls, and other measures.

**Worst case sample:** A sample of dwelling units having the greatest probability of containing lead-based paint hazards selected by a risk assessor on the basis of the risk assessor’s visual examination of all dwelling units in a housing development or apartment building. See, also, **Targeted sample** and **Random sample**.

**XRF analyzer:** An instrument that determines lead concentration in milligrams per square centimeter (mg/cm<sup>2</sup>) using the principle of X-ray fluorescence (XRF). Two types of XRF analyzers are used – direct readers and spectrum analyzers. In these *Guidelines*, the term XRF analyzer generally refers to portable instruments manufactured to analyze paint, and does not refer to laboratory grade units. Some portable instruments can be used to analyze lead in dust or soil.

# **SECTION 13**

## **Lead Abatement Waste Management Policy**

**Rules Changed to Help Accelerate Lead-based Paint  
Removal**

**Disposal of Residential Lead-Based Paint**



United States  
Environmental Protection  
Agency

June 2003  
EPA530-F-03-007  
[www.epa.gov/osw](http://www.epa.gov/osw)

## Rules Changed To Help Accelerate Lead-based Paint Removal

*The Environmental Protection Agency is reducing costs and removing obstacles associated with the disposal of residential lead-based paint. This action will speed up the removal of lead-based paint from older residences, and thereby reduce health risks to children from lead.*

### **Action**

Construction and demolition (C&D) landfills are allowed to accept residential lead-based paint (LBP) waste for disposal. So long as these landfills do not accept any other household waste, they do not have to change their current operating practices and procedures. Municipal solid waste landfills also may continue to dispose of residential lead-based paint.

This rule applies to residential LBP waste from abatement, rehabilitation, renovation, or remodeling in homes, residences, and other households. "Household" means single and multiple residences, hotels and motels, bunkhouses, ranger stations, crew quarters, campgrounds, picnic grounds, and day-use recreation areas. Individuals and firms who create residential lead-based paint waste, such as contractors and do-it-yourselfers, may dispose of LBP waste from these households at C&D landfills.

### **For More Information**

Information about this rule and the disposal of residential lead-based paint is available on the Internet at: <http://www.epa.gov/epaoswer/non-hw/muncpl/landfill/pb-paint.htm>. Technical assistance may be obtained from the RCRA Call Center. Callers within the Washington Metropolitan Area, please dial 703-412-9810 or TDD 703-412-3323 (hearing impaired). Long-distance callers may call 1-800-424-9346 or TDD 1-800-553-7672.

an accountable process to ensure “meaningful and timely input by tribal officials in the development of regulatory policies that have tribal implications.” “Policies that have tribal implications” is defined in the Executive order to include regulations that have “substantial direct effects on one or more Indian tribes, on the relationship between the Federal Government and the Indian tribes, or on the distribution of power and responsibilities between the Federal Government and Indian tribes.” This rule will not have substantial direct effects on tribal governments, on the relationship between the Federal Government and Indian tribes, or on the distribution of power and responsibilities between the Federal Government and Indian tribes, as specified in Executive Order 13175. Thus, Executive Order 13175 does not apply to this rule.

**VIII. Congressional Review Act**

The Congressional Review Act, 5 U.S.C. 801 *et seq.*, as added by the Small Business Regulatory Enforcement Fairness Act of 1996, generally provides that before a rule may take effect, the agency promulgating the rule must submit a rule report, which includes a copy of the rule, to each House of the Congress and to the Comptroller General of the United States. EPA will submit a report containing this rule and other required information to the U.S. Senate, the U.S. House of Representatives, and the Comptroller General of the United States prior to publication of this final rule in the **Federal Register**. This final rule is not a “major rule” as defined by 5 U.S.C. 804(2).

**List of Subjects in 40 CFR Part 180**

Environmental protection, Administrative practice and procedure, Agricultural commodities, Pesticides and pests, Reporting and recordkeeping requirements.

Dated: June 6, 2003.

**Debra Edwards,**

*Director, Registration Division, Office of Pesticide Programs.*

■ Therefore, 40 CFR chapter I is amended as follows:

**PART 180—[AMENDED]**

■ 1. The authority citation for part 180 continues to read as follows:

**Authority:** 21 U.S.C. 321(q), 346(a) and 371.

■ 2. Section 180.507 is amended by adding alphabetically commodities to the table in paragraph (a)(1) to read as follows:

**§ 180.507 Azoxystrobin; tolerances for residues.**

(a) \* \* \*

Commodity	Parts per million
* * *	*
Artichoke, globe .....	4.0
Asparagus .....	0.04
* * *	*
Brassica, head and stem, subgroup 5A .....	3.0
* * *	*
Herb subgroup 19A, dried, except chive .....	260
Herb subgroup 19A, fresh, except chive .....	50
* * *	*

[FR Doc. 03-15261 Filed 6-17-03; 8:45 am]

**BILLING CODE 6560-50-S**

**ENVIRONMENTAL PROTECTION AGENCY**

**40 CFR Parts 257 and 258**

[FRL-7514-7]

**RIN 2050-AE86**

**Criteria for Classification of Solid Waste Disposal Facilities and Practices and Criteria for Municipal Solid Waste Landfills: Disposal of Residential Lead-Based Paint Waste**

**AGENCY:** Environmental Protection Agency (EPA).

**ACTION:** Final rule.

**SUMMARY:** To help accelerate the pace of lead-based paint removal from residences, and thereby reduce exposure to children and adults from the health risks associated with lead, EPA is promulgating a change to its definition of “municipal solid waste landfill unit” in both the Criteria for Classification of Solid Waste Disposal Facilities and Practices and the Criteria for Municipal Solid Waste Landfills. In addition, EPA is promulgating two new definitions for “construction and demolition (C&D) landfill” and “residential lead-based paint waste.” This final rule will expressly allow residential lead-based paint waste that is exempted from the hazardous waste management requirements as household waste to be disposed of in construction and

demolition landfills by stating that a construction and demolition landfill accepting residential lead-based paint waste, and no other household waste, is not a municipal solid waste landfill unit. Today’s action would not prevent a municipal solid waste landfill unit from continuing to receive residential lead-based paint waste.

**DATES:** This final rule will become effective on June 18, 2003. The Agency finds good cause to make this rule effective immediately because today’s final rule provides an additional disposal option for residential lead-based paint waste.

**ADDRESSES:** Copies of the documents relevant to this action (Docket No. RCRA-2001-0017) are available for public inspection during normal business hours from 8:30 a.m. to 4:30 p.m., Monday through Friday, excluding federal holidays, at the RCRA Information Center (RIC), located at EPA West, Room B-102, 1301 Constitution Ave., NW, Washington, DC.

**FOR FURTHER INFORMATION CONTACT:** For general information, contact the RCRA Hotline at (800) 424-9346 or TDD (800) 553-7672 (hearing impaired). In the Washington, DC, metropolitan area, call (703) 412-9810 or TDD (703) 412-3323.

For information on specific aspects of this rule, contact Paul Cassidy, Municipal and Industrial Solid Waste Division, Office of Solid Waste (mail code 5306W), U.S. Environmental Protection Agency (EPA, HQ), 1200 Pennsylvania Avenue, NW, Washington, DC 20460; (703) 308-7281, [cassidy.paul@epa.gov](mailto:cassidy.paul@epa.gov). The index and some supporting materials are available on the Internet. You can find these materials at <http://www.epa.gov/epaoswer/non-hw/muncpl/landfill/pb-paint.htm>.

**SUPPLEMENTARY INFORMATION:**

**I. General Information**

*A. Regulated Entities*

Entities potentially covered by this regulation are public or private individuals or groups that generate residential lead-based paint (LBP) waste as a result of abatement, rehabilitation, renovation and remodeling in homes, residences, and other households. By “households,” we mean single and multiple residences, hotels and motels, bunkhouses, ranger stations, crew quarters, campgrounds, picnic grounds, and day-use recreation areas. Affected categories and entities include:

Category	Examples of affected entities
Individuals and firms who generate residential LBP wastes.	Contractors and do-it-yourselfers who generate and dispose of residential LBP waste as a result of abatement, rehabilitation, renovation and remodeling in homes, residences, and other households.
Construction and demolition waste disposal firms.	Owners or operators of construction and demolition landfills that accept residential LBP waste for disposal.

The table above is not intended to be exhaustive but, rather, is intended to provide examples of entities likely to be regulated by this action. To determine whether your facility would be impacted by this action, you should carefully examine the applicability criteria in this rule. If you have questions regarding the applicability of this action to a particular facility, please contact Paul Cassidy, U.S. EPA, Office of Solid Waste (5306W), 1200 Pennsylvania Ave. NW., Washington, DC 20460; telephone 703-308-7281; e-mail: [cassidy.paul@epa.gov](mailto:cassidy.paul@epa.gov).

**B. How Can I Get Copies of This Document and Other Related Information?**

1. *Docket.* EPA has established an official public docket for this action under Docket ID No. RCRA-2001-0017. The official public docket consists of the documents specifically referenced in this action, any public comments received and other information related to this action. The official public docket is the collection of materials that is available for public viewing at the RCRA Information Center (RIC), located at EPA West, Room B-102, 1301 Constitution Ave. NW., Washington DC. The Docket Facility is open from 8:30 a.m. to 4:30 p.m., Monday through Friday, excluding legal holidays. The telephone number for the Public Reading Room is (202) 566-1744. In the Washington, DC, metropolitan area, call 202-566-0270 or TDD 703-412-3323 (hearing impaired). To review the docket materials in person, we recommend that the public make an appointment by calling 202-566-0270. The public can copy a maximum of 100 pages from the docket at no charge. Additional copies cost \$0.15/page. If you access the information electronically, you can download or print copies free of charge.

2. *Electronic Access.* You may access this **Federal Register** document electronically through the EPA Internet under the “**Federal Register**” listings at <http://www.epa.gov/fedrgstr>.

An electronic version of the public docket is available through EPA’s electronic public docket and comment system, EPA Dockets. You may use EPA Dockets at <http://www.epa.gov/edocket/> to access the index listing of the

contents of the official public docket, and to access those documents in the public docket that are available electronically. Once in the system, select “search,” then key in the appropriate docket identification number. Although not all docket materials may be available electronically, you may still access any of the publicly available docket materials through the docket facility identified above in Unit I.B.

**C. Acronyms**

Acronym	Definition
CDC	Centers of Disease Control and Prevention.
C&D	Construction and Demolition.
CFR	Code of Federal Regulations.
EA	Economic Analysis.
EPA	Environmental Protection Agency.
FR	Federal Register.
HUD	U.S. Department of Housing and Urban Development.
IQ	Intelligence Quotient.
LBP	Lead-Based Paint.
MSWLF	Municipal Solid Waste Landfill.
OMB	Office of Management and Budget.
OPPTS	Office of Prevention, Pesticides, and Toxic Substances.
OSWER	Office of Solid Waste and Emergency Response.
RCRA	Resource Conservation and Recovery Act.
RIC	RCRA Docket Information Center.
TC	Toxicity Characteristic.
TCLP	Toxicity Characteristic Leaching Procedure.
TSCA	Toxic Substances Control Act.
USEPA	United States Environmental Protection Agency.

**Outline**

- I. Legal Authority
- II. Summary of Proposed Lead-Based Paint Rule
  - A. Proposed Change to the Definition of “Municipal Solid Waste Landfill (MSWLF) Unit”
  - B. Proposed Definition of “Construction and Demolition (C&D) Landfill”
  - C. Proposed Definition of “Residential Lead-Based Paint Waste”
  - D. Rationale for Proposed Rule
- III. Summary of Public Comments and the Agency’s Responses to those Comments
- IV. Other Applicable Federal, State, Tribal, and Local Requirements

V. How Will States and Tribes Implement this Rule?

VI. How Does this Rule Comply with Applicable Statutes and Executive Orders? Statutory and Executive Order Reviews

- A. Executive Order 12866: Regulatory Planning and Review
- B. Paperwork Reduction Act
- C. Regulatory Flexibility Act
- D. Unfunded Mandates Reform Act
- E. Executive Order 13132: Federalism
- F. Executive Order 13175: Consultation and Coordination with Indian Tribal Governments
- G. Executive Order 13045: Protection of Children from Environmental Health Risks and Safety Risks
- H. Executive Order 13211: Actions that Significantly Affect Energy Supply, Distribution, or Use
- I. National Technology Transfer and Advancement Act of 1995
- J. Executive Order 12898: Federal Actions to Address Environmental Justice in Minority Populations and Low-Income Populations
- K. Congressional Review Act

**I. Legal Authority**

EPA is promulgating this rule pursuant to section 1008(a)(3), 2002(a), 4004(a) and 4010(c) of the Resource Conservation and Recovery Act (RCRA), 42 U.S.C. Secs. 6907(a), 6912(a), 6944(a), 6949a(c). We are also correcting a typographical error in the existing statement of authority in part 257 by amending the citation to 42 U.S.C. 6949(c) to read “6949a(c).”

**II. Summary of Proposed Lead-Based Paint Rule**

*A. Proposed Change to the Definition of “Municipal Solid Waste Landfill (MSWLF) Unit”*

In its October 23, 2001, proposal (see 66 FR 53566-53573) regarding the disposal of residential lead-based paint waste, the Agency proposed to expressly allow construction and demolition landfills to receive residential lead-based paint (LBP) waste.<sup>1</sup> This was to be accomplished in part by adding a sentence to the definition of municipal solid waste landfill (MSWLF) unit in 40 CFR 257.2 and 258.2, as follows: “A

<sup>1</sup> EPA published a direct final rule at 66 FR 53535 (Oct. 23, 2001) together with the proposed rule. EPA withdrew the direct final rule after receiving adverse comments. 66 FR 67108 (Dec. 28, 2001). Today’s rule is final action on the proposed rule.

construction and demolition landfill that receives residential lead-based paint waste and does not receive any other household waste is not a MSWLF unit." The Agency explained in the preamble to the proposal that the existing definition of a MSWLF unit includes language which states that a disposal unit "that receives household waste" is a municipal solid waste landfill unit. This language can be construed to prohibit the disposal of any household waste into a facility that is not designed and operated in conformance with 40 CFR part 258 regulations. As a result the Agency proposed to amend the definition of MSWLF unit, to distinguish residential lead-based paint waste, which has been determined to be a household waste, from other types of household waste, for purposes of disposal.

The definition as proposed is as follows: "Municipal solid waste landfill (MSWLF) unit means a discrete area of land or an excavation that receives household waste, and that is not a land application unit, surface impoundment, injection well, or waste pile, as those terms are defined in this section. A MSWLF unit also may continue to receive other types of RCRA Subtitle D wastes, such as commercial solid waste, nonhazardous sludge, and industrial solid waste. Such a landfill may be publicly or privately-owned. A MSWLF unit may be a new MSWLF unit, an existing MSWLF unit or a lateral expansion. A construction and demolition landfill that receives residential lead-based paint waste and does not receive any other household waste is not a MSWLF unit."

The proposed change was designed to simply distinguish residential LBP waste from other household wastes. The proposal would not alter what a MSWLF could or could not receive. MSWLFs would be allowed to continue to receive residential LBP waste as household waste. The proposed rule expressly provided an additional land-based waste disposal option for residential LBP waste.

#### *B. Proposed Definition of "Construction and Demolition Landfill"*

The October 23, 2001 notice also proposed to add a definition of a construction and demolition (C&D) waste landfill, which would expressly allow only C&D landfills, and no other types of land disposal units that meet the criteria of 40 CFR part 257, to receive residential LBP waste. The Agency proposed to define a C&D landfill as follows: "Construction and demolition (C&D) landfill means a solid waste disposal facility subject to the

requirements of subparts A or B of this part that receives construction and demolition waste and does not receive hazardous waste (defined in Sec. 261.3 of this chapter) other than conditionally exempt small quantity generator waste (defined in Sec. 261.5 of this chapter), or industrial solid waste (defined in Sec. 258.2 of this chapter). A C&D landfill typically receives any one or more of the following types of solid wastes: roadwork material, excavated material, demolition waste, construction/renovation waste, and site clearance waste." The proposed rule would add this definition to 40 CFR parts 257 and 258.

#### *C. Proposed Definition of "Residential Lead-Based Paint Waste"*

Finally, EPA proposed to define "residential lead-based paint waste" to clarify the scope of the waste stream addressed by the proposed rule. The proposed definition of residential lead-based paint waste is as follows: "Residential lead-based paint waste means waste generated as a result of lead-based paint activities (including abatement, rehabilitation, renovation and remodeling) in homes and other residences. The term residential lead-based paint waste includes, but is not limited to, lead-based paint debris, chips, dust, and sludges." Not included in the proposed definition of residential LBP waste were residential LBP demolition and deconstruction waste, and LBP waste from nonresidential structures such as public and commercial buildings, warehouses, bridges, water towers, and transmission towers.

In proposing the definition of residential lead-based paint waste, the Agency included these particular LBP activities because they were limited to residences and would pose lead hazards to occupants, especially to children. We included the particular waste types (*i.e.*, debris, chips, dust, and sludges) because they are typically generated during the named LBP activities.

#### *D. Rationale for Proposed Rule*

In the preamble to the proposal, EPA explained the Agency's rationale and justification of the proposed changes, as well as the analytical basis for the proposal. The proposal provided a specific discussion of: (1) The reasons that residential lead-based paint is a concern to children; (2) the Congressional enactment of the Residential Lead-Based Paint Hazard Reduction Act of 1992 (hereinafter referred to as Title X of the Housing and Community Development Act of 1992, or Title X); (3) the concerns of

stakeholders who have seen the application of RCRA's hazardous waste regulations as a barrier to the cost-effective abatement of lead hazards; (4) the 1988 proposed rule under the Toxic Substances Control Act (TSCA) which proposed new TSCA management and disposal standards for LBP debris generated by contractors from pre-1978 homes and public and commercial buildings; (5) the 1988 temporary suspension of the toxicity characteristic for specified lead-based paint debris under RCRA; and (6) the July 31, 2000 memorandum clarifying the regulatory status under RCRA Subtitle C of wastes generated as a result of LBP activities, including abatements, renovation and remodeling, and rehabilitations in homes and other residences. In the July 31, 2000 memorandum, the Agency interpreted residential LBP waste as a household waste excluded from the hazardous waste management requirements pursuant to the household waste exclusion in 40 CFR 261.4(b)(1), thus giving rise to the proposed amendments to parts 257 and 258 to expand disposal options for residential LBP waste to include C&D landfills, as well as MSWLF units.

### **III. Summary of Public Comments and the Agency's Response to Those Comments**

The Agency received a total of eight comments on the proposed residential LBP waste rule: four from construction and/or demolition trade associations, and one each from a state, an association of state agencies, an environmental organization, and an individual. In general, commenters supported the proposal to allow residential LBP waste to be disposed of in C&D landfills. However, some commenters requested clarifications of the rule or preamble language or suggested additions to the rule language.

#### *Definition of Residential Lead-Based Paint Waste*

The state commenter argued that the proposed rule contained a significant flaw by including chips, dust and sludges in the definition of "residential lead-based paint waste," because EPA failed to take into account the potential for sleet, surface-water or wind-borne movement of lead paint chips, dust, and sludges off-site from a C&D landfill. The commenter stated that the placement of LBP dust, chips and sludges in an open environment (*i.e.*, a landfill that does not provide for daily cover) over an extended period of time, *e.g.*, 30 days, may allow a significant rain or wind event to transport lead-containing materials off-site. The commenter

further stated that sudden intense rain events or winds above 20 to 25 miles per hour can transport lead-containing wastes off-site by surface water or air currents. The commenter suggested that requiring daily cover or special packaging at C&D landfills for the above-mentioned wastes would mitigate the potential for adverse impact from surface water or air transport.

Because other features of C&D landfills and LBP waste handling practices serve to mitigate potential impacts from surface water or air transport, the Agency does not believe that requirements for daily cover or special packaging are needed on the federal level. Surface water transport off-site by sudden intense rain events would constitute "non-point source" pollution under the Clean Water Act. To mitigate potential surface water impacts, C&D landfills must comply with 40 CFR 257.3–3(c), which requires that a facility or practice shall not cause non-point source pollution that violates legal requirements implementing an areawide or statewide water quality management plan approved by EPA under the Clean Water Act.

To further mitigate potential water or air transport, both EPA and the U.S. Department of Housing and Urban Development (HUD) have issued guidance for LBP waste management calling for the containment of LBP wastes in plastic with sealed seams. EPA's "Reducing Lead Hazards When Remodeling Your Home" EPA 747-K-97-001 (<http://www.epa.gov/lead/rrpamph.pdf>) and EPA's Model Renovation Training Course EPA 747-B-00-005/6 (<http://www.epa.gov/opptintr/lead/rrmodel.htm>) both call for safe and secure disposal. Safe and secure disposal involves placing the LBP wastes in plastic (4–6 mil poly) bags that are sealed closed. HUD modified the EPA training course and developed their own training program to serve the specific needs of HUD's constituents. The HUD training course entitled "Addressing Lead-Based Paint Hazards During Renovation, Remodeling and Rehabilitation in Federally Owned and Assisted Housing" (also referred to as "The 3R Course") ([http://www.hud.gov/offices/lead/training/3r/3r\\_course.cfm](http://www.hud.gov/offices/lead/training/3r/3r_course.cfm)) was first delivered to remodeling and rehabilitation workers during HUD's nationwide training initiative in 2001–2002. HUD's training recommends that safe disposal of LBP wastes be accomplished by means of plastic bags. Other HUD brochures and documents also recommend that LBP wastes be placed in plastic bags for safe disposal. These brochures include:

"Lead Paint Can Poison: Is Your Family at Risk?" (<http://www.hud.gov/offices/lead/outreach/parents.pdf>).

"Lead Paint Safety—A Field Guide for Painting, Home Maintenance, and Renovation Work" (<http://www.hud.gov/offices/lead/training/LBPguide.pdf>).

"Caution: Lead Paint Handle With Care" (<http://www.hud.gov/offices/lead/outreach/tradesOKAYTOPRINT.pdf>).

"Lead Paint Can Poison: Protect Your Family When You Repaint or Remodel". (<http://www.hud.gov/offices/lead/outreach/remodel.pdf>)

HUD also operates the Lead-Based Paint Hazard Control Grant Program that has as its primary purpose to reduce the exposure of young children to lead-based paint hazards in their homes. The program provides grants to State and local governments for control of lead-based paint hazards in privately owned, low income owner-occupied and rental housing. These grants are designed to stimulate the development of a trained and certified hazard evaluation and control industry. Evaluation and hazard control work under the program must be conducted by either contractors who are certified and workers who are trained through a State-accredited program or by contractors trained in lead-safe work practices in the case of interim controls.

Moreover, as of March 1, 2000, lead service providers within the United States must be certified (or licensed) under an EPA authorized lead program. Most of the States have developed and are administering such a program and EPA certifies lead service providers in states that do not have their own programs. As of January 2003, 38 States had EPA-approved state lead programs that actively certify (license) lead service providers.

EPA has also discussed this issue with the National Association of Demolition Contractors (NADC). NADC re-confirmed EPA's understanding that paint chips and dust are managed in plastic bags. NADC stated that lead-based dust is removed with vacuums with HEPA filters and that the vacuum bags are removed and then tied closed prior to disposal. Paint chips that may fall on a plastic sheet are collected in the plastic sheet which is then placed in a tied plastic bag.

As stated above, the EPA believes that sufficient guidance, literature, training programs, EPA-approved state lead programs, and current practices exist so that whether the LBP waste is in the form of chips, dust, or sludge it will be managed appropriately (*i.e.*, containment in plastic bags on site prior to transport to disposal). At the disposal

facility, the containment plastic serves to mitigate against potential impacts of water or wind transport.

Additionally, where water or wind transport are problematic, States have demonstrated their ability, even in the absence of a federal requirement, to impose additional requirements for weekly, monthly, or daily cover as necessary to control particulate releases. According to the 1995 report, "Construction and Demolition Waste Landfills," 14 States require on-site C&D units to provide daily cover, while 19 States require daily cover at off-site C&D units. Based on these C&D landfill features and LBP waste handling practices, the Agency does not believe it is necessary to impose on the federal level a requirement for daily cover at C&D landfills receiving LBP waste.

Two industry association commenters stated that lead-based paint architectural debris generated from all structures, commercial and industrial, as well as, residential, can safely be disposed of in C&D landfills (*i.e.*, Subtitle D facilities). The commenters disagreed with the Agency's statement in the preamble that demolition and deconstruction waste was not similar to household waste. The commenters believe that LBP material handled by the demolition industry in commercial and industrial structures is no more dangerous to public health and the environment than when LBP appears in a residential structure.

The Agency wishes to clarify that today's rule is an outgrowth of the July 31, 2000 Memorandum stating that waste generated as a result of LBP activities in homes and other residences falls within the exclusion for "household waste" in 40 CFR 261.4(b)(1). (See 66 FR 53569.) The scope of this rulemaking concerns only residential lead-based paint wastes and not lead-based paint wastes from commercial and industrial structures because lead-based paint waste from commercial and industrial structures does not fall within the exclusion for "household waste" in 40 CFR 261.4(b)(1) or the definition of "household waste" in 40 CFR 258.2. Thus, *residential* LBP waste that would otherwise be hazardous waste subject to the hazardous waste management requirements of Subtitle C of RCRA can be managed under Subtitle D of RCRA. The purpose of this rulemaking is to expand Subtitle D disposal options for this particular household waste, which, without today's rule could only be disposed of in municipal solid waste landfills pursuant to 40 CFR part 258.

The July 31, 2000 Memorandum did not affect the regulatory status of

nonresidential LBP waste, such as that generated during the abatement or renovation and remodeling of a commercial building. "Household waste" is defined as "any material (including garbage, trash and sanitary waste in septic tanks) derived from households (including single and multiple residences, hotels and motels, bunkhouses, ranger stations, crew quarters, campgrounds, picnic grounds and day-use recreation areas)." (Emphasis added.)

The Agency recognizes that not all lead-based paint waste, whether from residential, commercial, or industrial sources, is "hazardous waste" which must be managed under RCRA Subtitle C. Any LBP waste that is not hazardous waste can be safely disposed of in a Subtitle D landfill, including a C&D waste landfill.

Several commenters stated that the proposed rule was not sufficiently clear as to the distinctions between those LBP activities that generate waste that would qualify as "residential LBP waste" (e.g. abatement, rehabilitation, renovation, and remodeling") and those that would not fall within the scope of the rule (e.g., "demolition and deconstruction"). One of these commenters stated that the regulated community might believe that there is some deconstruction or demolition occurring whenever you perform rehabilitation, renovation, remodeling, and perhaps to some extent abatement. The commenter suggested that the focus of the final rule be on waste type and not on waste activity.

The Agency distinguishes demolition and deconstruction activities from abatement, rehabilitation, renovation, and remodeling on the basis that demolition and deconstruction result in the elimination of the residential structure, while the residential structure remains where the other listed activities are conducted. The proposed definition of residential lead based paint waste does not include residential demolition and deconstruction activities. The proposed definition was limited to LBP waste that would be subject to Subtitle C of RCRA, except that it is included within the household waste exclusion in 40 CFR 261.4(b)(1). The Agency has applied two criteria to define the scope of the exclusion: (1) The waste must be generated by individuals on the premises of a household, and (2) the waste must be composed primarily of materials found in the wastes generated by consumers in their homes (49 FR 44978 and 63 FR 70241). In the case of LBP wastes, we have determined that demolition and deconstruction, which result in the elimination of the household structure, are outside the

scope of the household waste exclusion and therefore are not included in the definition of "residential LBP waste." Although demolition activities and renovation activities may produce some of the same types of waste, the waste type is not a factor for consideration under 40 CFR 261.4(b)(1), and therefore, today's final rule continues to read as proposed. The Agency wants to make it clear that deconstruction and demolition wastes can continue to be placed in construction and demolition waste landfills provided that these types of wastes do not exhibit the toxicity or any other characteristic (i.e., are not a hazardous waste).

One commenter was specifically concerned that the proposed definition of residential lead-based paint waste could create confusion about the scope of activities that are considered "lead-based paint activities" under the Toxic Substances Control Act (TSCA). The proposed residential LBP definition states that LBP activities include abatement, rehabilitation, renovation, and remodeling. Regulations promulgated under TSCA define "lead-based paint activities" to mean lead inspection, risk assessment, and abatement in the case of target (most pre-1978) housing (see 40 CFR 745.223). Renovation, remodeling, and rehabilitation are not considered lead-based paint activities under Title X. The commenter was concerned that the Agency was trying to change the scope of the TSCA regulation under the proposed RCRA regulation. The commenter suggested that the term lead-based paint activities be deleted and replaced with the phrase "activities that disturb lead-based paint."

The Agency did not intend or propose to change the scope of the TSCA regulation in the October 2001 proposal. However, to eliminate any potential confusion, the Agency has decided to change the definition of residential LBP wastes to eliminate the words "lead-based paint activities." The definition of residential LBP wastes included in today's final rule does not use the term "lead-based paint activities." This definition is as follows: "Residential lead-based paint waste means waste containing lead-based paint, which is generated as a result of activities such as abatement, rehabilitation, renovation and remodeling in homes and other residences. The term residential lead-based paint waste includes, but is not limited to, lead-based paint debris, chips, dust, and sludges."

#### *Definition of Construction and Demolition Waste Landfill*

A trade association commenter objected to the proposed definition of "construction and demolition waste landfill" because the proposed rule would define a C&D waste landfill as one that does not receive "industrial wastes," as defined in section 258.2. The commenter objected because the definition as proposed would preclude a C&D landfill that receives industrial waste in the form of manufacturer's "off-spec," rejected, or damaged construction materials from accepting residential lead-based paint waste. Thus C&D landfills in that state would have to choose between residential LBP waste or off spec., damaged, or rejected construction materials, but not both.

In the proposed definition of construction and demolition waste landfill, the Agency stated that C&D waste landfills were not eligible to receive "industrial solid wastes as defined in 40 CFR 258.2." The definition of "industrial solid waste" in section 258.2 covers "wastes resulting from" particular manufacturing or industrial processes. In defining C&D landfills, the Agency was concerned about C&D waste landfills receiving wastes generated by manufacturing or industrial processes and, as such, wrote the definition to exclude such wastes. In practice, industrial process wastes are typically managed on-site, or in limited cases, sent off-site to private/commercial industrial waste facilities. Industrial process wastes should not be received for disposal at a C&D waste landfill. The commenter was concerned that off-spec construction products (e.g., toilets or shingles) would not be allowed in a C&D waste landfill because of the proposed definition. However, the Agency views "off-spec," rejected, or damaged construction materials as virtually identical in nature to the type of waste that is appropriately received at a C&D waste landfill and are not "industrial solid waste" as defined at 40 CFR 258.2. Because the definition of industrial solid waste does not explicitly include materials that do not meet manufactures' specifications, are damaged or rejected for use, EPA believes that industrial waste in the form of manufacturer's "off-spec," rejected, or damaged construction materials can be appropriately placed in a C&D landfill. In addition, the Agency expects that States would exercise judgment in what is considered industrial wastes. Thus, EPA believes that the definition in today's final rule accommodates disposal of unused construction materials that do not meet

manufacturers' specifications, are damaged or rejected for use.

Another commenter stated that the definition of C&D landfill as proposed could be interpreted to mean that conditionally exempt small quantity generator waste could be accepted in a 40 CFR part 257 Subpart A facility. The commenter suggested a wording change to eliminate this possible misinterpretation.

EPA does not intend that a C&D landfill be allowed to receive conditionally exempt small quantity generator wastes if the C&D landfill meets the requirements of 40 CFR part 257 Subpart A, but does not meet the requirements of part 257, subpart B. Therefore, the Agency has changed the definition of C&D waste landfill to eliminate any potential confusion. The definition has been changed to clarify that conditionally exempt small quantity generator wastes can only be disposed of in a C&D landfill that meets the requirements of 40 CFR part 257, Subpart B.

#### *Effect on State Programs*

The state association commenter indicated that it is important that EPA be explicit that states are not required to amend their programs to incorporate today's rule; however the commenter also suggested language to assure States that their prior approved programs will not be reopened regardless of whether they adopt today's rule or not. EPA agrees with the comment and has revised the language in Section V. of today's preamble to make this clear.

#### *Lead-Contaminated Soils*

Lastly, a commenter stated that EPA had missed a golden opportunity to allow lead-contaminated soils to be managed similarly and requested that EPA move expeditiously to craft a rule to allow lead-contaminated soils to be disposed of in C&D and municipal solid waste landfills. The commenter claimed that the disposal of lead-contaminated soils in C&D landfills and municipal solid waste landfills is environmentally safer than is the disposal of lead-based paint debris. The commenter also argued that the cost of managing those soils that fail the TCLP under the RCRA hazardous waste requirements discourages soil lead abatement from residences. As discussed previously, today's rulemaking is limited to providing the C&D landfill disposal option for residential lead-based paint waste addressed in the July 31, 2000 Memorandum. Lead-contaminated soils were not included in the July 31, 2000 Memorandum, thus EPA is not

addressing disposal of lead-contaminated soils at this time.

#### *Summary of Final Rule Changes*

This final rule will expressly allow residential lead-based paint waste to be disposed of in construction and demolition waste landfills by clearly stating that a construction and demolition landfill accepting residential lead-based paint waste, and no other household waste, is not a municipal solid waste landfill unit. Today's action does not prevent a municipal solid waste landfill from continuing to receive residential lead-based paint waste. Two minor changes were made to the final regulatory language based on comments received on the proposal. Today's final rule was modified to remove "LBP activities" to one that includes "activities that disturb LBP." The definition of construction and demolition waste landfill was changed to eliminate any confusion so that small quantity generator waste can only be disposed of in a facility that meets the requirements of 40 CFR part 257, subpart B.

#### **IV. Other Applicable Federal, State, Tribal, and Local Requirements**

Today's final rule would not alter the authority of State, local and Tribal governments to regulate LBP waste more stringently than does EPA. Generators of residential LBP waste should contact the appropriate State environmental agencies to determine if there are additional or more stringent disposal requirements for residential LBP waste. Also, generators are subject to applicable HUD and/or TSCA regulations when addressing residential LBP hazards.

#### **V. How Will States and Tribes Implement This Final Rule?**

Because today's final rule is less stringent than existing federal criteria, States are not required to amend their permit programs which have been determined to be adequate under 40 CFR part 239. States have the option of amending statutory or regulatory definitions pursuant to today's final rule. If a state chooses to amend its permit program pursuant to today's action, the State would be required to notify the Regional Administrator of the modification as provided by 40 CFR 239.12. Whether a State chooses to incorporate today's rule into its solid waste program has Statutory and Executive Order Reviews no effect on its existing status with respect to EPA approval, *i.e.*, State revisions will not open previously approved solid waste programs for Federal review.

Today's amendments are directly applicable to landfills in States without an approved permit program under part 239 and in Indian Country. We encourage Tribes to adopt today's rule into their programs to promote lead-based paint abatement activities in homes and other residences in Indian Country.

#### **VI. How Does This Final Rule Comply With Applicable Statutes and Executive Orders?**

##### *Statutory and Executive Order Reviews*

##### A. Executive Order 12866: Regulatory Planning and Review

Under Executive Order 12866, EPA must determine whether a regulatory action is significant and therefore subject to Office of Management and Budget (OMB) review and the other provisions of the Executive Order. The Order defines a significant regulatory action as one that is likely to result in a rule that may: (1) Have an annual effect on the economy of \$100 million or more or adversely affect in a material way the economy, a sector of the economy, productivity, competition, jobs, the environment, public health or safety, or State, local, or tribal governments or communities; (2) create a serious inconsistency or otherwise interfere with an action taken or planned by another agency; (3) materially alter the budgetary impact of entitlements, grants, user fees, or loan programs or rights and obligations or recipients thereof; or (4) raise novel legal or policy issues arising out of legal mandates, the President's priorities, or the principles set forth in Executive Order 12866.

It has been determined that this rule is not a "significant regulatory action" under the terms of Executive Order 12866 and is therefore not subject to OMB review.

EPA has performed a full economic analysis, "Economic Analysis of EPA's Final Rule Amending 40 CFR parts 257 and 258," which is available in the docket for today's rule. The Economic Analysis concludes that this rule will impose no additional costs to parties, but may result in cost savings and incremental public health benefits. The rule authorizes the disposal of residential LBP waste in C&D landfills, where previously, as "household waste" under the July 31, 2000 policy memorandum, disposal was authorized only in MSWLFs. Therefore, EPA believes that, in those parts of the country where costs associated with transport to and disposal in C&D landfills is less expensive than costs associated with MSWLF disposal, some

residential LBP waste will be diverted from MSWLFs to C&D landfills. Where this occurs, generators will benefit from lower waste management and disposal costs.

EPA believes that only residential LBP waste generators in the Midwest, Northeast, and South regions will shift disposal from MSWLFs to C&D landfills, based on an analysis of the relative costs of MSWLF and C&D landfill disposal by region. EPA further believes that the percentage of residential LBP waste that is affected is proportional to the share of these three regions in the number of housing units with LBP, which is 84.4 percent. Under these assumptions, an estimated 0.87 million tons of residential LBP waste may be diverted from MSWLFs to C&D landfills annually. This represents 0.73 percent of the total volume of all waste disposed of in MSWLFs annually. This shift in disposal would save residential LBP waste generators in the Midwest, Northeast, and South regions up to an estimated \$16.76 million annually. The savings accruing to generators of residential LBP abatement waste is estimated at \$0.79 million per year, while the savings accruing to generators of residential renovation and remodeling waste is \$15.98 million per year.

EPA estimates that of the \$0.79 million in savings that could accrue to generators of residential LBP abatement waste, an estimated 39.7 percent, or \$0.31 million, will be generated annually in the public housing sector. EPA assumes that in the public sector, any savings in residential LBP waste management and disposal costs will be used to conduct additional LBP abatements. Given an average cost for LBP abatement in public housing units of \$3,650, the \$0.31 million in annual savings would fund an additional 86 abatements each year. This ensuing increase in LBP abatement projects would result in a more rapid reduction in the potential for exposure to the hazards of LBP, especially for children. These hazards include decreased intelligence (*i.e.*, lower IQ), behavioral problems, reduced physical stature and growth, and impaired hearing.

#### B. Paperwork Reduction Act

The Office of Management and Budget (OMB) has approved the information collection requirements contained in this rule under the provisions of the Paperwork Reduction Act, 44 U.S.C. 3501 *et seq.* and has assigned OMB control number 2050-0154. Copies of the ICR document(s) may be obtained from Susan Auby, by mail at the Office of Environmental Information,

Collection Strategies Division, U.S. Environmental Protection Agency (2822), 1200 Pennsylvania Ave., NW., Washington, DC 20460, by email at [auby.susan@epa.gov](mailto:auby.susan@epa.gov), or by calling (202) 260-2740. A copy may also be downloaded off the Internet at <http://www.epa.gov/icr>.

Today's action does not impose any new information collection burden. The previously approved information collection requirements are contained in the existing regulations at 40 CFR 257.30. Burden means the total time, effort, or financial resources expended by persons to generate, maintain, retain, or disclose or provide information to or for a Federal agency. This includes the time needed to review instructions; develop, acquire, install, and utilize technology and systems for the purposes of collecting, validating, and verifying information, processing and maintaining information, and disclosing and providing information; adjust the existing ways to comply with any previously applicable instructions and requirements; train personnel to be able to respond to a collection of information; search data sources; complete and review the collection of information; and transmit or otherwise disclose the information.

An Agency may not conduct or sponsor, and a person is not required to respond to a collection of information, unless it displays a currently valid OMB control number. The OMB control numbers for EPA's regulations are listed in 40 CFR part 9 and 48 CFR Chapter 15.

#### C. Regulatory Flexibility Act

The Regulatory Flexibility Act (RFA), as amended by the Small Business Regulatory Enforcement Fairness Act of 1996 (SBREFA), 5 U.S.C. 601 *et seq.*, generally requires an agency to prepare a regulatory flexibility analysis of any rule subject to notice and comment rulemaking requirements under the Administrative Procedure Act or any other statute, unless the agency certifies that the rule will not have a significant economic impact on a substantial number of small entities. Small entities include small businesses, small organizations, and small governmental jurisdictions.

For purposes of assessing the impacts of today's final rule on small entities, a small entity is defined as: (1) A small business that is primarily engaged in lead paint removal as described in the North American Industry Classification System (see <http://www.sba.gov/size/SIC2NAICSmain.html>); (2) a small governmental jurisdiction that is a government of a city, county, town,

school district or special district with a population of less than 50,000; and (3) a small organization that is any not-for-profit enterprise which is independently owned and operated and is not dominant in its field.

After considering the economic impacts of today's final rule on small entities, I certify that this action will not have a significant economic impact on a substantial number of small entities. This final rule does not impose any new requirements on small entities. In fact, the rule will provide an additional non-mandatory option for the disposal of residential LBP waste, which could result in less cost in managing residential LBP waste.

#### D. Unfunded Mandates Reform Act

Title II of the Unfunded Mandates Reform Act of 1995 (UMRA), Public Law 104-4, establishes requirements for Federal agencies to assess the effects of regulatory actions on State, local, and Tribal governments, and the private sector. Under Section 202 of the UMRA, EPA generally must prepare a written statement, including a cost-benefit analysis, for proposed and final rules with "Federal mandates" that may result in expenditures to State, local, and tribal governments, in the aggregate, or to the private sector, of \$100 million or more in any one year. Before promulgating an EPA rule for which a written statement is needed, Section 205 of the UMRA generally requires EPA to identify and consider a reasonable number of alternatives and adopt the least costly, most cost effective or least burdensome alternative that achieves the objective of the rule. The provisions of Section 205 do not apply when they are inconsistent with applicable law. Moreover, Section 205 allows EPA to adopt an alternative other than the least costly, most cost-effective or least burdensome alternative if the Administrator publishes with the final rule an explanation why that alternative was not adopted. Before EPA establishes any regulatory requirements that may significantly or uniquely affect small governments, including tribal governments, it must have developed under Section 203 of the UMRA a small government agency plan. The plan must provide for notifying potentially affected small governments, enabling officials of affected small governments to have meaningful and timely input in the development of EPA regulatory proposals with significant Federal intergovernmental mandates, and informing, educating, and advising small governments on compliance with the regulatory requirements.

Today's final rule contains no Federal mandates (under the regulatory provisions of Title II of the UMRA) for State, local, or tribal governments or the private sector. This final rule does not impose any enforceable duty on any State, local or tribal governments or the private sector. Thus, today's final rule is not subject to the requirements of sections 202 and 205 of UMRA.

#### E. Executive Order 13132: Federalism

Executive Order 13132, entitled "Federalism" (64 FR 43255, August 10, 1999), requires EPA to develop an accountable process to ensure "meaningful and timely input by State and local officials in the development of regulatory policies that have federalism implications." Policies that have federalism implications' is defined in the Executive Order to include regulations that have "substantial direct effects on the States, on the relationship between the national government and the States, or on the distribution of power and responsibilities among the various levels of government."

This final rule does not have federalism implications. It will not have substantial direct effects on the States, on the relationship between the national government and the States, or on the distribution of power and responsibilities among the various levels of government, as specified in Executive Order 13132. As explained in Section V. of this preamble, none of today's proposed revisions are more stringent or broaden the scope of the existing Federal requirements. Therefore, States are not required to adopt the revision to the definition of MSWLF unit nor the additional definitions of construction and demolition (C&D) landfill and residential lead-based paint waste in today's rule. Thus, Executive Order 13132 does not apply to this final rule.

#### F. Executive Order 13175: Consultation and Coordination With Indian Tribal Governments

Executive Order 13175, entitled "Consultation and Coordination with Indian Tribal Governments" (65 FR 67249, November 6, 2000), requires EPA to develop an accountable process to ensure "meaningful and timely input by tribal officials in the development of regulatory policies that have tribal implications." This final rule does not have tribal implications as specified in Executive Order 13175. It will not have substantial direct effects on tribal governments, on the relationship between the Federal government and Indian tribes, or on the distribution of power and responsibilities between the

Federal government and Indian tribes, as specified in Executive Order 13175. Today's final rule would expressly provide an additional option for disposal of certain waste applicable in Indian Country, but would not create any mandate on Indian tribal governments. Thus, Executive Order 13175 does not apply to this rule.

#### G. Executive Order 13045: Protection of Children From Environmental Risks and Safety Risks

Executive Order 13045, "Protection of Children from Environmental Health Risks and Safety Risks" applies to any rule that: (1) Is determined to be "economically significant" as defined under Executive Order 12866, and (2) concerns an environmental health or safety risk that EPA has reason to believe may have a disproportionate effect on children. If the regulatory action meets both criteria, the Agency must evaluate the environmental health or safety effects of the planned rule on children, and explain why the planned regulation is preferable to other potentially effective and reasonably feasible alternatives considered by the Agency.

This final rule is not subject to Executive Order 13045 because it is not an economically significant rule as defined by Executive Order 12866. However, this rule will affect decisions involving the environmental health or safety risks to children. In fact, it will benefit children by allowing environmentally protective disposal of residential lead-based paint waste in C&D landfills, which is less costly than disposal in MSWLFs in certain areas of the U.S., therefore reducing the cost of lead abatements. Reducing the cost of LBP abatements will also reduce the amount of time needed to complete abatements in public housing. Lower abatement costs may increase the amount of private homes undergoing abatements. By reducing costs associated with the disposal of LBP waste, the Agency believes that the number of abatements may marginally increase, thus resulting in a reduction of the number of children exposed to LBP.

#### H. Executive Order 13211: Actions That Significantly Affect Energy Supply, Distribution, or Use

This proposed rule is not a "significant energy action" as defined in Executive Order 13211, "Actions Concerning Regulations That Significantly Affect Energy Supply, Distribution, or Use" (66 FR 28355 (May 22, 2001)) because it will not have a significant adverse effect on the supply, distribution, or use of energy.

#### I. National Technology Transfer and Advancement Act of 1995

Section 12(d) of the National Technology Transfer and Advancement Act of 1995 (NTTAA), Pub L. 104-113, Sec. 12(d) (15 U.S.C. 272 note) directs us to use voluntary consensus standards in our regulatory activities unless to do so would be inconsistent with applicable law or otherwise impractical. Voluntary consensus standards are technical standards (for example, materials specifications, test methods, sampling procedures, and business practices) that are developed or adopted by voluntary consensus standards bodies. The NTTAA directs EPA to provide Congress, through OMB, explanations when we decide not to use available and applicable voluntary consensus standards. Today's final rule does not involve technical standards, voluntary or otherwise. Therefore, the NTTAA does not apply to today's final rule.

#### J. Executive Order 12898: Federal Action To Address Justice in Minority Populations and Low-Income Populations

Under Executive Order 12898, "Federal Actions to Address Environmental Justice in Minority Populations and Low-Income Populations," as well as through EPA's April 1995, "Environmental Justice Strategy, OSWER Environmental Justice Task Force Action Agenda Report," and the National Environmental Justice Advisory Council, EPA has undertaken to incorporate environmental justice into its policies and programs. EPA is committed to addressing environmental justice concerns, and is assuming a leadership role in environmental justice initiatives to enhance environmental quality for all residents of the United States. The Agency's goals are to ensure that no segment of the population, regardless of race, color, national origin, or income, bears disproportionately high and adverse human health and environmental effects as a result of EPA's policies, programs, and activities.

Today's final rule is not expected to negatively impact any community, and therefore is not expected to cause any disproportionately high and adverse impacts to minority or low-income communities versus non-minority or affluent communities. On the contrary, since the rule will reduce the cost of performing LBP abatements in certain regions of the U.S., EPA believes that the savings will afford public housing authorities, in particular, the opportunity to conduct additional abatements of LBP hazards in affected

housing units. Tenants of public housing units are possibly more likely to be minority and lower-income households, and the rule should have the effect of providing a differential benefit to such populations.

**K. Congressional Review Act**

The Congressional review Act, 5 U.S.C. 801 *et seq.*, as added by the Small Business Regulatory Enforcement Fairness Act of 1996, generally provides that, before a rule may take effect, the agency promulgating the rule must submit a rule report, which includes a copy of the rule, to each House of the Congress and to the Comptroller General of the United States. EPA will submit a report containing this rule and other required information to the U.S. Senate, the U.S. House of Representatives, and the Comptroller General of the United States prior to publication of the rule in the **Federal Register**. A major rule cannot take effect until 60 days after it is published in the **Federal Register**. This action is not a "major rule" as defined by 5 U.S.C., 804(2). This rule will be effective on June 18, 2003.

**List of Subjects**

*40 CFR Part 257*

Environmental protection, Waste treatment and disposal.

*40 CFR Part 258*

Environmental protection, Reporting and recordkeeping requirements, Waste treatment and disposal, Water pollution control.

Dated: June 12, 2003.

**Christine Todd Whitman,**  
*Administrator.*

■ For reasons set out in the preamble, title 40, chapter I of the Code of Federal Regulations is amended as follows:

**PART 257—[AMENDED]**

■ 1. The authority citation for part 257 is revised to read as follows:

**Authority:** 42 U.S.C. 6907(a)(3), 6912(a)(1), 6944(a), and 6949a(c); 33 U.S.C. 1345(d) and (e).

■ 2. Section 257.2 is amended:

■ a. By adding in alphabetical order the definitions for "Construction and demolition (C&D) landfill" and "Residential lead-based paint waste," and

■ b. By revising the definition of "Municipal solid waste landfill (MSWLF) unit."

The revision and additions read as follows:

**§ 257.2 Definitions.**

\* \* \* \* \*

*Construction and demolition (C&D) landfill* means a solid waste disposal facility subject to the requirements of subparts A or B of this part that receives construction and demolition waste and does not receive hazardous waste (defined in § 261.3 of this chapter) or industrial solid waste (defined in § 258.2 of this chapter). Only a C&D landfill that meets the requirements of subpart B of this part may receive conditionally exempt small quantity generator waste (defined in § 261.5 of this chapter). A C&D landfill typically receives any one or more of the following types of solid wastes: roadwork material, excavated material, demolition waste, construction/renovation waste, and site clearance waste.

\* \* \* \* \*

*Municipal solid waste landfill (MSWLF) unit* means a discrete area of land or an excavation that receives household waste, and that is not a land application unit, surface impoundment, injection well, or waste pile, as those terms are defined in this section. A MSWLF unit also may receive other types of RCRA Subtitle D wastes, such as commercial solid waste, nonhazardous sludge, and industrial solid waste. Such a landfill may be publicly or privately owned. A MSWLF unit may be a new MSWLF unit, an existing MSWLF unit or a lateral expansion. A construction and demolition landfill that receives residential lead-based paint waste and does not receive any other household waste is not a MSWLF unit.

\* \* \* \* \*

*Residential lead-based paint waste* means waste containing lead-based paint, which is generated as a result of activities such as abatement, rehabilitation, renovation and remodeling in homes and other residences. The term residential lead-based paint waste includes, but is not limited to, lead-based paint debris, chips, dust, and sludges.

\* \* \* \* \*

**PART 258—[AMENDED]**

■ 1. The authority citation for part 258 continues to read as follows:

**Authority:** 33 U.S.C. 1345(d) and (e); 42 U.S.C. 6902(a), 6907, 6912(a), 6944, 6945(c) and 6949a(c).

■ 2. Section 258.2 is amended:

■ a. By adding in alphabetical order the definitions for "Construction and demolition (C&D) landfill" and "Residential lead-based paint waste," and

■ b. By revising the definition of "Municipal solid waste landfill (MSWLF) unit."

The revision and additions read as follows:

**§ 258.2 Definitions.**

\* \* \* \* \*

*Construction and demolition (C&D) landfill* means a solid waste disposal facility subject to the requirements in part 257, subparts A or B of this chapter that receives construction and demolition waste and does not receive hazardous waste (defined in § 261.3 of this chapter) or industrial solid waste (defined in § 258.2 of this chapter). Only a C&D landfill that meets the requirements of 40 CFR part 257, subpart B may receive conditionally exempt small quantity generator waste (defined in § 261.5 of this chapter). A C&D landfill typically receives any one or more of the following types of solid wastes: roadwork material, excavated material, demolition waste, construction/renovation waste, and site clearance waste.

\* \* \* \* \*

*Municipal solid waste landfill (MSWLF) unit* means a discrete area of land or an excavation that receives household waste, and that is not a land application unit, surface impoundment, injection well, or waste pile, as those terms are defined under § 257.2 of this chapter. A MSWLF unit also may receive other types of RCRA Subtitle D wastes, such as commercial solid waste, nonhazardous sludge, conditionally exempt small quantity generator waste and industrial solid waste. Such a landfill may be publicly or privately owned. A MSWLF unit may be a new MSWLF unit, an existing MSWLF unit or a lateral expansion. A construction and demolition landfill that receives residential lead-based paint waste and does not receive any other household waste is not a MSWLF unit.

\* \* \* \* \*

*Residential lead-based paint waste* means waste containing lead-based paint, which is generated as a result of activities such as abatement, rehabilitation, renovation and remodeling in homes and other residences. The term residential lead-based paint waste includes, but is not limited to, lead-based paint debris, chips, dust, and sludges.

\* \* \* \* \*

[FR Doc. 03-15363 Filed 6-17-03; 8:45 am]

**BILLING CODE 6560-50-P**

Pursuant to the State of Tennessee's policy of non-discrimination, the Tennessee Department of Environment and Conservation is an Equal Employment Opportunity/Affirmative Action (EEO/AA) employer committed to maintaining a nondiscriminatory, diverse work environment. The department does not unlawfully discriminate on the basis of race, color, religion, sex, national origin, age, disability, veteran status, or on any other basis prohibited by applicable law in any of its programs, services or activities.

Equal Employment Opportunity/Affirmative Action inquiries or complaints may be directed to the EEO/AA Coordinator, Office of General Counsel, William R. Snodgrass Tennessee Tower, 312 Rosa L. Parks Avenue, 2nd Floor, Nashville, TN 37243, 615-532-0131. ADA/AA inquiries or complaints should be directed to the ADA/AA Coordinator, Human Resources Division, William R. Snodgrass Tennessee Tower, 312 Rosa L. Parks Avenue, 22nd Floor, Nashville, TN 37243, 615-532-0207. Hearing impaired callers may use the Tennessee Relay Service (1-800-848-0298)

To reach your local  
ENVIRONMENTAL ASSISTANCE CENTER  
Call 1-888-891-TDEC OR 1-888-891-8332